

2021 – 2022

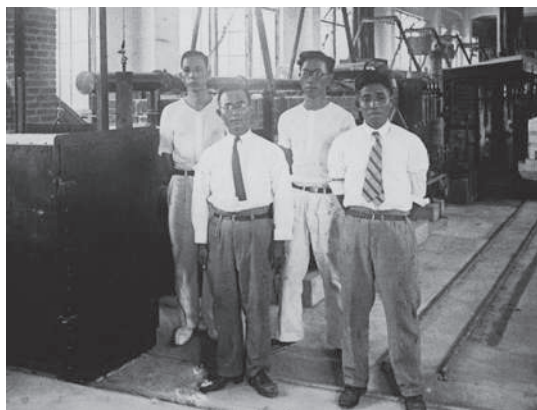

IGNITION
PARTS

IGNITION & SENSOR SPECIALIST



Founded in 1936, the NGK SPARK PLUG Corporate Group, known around the globe as a leading manufacturer of spark plugs, has always developed ceramics as its core competence. Over the years, the company has established a track record of successfully applying the expertise gained in the field of ceramics to other areas to create new value.

Today, NGK SPARK PLUG is a leading manufacturer of ignition parts and vehicle electronics both for OEMs (Original Equipment Manufacturers) and the IAM (Independent Aftermarket) with over 80 years of experience. A total of 41 subsidiaries, 29 production plants, 4 Technical Centers and 14,500 employees around the world ensure optimum processes and a great wealth of knowledge.

The world leader in spark plugs and oxygen sensors, NGK SPARK PLUG has built a strong reputation for quality, reliability and a commitment to excellence. Now as then, the ignition and sensor specialist is dedicated to providing customers with world-class products and services.

In order to react more quickly to the global and regional changes of the market and the NGK SPARK PLUG environment, the company has switched from a central to a regional company management model. As a result, NGK SPARK PLUG EUROPE GmbH, based in Ratingen, Germany, became the EMEA Regional Headquarter in 2017 and has extended its responsibility from only Europe to include Middle East and Africa. Today, the EMEA markets are key to NGK SPARK PLUG's success, making up 25 percent of NGK SPARK PLUG's total global sales.



1979

Foundation of
NGK SPARK PLUG
Deutschland GmbH



1989

NGK SPARK PLUG
Deutschland
becomes NGK SPARK
PLUG EUROPE



Launch of the
sensor brand NTK

1982

Production plant in
Orléans (FR) and Technical
Center in Ratingen (DE)
start operation



Launch of V-Line,
the most successful
spark plug assortment

1991

1997



First lambda sensor for
the Aftermarket available



Launch of NGK ignition
coils for the Aftermarket

2012

2014



Introduction of NTK
exhaust gas temperature
sensors



Acquisition of Wells,
a leading producer of
ignition coils and
sensors in the U.S.

2015

2016



Launch of NTK MAP/MAF
sensors for the Aftermarket

NGK SPARK PLUG EUROPE
takes over responsibility for
the EMEA region

Opening of the new Regional
Distribution Center in
Duisburg, Germany

2017

2018



Launch of NTK engine
speed & position sensors
for the Aftermarket

MANUFACTURERS

SPARK PLUGS

A		H		R	
ABARTH	166	HOMMEL	251	RAM	358
ACURA	166	HONDA	251	RENAULT	359
ALFA ROMEO	166	HUMMER-AM GENERAL	258	ROLLS ROYCE	373
ALPINA	170	HYUNDAI	258	ROVER	373
ARO	171	I		S	
ASIA MOTORS	171	INFINITI	267	SAAB	375
ASTON MARTIN	171	INNOCENTI	269	SEAT	378
AUDI	172	ISUZU	270	SKODA	387
AUSTIN	184	J		SMART	393
AUTOBIANCHI	184	JAGUAR	270	SSANGYONG	393
AZLK (MOSKWITCZ)	184	JEEP	272	STEYR	394
B		K		SUBARU	394
BENTLEY	184	KIA	274	SUZUKI	398
BMW	184	L		T	
BUICK	202	LADA (AVTOVAZ)	280	TALBOT	403
C		LAMBORGHINI	282	TATRA	403
CADILLAC	202	LANCIA	283	TAXI	403
CATERHAM	203	LAND ROVER	286	TOFAS	403
CHEVROLET	203	LEXUS	288	TOFAS / FIAT	404
CHRYSLER	206	LOTUS	290	TOYOTA	404
CITROËN	207	M		V	
D		MASERATI	291	VAZ-GM	417
DACIA	218	MAYBACH	292	VOLKSWAGEN	417
DAEWOO	221	MAZDA	292	VOLVO	438
DAIHATSU	223	MERCEDES	298	W	
DAIMLER	224	MINI	311	WIESMANN	448
DODGE	225	MITSUBISHI	313	Y	
F		MORGAN	323	YUGO	448
FERRARI	227	N		Z	
FIAT	228	NISSAN	323	Z.A.Z.	448
FORD	240	O		ZASTAVA	448
FORD (USA)	249	OPEL	336	P	
FSO	250	P		PEUGEOT	345
G		PORSCHE	356	R	
GAZ (VOLGA)	250	R		RAM	358



MANUFACTURERS

GLOW PLUGS

A

ALFA ROMEO	452
ALPINA	454
ASIA MOTORS	454
AUDI	454
AUSTIN	460
AVIA	460

B

BMW	461
-----	-----

C

CHEVROLET	463
CHRYSLER	463
CITROËN	464

D

DACIA	471
DAEWOO	472
DAF	472
DAIHATSU	473
DODGE	473

F

FIAT	473
FORD	480
FORD (USA)	487
FSO	488

H

HONDA	488
HYUNDAI	488

I

INFINITI	491
INNOCENTI	491
ISUZU	491
IVECO	491

J

JAGUAR	491
JEEP	491

K

KIA	492
-----	-----

L

LADA (AVTOVAZ)	494
LANCIA	494
LAND ROVER	496
LEXUS	497

M

MAHINDRA	497
MAZDA	497
MERCEDES	499
MINI	510
MITSUBISHI	511

N

NISSAN	514
--------	-----

O

OPEL	518
------	-----

P

PEUGEOT	524
PORSCHE	533

R

RENAULT	533
ROVER	557

S

SAAB	558
SEAT	558
SKODA	562
SMART	564
SSANGYONG	565
STEYR	565
SUBARU	566
SUZUKI	566

T

TALBOT	567
TOYOTA	567

U

UAZ	571
-----	-----

V





















VOLKSWAGEN	571
VOLVO	585



IGNITION
PARTS



VEHICLE
ELECTRONICS

 	2 – 27
	28 – 53
  	54 – 79
Ranges overview 	80 – 105
D-POWER ^{NGK}	106 – 107
VLINE	108 – 109
LPG LaserLine	110
IRIDIUM _{IX}	111 – 112
 Racing	113 – 124
 Series	125 – 138
 Series	139 – 164
  	165 – 450
  	451 – 590
  Cross Reference Guide Original Equipment → NGK	591 – 630
  Cross Reference Guide Industry → NGK	631 – 690
Discontinued Products	691 – 697
Disclaimer	698 – 704

How to read our part number: Spark Plugs

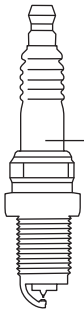

Unit : mm

B		P		R		5		E		S		-11				
Thread size	Hex size	Structure		Resistor		Heat rating		Thread length		Design features		Spark gap				
A	∅ 18.0	Hex 25.4	P	Projected insulator type	R	Resistor	2		E	19.0	B	Integral terminal (CR8EB)	None	Motorcycle : 0.7-0.8		
B	∅ 14.0	Hex 20.8	M	Small spark plug	Z	Inductive resistor type	4		EF	17.5	CM	Slant ground electrode Compact type (Exposed insulator length: 18.5)		-8	Car : 0.8-0.9	
BC	∅ 14.0	Hex 16.0					6		H	12.7			CS		Slant ground electrode	
BK	∅ 14.0	Hex 16.0	U	Surface gap, Semi-surface discharge gap or Supplementary gap			7		L	11.2	G,GV	Racing spark plug	-9	0.9		
C	∅ 10.0	Hex 16.0					8		I	Iridium central electrode				-10	1.0	
D	∅ 12.0	Hex 18.0					9								IX	Iridium IX spark plug
DC	∅ 12.0	Hex 16.0					10		J	2-projecting-ground electrodes				-13		
E	∅ 8.0	Hex 13.0					K								2-ground-electrodes	-15
* Exception B(P)M-A.Y : ∅ 14.0, Hex 19.0 P(P)-(E)F : ∅ 14.0, Hex 16.0 CM-6 : ∅ 10.0, Hex 14.0		BC : Old JIS standard size The length from gasket circuit to terminal contact is 53.0mm.		BK : ISO / JIS standard size The length from gasket circuit to terminal contact is 50.5mm.		Tapered seat type A(P)-F : 10.9 B(P)-F : 11.2 BM(P)-F : 7.8			Small type plug B(P)M- : 9.5 B-LM : 9.5 CM- : 9.5 CM-6 : 8.6 C-50 : 8.5		-LM		Compact type (Insulator length: 14.5)	-S		
											N		Special ground electrode	-E		Special resistance
										P		Platinum spark plug Single ground electrode : Double platinum	IX-P		Iridium MAX plug	
												Multi-ground electrode : Single platinum in central electrode	LPG 1-8		LaserLine spark plug range for gas engine use	
										Q		4-ground-electrodes				
										S		Standard type				
										T		3-ground-electrodes				
										U		Semi-surface discharge gap				
										Y		V-grooved center electrode				
										Z		Special design				

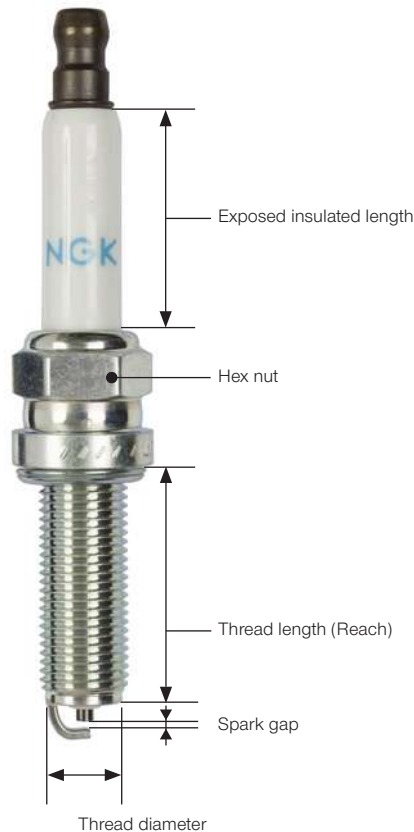

How to read our part number: Spark Plugs



P F R 5 A - 11

Unit : mm

P		F					R		5		A		-11		
Plug type		Thread diameter	Thread length	Seat configuration	Hex size	Resistor		Heat rating		Design		Spark gap			
DI	High ignitability plug: Double fine electrodes	F	ø 14.0	19.0	Gasket	Hex 16.0	R	Resistor	2		A,B,C... Suffix code		None	Motorcycle : 0.7-0.8	
		FE	ø 14.0	19.0	Gasket	Hex 16.0			4		Car : 0.8-0.9				
I	Central electrode: Iridium Ground electrode: Platinum	G	ø 14.0	19.0	Gasket	Hex 20.8	5	-7	0.7						
		J	ø 12.0	19.0	Gasket	Hex 18.0	6		-9		0.9				
L	Long thread reach plug	K	ø 12.0	19.0	Gasket	Hex 16.0	7	I	Iridium central electrode		-10	1.0			
P	Double platinum spark plug	KA	ø 12.0	19.0	Gasket	Hex 14.0	8				-11	1.1			
S	High ignitability plug : thin square tip type	KB	ø 12.0	19.0	Gasket	Bi-Hex 14.0 (Bi-hexagonal *)	9	IX	Iridium IX spark plug		-13	1.3			
Z	Projected firing end	KE	ø 12.0	19.0	Gasket	Hex 16.0	10				P	Platinum central electrode	-15	1.5	
Above alphabets are occasionally used in combination <Example>ILFR..., PLZFR..., When „L“ is included, priority is given to „L“ (long reach)* in thread length. <Example> *Gasket type FR5AP : Thread length 19.0mm ↓ LFR5AP-11 : Thread length 26.5mm *Tapered seat type PTR5C-13 : Thread length 17.5mm ↓ PLTR6A-10G : Thread length 25.0mm		KF	ø 12.0	19.0	Gasket	Hex 14.0	*Exception TR5A-10, TR5A-13, TR5B-13, TR6B-10, TR6B-13, PTR5A-10, PTR5A-13 : Thread length 25.0mm *Bi-hexagonal socket is necessary. *FE, KE, KF, KG, MF : Longer exposed insulator length type		Bi-hexagonal Hexagonal 		**When there is „I“ or „P“ at the beginning of part number („I“ or „P“ after heat rating becomes suffix code.) <Example> IZFR6P8 is Iridium spark plug I : Iridium P : Suffix code * <Exception> ZFR6P-G is nickel spark plug		-A	Non gasket	
		KG	ø 12.0	19.0	Gasket	Bi-Hex 14.0 (Bi-hexagonal *)							-D	Metal shell : nickel plating	
		L	ø 10.0	12.7	Gasket	Hex 16.0							-E	Special resistance	
		M	ø 10.0	19.0	Gasket	Hex 16.0							-G	Copper cored ground electrode	
		MA	ø 10.0	19.0	Gasket	Hex 14.0							-H	Special thread shape	
		MF	ø 10.0	19.0	Gasket	Hex 14.0							-J	2 ground-electrode	
		NA	ø 12.0	17.5	Tapered seat	Hex 14.0							-K	Vibration-resistance ground electrode	
		T	ø 14.0	17.5	Tapered seat	Hex 16.0							-N	Special ground electrode	
		U	ø 14.0	11.2	Tapered seat	Hex 16.0							-Q	4-ground-electrode	
		W	ø 18.0	10.9	Tapered seat	Hex 20.8							-S	Special gasket	
X	ø 14.0	9.5	Gasket	Hex 20.8	-T	3-ground-electrode									
Y	ø 14.0	11.2	Tapered seat	Hex 16.0	-U	Semi-surface discharge type									
						IX-P	Iridium MAX plug								
						LPG 1-8	LaserLine spark plugs range for gas engines								

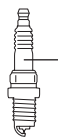

RE 7 C L

RE		7		C		-L	
Plug type		Heat rating		Design		Spark gap	
RE	Plug for rotary engines	5		A,B,C...Suffix code		-L	Leading side
SD	Plug for rotary engines (Semi-surface discharge gap)	6		-T		Trading side	
		7					
		8					
		9					
		10					
		11	Cold type				

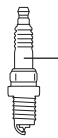

HB 6 A IX - 11 P

HB		6		A				IX		-11		P	
Plug type		Heat rating		Thread diameter	Thread length	Seat configuration	Hex size			Spark gap			
HB	HYBD (3-ground-electrode hybrid type)	4		A	ø 14.0	20.5	Gasket	Hex 16.0	IX	-8	0.8		
		5		B	ø 14.0	19.0	Gasket	Hex 16.0					
		6		-9	1.0								
		7				-11	1.1						
8	Cold type	-13	1.3										

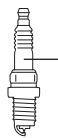

DF 6 H A - 11 A

DF		6		H				-11		A				
Plug type		Heat rating		Thread diameter	Thread length	Seat configuration	Hex size	Spark gap						
DF	High ignitability plug (Double fine electrodes)	4		A	ø 14.0	19.0	Gasket	Hex 16.0	-8	0.8	A,B,C... Suffix code			
		5		B	ø 14.0	26.5	Gasket	Hex 16.0						
DFH	High ignitability plug (DF + Hybrid type)	6		-10	C	ø 12.0	26.5	Gasket	Hex 14.0	1.0				
		7									-11	1.1		
		8											-13	1.3
		9												
				*DF6H-11A : Thread length 28.0mm										



So lesen Sie unsere Teilenummer: Zündkerzen

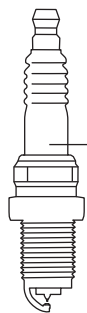

B P R 5 E S - 11

Einheit: mm

B		P		R		5		E		S		-11	
Gewindedurchmesser	Sechskant	Struktur	Entstörwiderstand	Wärmewert	Gewindelänge	Konstruktionsmerkmale		Elektrodenabstand					
A	∅ 18,0	Hex 25,4	P vorgeschobene Isolatorspitze	R Widerstand	2	<p>warme Type</p> <p>kalte Type</p>	E 19,0	B feste SAE-Anschlussmutter (CR8EB)	leer	Motorrad : 0,7-0,8			
B	∅ 14,0	Hex 20,8	Z induktiver Widerstand	4	EF 17,5		CM Schräge Masseelektrode Kompaktbauart (Freiliegende Isolatorlänge: 18,5)	leer	Auto : 0,8-0,9				
BC	∅ 14,0	Hex 16,0	M Kompaktkerze	5	EH 19,0 zur Hälfte ausgeführt								
BK	∅ 14,0	Hex 16,0	U Gleitfunkentyp oder Zusatzfunkenstrecke	6	H 12,7		CS Schräge Masseelektrode	-8	0,8				
C	∅ 10,0	Hex 16,0		7	L 11,2		G,GV Rennzündkerze	-9	0,9				
D	∅ 12,0	Hex 18,0	leer	8	Kegeldichtsitz A(P)-F : 10,9 B(P)-F : 11,2 BM(P)-F : 7,8		I Mittelelektrode, Iridium	-10	1,0				
DC	∅ 12,0	Hex 16,0		9			leer	IX Iridium-Zündkerze	-11	1,1			
E	∅ 8,0	Hex 13,0	* Ausnahme B(P)M-A,Y : ∅ 14,0, Hex 19,0 R(P)-(E)F : ∅ 14,0, Hex 16,0 CM-6 : ∅ 10,0, Hex 14,0	10	Zündkerze, klein B(P)M- : 9,5 B-LM : 9,5 CM- : 9,5 CM-6 : 8,6 C-50 : 8,5		J 2 überstehende Masseelektroden	-13	1,3				
BC : Alte JIS-Standardgröße Die Länge zwischen dem Dichtungsring und der Anschlussklemme beträgt 53,0 mm.		BK : ISO-/JIS-Standardgröße Die Länge zwischen dem Dichtungsring und der Anschlussklemme beträgt 50,5 mm.					K 2 Masseelektroden	-15	1,5				
							-LM Kompakt-Type (Isolatorlänge: 14,5)	-S	spezieller Dichtring				
						N spezielle Masse-Elektrode	-E	spezieller Widerstand					
						P Platinelektrode Einzel-Masseelektrode: Mehrfach-Masseelektrode Doppelplatin: Einzelplatin in Mittelelektrode	IX-P	Iridium MAX Kerze					
						Q 4 Masseelektroden	LPG 1-8	LaserLine-Zündkerzenserie für gasbetriebene Motoren					
						S Standard Type							
						T 3 Masseelektroden							
						U Halbleitfunkentyp							
						Y Mittelelektrode mit V-Einkerbung							
						Z spezielle Konstruktion							



So lesen Sie unsere Teilenummer: Zündkerzen

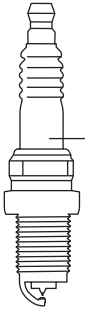

P F R 5 A - 11

Einheit: mm

P		F				R		5		A		-11			
Zündkerzentyp		Gewinde-durchmesser	Gewinde-länge	Sitz-konstruktion	Sechskant	Entstörwiderstand		Wärmewert		Konstruktion		Elektrodenabstand			
DI	besonders hohe Zündfähigkeit, doppelt ausgeführte, feine Elektroden	F	∅ 14,0	19,0	Dichtring	Hex 16,0	R	Widerstand	2		A,B,C... Suffix code		leer	Motorrad : 0,7-0,8 Auto : 0,8-0,9	
I	Mittlelektrode: Iridium Masselektrode: Platin	FE	∅ 14,0	19,0	Dichtring	Hex 16,0			4					-7	0,7
L	besonders langes Gewinde	G	∅ 14,0	19,0	Dichtring	Hex 20,8			5					-9	0,9
P	Zündkerze, Doppelplatin	J	∅ 12,0	19,0	Dichtring	Hex 18,0			6					-10	1,0
S	Zündkerze mit hoher Zündwilligkeit: dünn, mit quadratischer Spitze	K	∅ 12,0	19,0	Dichtring	Hex 16,0			7			I	Mittlelektrode, Iridium	-11	1,1
Z	Vorgezogene Funkenlage	KA	∅ 12,0	19,0	Dichtring	Hex 14,0			8			IX	Iridium-Zündkerze	-13	1,3
		KB	∅ 12,0	19,0	Dichtring	Bi-Hex 14,0 (Doppel-sechskant *)			9			P	Mittlelektrode, Platin	-15	1,5
		KE	∅ 12,0	19,0	Dichtring	Hex 16,0			10			*Wenn am Anfang der Teilenummer „I“ oder „P“ steht („I“ oder „P“ nach dem Temperaturwert wird zum nachgestellten Zusatzcode.) <Beispiel> IZFR6P8 bedeutet Iridium-Zündkerze I: Iridium P: Zusatzcode * <Ausnahme> ZFROP-G bedeutet Nickel-Zündkerze		-A	kein Dichtring
	Oben angeführte Kennzeichen können kombiniert auftreten <Beispiel>ILFR..., PLZFR... Ist „L“ in der Markierung enthalten, erhält „L“ (lange Gewindelänge) Priorität bei der Gewindelänge. <Beispiel> * Kerze mit Dichtring FR5AP : Gewindelänge 19,0mm ↓ LFR5AP-11 : Gewindelänge 26,5mm * Kerze mit Kegeldichtsitz PTR5C-13 : Gewindelänge 17,5mm ↓ PLTR6A-10G : Gewindelänge 25,0mm	KF	∅ 12,0	19,0	Dichtring	Hex 14,0								-D	Metallhülse: Nickel-beschichtet
		KG	∅ 12,0	19,0	Dichtring	Bi-Hex 14,0 (Doppel-sechskant *)								-E	spezieller Widerstand
		L	∅ 10,0	12,7	Dichtring	Hex 16,0							-G	Masselektrode mit Kupferkern	
		M	∅ 10,0	19,0	Dichtring	Hex 16,0							-H	spezielles Gewinde	
		MA	∅ 10,0	19,0	Dichtring	Hex 14,0							-J	2 Massen-Elektroden	
		MF	∅ 10,0	19,0	Dichtring	Hex 14,0							-K	schwingungsfeste Masselektrode	
		NA	∅ 12,0	17,5	Kegeldichtsitz	Hex 14,0							-N	spezielle Massen-Elektrode	
		T	∅ 14,0	17,5	Kegeldichtsitz	Hex 16,0							-Q	4 Massen-Elektrode	
		U	∅ 14,0	11,2	Kegeldichtsitz	Hex 16,0							-S	spezieller Dichtring	
		W	∅ 18,0	10,9	Kegeldichtsitz	Hex 20,8							-T	3 Massen-Elektrode	
		X	∅ 14,0	9,5	Dichtring	Hex 20,8							-U	Halbleitfunktentyp	
		Y	∅ 14,0	11,2	Kegeldichtsitz	Hex 16,0							IX-P	Iridium MAX Kerze	
													LPG 1-8	LaserLine-Zündkerzenserie für gasbetriebene Motoren	

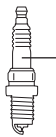

RE 7 C - L

RE		7		C		-L	
Zündkerzentyp		Wärmewert		Konstruktion		Elektrodenabstand	
RE	Zündkerze für Wankelmotor	5		A,B,C... Suffix code		-L	oberer Totpunkt
SD	Zündkerze für Wankelmotor (Halbleitfunktentyp)	6				-T	unterer Totpunkt
		7					
		8					
		9					
		10					
		11					

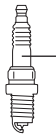

HB 6 A IX - 11 P

HB		6		A		IX		-11		P	
Zündkerzentyp		Wärmewert		Gewinde-durchmesser	Gewinde-länge	Sitzkonstruktion	Sechskant	Elektroden-abstand			
HB	HYBD (3 Masselektroden, Hybridbauart)	4		A	∅ 14,0	20,5	Dichtring	Hex 16,0	IX	-8	0,8
		5		B	∅ 14,0	19,0	Dichtring	Hex 16,0		-9	0,9
		6								-10	1,0
		7								-11	1,1
		8							-13	1,3	

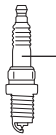

DF 6 H - 11 A

DF		6		H		-11		A		
Zündkerzentyp		Wärmewert		Gewinde-durchmesser	Gewinde-länge	Sitzkonstruktion	Sechskant	Elektroden-abstand		
DF	Zündkerze mit hoher Zündwilligkeit (Doppel-elektrode, dünn)	4		A	∅ 14,0	19,0	Dichtring	Hex 16,0	-8	0,8
		5		B	∅ 14,0	26,5	Dichtring	Hex 16,0	-9	0,9
DFH	Zündkerze mit hoher Zündwilligkeit (DF + Hybrid)	6		C	∅ 12,0	26,5	Dichtring	Hex 14,0	-10	1,0
		7		*DF6H-11A : Gewindelänge 28,0mm					-11	1,1
		8							-13	1,3
		9						-15	1,5	



Comment lire notre numéro de pièce: Bougies

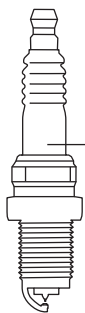

B P R 5 E S - 11

Unité : mm

B		P		R		5		E		S		-11	
Diamètre de filetage	Hexagone	Structure		Résistance antiparasitage		Indice thermique		Longueur du filetage		Caractéristiques de conception		Ecartement	
A	∅ 18,0	Hex 25,4	P	Isolant proéminent	R	Résistance	2	Type chaud	E	19,0	B	Olive SAE monbloque (CR8EB)	
B	∅ 14,0	Hex 20,8				Z			Inductance intégrée	4		Type froid	EF
BC	∅ 14,0	Hex 16,0	M	Bougie compacte	5		6	EH			19,0 semi-filetage Culot 19 mm Filetage 12,7		CS
BK	∅ 14,0	Hex 16,0				U			Décharge superficielle ou à étincelle semi-surfacique	7	8	H	
C	∅ 10,0	Hex 16,0	9	10	10		L	11,2					I
D	∅ 12,0	Hex 18,0				vide		Siège conique A(P)-F : 10,9 B(P)-F : 11,2 BM(P)-F : 7,8	vide	Siège conique A(P)-F : 10,9 B(P)-F : 11,2 BM(P)-F : 7,8	vide	Bougie de petite taille B(P)M : 9,5 B(L)M : 9,5 CM : 9,5 CM-6 : 8,6 C-50 : 8,5	
DC	∅ 12,0	Hex 16,0	J	2 électrodes de masse à projection	-11		1,1						
E	∅ 8,0	Hex 13,0				K	2 électrodes de masse	-13	1,3				
* Exception B(P)M-A.Y : ∅ 14,0, Hex 19,0 R(P)-(E)F : ∅ 14,0, Hex 16,0 CM-6 : ∅ 10,0, Hex 14,0		BC : Ancienne taille standard JIS La longueur entre le circuit du joint et le contact de la borne est de 53 mm.	-LM	Type compact (longueur isolant : 14,5 mm)	-15				1,5				
BK : Taille standard ISO/JIS La longueur entre le circuit du joint et le contact de la borne est de 50,5 mm.						N	Electrode de masse spéciale	-S	Joint spécifique				
		P	Electrode centrale en Platine Electrode de masse simple : Double platine Electrode à masses multiples : Platine simple dans l'électrode centrale	-E	Résistance spéciale								
					Q	4 électrodes de masse	IX-P	Bougie Iridium MAX					
		S	Electrode centrale en cuivre	LPG 1-8				Gamme de bougies d'allumage LaserLine pour utilisation sur moteur à gaz					
					T	3 électrodes de masse	U	à décharge semi-surfacique					
		Y	Electrode centrale à gorge en V - Proéminence sup. à 1mm	Z				Conception spéciale					

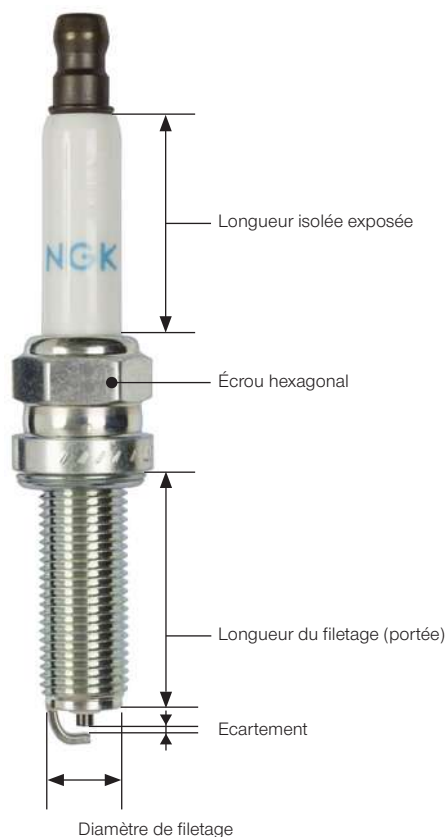

Comment lire notre numéro de pièce: Bougies

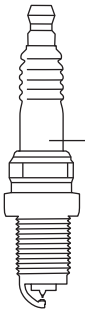

P F R 5 A - 11

Unité : mm

P		F				R		5		A		-11				
Type		Diamètre de filetage	Longueur du filetage	Configuration du siège	Hexagone	Résistance antiparasitage		Indice thermique		Conception		Distance entre les électrodes				
DI	Haute capacité d'allumage : technologie DFE	F	∅ 14,0	19,0	Joint	Hex 16,0	R	Résistance	2		A,B,C... code suffixe		leer	Moto : 0,7-0,8		
		FE	∅ 14,0	19,0	Joint	Hex 16,0			4					Automobile : 0,8-0,9		
I	Électrode centrale : Iridium Électrode de masse : Platine	G	∅ 14,0	19,0	Joint	Hex 20,8			5					-7	0,7	
		J	∅ 12,0	19,0	Joint	Hex 18,0			6					-9	0,9	
L	Filetage extra-long de 26,5mm	K	∅ 12,0	19,0	Joint	Hex 16,0			7			I	Électrode centrale en iridium	-10	1,0	
P	Bougie d'allumage double à la platine	KA	∅ 12,0	19,0	Joint	Hex 14,0			8						-11	1,1
S	Bougie haute sensibilité à l'allumage : type à pointe carrée fine	KB	∅ 12,0	19,0	Siège conique	Bi-Hex 14,0 (Bi-hexagonal *)			9			IX	Gamme Iridium IX	-13	1,3	
Z	Extrémité d'allumage projetée	KE	∅ 12,0	19,0	Joint	Hex 16,0			10		Type froid				P	Électrode centrale en platine
Les caractéristiques citées ci-dessus peuvent être combinées. <Exemple>ILFR..., PLZFR... Quand « L » est inclus, la priorité est donnée au « L » (longue portée) pour la longueur de filetage. <Exemple> *Bougie avec joint d'étanchéité FR5AP : longueur de filetage 19,0mm ↓ LFR5AP-11 : longueur de filetage 26,5mm *Bougie à siège conique PTR5C-13 : longueur de filetage 17,5mm ↓ PLTR6A-10G : longueur de filetage 25,0mm		KF	∅ 12,0	19,0	Joint	Hex 14,0						* Quand il y a « I » ou « P » au début du numéro de pièce (« I » ou « P » après la valeur thermique devient un code de suffixe.) <Exemple> IZFR6P8 est une bougie à l'iridium I : Iridium P : Code de suffixe * <Exception> ZFR6P-G est une bougie d'allumage au nickel		-A	Sans joint d'étanchéité	
		KG	∅ 12,0	19,0	Joint	Bi-Hex 14,0 (Bi-hexagonal *)								-D	Corps métallique : nickelé	
		L	∅ 10,0	12,7	Joint	Hex 16,0							-E	Résistance spéciale		
		M	∅ 10,0	19,0	Joint	Hex 16,0							-G	Électrode de masse à cœur en cuivre		
		MA	∅ 10,0	19,0	Joint	Hex 14,0							-H	Filetage spécial		
		MF	∅ 10,0	19,0	Joint	Hex 14,0							-J	2 électrodes de masse		
		NA	∅ 12,0	17,5	Siège conique	Hex 14,0							-K	Électrode de masse résistante aux vibrations		
		T	∅ 14,0	17,5	Siège conique	Hex 16,0							-N	Électrode de masse spéciale		
		U	∅ 14,0	11,2	Siège conique	Hex 16,0							-Q	4 électrodes de masse		
		W	∅ 18,0	10,9	Siège conique	Hex 20,8							-S	Joint spécifique		
		X	∅ 14,0	9,5	Joint	Hex 20,8							-T	3 électrodes de masse		
		Y	∅ 14,0	11,2	Siège conique	Hex 16,0							-U	Type à décharge sur demi-surface		
		* Exception TR5A-10, TR5A-13, TR5B-13, TR6B-10, TR6B-13, PTR5A-10, PTR5A-13 : Longueur de filetage 25 mm				Bi-hexagonal							IX-P	Bougie Iridium MAX		
		* Une douille bi-hexagonale est nécessaire.				Hexagonal							LPG 1-8	Gamme de bougies d'allumage LaserLine pour moteurs à gaz		
		* FE, KE, KF, KG, MF : Type à longueur d'isolant exposé plus longue														

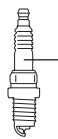

RE 7 C L

RE		7		C		-L	
Type		Indice thermique		Conception		Distance entre les électrodes	
RE	Bougie pour moteurs rotatifs	5		A,B,C... code suffixe		-L	Face avant
SD	Bougie pour moteurs rotatifs (écartement des électrodes à décharge sur demi-surface)	6				-T	Face arrière
		7					
		8					
		9					
		10					
		11	Type froid				

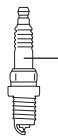

HB 6 A IX - 11 P

HB		6		A				IX		-11		P	
Type		Indice thermique		Diamètre de filetage	Longueur du filetage	Configuration du siège	Hexagone			Distance entre les électrodes			
HB	HYBD (type hybride à 3 électrodes de masse)	4		A	∅ 14,0	20,5	Joint	Hex 16,0	IX	-8	0,8		
		5		B	∅ 14,0	19,0	Joint	Hex 16,0		-9	0,9		
		6								-10	1,0		
		7								-11	1,1		
		8	Type froid						-13	1,3			

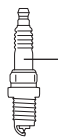

DF 6 H A - 11 A

DF		6		H				-11		A	
Type		Indice thermique		Diamètre de filetage	Longueur du filetage	Configuration du siège	Hexagone	Distance entre les électrodes			
DF	Bougie haute sensibilité à l'allumage	4		A	∅ 14,0	19,0	Joint	Hex 16,0	-8	0,8	A,B,C... code suffixe
		5		B	∅ 14,0	26,5	Joint	Hex 16,0	-9	0,9	
DFH	Bougie haute sensibilité à l'allumage (DF + type hybride)	6		C	∅ 12,0	26,5	Joint	Hex 14,0	-10	1,0	
		7		* DF6H-11A : Longueur du filetage 28,0 mm				-11	1,1		
		8						-13	1,3		
		9	Type froid					-15	1,5		



Come leggere il nostro numero del pezzo: Candele di accensione

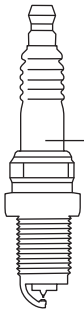

B P R 5 E S - 11

Unità: mm

B		P		R		5		E		S		-11																																													
	Diametro filettatura	esagono	Struttura	Resistore		Grado termico		Lunghezza filettatura		Caratteristiche costruttive		Gap																																													
A	∅ 18,0	Hex 25,4	P	punta isolatore prominente	R	Candela resistiva	2	candela calda	E	19,0	B	terminale SAE fisso (CR8EB)	leer	Motociclo : 0,7-0,8																																											
B	∅ 14,0	Hex 20,8	M	Candela compatta del tipo Bantam	Z	resistenza induttiva	4		EF	17,5	CM	Elettrodo inclinato di messa a terra Tipo compatto (lunghezza isolante visibile: 18,5)	-8	0,8																																											
BC	∅ 14,0	Hex 16,0					5		EH	19,0 parzialmente filettata																																															
BK	∅ 14,0	Hex 16,0	6	H	12,7	CS	Elettrodo inclinato di messa a terra		-9	0,9																																															
C	∅ 10,0	Hex 16,0	7	L	11,2																																																				
D	∅ 12,0	Hex 18,0	U	Candela a scarica superficiale o semisuperficiale		8	vuoto		Sede conica A(P)-F : 10,9 B(P)-F : 11,2 BM(P)-F : 7,8	I	Elettrodo centrale in iridio	-10	1,0																																												
DC	∅ 12,0	Hex 16,0				9								IX	Candela Iridium IX	-11	1,1																																								
E	∅ 8,0	Hex 13,0	10	candela fredda	10	Candela del tipo piccolo B(P)-M : 9,5 B-LM : 9,5 CM- : 9,5 CM-6 : 8,6 C-50 : 8,5	J		2 elettrodi di messa a terra prominenti	-13	1,3																																														
* Eccezione B(P)M-A.Y : ∅ 14,0, Hex 19,0 R(P)-(E)F : ∅ 14,0, Hex 16,0 CM-6 : ∅ 10,0, Hex 14,0																																																									
BC : Misura standard JIS precedente La lunghezza dalla guarnizione del circuito al terminale è di 53 mm.																																																									
BK : Misura standard ISO / JIS La lunghezza dalla guarnizione del circuito al terminale è di 50,5 mm.																																																									
<table border="1"> <tr> <td rowspan="2">-15</td> <td rowspan="2">1,5</td> <td rowspan="2">K</td> <td rowspan="2">2 elettrodi di messa a terra</td> </tr> <tr> <td>-LM</td> <td>Tipi compatti (lunghezza isolatore: 14,5)</td> </tr> <tr> <td>-S</td> <td>guarnizione anulare speciale</td> <td>N</td> <td>elettrodo di massa irrobustito</td> </tr> <tr> <td>-E</td> <td>Resistenza speciale</td> <td rowspan="2">P</td> <td>elettrodo al platino</td> </tr> <tr> <td>IX-P</td> <td>Candela all'iridio MAX</td> <td>Elettrodo di messa a terra singolo: Platino doppio</td> </tr> <tr> <td>LPG 1-8</td> <td>Gamma di candele LaserLine per motori a gas</td> <td rowspan="2">Q</td> <td>Elettrodo con messa a terra multipla; Elettrodo centrale singolo in platino</td> </tr> <tr> <td></td> <td></td> <td>4 elettrodi di messa a terra</td> </tr> <tr> <td></td> <td></td> <td>S</td> <td>Tipo standard</td> </tr> <tr> <td></td> <td></td> <td>T</td> <td>3 elettrodi di messa a terra</td> </tr> <tr> <td></td> <td></td> <td>U</td> <td>Tipo a scarica semi-superficiale</td> </tr> <tr> <td></td> <td></td> <td>Y</td> <td>Elettrodo centrale scanalato a V - V grooved -</td> </tr> <tr> <td></td> <td></td> <td>Z</td> <td>struttura speciale</td> </tr> </table>														-15	1,5	K	2 elettrodi di messa a terra	-LM	Tipi compatti (lunghezza isolatore: 14,5)	-S	guarnizione anulare speciale	N	elettrodo di massa irrobustito	-E	Resistenza speciale	P	elettrodo al platino	IX-P	Candela all'iridio MAX	Elettrodo di messa a terra singolo: Platino doppio	LPG 1-8	Gamma di candele LaserLine per motori a gas	Q	Elettrodo con messa a terra multipla; Elettrodo centrale singolo in platino			4 elettrodi di messa a terra			S	Tipo standard			T	3 elettrodi di messa a terra			U	Tipo a scarica semi-superficiale			Y	Elettrodo centrale scanalato a V - V grooved -			Z	struttura speciale
-15	1,5	K	2 elettrodi di messa a terra																																																						
				-LM	Tipi compatti (lunghezza isolatore: 14,5)																																																				
-S	guarnizione anulare speciale	N	elettrodo di massa irrobustito																																																						
-E	Resistenza speciale	P	elettrodo al platino																																																						
IX-P	Candela all'iridio MAX		Elettrodo di messa a terra singolo: Platino doppio																																																						
LPG 1-8	Gamma di candele LaserLine per motori a gas	Q	Elettrodo con messa a terra multipla; Elettrodo centrale singolo in platino																																																						
			4 elettrodi di messa a terra																																																						
		S	Tipo standard																																																						
		T	3 elettrodi di messa a terra																																																						
		U	Tipo a scarica semi-superficiale																																																						
		Y	Elettrodo centrale scanalato a V - V grooved -																																																						
		Z	struttura speciale																																																						



Come leggere il nostro numero del pezzo: Candele di accensione



P F R 5 A - 11

Unità: mm

P		F				R		5		A		-11			
Tipo candela		Diametro filettatura	Lunghezza filettatura	Configurazione della sede	esagono	Resistore		Grado termico		Costruzione		Gap			
DI	candela ad elevatissima accendibilità tipo DFE (Double Fine electrodes)	F	∅ 14,0	19,0	Guarnizione anulare	Hex 16,0	R	Resistenza	2		A,B,C... Suffix code		vuoto	Motociclo: 0,7-0,8 Auto : 0,8-0,9	
I	Elettrodo centrale: Iridio Elettrodo di massa: Platino	FE	∅ 14,0	19,0	Guarnizione anulare	Hex 16,0			4					-7	0,7
		G	∅ 14,0	19,0	Guarnizione anulare	Hex 20,8			5					-9	0,9
		J	∅ 12,0	19,0	Guarnizione anulare	Hex 18,0			6						
L	candela a filettatura estesa	K	∅ 12,0	19,0	Guarnizione anulare	Hex 16,0			7			I	Elettrodo centrale in iridio	-10	1,0
P	Candele al doppio platino	KA	∅ 12,0	19,0	Guarnizione anulare	Hex 14,0			8			IX	Candela Iridium IX	-11	1,1
S	Alta accendibilità della candela: punta del tipo sottile quadrangolare	KB	∅ 12,0	19,0	Guarnizione anulare	Bi-Hex 14,0 (Bi-esagonale *)			9			P	Elettrodo centrale in platino	-13	1,3
		KE	∅ 12,0	19,0	Guarnizione anulare	Hex 16,0			10					-15	1,5
Z	Elettrodo prominente	KF	∅ 12,0	19,0	Guarnizione anulare	Hex 14,0									
		KG	∅ 12,0	19,0	Guarnizione anulare	Bi-Hex 14,0 (Esagonale*)									
I codici sopraindicati possono presentarsi in varie combinazioni, <Esempio>ILFR--, PLZFR--. Quando è inclusa una „L“, la priorità viene data alla „L“ (braccio lungo) per la lunghezza della filettatura. <Esempio> *Candela con guarnizione anulare FR5AP : lunghezza filettatura 19,0mm ↓ LFR5AP-11 : lunghezza filettatura 26,5mm *Candela con sede conica PTR5C-13 : lunghezza filettatura 17,5mm ↓ PLTR6A-10G : lunghezza filettatura 25,0mm *Fatta eccezione per TR5A-10, TR5A-13, TR5B-13, TR6B-10, TR6B-13, PT-R5A-10, PTR5A-13: Lunghezza della filettatura 25,0mm *È necessario un attacco bi-esagonale. *FE, KE, KF, KG, MF: Tipo con isolante visibile più lungo		L	∅ 10,0	12,7	Guarnizione anulare	Hex 16,0							-A	senza guarnizione anulare	
		M	∅ 10,0	19,0	Guarnizione anulare	Hex 16,0								-D	Supporto in metallo: nichelatura
		MA	∅ 10,0	19,0	Guarnizione anulare	Hex 14,0								-E	resistenza speciale
		MF	∅ 10,0	19,0	Guarnizione anulare	Hex 14,0								-G	Elettrodo di terra con nucleo in rame
		NA	∅ 12,0	17,5	Sede conica	Hex 14,0								-H	Filettatura speciale
		T	∅ 14,0	17,5	Sede conica	Hex 16,0								-J	2 elettrodi di massa
		U	∅ 14,0	11,2	Sede conica	Hex 16,0								-K	Elettrodo di terra resistente alle vibrazioni
		W	∅ 18,0	10,9	Sede conica	Hex 20,8								-N	Elettrodo di massa speciale
		X	∅ 14,0	9,5	Guarnizione anulare	Hex 20,8								-Q	4 elettrodi di massa
		Y	∅ 14,0	11,2	Sede conica	Hex 16,0								-S	Guarnizione anulare speciale
												-T	3 elettrodi di massa		
												-U	Tipo a scarica semi-superficiale		
												IX-P	Candela all'iridio MAX		
												LPG 1-8	Gamma di candele LaserLine per motori a gas		

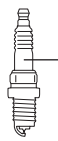

RE 7 C - L

RE		7		C		-L	
Tipo candela		Grado termico		Costruzione		Gap	
RE	Candela per motori rotativi	5		A,B,C... Suffix code		-L	Leading side
SD	Candela per motori rotativi (distanza tra gli elettrodi a scarica semi-superficiale)	6				-T	Trading side
		7					
		8					
		9					
		10					
		11					

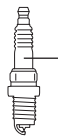

HB 6 A IX - 11 P

HB		6		A				IX		-11		P	
Tipo candela		Grado termico		Diametro filettatura	Lunghezza filettatura	Configurazione della sede	esagono			Gap			
HB	HYBD (tipo ibrido con 3 elettrodi di messa a terra)	4		A	∅ 14,0	20,5	Guarnizione anulare	Hex 16,0	IX	-8	0,8		
		5		B	∅ 14,0	19,0	Guarnizione anulare	Hex 16,0		-9	0,9		
		6								-10	1,0		
		7								-11	1,1		
		8							-13	1,3			

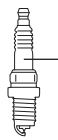

DF 6 H - 11 A

DF		6		H				-11		A	
Tipo candela		Grado termico		Diametro filettatura	Lunghezza filettatura	Configurazione della sede	esagono	Gap			
DF	Candela ad alta accendibilità (elettrodi sottili doppi)	4		A	∅ 14,0	19,0	Guarnizione anulare	Hex 16,0	-8	0,8	A,B,C... Suffix code
		5		B	∅ 14,0	26,5	Guarnizione anulare	Hex 16,0	-9	0,9	
DFH	Candela ad alta accendibilità (DF + tipo ibrido)	6		C	∅ 12,0	26,5	Guarnizione anulare	Hex 14,0	-10	1,0	
		7		*DF6H-11A : Lunghezza filettatura 28,0mm				-11	1,1		
		8						-13	1,3		
		9					-15	1,5			



Cómo leer nuestros números de pieza: Bujías

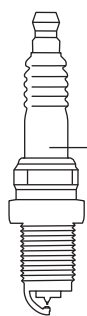

B P R 5 E S - 11

Unidad: mm

B		P		R		5		E		S		-11			
Diámetro de la rosca	Tamaño del Hexágono	Estructura		Construcción / Características		Grado térmico		Longitud de la rosca		Características constructivas		Galga (mm), Nada: Galga convencional			
A	∅ 18,0	Hex 25,4	P	Tipo aislador proyectado	R	Tipo Resistencia	2		E	19,0	B	Tuerca terminal SAE fija (CR8EB)	vacio	Motocicleta: 0,7 - 0,8 mm	
B	∅ 14,0	Hex 20,8			Z	Tipo Resistencia inductiva	4		5	EF	17,5	CM		Electrodo de masa inclinado Tipo compacto (longitud de aislador expuesto: 18,5)	Automóvil: 0,8 - 0,9 mm
BC	∅ 14,0	Hex 16,0	M	Tipo Compacto (Bantam)		6	EH		Media rosca, Total: 19,00 mm, Rosca I: 12,7 mm	CS	Electrodo de masa inclinado	-8	0,8		
BK	∅ 14,0	Hex 16,0				7	H		12,7	G,GV	Bujía de competición	-9	0,9		
C	∅ 10,0	Hex 16,0	U	Tipo descarga superficial o semi-superficial		8	L		11,2	I	Electrodo central de iridio	-10	1,0		
D	∅ 12,0	Hex 18,0				9	vacío		Asiento cónico A(P)-F: 10,9 B(P)-F: 11,2 BM(P)-F: 7,8	IX	Electrodo de iridio IX	-11	1,1		
DC	∅ 12,0	Hex 16,0				10			Bujía de tipo pequeño B(P)M: 9,5 B(L)M: 9,5 CM: 9,5 CM-6: 8,6 C-50: 8,5	J	2 electrodos de masa prominentes	-13	1,3		
E	∅ 8,0	Hex 13,0									K	2 electrodos de masa	-15	1,5	
*Excepción B(P)M-A,Y : ∅ 14,0, Hex 19,0 P(P)-(E)F : ∅ 14,0, Hex 16,0 CM-6 : ∅ 10,0, Hex 14,0		BC : Altura JIS estándar antigua La longitud desde el asiento a la parte superior del terminal es de 53,0 mm.									-LM		Tipo compacto (longitud del aislante: 14,5 mm)		
BK : Altura estándar ISO/JIS La longitud desde el asiento a la parte superior del terminal es de 50,5 mm.											N		Electrodo especial de masa		
										P		Electrodo de platino Un solo electrodo de masa: doble platino Varios electrodos de masa: platino sencillo en el electrodo central			
										Q		4 electrodos de masa			
										S		Tipo estándar			
										T		3 electrodos de masa			
										U		Tipo descarga semi superficial			
										Y		Electrodo central con ranurado en V			
										Z		Fabricación especial			
										IX-P		Bujía Iridium MAX			
										LPG 1-8		Gama de bujías LaserLine para motores de gas			



Hoe moet ons onderdeelnummer worden gelezen: Bougies

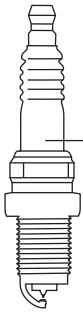

Eenheid: mm

B		P		R		5		E		S		-11			
	Schroefdraaddiameter	Zeskant	Structuur		Ontstoringweerstand		Warmtewaarde		Schroefdraadlengte		Constructiekenmerken		Elektrodeafstand		
A	∅ 18,0	Hex 25,4	P	Verschuiven isolatorpunt	R	Weerstand	2		E	19,0	B	aste SAE-aansluitmoer (CR8EB)	Leeg	Motorrijwiel : 0,7-0,8	
B	∅ 14,0	Hex 20,8			Z	Inductieve weerstand	4		EF	17,5	CM	Schuine massa-elektrode Compact type (Onbeschermde isolatorlengte: 18,5)			Auto : 0,8-0,9
BC	∅ 14,0	Hex 16,0	M	Compacte bougie			5		EH	19,0 voor de helft uitgevoerd	CS	Schuine massa-elektrode	-8	0,8	
BK	∅ 14,0	Hex 16,0					6		H	12,7	G,GV	Racebougie	-9	0,9	
C	∅ 10,0	Hex 16,0	U	Glijvonk-type of extra vonktraject			7		L	11,2	I	Middenelektrode van iridium	-10	1,0	
D	∅ 12,0	Hex 18,0					8		Leeg	Conische zitting A(P)F : 10,9 B(P)F : 11,2 BM(P)F : 7,8	J	2-projecterende-massa-elektrodes	-13	1,3	
DC	∅ 12,0	Hex 16,0					9			Kleine bougie B(P)M : 9,5 B(L)M : 9,5 CM : 9,5 CM-6 : 8,6 C-50 : 8,5	K	2-massa-elektrodes	-15	1,5	
E	∅ 8,0	Hex 13,0					10				-LM	Compact type (isolatorlengte: 14,5mm)			
* Uitzondering B(P)M-A,Y : ∅ 14,0, Hex 19,0 P(P)-(E)F : ∅ 14,0, Hex 16,0 CM-6 : ∅ 10,0, Hex 14,0											N	Speciale massa-elektrode	-S	Speciale dichtring	
BC : Oude JIS-standaardgrootte De lengte van pakkingcircuit naar eindcontact bedraagt 53,0 mm.											P	Platina elektrode Enkele massa-elektrode Meerdere massa-elektrodes van dubbel platina: Enkel platina in middenelektrode	-E	Speciale weerstand	
BK : ISO / JIS standaardgrootte De lengte van pakkingcircuit naar eindcontact bedraagt 50,5 mm.												IX-P	Iridium MAX-bougie		
										Q	4-massa-elektrodes	LPG 1-8	LaserLine bougieassortiment voor gebruik in gasmotoren		
										S	Standaard type				
										T	3-massa-elektrodes				
										U	Type halfglijvonk				
										Y	Middenelektrode met V-inkepin				
										Z	Speciale constructie				



Hoe moet ons onderdeelnummer worden gelezen: Bougies

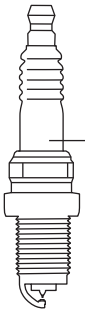

P F R 5 A - 11

Eenheid: mm

P		F				R		5		A		-11			
Bougie Type		Schroefdraad-diameter	Schroef-draadlengte	Zitting-configuratie	Zeskant	Ontstortingsweerstand		Warmtewaarde		Constructie		Elektrodeafstand			
DI	Extreme onbrandbaarheid, dubbel uitgevoerde, fijne elektroden	F	∅ 14,0	19,0	Dichtring	Hex 16,0	R	Résistance	2		A,B,C... Suffix code		leer	Motorrijwiel : 0,7-0,8 Auto : 0,8-0,9	
		FE	∅ 14,0	19,0	Dichtring	Hex 16,0			4						
I	Centrale elektrode: Iridium Massa elektrode: Platina	G	∅ 14,0	19,0	Dichtring	Hex 20,8			5					-7	0,7
		J	∅ 12,0	19,0	Dichtring	Hex 18,0			6					-9	0,9
L	Bijzonder lange schroefdraad 26,5mm	K	∅ 12,0	19,0	Dichtring	Hex 16,0			7			I	Middenelektrode van iridium	-10	1,0
P	Dubbel platina bougie	KA	∅ 12,0	19,0	Dichtring	Hex 14,0			8			IX	Iridium bougie	-11	1,1
S	Hoog ontvlambare bougie: type dun vierkant uiteinde	KB	∅ 12,0	19,0	Conische zitting	Bi-Hex 14,0 (Dubbele zeskant *)			9			P	Middenelektrode van platina	-13	1,3
Z	Uitstekende elektrode	KE	∅ 12,0	19,0	Dichtring	Hex 16,0			10		Koud type			-15	1,5
	Hierboven genoemde kenmerken kunnen gecombineerd optreden, <Voorbeeld>LFR..., PLZFR... Wanneer „L“ is inbegrepen, wordt in de draadlengte prioriteit aan „L“ (lang bereik) gegeven. <Voorbeeld> *Bougie met dichtring FR5AP : draadlengte 19,0mm ↓ LFR5AP-11 : draadlengte 26,5mm *Bougie met conische zitting PTR5C-13 : draadlengte 17,5mm ↓ PLTR6A-10G : draadlengte 25,0mm	KF	∅ 12,0	19,0	Dichtring	Hex 14,0						*Wanneer „I“ of „P“ aan het begin van het onderdeelnummer staat („I“ of „P“ na warmtegraad wordt suffixcode.) <Voorbeeld> IZFR6P8 is iridium bougie I: Iridium P: Suffixcode *<Uitzondering> ZFR6P-G is bougie van nikkel		-A	Geen dichtring
		KG	∅ 12,0	19,0	Dichtring	Bi-Hex 14,0 (Dubbele zeskant *)								-D	Metalen behuizing: vernikkeld
		L	∅ 10,0	12,7	Dichtring	Hex 16,0							-E	Speciale weerstand	
		M	∅ 10,0	19,0	Dichtring	Hex 16,0							-G	Massa-elektrode met koperen kern	
		MA	∅ 10,0	19,0	Dichtring	Hex 14,0							-H	Speciale schroefdraad	
		MF	∅ 10,0	19,0	Dichtring	Hex 14,0							-J	2 massa-elektroden	
		NA	∅ 12,0	17,5	Conische zitting	Hex 14,0							-K	Trilbestendige massa-elektrode	
		T	∅ 14,0	17,5	Conische zitting	Hex 16,0							-N	Speciale massa-elektrode	
		U	∅ 14,0	11,2	Conische zitting	Hex 16,0							-Q	4 massa-elektroden	
		W	∅ 18,0	10,9	Conische zitting	Hex 20,8							-S	Speciale dichtring	
		X	∅ 14,0	9,5	Dichtring	Hex 20,8							-T	3 massa-elektroden	
		Y	∅ 14,0	11,2	Conische zitting	Hex 16,0							-U	Type halfglijvonkcontacting	
						Dubbele zeskant							IX-P	Iridium MAX-bougie	
						Zeskant							LPG 1-8	LaserLine bougieassortiment voor gasmotoren	

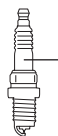

RE 7 C L

RE		7		C		-L	
Bougie Type		Warmtewaarde		Constructie		Elektrodeafstand	
RE	Bougie voor rotatiemotoren	5		A,B,C... Suffix code		-L	Geleidende zijde
SD	Bougie voor rotatiemotoren (Opening halfglijvonkcontacting)	6				-T	Uitwiselende zijde
		7					
		8					
		9					
		10					
		11	Koud type				

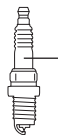

HB 6 A IX - 11 P

HB		6		A				IX		-11		P	
Bougie Type		Warmtewaarde		Schroefdraad-diameter	Schroefdraad-lengte	Zitting-configuratie	Zeskant			Elektrodeafstand			
HB	HYBD (3-massa-elektrode hybride type)	4		A	∅ 14,0	20,5	Joint	Hex 16,0	IX	-8	0,8		
		5		B	∅ 14,0	19,0	Joint	Hex 16,0		-9	0,9		
		6								-10	1,0		
		7								-11	1,1		
		8	Koud type						-13	1,3			

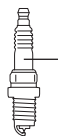

DF 6 H - 11 A

DF		6		H				-11		A	
Bougie Type		Warmtewaarde		Schroefdraad-diameter	Schroefdraad-lengte	Zitting-configuratie	Zeskant	Elektrodeafstand		A,B,C... Suffix code	
DF	Hoog ontvlambare bougie (Dubbele fijne elektrodes)	4		A	∅ 14,0	19,0	Joint	Hex 16,0	-8	0,8	A,B,C... Suffix code
		5		B	∅ 14,0	26,5	Joint	Hex 16,0	-9	0,9	
DFH	Hoog ontvlambare bougie (DF + hybride type)	6		C	∅ 12,0	26,5	Joint	Hex 14,0	-10	1,0	
		7		*DF6H-11A : Schroefdraadlengte 28,0 mm				-11	1,1		
		8						-13	1,3		
		9	Koud type					-15	1,5		



Como ler o nosso número de peça: Velas de ignição

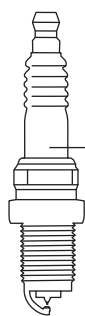

B P R 5 E S - 11

Unidade : mm

B		P		R		5		E		S		-11				
Tamanho da rosca	Tamanho do hexágono	Estrutura		Construçã		Número de potência térmica		Alcance da rosca		Características construtivas		Espaço da vela (mm)				
A	φ 18,0	Hex 25,4	P	Isolador projetado	R	Resistência	2		E	19,0	B	Porca SAE fixa (CR8EB)		Vazio	Mota: 0,7 - 0,8 mm	
B	φ 14,0	Hex 20,8			Z	Resistência indutiva	4		5	EF		17,5	CM		Eléctrodo de terra oblíquo Tipo compacto (Comprimento do isolador exposto: 18,5)	
BC	φ 14,0	Hex 16,0	M	Vela compacta (Bantam)		5	6		EH	19,0 executado até à metade	CS	Eléctrodo de terra oblíquo		-8	0,8	
BK	φ 14,0	Hex 16,0				6	7		H	12,7		G,GV	Vela de competição		-9	0,9
C	φ 10,0	Hex 16,0	U	Descarga superficial ou semi-surface		7	8		L	11,2	I		Eléctrodo central de irídio		-10	1,0
D	φ 12,0	Hex 18,0				8	9		Vazio	Assento cónico A(P)F : 10,9 B(P)F : 11,2 BM(P)F : 7,8		J	2 eléctrodos de terra projetores		-13	1,3
DC	φ 12,0	Hex 16,0	9	10		K	Ficha de tipo pequeno B(P)M : 9,5 B-LM : 9,5 CM : 9,5 CM-6 : 8,6 C-50 : 8,5			2 eléctrodos de terra			-15	1,5		
E	φ 8,0	Hex 13,0	10				-LM				Tipo compacto (Comprimento isolador: 14,5mm)		N	Eléctrodo de massa especial		-S
* Exceção B(P)M-A,Y : φ 14,0, Hex 19,0 P(P)-(E)F : φ 14,0, Hex 16,0 CM-6 : φ 10,0, Hex 14,0		BC : Antigo JIS tamanho padrão O comprimento do circuito da junta ao contacto terminal é de 53,0 mm.		BK : ISO / JIS tamanho padrão O comprimento do circuito da junta ao contacto terminal é de 50,5mm.					P	Eléctrodo de platina Eléctrodo de terra simples: Dupla platina		IX-P		Ficha MAX de Iridio		
										Eléctrodo de multi-terra: Platina simples em eléctrodo central			LPG 1-8	LGamma de vela de ignição LaserLine para uso em motor a gás		
										Q	4 eléctrodos de terra					
										S	Tipo padrão					
										T	3 eléctrodos de terra					
										U	Tipo faísca semi-deslizante					
										Y	Eléctrodo central com corte em V					
										Z	Construção especial					



Como ler o nosso número de peça: Velas de ignição

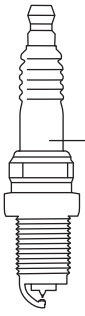

P F R 5 A - 11

Unidade : mm

P		F				R		5		A		-11	
Tipo de vela		Tamanho da rosca	Tamanho da rosca	Configuração do assento	Tamanho do hexágono	Construção		Número de potência térmica		Construção		Espaço da vela	
DI	Ignibilidade especialmente alta, eléctrodos finos de execução dupla	F	∅ 14,0	19,0	Junta circular	Hex 16,0	R	Resistência	2		A,B,C... Código sufixo	vacío	
		FE	∅ 14,0	19,0	Junta circular	Hex 16,0			4			Mota: 0,7-0,8 Carro: 0,8-0,9	
I	Eletrodo central: Iridium Eletrodo de terra: Platina	G	∅ 14,0	19,0	Junta circular	Hex 20,8	5		-7		0,7		
		J	∅ 12,0	19,0	Junta circular	Hex 18,0	6		-9		0,9		
L	Rosca especialmente longa	K	∅ 12,0	19,0	Junta circular	Hex 16,0	7		I		Eléctrodo central de irídio	-10	1,0
P	Vela de ignição de platina dupla	KA	∅ 12,0	19,0	Junta circular	Hex 14,0	8		IX		Vela de irídio	-11	1,1
S	Ficha de alta inflamabilidade: tipo ponta quadrada fina	KB	∅ 12,0	19,0	Junta circular	Bi-Hex 14,0 (Bi-sextavado *)	9		P		Eléctrodo central de platina	-15	1,5
		KE	∅ 12,0	19,0	Junta circular	Hex 16,0	10	Mais frio					
Z	Ponta de ignição projetada	KF	∅ 12,0	19,0	Junta circular	Hex 14,0							
		KG	∅ 12,0	19,0	Junta circular	Hex 14,0							
		L	∅ 10,0	12,7	Junta circular	Hex 16,0							
		M	∅ 10,0	19,0	Junta circular	Hex 16,0							
		MA	∅ 10,0	19,0	Junta circular	Hex 14,0							
		MF	∅ 10,0	19,0	Junta circular	Hex 14,0							
		NA	∅ 12,0	17,5	Assento cónico	Hex 14,0							
		T	∅ 14,0	17,5	Assento cónico	Hex 16,0							
		U	∅ 14,0	11,2	Assento cónico	Hex 16,0							
		W	∅ 18,0	10,9	Assento cónico	Hex 20,8							
	Os códigos acima indicados podem aparecer em combinação, <Exemplo>ILFR..., PLZFR... Quando „L“ é incluído, a prioridade é dada a „L“ (longo alcance)* em comprimento do fio. <Exemplo> *Vela com junta circular FR5AP-11; comprimento da rosca 19,0 mm ↓ LFR5AP-11; comprimento da rosca 26,5mm *Vela com assento cónico PTR5C-13; comprimento da rosca 17,5 mm ↓ PLTR6A-10G; comprimento da rosca 25,0 mm	X	∅ 14,0	9,5	Junta circular	Hex 20,8							
		Y	∅ 14,0	11,2	Assento cónico	Hex 16,0							
		* Exceção TR5A-10, TR5A-13, TR5B-13, TR6B-10, TR6B-13, PTR5A-10, PTR5A-13: Comprimento do fio de 25,0 mm				Bi-sextavado							
		* O perno bi-sextavado é necessário.				Sextavado							
		* FE, KE, KF, KG, MF : Tipo de comprimento de isolador mais tempo exposto											

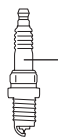

RE 7 C - L

RE		7		C		-L	
Tipo de vela		Número de potência térmica		Construção		Espaço da vela	
RE	Vela para motores rotativos	5		A,B,C... Código sufixo		-L Lado de liderança	
SD	Vela para motores rotativos (Espaço de descarga de semi-superfície)	6				-T Lado de mudança	
		7					
		8					
		9					
		10					
		11					

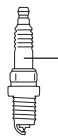

HB 6 A IX - 11 P

HB		6		A				IX		-11		P	
Tipo de vela		Número de potência térmica		Tamanho da rosca	Tamanho da rosca	Configuração do assento	Tamanho do hexágono			Espaço da vela			
HB	HYBD (3 eléctrodos de terra tipo híbrido)	4		A	∅ 14,0	20,5	Con Junta	Hex 16,0	IX	-8	0,8		
		5		B	∅ 14,0	19,0	Con Junta	Hex 16,0		-9	0,9		
		6						-10		1,0			
		7						-11		1,1			
		8					-13	1,3					

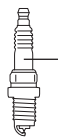

DF 6 H - 11 A

DF		6		H				-11		A		
Tipo de vela		Número de potência térmica		Tamanho da rosca	Tamanho da rosca	Configuração do assento	Tamanho do hexágono	Espaço da vela				
DF	Vela de alta inflamabilidade (eléctrodos finos duplos)	4		A	∅ 14,0	19,0	Con Junta	Hex 16,0	-8	0,8	A,B,C... Código sufixo	
		5		B	∅ 14,0	26,5	Con Junta	Hex 16,0	-9	0,9		
DFH	Vela de alta inflamabilidade (DF + Tipo híbrido)	6		C	∅ 12,0	26,5	Con Junta	Hex 14,0	-10	1,0		
		7						-11	1,1			
		8						-13	1,3			
		9						-15	1,5			
		* DF6H-11A : Tamanho da rosca 28,0 mm										



Πώς να ερμηνεύετε τους κωδικούς μας: Μπουζί

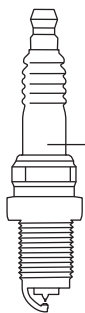

B P R 5 E S - 11

Μονάδα: mm

B		P		R		5		E		S		-11			
Διάμετρος σπειρώματος	εξάγωνο	Δομή		Αντιπαρασπαιτική αντίσταση		Τιμή θερμότητας		Μήκος σπειρώματος		Χαρακτηριστικά κατασκευής		Διάκενο ηλεκτροδίου			
A	φ 18,0	Hex 25,4	P	προωθημένο άκρο μονωτήρα	R	Αντίσταση	2		E	19,0	B	σταθερό παξιμάδι σύνδεσης SAE (CR8EB)	κενό	Μοτοσικλέτα: 0,7-0,8	
B	φ 14,0	Hex 20,8					Z		επαγωγική αντίσταση	4				EF	17,5
BC	φ 14,0	Hex 16,0	M	Συμπαγές μπουζί	5	H	12,7		CS	Ηλεκτρόδιο γείωσης	-8	0,8			
BK	φ 14,0	Hex 16,0			6	7	L				11,2	G,GV	Αγωνιστικό μπουζί	-9	0,9
C	φ 10,0	Hex 16,0	U	Τύπος ολισθαίνοντα σπινθήρα ή πρόσθετης διαδρομής σπινθήρα	8	κενό	Κωνική στεγανή εφαρμογή A(P)-F : 10,9 B(P)-F : 11,2 BM(P)-F : 7,8		IX	Μπουζί ιριδίου	-10			1,0	
D	φ 12,0	Hex 18,0			9						10	ψυχροί τύποι	Μπουζί μικρού τύπου B(P)M : 9,5 B-LM : 9,5 CM-6 : 9,5 CM-6 : 8,6 C-50 : 8,5	J	Ηλεκτρόδια που προεξέχουν από το έδαφος
DC	φ 12,0	Hex 16,0	E	φ 8,0	Hex 13,0	K	2 ηλεκτρόδια γείωσης		N	ειδικό ηλεκτρόδιο γείωσης	-13				
E	φ 8,0	Hex 13,0									-LM	Συμπαγείς τύποι(Μήκος μονωτήρα: 14,5 mm)	P	Ηλεκτρόδιο πλατίνας Απλό ηλεκτρόδιο γείωσης: Διπλή πλατίνα Πολλαπλά ηλεκτρόδια γείωσης: Μονή πλατίνα σε κεντρικό ηλεκτρόδιο	Q
<p>* Έξαιρηση B(P)M-A,Y : φ 14,0, Hex 19,0 P(P)-(E)F : φ 14,0, Hex 16,0 CM-6 : φ 10,0, Hex 14,0</p> <p>BC : Παλιό JIS κανονικό μέγεθος Το μήκος από το κύκλωμα φλάντζας ως την επαφή θερματικού είναι 53,0mm.</p> <p>BK : ISO / JIS κανονικό μέγεθος 50,5mm. Το μήκος από το κύκλωμα φλάντζας ως την επαφή θερματικού είναι 50,5mm.</p>															
													-E	ειδική αντίσταση	
													IX-P	Μπουζί MAX ιριδίου	
													LPG 1-8	LaserLine σειρά μπουζί για βενζινοκινητήρες	
													S	Στάνταρ τύπος	
													T	Τριπλά ηλεκτρόδια γείωσης	
													U	Τύπος σπινθήρα μισής ολισθησης	
													Y	Μεσαίο ηλεκτρόδιο με εγκοπή V	
													Z	ειδική κατασκευή	



Πώς να ερμηνεύετε τους κωδικούς μας: Μπουζί

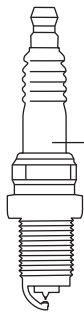

P F R 5 A - 11

Μονάδα: mm

P		F				R		5		A		-11		
Τύπος		Διάμετρος σπειρώματος	Μήκος σπειρώματος	Διαμόρφωση θέσης	εξάγωνο	Αντικαταστατική αντίσταση		Τιμή θερμότητας		Κατασκευή		Διάκενο ηλεκτροδίου		
DI	ιδιαίτερα υψηλή ικανότητα ανάφλεξης, λεπτά ηλεκτρόδια διπλής εκτέλεσης	F	∅ 14,0	19,0	Στεγανοποιητικός δακτύλιος	Hex 16,0	R	Αντίσταση	2	<p>θερμός τύπος</p> <p>ψυχροί τύποι</p>	A, B, C... Suffix code	κενό	Μοτοσικλέτα: 0,7-0,8 Αυτοκίνητο: 0,8-0,9	
I	Κεντρικό ηλεκτρόδιο: Ιριδίο Ηλεκτρόδιο γείωσης: πλατίνα	FE	∅ 14,0	19,0	Στεγανοποιητικός δακτύλιος	Hex 16,0		4	-7		0,7			
L	ιδιαίτερα μακρύ σπείρωμα	G	∅ 14,0	19,0	Στεγανοποιητικός δακτύλιος	Hex 20,8		5	-9		0,9			
P	Διπλό μπουζί πλατίνας	J	∅ 12,0	19,0	Στεγανοποιητικός δακτύλιος	Hex 18,0		6	I		Κεντρικό ηλεκτρόδιο ιριδίου	-10	1,0	
S	Μπουζί υψηλής αναφλεξιμότητας: τύπος λεπτής τετράγωνης άκρης	K	∅ 12,0	19,0	Στεγανοποιητικός δακτύλιος	Hex 16,0		7	IX		Μπουζί ιριδίου	-11	1,1	
Z	Προβλεπόμενη θέση πυροδότησης	KA	∅ 12,0	19,0	Στεγανοποιητικός δακτύλιος	Hex 14,0		8	P		Κεντρικό ηλεκτρόδιο πλατίνας	-13	1,5	
		KB	∅ 12,0	19,0	Στεγανοποιητικός δακτύλιος	Bi-Hex 14,0 (Διπλή εξαγωνική *)		9						
		KE	∅ 12,0	19,0	Στεγανοποιητικός δακτύλιος	Hex 16,0		10						
		KF	∅ 12,0	19,0	Στεγανοποιητικός δακτύλιος	Hex 14,0								
		KG	∅ 12,0	19,0	Στεγανοποιητικός δακτύλιος	Bi-Hex 14,0 (Διπλή εξαγωνική *)								
		L	∅ 10,0	12,7	Στεγανοποιητικός δακτύλιος	Hex 16,0								
		M	∅ 10,0	19,0	Στεγανοποιητικός δακτύλιος	Hex 16,0								
		MA	∅ 10,0	19,0	Στεγανοποιητικός δακτύλιος	Hex 14,0								
		MF	∅ 10,0	19,0	Στεγανοποιητικός δακτύλιος	Hex 14,0								
		NA	∅ 12,0	17,5	Κωνική στεγανή εφαρμογή	Hex 14,0								
		T	∅ 14,0	17,5	Κωνική στεγανή εφαρμογή	Hex 16,0								
		U	∅ 14,0	11,2	Κωνική στεγανή εφαρμογή	Hex 16,0								
		W	∅ 18,0	10,9	Κωνική στεγανή εφαρμογή	Hex 20,8								
		X	∅ 14,0	9,5	Στεγανοποιητικός δακτύλιος	Hex 20,8								
		Y	∅ 14,0	11,2	Κωνική στεγανή εφαρμογή	Hex 16,0								
						Διπλή εξαγωνική								
						Εξαγωνική								

Τα παραπάνω αναφερόμενα χαρακτηριστικά μπορεί να παρουσιαστούν συνδυασμένα, <Παράδειγμα> IFR..., PLZFR..., Όταν συμπεριλαμβάνεται „L“, δίνεται προτεραιότητα στο „L“ (μεγάλη εμβέλεια) στο μήκος σπειρώματος.

<Παράδειγμα> * Μπουζί με στεγανοποιητικό δακτύλιο

FR5AP : μήκος σπειρώματος 19,0mm
↓
LFR5AP-11 : μήκος σπειρώματος 26,5mm

* μπουζί με κωνική στεγανή εφαρμογή

PTR5C-13 : μήκος σπειρώματος 17,5mm
↓
PLTR6A-10G : μήκος σπειρώματος 25,0mm

* Εξαιρέση TR5A-10, TR5A-13, TR5B-13, TR6B-10, TR6B-13, PTR5A-10, PTR5A-13 : μήκος σπειρώματος 25,0mm

* Απαιτείται διπλή εξαγωνική υποδοχή.

* FE, KE, KF, KG, MF : Τύπος μήκους μακρύτερου εκτεθειμένου μονωτή

* Όταν υπάρχει „I“ ή „P“ στην αρχή του αριθμού αναφοράς εξαρτήματος (Το „I“ ή „P“ μετά τη θερμική ισχύ γίνεται κωδικός κατάληξης.)

<Παράδειγμα> Το IZFR6P8 είναι μπουζί ιριδίου
I : Ιριδίου
P : Κωδικός κατάληξης

* <Εξαιρέση> Το ZFR6P-G είναι μπουζί νικελίου

* -A χωρίς στεγανοποιητικό δακτύλιο
* -D Μεταλλικό περίβλημα : επικάλυψη
* -E ειδική αντίσταση
* -G Ηλεκτρόδιο γείωσης χαλκού
* -H ειδικό σπείρωμα
* -J 2 Ηλεκτρόδια γείωσης
* -K Καλώδιο γείωσης αντίστασης δόνησης
* -N ειδικό ηλεκτρόδιο γείωσης
* -Q 4 Ηλεκτρόδια γείωσης
* -S ειδικός στεγανοποιητικός δακτύλιος
* -T 3 Ηλεκτρόδια γείωσης
* -U Τύπος εκκένωσης ημ-επιφάνειας
* IX-P Μπουζί ιριδίου MAX
* LPG 1-8 LaserLine σειρά μπουζί για βενζινομηχανές

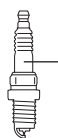

RE 7 C L

RE		7		C		-L	
Τύπος		Τιμή θερμότητας		Κατασκευή		Διάκενο ηλεκτροδίου	
RE	Μπουζί για περιστροφικούς κινητήρες	5	<p>θερμός τύπος</p> <p>ψυχροί τύποι</p>	A, B, C... Suffix code		-L	Μπροστινή πλευρά
SD	Μπουζί για περιστροφικούς κινητήρες (Διάκενο εκκένωσης ημ-επιφάνειας)	6				-T	Πλευρά σύνδεσης
		7					
		8					
		9					
		10					
		11					

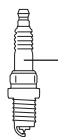

HB 6 A IX - 11 P

HB		6		A			IX		-11		P	
Τύπος		Τιμή θερμότητας		Διάμετρος σπειρώματος	Μήκος σπειρώματος	Διαμόρφωση θέσης	εξάγωνο			Διάκενο ηλεκτροδίου		
HB	HYBD (τριπλό ηλεκτρόδιο γείωσης υβριδικού τύπου)	4	<p>θερμός τύπος</p> <p>ψυχροί τύποι</p>	A	∅ 14,0	20,5	Στεγανοποιητικός δακτύλιος	Hex 16,0	IX	-8	0,8	
		5		B	∅ 14,0	19,0	Στεγανοποιητικός δακτύλιος	Hex 16,0		-9	0,9	
		6								-10	1,0	
		7								-11	1,1	
		8							-13	1,3		

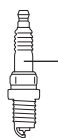

DF 6 H A

DF		6		H			-11		A	
Τύπος		Τιμή θερμότητας		Διάμετρος σπειρώματος	Μήκος σπειρώματος	Διαμόρφωση θέσης	εξάγωνο	Διάκενο ηλεκτροδίου		
DF	Μπουζί υψηλής αναφλεξιμότητας (Διπλά λεπτά ηλεκτρόδια)	4	<p>θερμός τύπος</p> <p>ψυχροί τύποι</p>	A	∅ 14,0	19,0	Στεγανοποιητικός δακτύλιος	Hex 16,0	-8	0,8
		5		B	∅ 14,0	26,5	Στεγανοποιητικός δακτύλιος	Hex 16,0	-9	0,9
DFH	Μπουζί υψηλής αναφλεξιμότητας (DF + Υβριδικού τύπου)	6		C	∅ 12,0	26,5	Στεγανοποιητικός δακτύλιος	Hex 14,0	-10	1,0
		7		* DF6H-11A : Μήκος σπειρώματος 28,0mm					-11	1,1
		8							-13	1,3
		9						-15	1,5	



Parça numaramızın okunma şekli: Ateşleme Bujileri

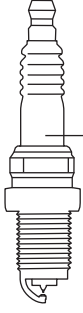

B P R 5 E S - 11

Birim: mm

B		P		R		5		E		S		-11					
	Diş çapı	altı köşeli	Yapı	Parazit giderme direnci		Isı değeri		Diş uzunluğu		Konstrüksiyon özellikleri		Elektrot mesafesi					
A	ø 18,0	Hex 25,4	P	R	Direnç	2		E	19,0	B	sabit SAE-bağlantı somunu (CR8EB)	boş	Motosiklet: 0,7-0,8				
B	ø 14,0	Hex 20,8	P	Z	indüktif direnç	4		EF	17,5	CM	Eğri şasi elektrodu	-	Araba: 0,8-0,9				
BC	ø 14,0	Hex 16,0	M			5		EH	19,0 yarım yapılmış		Kompakt tip (Açıktaki izolasyon uzunluğu: 18,5)						
BK	ø 14,0	Hex 16,0				6		H	12,7	CS	Eğri şasi elektrodu	-8	0,8				
C	ø 10,0	Hex 16,0	U			7		L	11,2	G,GV	Yarış bujisi	-9	0,9				
D	ø 12,0	Hex 18,0				8				I	İridiyum çekirdekli elektrot	-10	1,0				
DC	ø 12,0	Hex 16,0				9		boş	Konik sızdırmaz valf A(P)-F : 10,9 B(P)-F : 11,2 BM(P)-F : 7,8	IX	İridiyum buji	-11	1,1				
E	ø 8,0	Hex 13,0				10			Küçük tipte buji B(P)M- : 9,5 B-LM : 9,5 CM- : 9,5 CM-6 : 8,6 C-50 : 8,5	J	2 çıkıntılı şasi elektrodu	-13	1,3				
*İstisna B(P)M-A.Y : ø 14,0, Hex 19,0 P(P)-(E)F : ø 14,0, Hex 16,0 CM-6 : ø 10,0, Hex 14,0													K	2 şasi elektrodu	-15	1,5	
BC : Eski JIS standart boyut Conta devresinden terminal kontağına kadar uzunluk 53,0 mm'dir.													-LM	Kompakt tip (izolatör uzunluğu: 14,5mm)			
BK : ISO / JIS standart boyut Conta devresinden terminal kontağına kadar uzunluk 50,5 mm'dir.													N	özel toprak elektrodu	-S	özel conta	
													P	Platin elektrodu Tekli şasi elektrodu: Çift platinyum	-E	özel direnç	
														Çoklu şasi elektrodu: Tekli platinyum çekirdekli elektrot	IX-P	İridiyum MAKS buji	
													Q	4 şasi elektrodu	LPG 1-8	Gazlı motorda kullanılm için LaserLine kızdırma bujisi	
													S	Standart tip			
													T	3 şasi elektrodu			
													U	Yarış kayar kıvılcım tipi			
													Y	V-çentikli orta elektrot			
													Z	özel tasarım			



Jak odczytać numer części: Świece zapłonowe

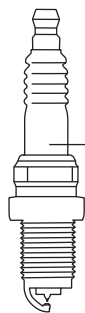

B P R 5 E S - 11

Jednostka:mm

B		P		R		5		E		S		-11				
	Średnica gwintu	rozwartość klucza sześciokątne	Struktura		Opornik przeciwzakłóceniuowy		Wartość cieplna		Długość gwintu		Właściwości konstrukcyjne		Odstęp elektrod			
A	∅ 18,0	Hex 25,4	P	Wysunięta końcówka izolatora	R	Opornik	2	<p>Ciepła</p> <p>Zimna</p>	E	19,0	B	Stala nakrętka SAE (CR8EB)	puste	Motocykl:		
B	∅ 14,0	Hex 20,8			Z	Oporność indukcyjna	4		5	EF	17,5	CM		Skośna elektroda, uziemiona Typ kompaktowy (długość otwartego izolatora: 18,5)	Samochód:	
BC	∅ 14,0	Hex 16,0	M	Świeca kompaktowa		6	6		H	12,7	CS	Skośna elektroda, uziemiona	-8	0,8		
BK	∅ 14,0	Hex 16,0				7	7		L	11,2	G,GV	Świece zapłonowe wysięgowe:	-9	0,9		
C	∅ 10,0	Hex 16,0	U	Iskra ślizgowa bądź półślizgowa		8	8		puste	Szczelne gniazdo stożkowe A(P)-F : 10,9 B(P)-F : 11,2 BM(P)-F : 7,8	I	Irydowa elektroda centralna	-10	1,0		
D	∅ 12,0	Hex 18,0				9	9				J	2 wystające elektrody, uziemione	-11	1,1		
DC	∅ 12,0	Hex 16,0	E	Hex 13,0		10	10		K	2 elektrody, uziemione	-13	1,3				
E	∅ 8,0	Hex 13,0				-LM	Typ kompaktowy (długość izolatora: 14,5mm)		-15	1,5						
*Wyjatek B(P)M-A,Y : ∅ 14,0, Hex 19,0 P(P)-(E)F : ∅ 14,0, Hex 16,0 CM-6 : ∅ 10,0, Hex 14,0 BC : Stary rozmiar wg normy JIS Długość od obwodu uszczelki do styku zacisku wynosi 53,0 mm. BK : Rozmiar wg normy ISO/JIS Długość od obwodu uszczelki do styku zacisku wynosi 50,5 mm.																
													N		Specjalna elektroda masowa	-S
												P		Elektroda platynowa Pojedyncza elektroda, uziemiona: Podwójna platynowa elektroda z wielokrotnym uziemieniem: Pojedyncza platynowa w elektrodzie centralnej:	-E	Specjalny opornik
												Q		4 elektrody, uziemione	IX-P	Świeca irydowa MAX
											S		Typ standardowy	LPG 1-8	Oferta świec zapłonowych LaserLine do silników benzynowych	
											T		3 elektrody, uziemione			
											U		Iskra półślizgowa			
											Y		Elektroda środkowa z nacięciem V			
											Z		Specjalna konstrukcja			



Jak odczytać numer części: Świece zapłonowe

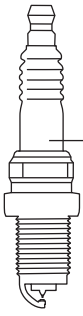

P F R 5 A - 11

Jednostka: mm

P		F				R		5		A		-11			
Typ świecy		Średnica gwintu	Długość gwintu	Konfiguracja gniazda	rozwartość klucza sześciokątnego	Opornik przeciwzakłóceńowy		Wartość cieplna		Konstrukcja		Odstęp elektrod			
DI	Wysoka zdolność zapłonu, Podwójne, cienkie elektrody	F	∅ 14,0	19,0	Pierścień uszczelniający	Hex 16,0	R	Opornik	2		A,B,C... kod przyrostka		leer	Motocykl: 0,7-0,8	
I	Elektroda centralna: Iryd Elektroda uziemiająca: Platyna	FE	∅ 14,0	19,0	Pierścień uszczelniający	Hex 16,0			4						Samochód: 0,8-0,9
L	Długi gwint	G	∅ 14,0	19,0	Pierścień uszczelniający	Hex 20,8			5					-7	0,7
P	Podwójna platynowa świeca zapłonowa	J	∅ 12,0	19,0	Pierścień uszczelniający	Hex 18,0			6					-9	0,9
S	Świeca o dużej zapłonowości: typ z wąską końcówką kwadratową	K	∅ 12,0	19,0	Pierścień uszczelniający	Hex 16,0			7			I	Irydowa elektroda centralna	-10	1,0
Z	Wysunięta końcówka z elektrodami	KA	∅ 12,0	19,0	Pierścień uszczelniający	Hex 14,0			8			IX	Elektroda irydowa - typ IX	-11	1,1
		KB	∅ 12,0	19,0	Pierścień uszczelniający	Bi-Hex 14,0 (Dwunastokątne *)			9			P	Platynowa elektroda centralna	-13	1,3
		KE	∅ 12,0	19,0	Pierścień uszczelniający	Hex 16,0			10					-15	1,5
		KF	∅ 12,0	19,0	Pierścień uszczelniający	Hex 14,0								-A	brak pierścienia uszczelniającego
		KG	∅ 12,0	19,0	Pierścień uszczelniający	Bi-Hex 14,0 (Dwunastokątne *)								-D	Metalowa osłona: powłoka niklowa
		L	∅ 10,0	12,7	Pierścień uszczelniający	Hex 16,0							-E	Specjalny opornik	
		M	∅ 10,0	19,0	Pierścień uszczelniający	Hex 16,0							-G	Elektroda z rdzeniem miedzianym, uziemiona	
		MA	∅ 10,0	19,0	Pierścień uszczelniający	Hex 14,0							-H	Gwint specjalny	
		MF	∅ 10,0	19,0	Pierścień uszczelniający	Hex 14,0							-J	2 elektrody masy	
		NA	∅ 12,0	17,5	Szczelne gniazdo stożkowe	Hex 14,0							-K	Elektroda odporna na wibracje, uziemiona	
		T	∅ 14,0	17,5	Szczelne gniazdo stożkowe	Hex 16,0							-N	Specjalna elektroda masy	
		U	∅ 14,0	11,2	Szczelne gniazdo stożkowe	Hex 16,0							-Q	4 elektrody masowe	
		W	∅ 18,0	10,9	Szczelne gniazdo stożkowe	Hex 20,8							-S	Specjalny pierścień uszczelniający	
		X	∅ 14,0	9,5	Pierścień uszczelniający	Hex 20,8							-T	3 elektrody masy	
		Y	∅ 14,0	11,2	Szczelne gniazdo stożkowe	Hex 16,0							-U	Półpowierzchniowy rodzaj wyładowania	
													IX-P	Świeca irydowa MAX	
													LPG 1-8	Oferta świec zapłonowych LaserLine do silników benzynowych	



RE 7 C - L

RE		7		C		-L	
Typ świecy		Wartość cieplna		Konstrukcja		Odstęp elektrod	
RE	Świeca do silników rotacyjnych	5		A,B,C... kod przyrostka		-L Dolna strona	
SD	Świeca do silników rotacyjnych (przerwa wyładowania półpowierzchniowego)	6				-T Górna strona	
		7					
		8					
		9					
		10					
		11					



HB 6 A IX - 11 P

HB		6		A		IX		-11		P		
Typ świecy		Wartość cieplna		Średnica gwintu	Długość gwintu	Konfiguracja gniazda	rozwartość klucza sześciokątnego	Odstęp elektrod				
HB	HYBD (typ hybrydowy z 3 elektrodami uziemionymi)	4		A	∅ 14,0	20,5	Pierścień uszczelniający	Hex 16,0	IX	-8	0,8	
		5			B	∅ 14,0	19,0	Pierścień uszczelniający	Hex 16,0		-9	0,9
		6									-10	1,0
		7									-11	1,1
		8								-13	1,3	



DF 6 H - 11 A

DF		6		H		-11		A			
Typ świecy		Wartość cieplna		Średnica gwintu	Długość gwintu	Konfiguracja gniazda	Sechskant	Odstęp elektrod			
DF	Świeca o dużej zapłonowości (podwójne, cienkie elektrody)	4		A	∅ 14,0	19,0	Pierścień uszczelniający	Hex 16,0	-8	0,8	
		5			B	∅ 14,0	26,5	Pierścień uszczelniający	Hex 16,0	-9	0,9
DFH	Świeca o dużej zapłonowości (Typ DF + hybrydowy)	6			C	∅ 12,0	26,5	Pierścień uszczelniający	Hex 14,0	-10	1,0
		7			*DF6H-11A : Długość gwintu 28,0mm				-11	1,1	
		8							-13	1,3	
		9						-15	1,5		



Jak číst naše číslo dílu: Zapalovací svíčky

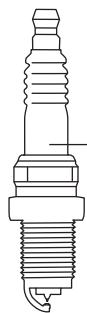

B P R 5 E S - 11

Jednotky: mm

B		P		R		5		E		S		-11		
	Průměr	šestihran	Struktura	Odušovací odpor		Tepelná hodnota		Délka závitu		Konstrukční vlastnosti		Vzdálenost elektrod		
A	ø 18,0	Hex 25,4	P	předsunutá špička izolátoru	R	Odpor	2	teplé typy studené typy	E	19,0	B	pevná přípojná matice SAE (CR8EB)	prázdné	Motorcykl : 0,7-0,8
B	ø 14,0	Hex 20,8			Z	Induktivní odpor	4		EF	17,5	CM	Šikmé provedení zemnicí elektrody Kompaktní typ (Délka izolátoru: 18,5)		Auto : 0,8-0,9
BC	ø 14,0	Hex 16,0	M	Kompaktní svíčka			5		EH	19,0 provedení do poloviny			-8	0,8
BK	ø 14,0	Hex 16,0					6		H	12,7	CS	Šikmé provedení zemnicí elektrody	-9	0,9
C	ø 10,0	Hex 16,0	U	Typ s klouzavou jiskrou nebo přidavnou dráhou jiskry			7		L	11,2	G,GV	Závodní zapalovací svíčka	-10	1,0
D	ø 12,0	Hex 18,0					8				I	Iridiová centrální elektroda	-11	1,1
DC	ø 12,0	Hex 16,0					9		prázdné	Kuželové těsnící sedlo A(P)-F : 10,9 B(P)-F : 11,2 BM(P)-F : 7,8	IX	Iridiová zapalovací svíčka	-13	1,3
E	ø 8,0	Hex 13,0					10			Malý typ svíčky B(P)M- : 9,5 B-LM : 9,5 CM- : 9,5 CM-6 : 8,6 C-50 : 8,5	J	2 zemnicí elektrody (speciální tvar)	-15	1,5
* Výminka B(P)M-A,Y : ø 14,0, Hex 19,0 P(P)-(E)F : ø 14,0, Hex 16,0 CM-6 : ø 10,0, Hex 14,0 BC : Stará standardní velikost JIS Délka od kroužku těsnění ke koncovému kontaktu je 53,0 mm. BK : Standardní velikost ISO/JIS Délka od kroužku těsnění ke koncovému kontaktu je 50,5 mm.														
												-LM	Kompaktní typy (délka izolátoru: 14,5mm)	-S
											N	speciální zemnicí elektroda	-E	speciální odpor
											P	Platinová elektroda 1 zemnicí elektroda: Dvojitá platinová Více zemnicích elektrod: Jedna platinová ve střední elektrodě	IX-P	Iridiová svíčka MAX
											Q	4 zemnicí elektrody	LPG 1-8	Zapalovací svíčka LaserLine s prodlouženým dosahem pro benzínové motory
											S	Standardní typy		
											T	3 zemnicí elektrody		
											U	Typ s poloviční klouzavou jiskrou		
											Y	Střední elektroda se zářezem V		
											Z	speciální konstrukce		



Jak číst naše číslo dílu: Zapalovací svíčky

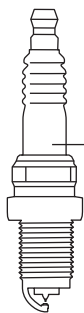

P F R 5 A - 11

Jednotky: mm

P		F				R		5		A		-11			
Zapalovací typ		Průměr	Délka závitů	Nastavení objímky	šestihran	Odrušovací odpor		Teplotná hodnota		Konstrukce		Vzdálenost elektrod			
DI	mimořádně vysoká schopnost zapálení, dvojitě provedené, jemné elektrody	F	ø 14,0	19,0	Těsnící kroužek	Hex 16,0	R	Odpor	2	 teplé typy studené typy	A,B,C... kód přípony		prázdné	Motocykl: 0,7-0,8 Auto: 0,8-0,9	
I	Hlavní elektroda: Iridium Zemnicí elektroda: Platina	FE	ø 14,0	19,0	Těsnící kroužek	Hex 16,0			4				-7	0,7	
L	mimořádně dlouhý závit	G	ø 14,0	19,0	Těsnící kroužek	Hex 20,8			5				-9	0,9	
P	Dvojitá platinová zapalovací svíčka	J	ø 12,0	19,0	Těsnící kroužek	Hex 18,0			6			I Iridiová centrální elektroda	-10	1,0	
S	Svíčka s mimořádně vysokou schopností zapálení: čtvercový platinový čip	K	ø 12,0	19,0	Těsnící kroužek	Hex 16,0			7				-11	1,1	
Z	Předsunutá jiskřiště	KA	ø 12,0	19,0	Těsnící kroužek	Hex 14,0			8			IX Iridiová zapalovací svíčka	-13	1,3	
		KB	ø 12,0	19,0	Těsnící kroužek	Bi-Hex 14,0 (Dvojitý šestihřanný *)			9				P	Platinová centrální elektroda	-15
	Výše uvedená označení se mohou vyskytovat kombinovaně, <Příklad>ILFR--, PLZFR--, pokud je v kódu „L“, pro mimořádně dlouhý závit stojí „L“ před všemi ostatními písmeny délkového označení. <Příklad> *svíčka s těsnícím kroužkem FR5AP : délka závitů 19,0mm ↓ LFR5AP-11 : délka závitů 26,5mm *svíčka s kuželovým těsnícím sedlem PTR5C-13 : délka závitů 17,5mm ↓ PLTR6A-10G : délka závitů 25,0mm	KG	ø 12,0	19,0	Těsnící kroužek	Bi-Hex 14,0 (Dvojitý šestihřanný *)			10			* Pokud je „I“ nebo „P“ na začátku číselné řady („I“ nebo „P“ po teplotném výkonu znamenají kód přípony). <Příklad> IZFR6P8 je iridiová svíčka I: Iridium P: Kód přípony * <Výjimka> ZFR0P-H je niklová svíčka		-A	bez těsnícího kroužku
		L	ø 10,0	12,7	Těsnící kroužek	Hex 16,0							-D	Kovový plášť: poniklováno	
		M	ø 10,0	19,0	Těsnící kroužek	Hex 16,0							-E	speciální odpor	
		MA	ø 10,0	19,0	Těsnící kroužek	Hex 14,0						-G	Zemnicí elektroda s měděným jádrem		
		MF	ø 10,0	19,0	Těsnící kroužek	Hex 14,0						-H	speciální závit		
		NA	ø 12,0	17,5	Kuželové těsnící sedlo	Hex 14,0						-J	2 zemnicí elektrody		
		T	ø 14,0	17,5	Kuželové těsnící sedlo	Hex 16,0						-K	Zemnicí elektroda chráněná proti vibracím		
		U	ø 14,0	11,2	Kuželové těsnící sedlo	Hex 16,0						-N	speciální zemnicí elektroda		
		W	ø 18,0	10,9	Kuželové těsnící sedlo	Hex 20,8						-Q	4 zemnicí elektrody		
		X	ø 14,0	9,5	Těsnící kroužek	Hex 20,8						-S	speciální těsnící kroužek		
		Y	ø 14,0	11,2	Kuželové těsnící sedlo	Hex 16,0						-T	3 zemnicí elektrody		
						Dvojitý šestihřanný						-U	Typ s poloviční klouzavou jiskrou		
						šestihřanný						IX-P	Iridiová svíčka MAX		
												LPG I-8	Zapalovací svíčka LaserLine s prodlouženým dosahem pro benzinové motory		

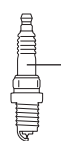

RE 7 C - L

RE		7		C		-L	
Zapalovací typ		Teplotná hodnota		Konstrukce		Vzdálenost elektrod	
RE	Svíčka pro rotační motory	5	 teplé typy studené typy	A,B,C... kód přípony		-L	Strana předstihu
SD	Svíčka pro rotační motory (Poloviční s klouzavou jiskrou)	6				-T	Pracovní strana
		7					
		8					
		9					
		10					
		11					

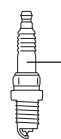

HB 6 A IX - 11 P

HB		6		A			IX		-11		P	
Zapalovací typ		Teplotná hodnota		Průměr	Délka závitů	Nastavení objímky	šestihran	Vzdálenost elektrod				
HB	HYBD (hybridní typ s 3 zemnicími elektrodami)	4	 teplé typy studené typy	A	ø 14,0	20,5	Těsnící kroužek	Hex 16,0	IX	-8	0,8	
		5		B	ø 14,0	19,0	Těsnící kroužek	Hex 16,0		-9	0,9	
		6								-10	1,0	
		7								-11	1,1	
		8							-13	1,3		

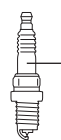

DF 6 H - 11 A

DF		6		H			-11		A		
Zapalovací typ		Teplotná hodnota		Průměr	Délka závitů	Nastavení objímky	šestihran	Vzdálenost elektrod			
DF	Svíčka s mimořádně vysokou schopností zapálení (Dvojitá přesná elektroda)	4	 teplé typy studené typy	A	ø 14,0	19,0	Těsnící kroužek	Hex 16,0	-8	0,8	A,B,C... kód přípony
		5		B	ø 14,0	26,5	Těsnící kroužek	Hex 16,0	-9	0,9	
DFH	Svíčka s mimořádně vysokou schopností zapálení (DF + hybridní typ)	6		C	ø 12,0	26,5	Těsnící kroužek	Hex 14,0	-10	1,0	
		7		*DF6H-11A : Délka závitů 28,0mm					-11	1,1	
		8							-13	1,3	
		9						-15	1,5		



Hogyan kell leolvasni a cikkszámot: Gyújtógyertyák

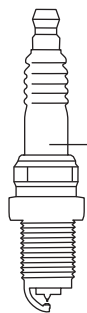

B P R 5 E S - 11

Egység: mm

B		P		R		5		E		S		-11		
Menet átmérő	hatlap	Struktúra	Zavarszűrő ellenállás	Hőérték	Menethossz	Konstrukciós jellemzők		Elektrodahézag						
A	∅ 18,0	Hex 25,4	P	előretölt szigetelőcsúcs	R	Ellenállás	2	<p>meleg típus</p> <p>hideg típus</p>	E	19,0	B	rögzített SAE csatlakozó anyja (CR8EB)	üres	Motorerékpár: 0,7-0,8
B	∅ 14,0	Hex 20,8	Z	induktív ellenállás	4		EF		17,5	CM	Ferde testelektróda	Kompakt kivétel (Kített szigetelés hossz: 18,5)		Autó: 0,8-0,9
BC	∅ 14,0	Hex 16,0	M	Kompakt gyertya	5		EH		19,0 félig kivezetett	CS	Ferde testelektróda		-8	0,8
BK	∅ 14,0	Hex 16,0	U	Síklószikrás típus vagy kiegészítő szikraút	6		H		12,7	G,GV	Versenygyertya		-9	0,9
C	∅ 10,0	Hex 16,0			7		L		11,2	I	Írídium középelektróda		-10	1,0
D	∅ 12,0	Hex 18,0			8		üres		Kúpos tömítő ülék A(P)-F : 10,9 B(P)-F : 11,2 BM(P)-F : 7,8	IX	Írídium gyújtógyertya		-11	1,1
DC	∅ 12,0	Hex 16,0			9				Kis dugó típus B(P)M- : 9,5 B-LM : 9,5 CM- : 9,5 CM-6 : 8,6 C-50 : 8,5	J	2 vetített testelektróda		-13	1,3
E	∅ 8,0	Hex 13,0			10					K	2 testelektróda		-15	1,5
* Kivétel B(P)M-A.Y : ∅ 14,0, Hex 19,0 P(P)-(E)F : ∅ 14,0, Hex 16,0 CM-6 : ∅ 10,0, Hex 14,0										-LM	Kompakt típus (szigetelőhossz: 14,5 mm)		-S	speciális tömítőgyűrű
BC : Régi JIS szabvány méret A tömítés és a csatlakozás közötti távolság 53,0mm.										P	platina elektróda Egyetlen platina Dupla platina		-E	speciális ellenállás
BK : ISO / JIS szabvány méret A tömítés és a csatlakozás közötti távolság 50,5mm.										Multi testelektróda: Egyetlen platina középelektródában		IX-P	Írídium MAX gyertya	
									Q	4 testelektróda		LPG 1-8	Laserline gyújtógyertya tartomány gázmotor használatra	
									S	Normál típus				
									T	3 testelektróda				
									U	Félg síklószikrás típus				
									Y	középelektróda V horonnyal				
									Z	speciális kialakítás				



Hogyan kell leolvasni a cikkszámot: Gyújtógyertyák

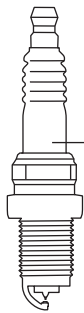

Egység: mm

P		F				R		5		A		-11			
Gyertyatípus		Menet átmérő	Menethossz	Fenek konfiguráció	hatlap	Zavarszűrő ellenállás		Hőérték		Konstrukció		Elektrodahézag			
DI	különösen magas gyújtóképesség, duplán kivezetett, finom elektrodák	F	∅ 14,0	19,0	Tömítés	Hex 16,0	R	Ellenállás	2	meleg típus	A,B,C... Suffix code		üres	Motorkerékpár: 0,7-0,8 Autó: 0,8-0,9	
I	Központi elektróda: Iridium Földelő elektróda: Platinium	FE	∅ 14,0	19,0	Tömítés	Hex 16,0			4				-7	0,7	
		G	∅ 14,0	19,0	Tömítés	Hex 20,8			5					-9	0,9
		J	∅ 12,0	19,0	Tömítés	Hex 18,0			6						
		K	∅ 12,0	19,0	Tömítés	Hex 16,0			7			I	Iridium közepeléktroda	-10	1,0
L	különösen hosszú menet	KA	∅ 12,0	19,0	Tömítés	Hex 14,0			8			IX	iridium gyújtógyertya	-13	1,3
P	Dupla paltina gyújtógyertya	KB	∅ 12,0	19,0	Tömítés	Bi-Hex 14,0 (Kettős hatszögletű *)			9			P	Platina közepeléktroda	-15	1,5
S	Magas hőértékű gyertya: vékony négyzetes hegy típus	KE	∅ 12,0	19,0	Tömítés	Hex 16,0			10		hideg típus				
Z	Tervezett gyújtógyertya vég	KF	∅ 12,0	19,0	Tömítés	Hex 14,0						* Ha az alkatrész szám előtt áll egy „I” vagy egy „P” (az „I” vagy a „P” a hőszabályozás suffix kódjává válnak).		-A	nincs tömítőgyűrű
	A fent felsorolt jelölések kombinációként is előfordulhatnak, <Példa>ILFR-..., PLZFR-..., Amikor „L” szerepel, prioritást kap az „L” (hosszú menet) a menethosszban. <Példa> *gyertya tömítéssel FR5AP : menethossz 19,0mm ↓ LFR5AP-11 : menethossz 26,5mm *gyertya kúpos tömítő üléssel PTR5C-13 : menethossz 17,5mm ↓ PLTR6A-10G : menethossz 25,0mm	KG	∅ 12,0	19,0	Tömítés	Bi-Hex 14,0 (Kettős hatszögletű *)						<Példa> Az IZFR6P8 egy iridium gyújtógyertya I : Iridium P : Suffix kód * <Kivétel> A ZFR0P-G egy nikkel gyújtógyertya		-D	Fém persely: galvanizált
		L	∅ 10,0	12,7	Tömítés	Hex 16,0								-E	speciális ellenállás
		M	∅ 10,0	19,0	Tömítés	Hex 16,0							-G	Rézmagos testelektroda	
		MA	∅ 10,0	19,0	Tömítés	Hex 14,0							-H	speciális menet	
		MF	∅ 10,0	19,0	Tömítés	Hex 14,0							-J	2 testelektroda	
		NA	∅ 12,0	17,5	Kúpos tömítő ülék	Hex 14,0							-K	Testelektroda rezgéssel szembeni ellenállása	
		T	∅ 14,0	17,5	Kúpos tömítő ülék	Hex 16,0							-N	speciális testelektroda	
		U	∅ 14,0	11,2	Kúpos tömítő ülék	Hex 16,0							-Q	4 testelektroda	
		W	∅ 18,0	10,9	Kúpos tömítő ülék	Hex 20,8							-S	speciális tömítőgyűrű	
		X	∅ 14,0	9,5	Tömítés	Hex 20,8							-T	3 testelektroda	
	Y	∅ 14,0	11,2	Kúpos tömítő ülék	Hex 16,0							-U	Fél kúpszószikrás típus		
		* Kivétel TR5A-10, TR5A-13, TR5B-13, TR6B-10, TR6B-13, PTR5A-10, PTR5A-13 : Menethossz 25,0mm											IX-P	Iridium MAX gyertya	
		** Kettős hatszögletű aljzat szükséges.											LPG 1-8	Laserline gyújtógyertya tartomány gázmotor használatra	
		*FE, KE, KF, KG, MF : Hosszabban kített szigetelés hossz típus													



RE		7		C		-L	
Gyertyatípus		Hőérték		Konstrukció		Elektrodahézag	
RE	Forgódugattyús motor gyertya	5	meleg típus	A,B,C... Suffix code		-L	Leading oldal
SD	Forgódugattyús motor gyertya (Fél kúpszószikrás hézag)	6				-T	Trading oldal
		7					
		8					
		9					
		10					
		11	hideg típus				

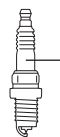

HB		6		A				IX	-11		P	
Gyertyatípus		Hőérték		Menet átmérő	Menethossz	Fenek konfiguráció	hatlap		Elektrodahézag			
HB	HYBD (3 testelektroda hibrid típus)	4	meleg típus	A	∅ 14,0	20,5	Tömítés	Hex 16,0	IX	-8	0,8	
		5		B	∅ 14,0	19,0	Tömítés	Hex 16,0		-9	0,9	
		6								-10	1,0	
		7								-11	1,1	
		8		hideg típus						-13	1,3	

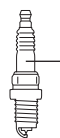

DF		6		H				-11		A		
Gyertyatípus		Hőérték		Menet átmérő	Menethossz	Fenek konfiguráció	hatlap	Elektrodahézag				
DF	Nagy hőértékű gyertya (dupla finom elektrodák)	4	meleg típus	A	∅ 14,0	19,0	Tömítés	Hex 16,0	-8	0,8	A,B,C... Suffix code	
DFH	Nagy hőértékű gyertya (DF + hibrid típus)	5		B	∅ 14,0	26,5	Tömítés	Hex 16,0	-9	0,9		
		6			C	∅ 12,0	26,5	Tömítés	Hex 14,0	-10	1,0	
		7			*DF6H-11A : Menethossz 28,0mm					-11	1,1	
		8								-13	1,3	
		9		hideg típus						-15	1,5	



Что означает код детали: Свечи накаливания

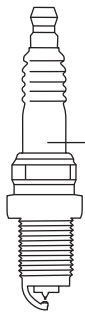

Единица измерения : мм

B		P		R		5		E		S		-11		
Диаметр резьбы	Шестигранник	Структура		Помехоподавляющий резистор		Калильное число		Длина резьбы		Конструктивные особенности		Межэлектродный зазор		
A	∅ 18,0	Hex 25,4	P	с выступающим изолятором	R	с резистором	2		E	19,0	B	Неподвижная контактная гайка SAE (CR8EB)		
B	∅ 14,0	Hex 20,8	Z	с индуктивным резистором	4	EF	17,5		CM	Наклонный боковой электрод Компактный тип (длина выступающего изолятора: 18,5)		leer	Мотоцикл: 0,7-0,8	
BC	∅ 14,0	Hex 16,0	M	Компактная свеча	6	EH	19,0 с частично нарезанной резьбой, длина резьбы 12,7мм		CS	Наклонный боковой электрод		-8	Автомобиль: 0,8-0,9	
BK	∅ 14,0	Hex 16,0	U	Тип с поверхностным разрядом или дополнительным искровым зазором	7	H	12,7		G,GV	Гоночная свеча зажигания		-9	0,8	
C	∅ 10,0	Hex 16,0			8	I	Иридиевый центральный электрод		I	Иридиевый центральный электрод		-10	0,9	
D	∅ 12,0	Hex 18,0			9	L	11,2		IX	Иридиевый электрод (IX)		-11	1,1	
DC	∅ 12,0	Hex 16,0			10	пустой	Коническая плотная посадка A(P)-F : 10,9 B(P)-F : 11,2 BM(P)-F : 7,8		J	2 удлиненных боковых электрода		-13	1,3	
E	∅ 8,0	Hex 13,0					Компактная свеча B(P)M- : 9,5 B-LM : 9,5 CM- : 9,5 CM-6 : 8,6 C-50 : 8,5		K	2 боковых электрода		-15	1,5	
*Исключения B(P)M-A,Y : ∅ 14,0, Hex 19,0 R(P)-(E)F : ∅ 14,0, Hex 16,0 CM-6 : ∅ 10,0, Hex 14,0										-LM	Компактный тип (Длина изолятора: 14,5 мм)		-S	Специальное уплотнительное кольцо
BC : Устаревший размер по японским промышленным стандартам JIS Расстояние от уплотняющей прокладки до контактного вывода составляет 53,0 мм.										P	Платиновый электрод Один боковой электрод : двойной платиновый Несколько боковых электродов: Одинарный платиновый центральный электрод		-E	Специальное сопротивление
BK : Стандартный размер ISO/JIS Расстояние от уплотняющей прокладки до контактного вывода составляет 50,5 мм.									Q	4 боковых электрода		IX-P	Свеча Iridium MAX	
									S	Стандартный тип		LPG 1-8	Свеча зажигания LaserLine для использования в газовых двигателях	
									T	3 боковых электрода				
									U	Тип с полуповерхностным разрядом				
									Y	Центральный электрод с V-образной насечкой				
									Z	Специальная конструкция				



Что означает код детали: Свечи накаливания



P F R 5 A - 11

Единица измерения : мм

P		F				R	5		A		-11				
Типы свечей зажигания		Диаметр резьбы	Длина резьбы	Тип основания	Длина резьбы	Помехоподавляющий резистор	Калильное число		Конструкция		Межэлектродный зазор				
DI	Свеча с повышенной надёжностью зажигания, с особо тонким электродом	F	∅ 14,0	19,0	Уплотнительное кольцо	R		горячие	A, B, C...	пустой	Мотоцикл: 0,7-0,8				
I	Центральный электрод: иридий Боковой электрод: платина	FE	∅ 14,0	19,0	Уплотнительное кольцо				4					Автомобиль: 0,8-0,9	
L	Удлиненная резьбовая часть	G	∅ 14,0	19,0	Уплотнительное кольцо				5					-7	0,7
P	Двойная платиновая свеча зажигания	J	∅ 12,0	19,0	Уплотнительное кольцо				6					-9	0,9
S	Свеча с повышенной надёжностью зажигания : тонкая квадратная платиновая вставка	K	∅ 12,0	19,0	Уплотнительное кольцо				7			I	Иридиевый центральный электрод	-10	1,0
Z	выступающий запальный конец	KA	∅ 12,0	19,0	Уплотнительное кольцо				8			IX	Иридиевый электрод (IX)	-11	1,1
		KB	∅ 12,0	19,0	Уплотнительное кольцо				9			P	Платиновый центральный электрод	-15	1,5
		KE	∅ 12,0	19,0	Уплотнительное кольцо				10		холодные				
		KF	∅ 12,0	19,0	Уплотнительное кольцо										
		KG	∅ 12,0	19,0	Уплотнительное кольцо										
	Указанные выше обозначения могут быть комбинированными, <Пример>ILFR..., PLZFR..., При наличии индекса «L», приоритетным в определении длины резьбы является индекс «L» (длинная резьбовая часть). <Пример> * Свеча с уплотнительным кольцом FR5AP : длина резьбы 19,0мм ↓ LFR5AP-11 : длина резьбы 26,5мм * Свеча с конической плотной посадкой PTR5C-13 : длина резьбы 17,5мм ↓ PLTR6A-10G : длина резьбы 25,0мм	L	∅ 10,0	12,7	Уплотнительное кольцо						-A	без уплотнительного кольца			
		M	∅ 10,0	19,0	Уплотнительное кольцо						-D	Никелевое покрытие металлического корпуса			
		MA	∅ 10,0	19,0	Уплотнительное кольцо						-E	Специальное сопротивление			
		MF	∅ 10,0	19,0	Уплотнительное кольцо						-G	Боковой электрод с медным сердечником			
		NA	∅ 12,0	17,5	Коническая плотная посадка						-H	Специальная резьба			
		T	∅ 14,0	17,5	Коническая плотная посадка						-J	2 боковых электрода			
		U	∅ 14,0	11,2	Коническая плотная посадка						-K	Вибростойкий боковой электрод			
		W	∅ 18,0	10,9	Коническая плотная посадка						-N	Специальный боковой электрод			
		X	∅ 14,0	9,5	Уплотнительное кольцо						-Q	4 боковых электрода			
		Y	∅ 14,0	11,2	Коническая плотная посадка						-S	Специальное уплотнительное кольцо			
											-T	3 боковых электрода			
											-U	Тип с полупервоверхностным разрядом			
											IX-P	Свеча Iridium MAX			
											LPG 1-8	Свечи зажигания LaserLine для газовых двигателей for gas engines			

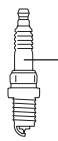

RE 7 C - L

RE		7		C		-L	
Типы свечей зажигания		Калильное число		Конструкция		Межэлектродный зазор	
RE	Свеча для роторных двигателей	5		A, B, C... Suffix код		-L Ведущая сторона	
SD	Свеча для роторных двигателей (полупервоверхностный разряд и дополнительный зазор)	6				-T Ведомая сторона	
		7					
		8					
		9					
		10					
		11					

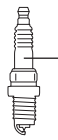

NB 6 A IX - 11 P

NB		6		A			IX	-11		P
Типы свечей зажигания		Калильное число		Диаметр резьбы	Длина резьбы	Тип основания	Шестигранник	Межэлектродный зазор		
NB	HYBD (гибридный тип с 3 боковыми электродами)	4		A	∅ 14,0	20,5	Уплотнительное кольцо	Hex 16,0	IX	-8 0,8
		5		B	∅ 14,0	19,0	Уплотнительное кольцо	Hex 16,0		-9 0,9
		6								-10 1,0
		7								-11 1,1
		8	холодные							-13 1,3

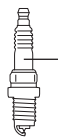

DF 6 H - 11 A

DF		6		H			-11		A		
Типы свечей зажигания		Калильное число		Диаметр резьбы	Длина резьбы	Тип основания	Шестигранник	Межэлектродный зазор			
DF	Свеча с повышенной надёжностью зажигания (двойные тонкие электроды)	4		A	∅ 14,0	19,0	Уплотнительное кольцо	Hex 16,0	-8 0,8	A, B, C... Suffix код	
		5		B	∅ 14,0	26,5	Уплотнительное кольцо	Hex 16,0	-9 0,9		
DFH	Свеча с повышенной надёжностью зажигания (DF + гибридный тип)	6			C	∅ 12,0	26,5	Уплотнительное кольцо	Hex 14,0	-10 1,0	
		7			*DF6H-11A : Длина резьбы 28,0mm						-11 1,1
		8		холодные							-13 1,3
		9								-15 1,5	



How to read our part number: Metal Glow Plugs



Y - **2** **0** **4** **T** **S** **1**

Unit : mm

Y		-2		0		4		T		S		1		
	Model / Type	Thread size		Battery Voltage		Serial Number		Heating Characteristics		Glow tube material		Modification no.		
Y/YS	Sheathed type	1	10 mm	0-4	12 V	this figure is the serial number		A	AQGS type	S	Special			
YD	Sheathed, with double insulators	2	12 mm	5-9	24 V			J	SRM type	None	Standard			
		3	10 mm					K or no letter	Standard type					
		4	14 mm					R, M, U	QGS type					
		5	10 mm					T, V	Fast heating type					
		6	10 mm					Note: Y-7XXR, Y-9XXR are SRM Types						
		7	10 mm					Declaration						
		8	18 mm					AQGS Advanced Quick Glow System						
		9	12 mm					SRM Self Regulating Metal Glow Plug						
		*Y-109, Y-159 and Y-171 for Caterpillar Mitsubishi have a thread size of 3/8" (~9.5mm).						QGS Quick Glow System						



Y **1** **001** **A** **S** **1**

Unit : mm

Y		1		001		A		S		1	
	Model / Type	Thread size		Serial Number / Battery Voltage		Heating Characteristics		Glow tube material		Modification no.	
Y	Sheathed type	1	10 mm	001-899	12 V	A	AQGS type	S	Special		
		2	12 mm	900-999	24 V	J	SRM type	None	Standard		
		4	14 mm					K or no letter	Standard type		
		8	8 mm					R, M, U	QGS type		
		9	9 mm					T, V	Fast heating type		
						Declaration					
						AQGS Advanced Quick Glow System					
						SRM Self Regulating Metal Glow Plug					
						QGS Quick Glow System					



How to read our part number: Metal Glow Plugs

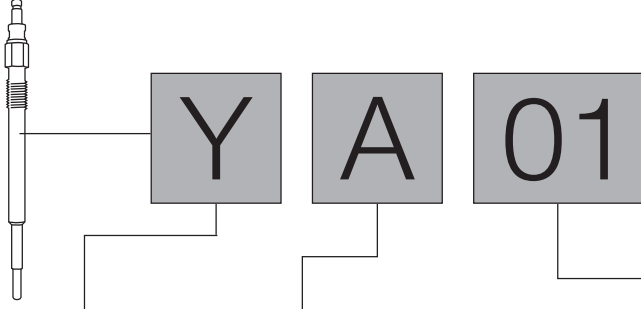

Unit : mm

Y	A	01
Model / Type	Heating Characteristics	Serial Number
Sheathed type Thread size: 8mm or 9mm	A Standard type	
	E QGS type or SRM type	

How to read our part number: Ceramic Glow Plugs

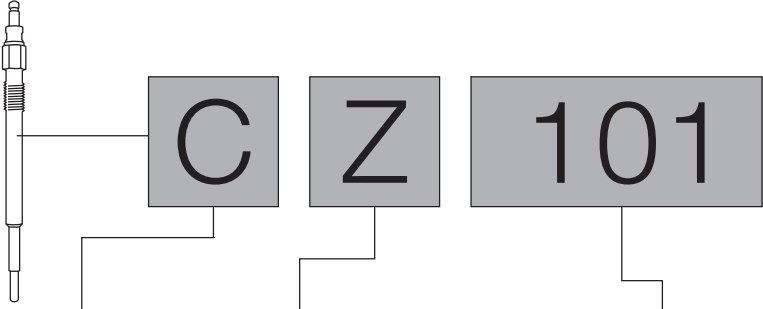

Unit : mm

C	Z	101
Model / Type	Heating Characteristics	Serial Number
Ceramic Glow Plug	X QGS Type Quick Glow System	
	Y SRC Type / HTC Self Regulating Ceramic Glow Plug	
	Z NHTC Type Quick Glow System	

Notes about the table

- △ = only for automobiles with immobilizer
- ◆ = only for automobiles without immobilizer

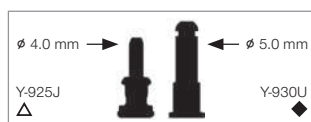

So lesen Sie unsere Teilenummer: Metall-Glühkerzen

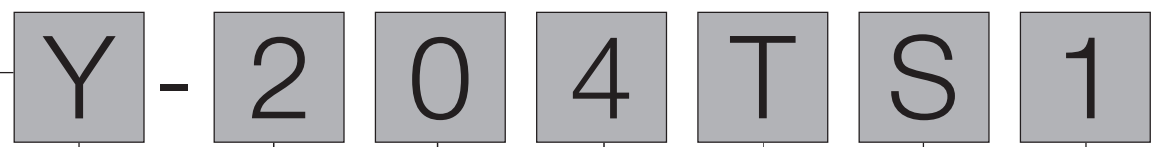

Einheit: mm

Y		-2		0		4		T		S		1	
	Ausführung / Type	Gewindedurchmesser		Batteriespannung		Seriennummer		Glühcharakteristik		Glühstabmaterial		Modifikationsnummer	
Y/YS	Stabglühkerze	1	10 mm	0-4	12 V	Diese Ziffer ist die Seriennummer		A	AQGS Type	S	Spezial		
YD	Stabglühkerze mit doppeltem Isolato	2	12 mm	5-9	24 V			J	SRM Type	Keine	Standard		
		3	10 mm					K oder kein Buchstabe		Standard Type			
		4	14 mm					R, M, U		QGS Type			
		5	10 mm					T, V		Schnellstart Type			
		6	10 mm					Hinweis: Y-7XXR, Y-9XXR sind SRM Typen					
		7	10 mm					Erklärung					
		8	18 mm					AQGS Advanced Quick Glow System (Weiterentwickelte Schnellstartglühkerze)					
		9	12 mm					SRM Self Regulating metal Glow Plug (selbstregulierende Metall-Glühkerze)					
		*Y-109, Y-159, Y-171 für Caterpillar / Mitsubishi haben einen Gewindedurchmesser von 3/8" (ca. 9.5 mm)						QGS Quick Glow System (Schnellstartglühkerze)					



Einheit: mm

Y		1		001		A		S		1	
	Ausführung / Type	Gewindedurchmesser		Seriennummer / Batteriespannung		Glühcharakteristik		Glühstabmaterial		Modifikationsnummer	
Y	Stabglühkerze	1	10 mm	001-899	12 V	A	AQGS Type	S	Spezial		
		2	12 mm	900-999	24 V	J	SRM Type	Keine	Standard		
		4	14 mm			K oder kein Buchstabe		Standard Type			
		8	8 mm			R, M, U		QGS Type			
		9	9 mm			T, V		Schnellstart Type			
						Erklärung					
						AQGS Advanced Quick Glow System (Weiterentwickelte Schnellstartglühkerze)					
						SRM Self Regulating metal Glow Plug (selbstregulierende Metall-Glühkerze)					
						QGS Quick Glow System (Schnellstartglühkerze)					



So lesen Sie unsere Teilenummer: Metall-Glühkerzen

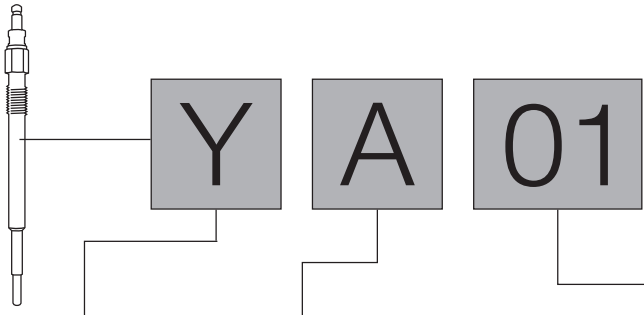

Einheit: mm

Y	A	01
Ausführung / Type	Glühcharakteristik	Seriennummer
Stabglühkerze Gewindedurchmesser: 8 mm oder 9 mm	A Standard Type	
	E QGS Type oder SRM Type	

So lesen Sie unsere Teilenummer: Keramik-Glühkerzen

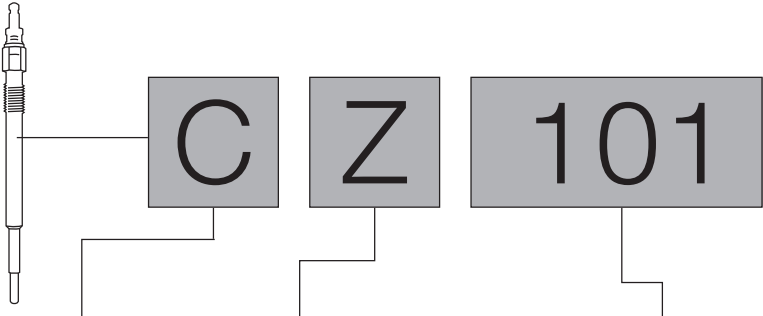

Einheit: mm

C	Z	101
Ausführung / Type	Glühcharakteristik	Seriennummer
Keramikglühkerze	X QGS Type Quick Glow System (Schnellglühsystem)	
	Y SRC Type / HTC Self Regulating Ceramic Glow Plug (selbstregulierende Keramik-Glühkerze)	
	Z NHTC Type Quick Glow System (Schnellglühsystem)	

Anmerkungen zur Tabelle

- △ = nur für Fahrzeuge mit Wegfahrsperre
- ◆ = nur für Fahrzeuge ohne Wegfahrsperre

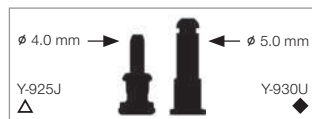

Comment lire notre numéro de pièce:

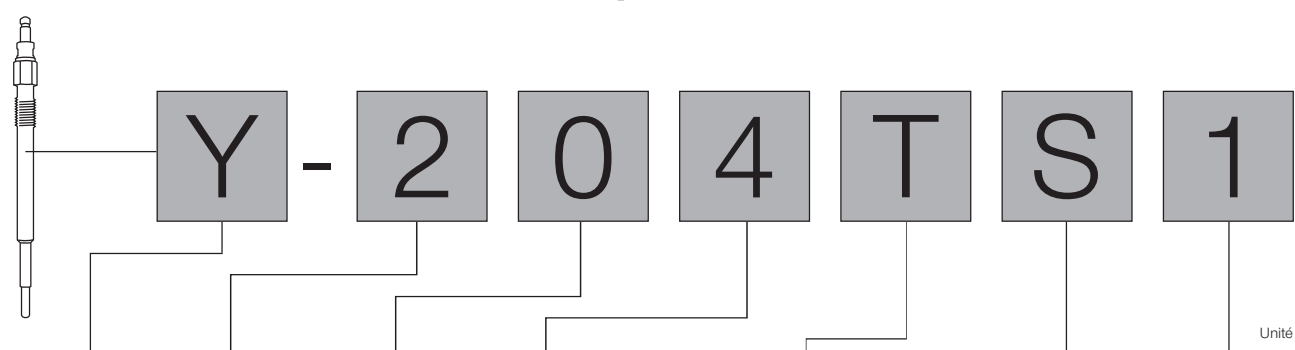

Unité : mm

Y		-2		0		4		T		S		1			
	Modèle / Type	Diamètre de filetage		Tension de batterie		Numéro de série		Caractéristique thermique		Type de matériau		Indice d'évolution			
Y/YS	Bougie de préchauffage à masse par le culot (Unipôle)	1	10 mm	0-4	12 V	Ce chiffre est le numéro de série		A	Type AQGS	S	Spécial				
		2	12 mm	5-9	24 V			J	Type SRM	Aucun	Standard				
		3	10 mm					K ou pas de lettre		Type standard					
		4	14 mm					R, M, U		Type QGS					
YD	Bougie de préchauffage isolée (dipôle)	5	10 mm					T, V		Type démarrage rapide					
		6	10 mm					Remarque : Y-7XXR et Y-9XXR sont des types SRM							
		7	10 mm					Explication							
		8	18 mm					AQGS		Advanced Quick Glow System (système de préchauffage rapide avancé)					
		9	12 mm					SRM		Self Regulating Metal Glow Plug (bougie de préchauffage auto-régulante)					
				*Y-109, Y-159, Y-171 pour Caterpillar / Mitsubishi ont un diamètre de filetage de 3/8" (environ 9.5 mm)				QGS		Quick Glow System (système de préchauffage rapide)					

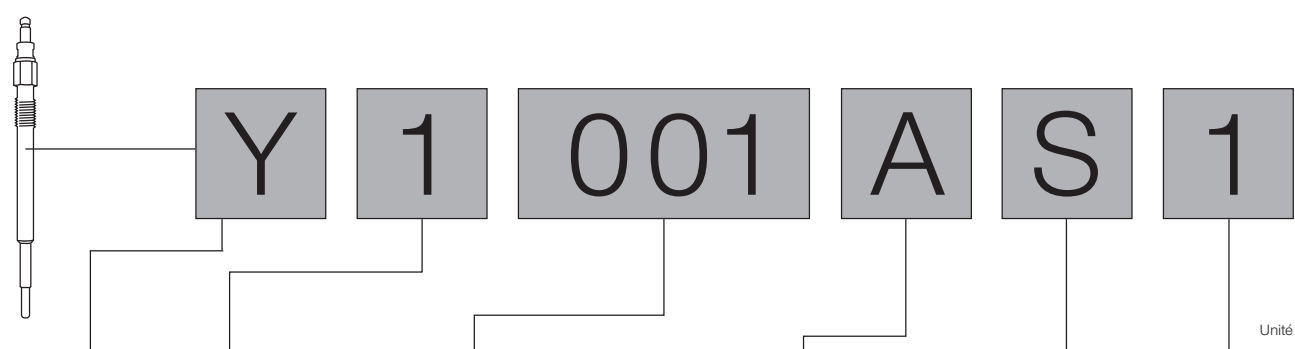

Unité : mm

Y		1		001		A		S		1			
	Modèle / Type	Diamètre de filetage		Numéro de série / Tension de batterie		Caractéristique thermique		Type de matériau		Indice d'évolution			
Y	Bougie de préchauffage à masse par le culot	1	10 mm	001-899	12 V	A	Type AQGS	S	Spécial				
		2	12 mm	900-999	24 V	J	Type SRM	Aucun	Standard				
		4	14 mm			K ou pas de lettre		Type standard					
		8	8 mm			R, M, U		Type QGS					
		9	9 mm			T, V		Type démarrage rapide					
						Explication							
								AQGS		Advanced Quick Glow System (système de préchauffage rapide avancé)			
								SRM		Self Regulating Metal Glow Plug (bougie de préchauffage auto-régulante)			
								QGS		Quick Glow System (système de préchauffage rapide)			



Comment lire notre numéro de pièce:



Y A 01

Unité : mm

Y	A	01
Modèle / Type	Caractéristique thermique	Numéro de série
Bougie de préchauffage à masse par le culot Thread size: 8mm or 9mm	A Type standard	
	E Type QGS Type SRM	

Comment lire notre numéro de pièce: Bougies de préchauffage en métal



C Z 101

Unité : mm

C	Z	101
Modèle / Type	Caractéristique thermique	Numéro de série
Bougie de préchauffage céramique	X QGS Type Quick Glow System (Système Quick Glow)	
	Y SRC Type / HTC Self Regulating Ceramic Glow Plug (Bougie de préchauffage en céramique auto-régulatrice)	
	Z NHTC Type Quick Glow System (Système Quick Glow)	

Remarques concernant le tableau

- △ = uniquement pour les véhicules avec anti-démarrage
- ◆ = uniquement pour les véhicules sans anti-démarrage

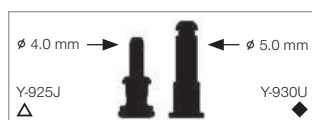

Come leggere il nostro numero del pezzo:



Y - 2 0 4 T S 1

Unità: mm

Y		-2		0		4		T		S		1	
	Versione / Tipo	Diametro filettatura		Vtaggio		Numero di serie		Caratteristica di temperatura		Materiale del bulbo		Codice modifica	
Y/YS	Candeletta a bulbo metallico	1	10 mm	0-4	12 V	Questa cifra è il numero di serie		A	Tipo AQGS	S	Speciale		
		2	12 mm	5-9	24 V			J	Tipo SRM	Nessuno	Standard		
YD	Candeletta a bulbo metallico con doppio isolatore	3	10 mm					K o nessuna lettera	Tipo standard				
		4	14 mm					R, M, U	Tipo QGS				
		5	10 mm					T, V	Tipo ad riscaldamento rapido				
		6	10 mm					Nota: I tipi Y-7XXR e Y-9XXR sono SRM					
		7	10 mm										
		8	18 mm										
		9	12 mm										
		*Y-109, Y-159, Y-171 per Caterpillar /Mitsubishi hanno un diametro della filettatura di 3/8" (circa 9,5 mm)											
								Spiegazione AQGS Advanced Quick Glow System SRM Self Regulating Metal Glow Plug QGS Quick Glow System					



Y 1 001 A S 1

Unità: mm

Y		1		001		A		S		1	
	Versione / Tipo	Diametro filettatura		Numero di serie Tensione batteria		Caratteristica di temperatura		Materiale del bulbo		Codice modifica	
Y	Candeletta a spirale singola	1	10 mm	001-899	12 V	A	Tipo AQGS	S	Speciale		
		2	12 mm	900-999	24 V	J	Tipo SRM	Nessuno	Standard		
		4	14 mm			Spiegazione AQGS Advanced Quick Glow System SRM Self Regulating Metal Glow Plug QGS Quick Glow System		K o nessuna lettera	Tipo standard		
		8	8 mm					R, M, U	Tipo QGS		
		9	9 mm					T, V	Tipo ad riscaldamento rapido		

Come leggere il nostro numero del pezzo:



Y A 01

Unità: mm

Y	A	01
Versione / Tipo	Caratteristica di temperatura	Numero di serie
Candeletta a spirale singola Diametro filettatura: 8 mm o 9 mm	A Tipo standard	
	E Tipo QGS o tipo SRM	

Come leggere il nostro numero del pezzo: candelette con bulbo ceramico



C Z 101

Unità: mm

C	Z	101
Versione / Tipo	Caratteristica di temperatura	Numero di serie
Candeletta con bulbo ceramico	X QGS Type Quick Glow System (Sistema a riscaldamento rapido)	
	Y SRC Type / HTC Self Regulating Ceramic Glow Plug (Candelette ceramiche autoregolanti)	
	Z NHTC Type Quick Glow System (Sistema a riscaldamento rapido)	

Note sulla tabella

- △ = solo per veicoli con immobilizer
- ◆ = solo per veicoli senza immobilizer

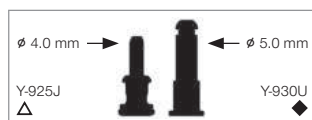

Cómo leer nuestros números de pieza: Calentadores metálicos

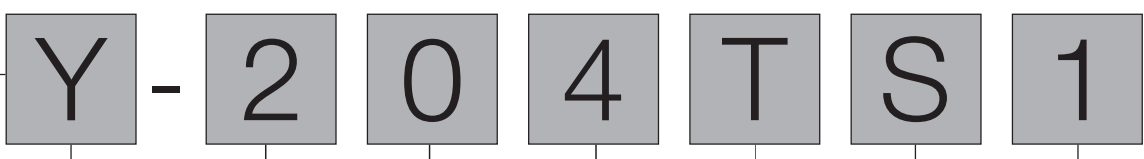

Unidad: mm

Y		-2		0		4		T		S		1	
	Modelo / Tipo	Diámetro de la rosca		Tensión de la batería		Número de serie		Características de incandescencia		Material de la varilla		Número de modificación	
Y/YS	Calentador Metálico	1	10 mm	0-4	12 V	Esta cifra indica el número de serie		A	Tipo AQGS	S	Especial		
		2	12 mm	5-9	24 V			J	Tipo SRM	Ninguno	Estándar		
YD	Calentador con doble aislador	3	10 mm					K o ninguna letra		Tipo estándar			
		4	14 mm					R, M, U		Tipo QGS			
		5	10 mm					T, V		Tipo de arranque rápido			
		6	10 mm					Nota: Y-7XXR y Y-9XXR son tipos SRM					
		7	10 mm					Explicación					
		8	18 mm					AQGS		Calentamiento inmediato, sistema avanzado			
		9	12 mm					SRM		Metálico auto regulado			
		*Y-109, Y-159, Y-171 para Caterpillar / Mitsubishi tienen un diámetro de rosca de 3/8" (aprox. 9.5 mm)		QGS		Calentamiento inmediato							

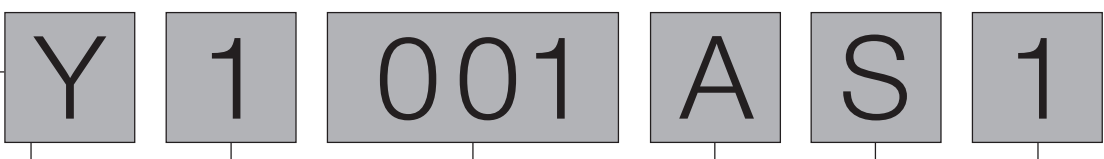

Unidad: mm

Y		1		001		A		S		1	
	Modelo / Tipo	Diámetro de la rosca		Número de serie / Tensión de la batería		Características de incandescencia		Material de la varilla		Número de modificación	
Y	Calentador metálico	1	10 mm	001-899	12 V	A	Tipo AQGS	S	Especial		
		2	12 mm	900-999	24 V	J	Tipo SRM	Ninguno	Estándar		
		4	14 mm			K o ninguna letra		Tipo estándar			
		8	8 mm			R, M, U		Tipo QGS			
		9	9 mm			T, V		Tipo de arranque rápido			
				Explicación		AQGS		Calentamiento inmediato, sistema avanzado			
				SRM		Metálico auto regulado					
				QGS		Calentamiento inmediato					



Cómo leer nuestros números de pieza: Calentadores metálicos

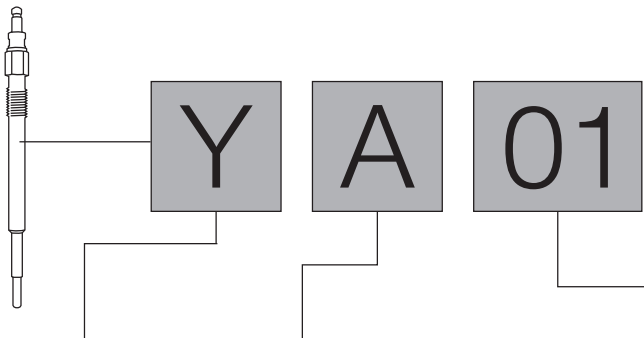

Unidad: mm

Y	A	01
Modelo / Tipo	Características de incandescencia	Número de serie
Calentador Metálico Diámetro de la rosca: 8 mm o 9 mm	A Tipo estándar	
	E Tipo QGS o tipo SRM	

Cómo leer nuestros números de pieza: Calentadores cerámicos

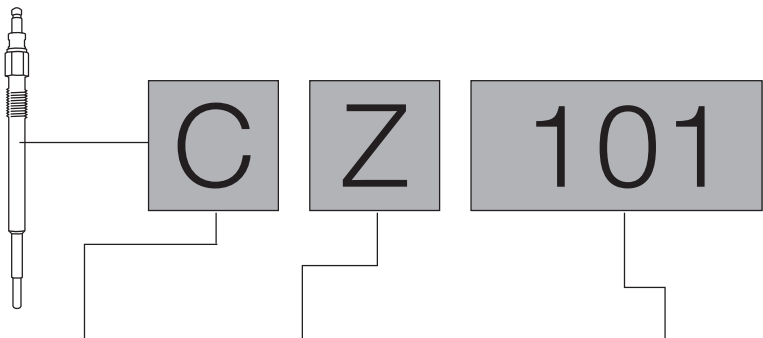

Unidad: mm

C	Z	101
Modelo / Tipo	Características de incandescencia	Número de serie
Candeleta con bulbo cerámico	X QGS Type Sistema Quick Glow	
	Y SRC Type / HTC Calentador cerámico autorregulado	
	Z NHTC Type Sistema Quick Glow	

Notas respecto a la tabla

- △ = solo para vehículos con inmovilizador
- ◆ = solo para vehículos sin inmovilizador

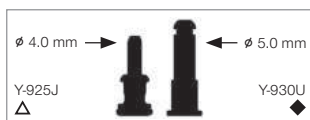

Hoe moet ons onderdeelnummer worden gelezen:



Eenheid: mm

Y		-2		0		4		T		S		1	
	Uitvoering / Type	Schroefdraaddiameter		Batterijspanning		Serienummer		Gloeikarakteristiek		Gloeistaafmateriaal		Modificatienummer	
Y/YS	Staafgloeibougie	1	10 mm	0-4	12 V	Dit getal is het serienummer		A	AQGS type	S	Speciaal		
YD	Staafgloeibougie met dubbele isolator	2	12 mm	5-9	24 V			J	SRM type	Geen	Standaard		
		3	10 mm					K of geen letter	Standaard type				
		4	14 mm					R, M, U	QGS type				
		5	10 mm					T, V	Snelstart type				
		6	10 mm					Opmerking: Y-7XXR en Y-9XXR zijn SRM- types					
		7	10 mm					Verklaring					
		8	18 mm					AQGS Advanced Quick Glow System					
		9	12 mm					SRM Self Regulating Metal Glow Plug					
		*Y-109, Y-159, Y-171 voor Caterpillar / Mitsubishi hebben een schroefdraaddiameter van 3/8" (ca. 9.5mm)						QGS Quick Glow System					



Eenheid: mm

Y		1		001		A		S		1	
	Uitvoering / Type	Schroefdraaddiameter		Serienummer / Batterijspanning		Gloeikarakteristiek		Gloeistaafmateriaal		Modificatienummer	
Y	Staafgloeibougie	1	10 mm	001-899	12 V	A	AQGS type	S	Speciaal		
		2	12 mm	900-999	24 V	J	SRM type	Geen	Standaard		
		4	14 mm			K of geen letter		Standaard type			
		8	8 mm			R, M, U		QGS type			
		9	9 mm			T, V		Snelstart type			
								Verklaring			
								AQGS Advanced Quick Glow System			
								SRM Self Regulating Metal Glow Plug			
								QGS Quick Glow System			



Hoe moet ons onderdeelnummer worden gelezen:

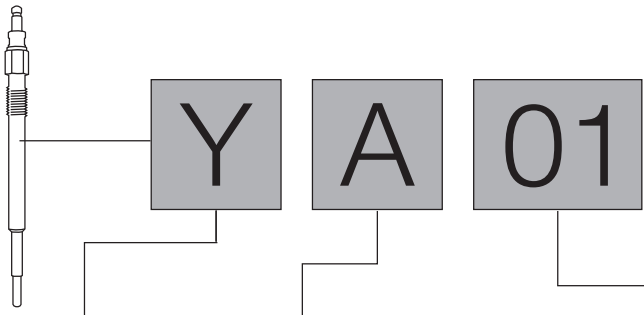

Diagram showing a spark plug with callouts for the characters **Y**, **A**, and **01**.

Eenheid: mm

Y	A	01
Uitvoering / Type	Gloeikarakteristiek	Serienummer
Staaflgloeibougie Schroefdraaddiameter: 8 mm of 9 mm	A Standaard type	
	E QGS type of SRM type	

Hoe moet ons onderdeelnummer worden gelezen: Keramische gloeibougies

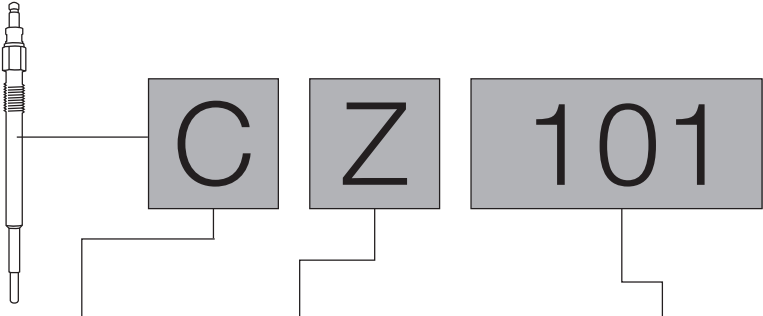

Diagram showing a ceramic glow plug with callouts for the characters **C**, **Z**, and **101**.

Eenheid: mm

C	Z	101
Uitvoering / Type	Gloeikarakteristiek	Serienummer
Keramische gloeibougies	X QGS Type Quick Glow System	
	Y SRC Type / HTC Self Regulating Ceramic Glow Plug (Zelfregelende keramische gloeibougie)	
	Z NHTC Type Quick Glow System	

Opmerkingen bij de tabel

- △ = uitsluitend voor voertuigen met wegrijbeveiliging
- ◆ = uitsluitend voor voertuigen zonder wegrijbeveiliging

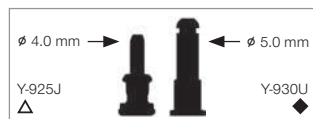

Como ler o nosso número de peça:



Unidade : mm

Y		-2		0		4		T		S		1	
Acabamento / Tipo	Tamanho da rosca		Voltagem da bateria		Número de série		Característica de incandescência		Material do tubo		Número de alteração do projecto		
Y/YS	Vela incandescente	1	10 mm	0-4	12 V	Esta cifra é o número de série		A	Tipo AQGS	S	Especial		
YD	Vela incandescente com isolador duplo	2	12 mm	5-9	24 V			J	Tipo SRM	Nenhum	Padrão		
		3	10 mm					K ou nenhum letra	Tipo padrão				
		4	14 mm					R, M, U	Tipo QGS				
		5	10 mm					T, V	Tipo arranque rápido				
		6	10 mm					Nota: Y-7XXR e Y-9XXR são tipos SRM					
		7	10 mm					Explicação					
		8	18 mm					AQGS Advanced Quick Glow System (Sistema avançado de pré-aquecimento rápido)					
		9	12 mm					SRM Self Regulating Metal Glow Plug (Tipo autoregulado)					
		*Y-109, Y-159, Y-171 para Caterpillar / Mitsubishi possuem diâmetro de rosca de 3/8" (aprox. 9,5mm)						QGS Quick Glow System (Sistema de pré-aquecimento rápido)					



Unidade : mm

Y		1		001		A		S		1	
Acabamento / Tipo	Tamanho da rosca		Número de série / Voltagem da bateria		Característica de incandescência		Material do tubo		Número de alteração do projecto		
Y	Vela incandescente	1	10 mm	001-899	12 V	A	Tipo AQGS	S	Especial		
		2	12 mm	900-999	24 V	J	Tipo SRM	Nenhum	Padrão		
		4	14 mm			K ou nenhum letra	Tipo padrão				
		8	8 mm			R, M, U	Tipo QGS				
		9	9 mm			T, V	Tipo arranque rápido				
						Explicação					
						AQGS Advanced Quick Glow System (Sistema avançado de pré-aquecimento rápido)					
						SRM Self Regulating Metal Glow Plug (Tipo autoregulado)					
						QGS Quick Glow System (Sistema de pré-aquecimento rápido)					



Como ler o nosso número de peça:

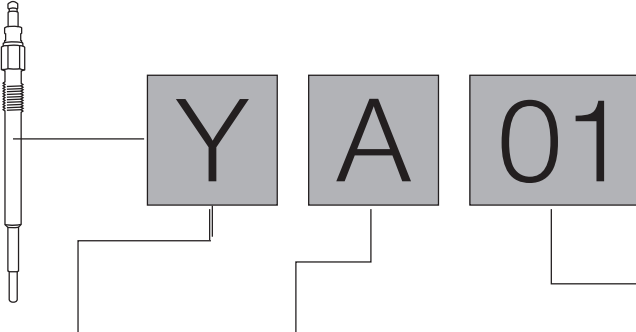

Unidade : mm

Y	A	01
Acabamento / Tipo	Característica de incandescência	Número de série
Vela incandescente Diâmetro da rosca: 8mm ou 9mm	A Tipo padrão E Tipo QGS outipo SRM	

Como ler o nosso número de peça: Velas de Incandescência em Cerâmica

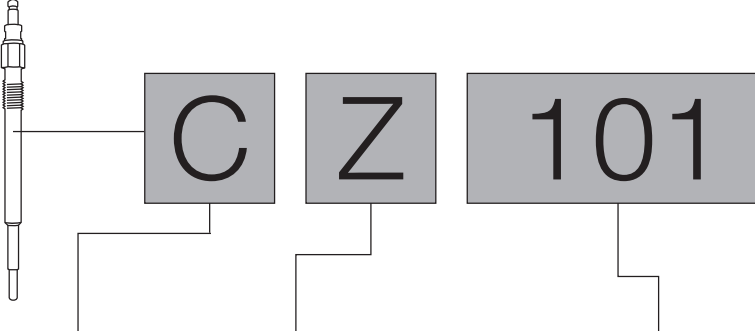

Unidade : mm

C	Z	101
Acabamento / Tipo	Característica de incandescência	Número de série
Vela de incandescência cerâmica	X QGS Type Quick Glow System (Sistema de Incandescência Rápida) Y SRC Type / HTC Self Regulating Ceramic Glow Plug (Vela de Incandescência Cerâmica Autorreguladora) Z NHTC Type Quick Glow System (Sistema de Incandescência Rápida)	

Anotações à tabela

- △ = apenas para veículos com imobilizador
- ◆ = apenas para veículos sem imobilizador

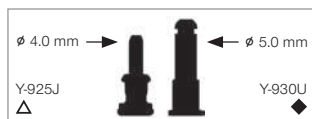

Πώς να ερμηνεύετε τους κωδικούς μας:



Y - 2 0 4 T S 1

Μονάδα: mm

Y		-2		0		4		T		S		1	
Εκτέλεση / Τύπος		Διάμετρος σπειρώματος		Τάση μπαταρίας		Τάση μπαταρίας		Χαρακτηριστικά πυράκτωσης		Υλικό ράβδου πυράκτωσης		Αριθμός Διάμετρος τροποποίησης	
Y/YS	Προθερμαντήρας ράβδου	1	10 mm	0-4	12 V	Αυτό το ψηφίο αποτελεί τον αριθμό σειράς	A	Τύπος AQGS	S	Ειδικός	Αριθμός Διάμετρος τροποποίησης		
		2	12 mm	5-9	24 V		J	Τύπος SRM				Καινένος	Στάνταρ
YD	Προθερμαντήρας ράβδου με διπλό μονωτήρα	3	10 mm	*Y-109, Y-159, Y-171 για Caterpillar / Mitsubishi έχουν μια διάμετρος σπειρώματος από 3/8" (περ. 9,5 mm)	Αυτό το ψηφίο αποτελεί τον αριθμό σειράς		K ή κανένα γράμμα	Στάνταρ τύπος	Αριθμός Διάμετρος τροποποίησης				
		4	14 mm				R, M, U	Τύπος QGS					
		5	10 mm				T, V	Τύπος γρήγορης εκκίνησης					
		6	10 mm				Σημείωση: Y-7XXR και Y-9XXR αποτελούν τύπους SRM						
		7	10 mm				Επεξήγηση						
		8	18 mm				AQGS Advanced Quick Glow System						
		9	12 mm				SRM Self Regulating Metal Glow Plug						
						QGS Quick Glow System							



Y 1 001 A S 1

Μονάδα: mm

Y		1		001		A		S		1	
Εκτέλεση / Τύπος		Διάμετρος σπειρώματος		Αριθμός σειράς / Τάση μπαταρίας		Χαρακτηριστικά πυράκτωσης		Υλικό ράβδου πυράκτωσης		Αριθμός Διάμετρος τροποποίησης	
Y	Προθερμαντήρας ράβδου	1	10 mm	001-899	12 V	A	Τύπος AQGS	S	Ειδικός	Αριθμός Διάμετρος τροποποίησης	
		2	12 mm	900-999	24 V	J	Τύπος SRM				Καινένος
		4	14 mm	Αριθμός Διάμετρος τροποποίησης							
		8	8 mm		K ή κανένα γράμμα	Στάνταρ τύπος					
		9	9 mm		R, M, U	Τύπος QGS					
					T, V		Τύπος γρήγορης εκκίνησης				
					Επεξήγηση		AQGS Advanced Quick Glow System				
						SRM Self Regulating Metal Glow Plug					
						QGS Quick Glow System					

Πώς να ερμηνεύετε τους κωδικούς μας:

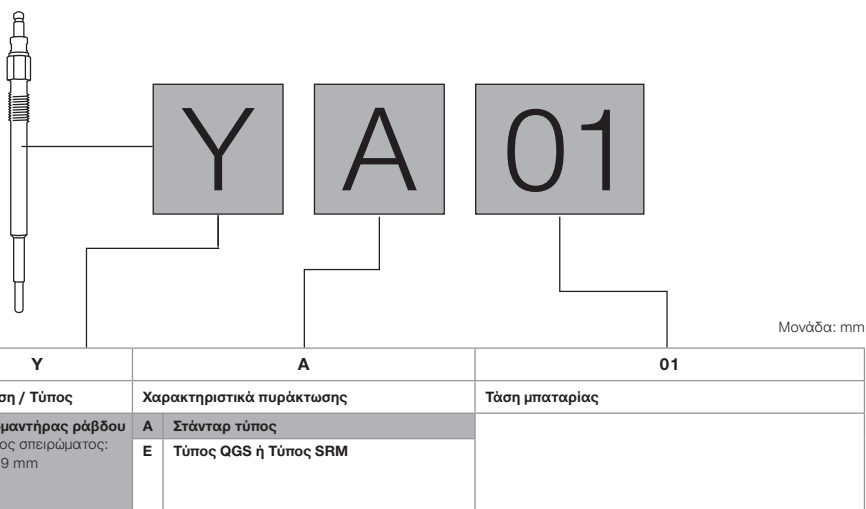

Πώς να ερμηνεύετε τους κωδικούς μας: Κεραμικοί προθερμαντήρες

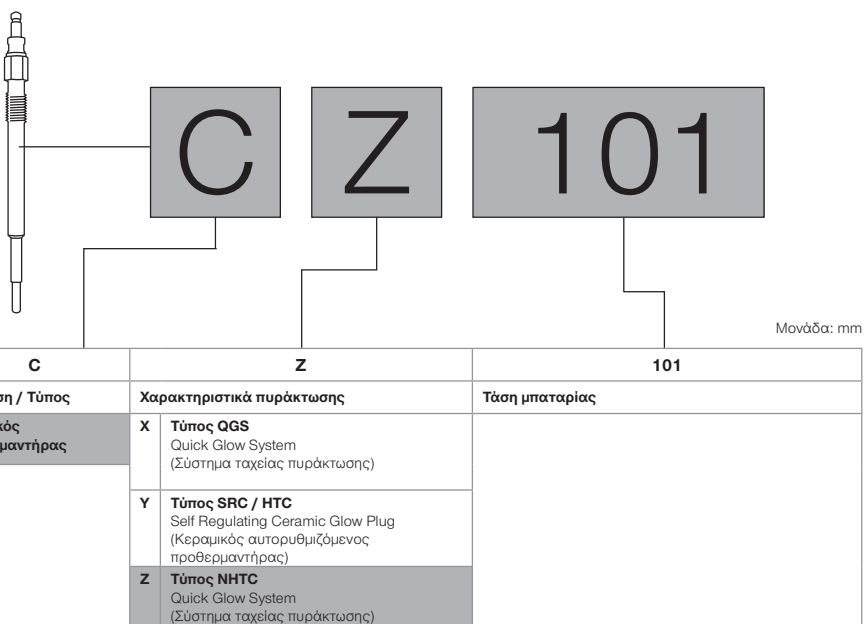

Παρατηρήσεις για τον πίνακα

- △ = μόνο για οχήματα με Immobilizer
- ◆ = μόνο για οχήματα χωρίς Immobilizer

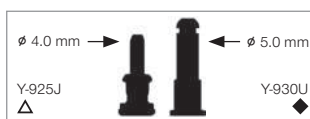

Parça numaramızın okunma şekli: Metal Kızdırma Bujileri



Y - 2 0 4 T S 1

Birim: mm

Y		-2		0		4		T		S		1	
Model / Tip	Diş çapı		Akü gerilimi		Seri numarası		Kızdırma karakteristiği		Kızdırma çubuk materyali		Modifikasyon numarası		
Y/YS	Çubuk tipi	1	10 mm	0-4	12 V	Bu rakam seri numarasıdır		A	AQGS tipi	S	Özel		
	kızdırma bujisi	2	12 mm	5-9	24 V			J	SRM tipi	Yok	Standart		
YD	Çift izolatörlü çubuk tipi kızdırma bujisi	3	10 mm					K veya harfsiz	Standart tip				
		4	14 mm										
		5	10 mm										
		6	10 mm										
		7	10 mm										
		8	18 mm										
		9	12 mm										
		*Y-109, Y-159, Y-171 kızdırma bujilerin diş çapı Caterpillar / Mitsubishi için 3/8" (yaklaşık 9.5mm)											
		Not: Y-7XXR ve Y-9XXR, SRM tipidir											
		Açıklama											
		AQGS Advanced Quick Glow System											
		SRM Self Regulating Metal Glow Plug											
		QGS Quick Glow System											



Y 1 001 A S 1

Birim: mm

Y		1		001		A		S		1	
Model / Tip	Diş çapı		Seri numarası / Akü gerilimi		Kızdırma karakteristiği		Kızdırma çubuk materyali		Modifikasyon numarası		
Y	Çubuk tipi	1	10 mm	001-899	12 V	A	AQGS tipi	S	Special		
	kızdırma bujisi	2	12 mm	900-999	24 V	J	SRM tipi	None	Standard		
		4	14 mm								
		8	8 mm								
		9	9 mm								
		Açıklama									
		AQGS Advanced Quick Glow System									
		SRM Self Regulating Metal Glow Plug									
		QGS Quick Glow System									

Parça numaramızın okunma şekli: Metal Kızdırma Bujileri



Y A 01

Birim: mm

Y	A	01
Model / Tip	Kızdırma karakteristiği	Seri numarası
Çubuk tipi kızdırma bujisi Diş çapı: 8mm veya 9mm	A Standart tip	
	E QGS tipi veya SRM tipi	

Parça numaramızın okunma şekli: Seramik Kızdırma Bujileri



C Z 101

Birim: mm

C	Z	101
Model / Tip	Kızdırma karakteristiği	Seri numarası
Seramik kızdırma bujisi	X QGS tipi Quick Glow System (Hızlı Kızdırma Sistemi)	
	Y SRC tipi / HTC Self Regulating Ceramic Glow Plug (Kendi Kendini Ayarlayan Seramik Kızdırma Bujisi)	
	Z NHTC tipi Quick Glow System (Hızlı Kızdırma Sistemi)	

Tablo notu

- △ = sadece Immobilizer'lı araçlar için
- ◆ = sadece Immobilizer'ı olmayan araçlar için

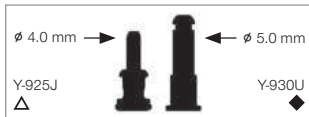

Jak odczytać numer części: Metalowe świece żarowe



Y - **2** **0** **4** **T** **S** **1**

Jednostka: mm

Y		-2		0		4		T		S		1	
	Wykonanie / type	Średnica gwintu		Napięcie robocze		Numer seryjny		Charakterystyka żarzenia		Materiał prętu grzewczego		Numer modyfikacji	
Y/YS	Świece żarowa jednobiegunowa	1	10 mm	0-4	12 V	Ta cyfra oznacza numer seryjny		A	Typ AQGS	S	Specjalne		
		2	12 mm	5-9	24 V			J	Typ SRM	Brak	Standardowe		
YD	Świece żarowe dwubiegunowe	3	10 mm					K lub brak litery	Typ standardowy				
		4	14 mm										
		5	10 mm										
		6	10 mm										
		7	10 mm										
		8	18 mm										
9	12 mm	*Y-109, Y-159, Y-171 dla Caterpillar/ Mitsubishi posiadają średnicę gwintu 3/8" (ok. 9,5mm)											
								Uwaga: Y-7XXR i Y-9XXR to produkty typu SRM Objaśnienia: AQGS Advanced Quick Glow System (Zaawansowany system szybkiego żarzenia) SRM Self Regulating Metal Glow Plug (Typ samoregulacyjny) QGS Quick Glow System (System szybkiego żarzenia)					



Y **1** **001** **A** **S** **1**

Jednostka: mm

Y		1		001		A		S		1			
	Wykonanie / type	Średnica gwintu		Numer seryjny / Napięcie robocze		Charakterystyka żarzenia		Materiał prętu grzewczego		Numer modyfikacji			
Y	Świece żarowa jednobiegunowa	1	10 mm	001-899	12 V	A		A	Typ AQGS	S	Specjalne		
		2	12 mm	900-999	24 V			J	Typ SRM	Brak	Standardowe		
		4	14 mm					K lub brak litery	Typ standardowy				
		8	8 mm										
		9	9 mm										
								Objaśnienia: AQGS Advanced Quick Glow System (Zaawansowany system szybkiego żarzenia) SRM Self Regulating Metal Glow Plug (Typ samoregulacyjny) QGS Quick Glow System (System szybkiego żarzenia)					



Jak odczytać numer części: Metalowe świece żarowe

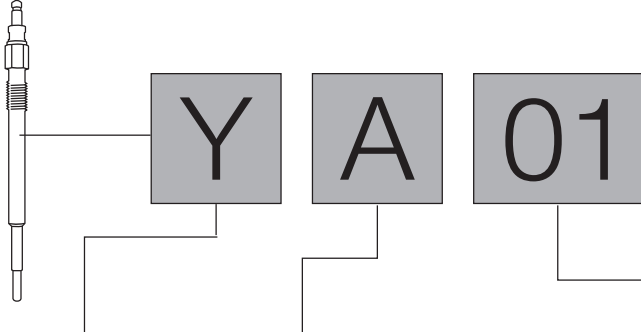

Jednostka: mm

Y	A	01
Wykonanie / type	Charakterystyka żarzenia	Numer seryjny
Świeca żarowa jednobiegunowa Średnica gwintu: 8mm lub 9mm	A Typ standardowy	
	E Typ QGS lub typ SRM	

Jak odczytać numer części: Ceramiczne świece żarowe

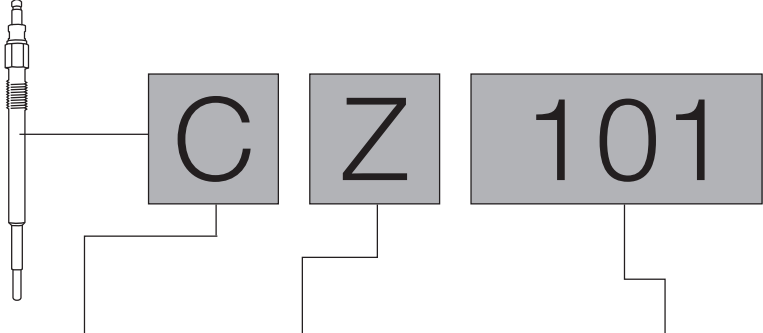

Jednostka: mm

C	Z	101
Wykonanie / type	Charakterystyka żarzenia	Numer seryjny
Świece żarowe ceramiczne	X QGS Type Quick Glow System System szybkiego żarzenia (QGS)	
	Y SRC Type / HTC Self Regulating Ceramic Glow Plug (Samoregułująca się ceramiczna świeca żarowa)	
	Z NHTC Type Quick Glow System System szybkiego żarzenia (QGS)	

Uwagi do tabeli

- △ = tylko do pojazdów z blokadą przeciwruchomieniową
- ◆ = tylko do pojazdów bez blokady przeciwruchomieniowej

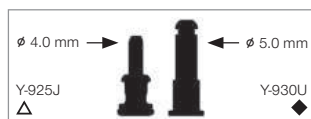

Jak číst naše číslo dílu: Kovové žhavicí svíčky



Y - 2 0 4 T S 1

Jednotky: mm

Y		-2		0		4		T		S		1	
	Provedení / typ	Průměr závitů		Napětí akumulátoru		Sériové číslo		Charakteristika žhavení		Materiál žhavicí tyčky		Číslo modifikace	
Y/YS	Tyčová žhavicí svíčka	1	10 mm	0-4	12 V	Toto číslo je sériové číslo		A	AQGS typ	S	Speciální		
		2	12 mm	5-9	24 V			J	SRM typ	Žádný	Standardní		
YD	Tyčová žhavicí svíčka s dvojitým izolátorem	3	10 mm					K nebo žádné písmeno		Standardní typ			
		4	14 mm					R, M, U		QGS typ			
		5	10 mm					T, V		Typ rychlý start			
		6	10 mm					Poznámka: Y-7XXR a Y-9XXR jsou typy SRM					
		7	10 mm					Vysvětlení					
		8	18 mm					AQGS		Advanced Quick Glow System			
		9	12 mm					SRM		Self Regulating Metal Glow Plug			
		*Y-109, Y-159, Y-171 pro Caterpillar / Mitsubishi mají průměr závitů 3/8" (cca 9,5mm)		QGS		Quick Glow System							



Y 1 001 A S 1

Jednotky: mm

Y		1		001		A		S		1			
	Provedení / typ	Průměr závitů		Sériové číslo / Napětí akumulátoru		Charakteristika žhavení		Materiál žhavicí tyčky		Číslo modifikace			
Y	Tyčová žhavicí svíčka	1	10 mm	001-899	12 V	A		AQGS typ		S	Speciální		
		2	12 mm	900-999	24 V			J		SRM typ			
		4	14 mm					K nebo žádné písmeno		Standardní typ			
		8	8 mm					R, M, U		QGS typ			
		9	9 mm					T, V		Typ rychlý start			
				Vysvětlení		AQGS		Advanced Quick Glow System					
				SRM		Self Regulating Metal Glow Plug		QGS		Quick Glow System			

Jak číst naše číslo dílu: Kovové žhavicí svíčky



Y A 01

Jednotky: mm

Y	A	01
Provedení / typ	Charakteristika žhavení	Sériové číslo
Tyčová žhavicí svíčka Průměr závitu: 8 mm nebo 9 mm	A Standardní typ	
	E QGS typ nebo SRM typ	

Jak číst naše číslo dílu: Keramické žhavicí svíčky



C Z 101

Jednotky: mm

C	Z	101
Provedení / typ	Charakteristika žhavení	Sériové číslo
Keramická žhavicí svíčka	X QGS Type Systém rychlého žhavení	
	Y SRC Type / HTC Samoregulační keramická žhavicí svíčka	
	Z NHTC Type Systém rychlého žhavení	

Poznámky k tabulce

- △ = pouze pro vozidla s imobilizérem
- ◆ = pouze pro vozidla bez imobilizéru

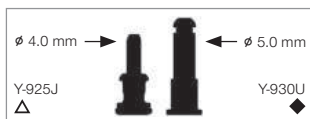

Hogyan kell leolvasni a cikkszámot: Fémházas izzítógyertyák



Y - 2 0 4 T S 1

Egység: mm

Y		-2		0		4		T		S		1	
	kivitel / típus	menet átmérő		akku feszültség		sorozatszám		izzítási karakterisztika		izzórúd anyaga		változtatási	
Y/YS	Rúd izzítógyertya	1	10 mm	0-4	12 V	A szám a sorozatszám		A	AQGS típus	S	Speciális		
YD	Rúd izzítógyertya kettős szigetelővel	2	12 mm	5-9	24 V			J	SRM típus	Egyik sem	Standard		
		3	10 mm					K vagy betű nélkül		Normál típus			
		4	14 mm					R, M, U		QGS típus			
		5	10 mm					T, V		Gyorsindító típus			
		6	10 mm					Megjegyzés: Y-7XXR és Y-9XXR SRM típusúak Magyarázat					
		7	10 mm					AQGS Advanced Quick Glow System					
		8	18 mm					SRM Self Regulating Metal Glow Plug					
		9	12 mm					QGS Quick Glow System					
		*Y-109, Y-159, Y-171 Caterpillar / Mitsubishi típusokhoz menetük átmérője 3/8" (kb. 9,5 mm)											



Y 1 001 A S 1

Egység: mm

Y		1		001		A		S		1	
	kivitel / típus	menet átmérő		sorozatszám / akku feszültség		izzítási karakterisztika		izzórúd anyaga		változtatási	
Y	Rúd izzítógyertya	1	10 mm	001-899	12 V	A	AQGS típus	S	Speciális		
		2	12 mm	900-999	24 V	J	SRM típus	Egyik sem	Standard		
		4	14 mm			K vagy betű nélkül		Normál típus			
		8	8 mm			R, M, U		QGS típus			
		9	9 mm			T, V		Gyorsindító típus			
						Magyarázat					
						AQGS Advanced Quick Glow System					
						SRM Self Regulating Metal Glow Plug					
						QGS Quick Glow System					



Hogyan kell leolvasni a cikkszámot: Fémházas izzítógyertyák

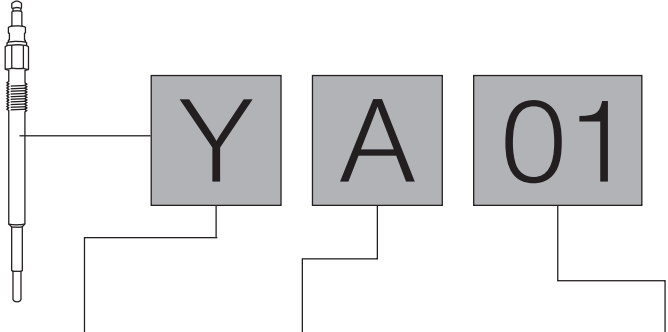

Egység: mm

Y	A	01
kivitel / típus	izzítási karakterisztika	sorozatszám
Rúd izzítógyertya Menet átmérő: 8 vagy 9 mm	A Normál típus	
	E QGS típus vagy SRM típus	

Hogyan kell leolvasni a cikkszámot: Kerámia izzítógyertyák

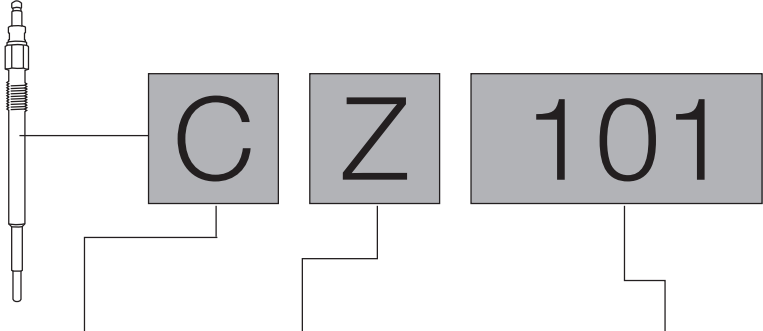

Egység: mm

C	Z	101
kivitel / típus	izzítási karakterisztika	sorozatszám
Kerámia izzítógyertya	X QGS típus Quick Glow System (Gyorsizzító rendszer)	
	Y SRC típus / HTC Self Regulating Ceramic Glow Plug (Önszabályozó kerámia izzítógyertya)	
	Z NHTC típus Quick Glow System (Gyorsizzító rendszer)	

Megjegyzések a táblázathoz

- △ = csak immobiliseres autókhoz
- ◆ = csak immobiliser nélküli autókhoz

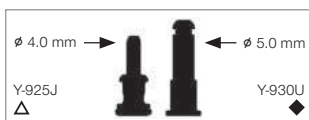

Что означает код детали:



Y - 2 0 4 T S 1

Единица измерения : мм

Y		-2	0	4	T		S		1		
Исполнение / Тип	Диаметр резьбы	Напряжение батареи		Номер серии	Характеристика накаливания		Материал штифта накаливания		Номер модификации		
Y/YS Штифтовая свеча накаливания	1 10 мм	0-4 12 В		Эта цифра является номером серии	A	Тип AQGS	S	Специальная			
	2 12 мм	5-9 24 В			J	Тип SRM	Отсутствует	Стандартная			
	3 10 мм				К или без буквы		Стандартный тип				
YD Штифтовая свеча накаливания с некорпусным заземлением	4 14 мм				R, M, U	Тип QGS					
	5 10 мм				T, V	Тип с ускоренным нагревом					
	6 10 мм				Примечание: Y-7XXR и Y-9XXR – свечи типа SRM						
	7 10 мм				Пояснение						
	8 18 мм				AQGS Advanced Quick Glow System (Улучшенная система быстрого накаливания)						
	9 12 мм				SRM Self Regulating Metal Glow Plug (Саморегулирующийся тип, металл)						
				QGS Quick Glow System (Система быстрого накаливания)							



Y 1 001 A S 1

Единица измерения : мм

Y		1	001		A		S		1
Исполнение / Тип	Диаметр резьбы	Номер серии / Напряжение батареи		Характеристика накаливания		Материал штифта накаливания		Номер модификации	
Y Sheathed type	1 10 мм	001-899	12 В		A	Тип AQGS	S	Специальная	
	2 12 мм	900-999	24 В		J	Тип SRM	Отсутствует	Стандартная	
	4 14 мм			К или без буквы		Стандартный тип			
	8 8 мм			R, M, U		Тип QGS			
	9 9 мм			T, V		Тип с ускоренным нагревом			
				Пояснение					
				AQGS Advanced Quick Glow System (Улучшенная система быстрого накаливания)					
				SRM Self Regulating Metal Glow Plug (Саморегулирующийся тип, металл)					
				QGS Quick Glow System (Система быстрого накаливания)					



Что означает код детали:

Единица измерения : мм

Y	A	01
Исполнение / Тип	Характеристика накаливания	Номер серии
Штифтовая свеча накаливания Диаметр резьбы: 8 мм или 9 мм	A Стандартный тип	
	E Тип QGS или Тип SRM	

Что означает код детали: Керамические свечи накаливания

Единица измерения : мм

C	Z	101
Исполнение / Тип	Характеристика накаливания	Номер серии
Керамическая свеча накаливания	X QGS Type Quick Glow System (Система быстрого накаливания)	
	Y SRC Type / НТС Self Regulating Ceramic Glow Plug (Саморегулирующаяся керамическая свеча накаливания)	
	Z ННТС Type Quick Glow System (Система быстрого накаливания)	

Примечания к таблице

- △ = только для автомобилей с иммобилайзером
- ◆ = только для автомобилей без иммобилайзера

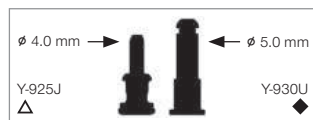



IMPORTANT TIPS FOR THE INSTALLATION OF SPARK PLUGS

A torque wrench is required for the professional installation of a spark plug. Even for professionals the estimation of the tightening torque is nearly impossible. That is because a torque can be calculated from two sizes which are multiplied by one another: the force which is applied to the respective centre of rotation and the length of the

handle. Most spark plug failures can be traced back to an incorrect tightening torque. If it is set too low, there is a risk of compression losses and overheating. A break of the insulator or middle electrode as a result of vibrations is also feasible. If the tightening torque is set too high, the spark plug can snap off. The casing can also expand

or warp. Heat dissipation zones are disrupted, overheating and melting of the electrodes or even engine damage can occur.

Spark plug tightening torques

The required tightening torque depends on seat type, thread diameter and cylinder head material. Please take care of the tightening torques or angles, whenever these are printed on the packaging material!

1 Seat type

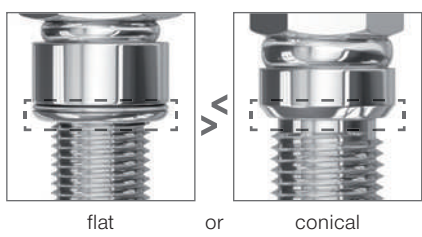

flat or conical

2 Thread diameter



3 Cylinder head material

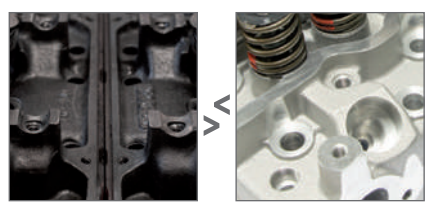

Cast iron or Aluminium

1	Seat type	Spark plug with a flat seat (with seal)				Spark plug with a conical seat	
	2 Thread Ø	10 mm	12 mm	14 mm	18 mm	12/14 mm	18 mm
3	Cast iron head	10-15 Nm	15-25 Nm	25-35 Nm	35-45 Nm	10-20 Nm	20-30 Nm
	Aluminium head	10-12 Nm	15-20 Nm	25-30 Nm	35-40 Nm	10-20 Nm	20-30 Nm

Alternative: Angle of rotation details

The respective angle of rotation can be found on the spark plug packaging. (Exception: racing plugs – only torque method)

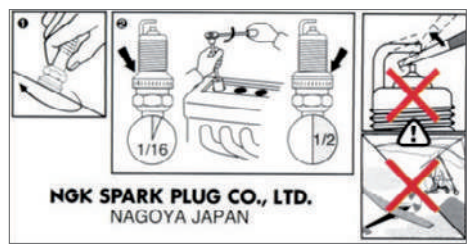



IMPORTANT TIPS FOR THE REMOVAL AND INSTALLATION OF GLOW PLUGS

1 Removal / Breakaway torque



Glow plug breakaway torque							
Ø Thread	Metal glow plugs				Ceramic glow plugs		
	M8	M9	M10	M12	M8	M9	M10
Breakaway torque	20 Nm	20 Nm	29 Nm	39 Nm	20 Nm	24 Nm	29 Nm

When changing glow plugs you must always use the correct torque, so that the breakaway torque is not exceeded, if not there is danger of tear-off.

Note: Other manufacturers often have, due to the varying thread materials, lower breakaway torque values. For this reason, you should reduce of a further 5 Nm the value, whenever the glow plug manufacturer is unknown.

2 Tips on removal issues

If an immediate removal is not urgent, we suggest proceeding as follows:

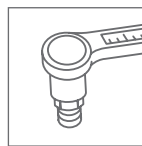
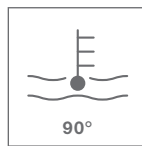
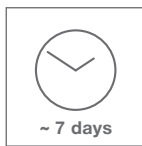

- > Sprinkle the glow plug seat on the transition to the cylinder head with synthetic motor oil.
- > Let absorb for a couple of days and move the vehicle.
- > Remove the glow plugs with the engine at operating temperature paying attention to the breakaway torques using a suitable torque wrench.

3 Cleaning

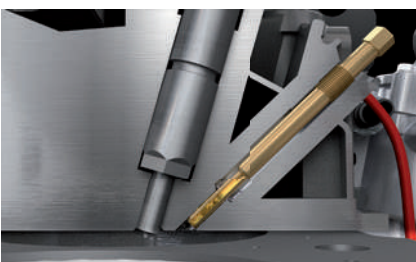

Before installing new glow plugs oil and soot residue should be removed from the glow plug hole with a greased reamer.

4 Glow plug installation / tightening torques

Metal glow plugs					Ceramic glow plugs			Connecting nut			
Ø Thread	M8	M9	M10	M10	M12	M8	M9	M10	Metal glow plugs		
Thread Pitch	-	-	1	1,25	-	-	-	-	Ø Thread	M4	M5
Tightening torque	8~15 Nm	8~15 Nm	10~15 Nm	15~20 Nm	20~25 Nm	9~12 Nm	13~16 Nm	15~20 Nm	Tightening torque	1.0~1.5 Nm	1.0~1.5 Nm

⚠ Please take care of the tightening torques, whenever these are printed on the packaging material! Glow plugs will function properly only when tightened with the correct tightening torque!





WICHTIGE TIPPS ZUM EINBAU VON ZÜNDKERZEN

Für die fachgerechte Montage einer Zündkerze ist ein Drehmomentschlüssel erforderlich. Denn selbst für Werkstattprofis ist das „Schätzen“ des Anzugsdrehmomentes nahezu unmöglich. Das liegt daran, dass sich ein Drehmoment aus zwei Größen errechnet, die miteinander multipliziert werden: der Kraft, die auf den jeweiligen Drehpunkt

einwirkt, und der Länge des Hebels. Die meisten Zündkerzenausfälle gehen auf ein falsches Anzugsdrehmoment zurück. Wird es zu niedrig gewählt, drohen Kompressionsverluste und Überhitzung. Auch ein Bruch von Isolator oder Mittelelektrode infolge von Vibrationen ist denkbar. Wird das Drehmoment zu hoch gewählt, kann es zum Abreißen

der Zündkerze führen. Auch kann das Gehäuse sich dehnen oder verdrehen. Die Wärmeabflusszonen werden gestört, es drohen Überhitzung und Verschmelzung der Elektroden bis hin zum Motorschaden.

Anzugsdrehmomente Zündkerzen

Das erforderliche Anzugsdrehmoment ist abhängig vom Sitztyp, Gewindedurchmesser und dem Zylinderkopfmaterial. Bitte beachten Sie die Anzugsdrehmomente oder -Winkel, wenn diese auf der Verpackung angegeben sind!

1 Sitztyp

flach oder konisch

2 Gewindedurchmesser

3 Zylinderkopfmaterial

Gusseisen oder Aluminium

1	Sitztyp	Zündkerze mit flachem Sitz (mit Dichtung)				Zündkerze mit konischem Sitz	
		10 mm	12 mm	14 mm	18 mm	12/14 mm	18 mm
3	Gusseisenkopf	10-15 Nm	15-25 Nm	25-35 Nm	35-45 Nm	10-20 Nm	20-30 Nm
	Aluminiumkopf	10-12 Nm	15-20 Nm	25-30 Nm	35-40 Nm	10-20 Nm	20-30 Nm

Alternativ: Drehwinkel-Angaben

Der jeweilige Drehwinkel ist auf der Zündkerzenverpackung zu finden. (Ausnahme: Rennzündkerzen - nur Drehmomentmethode)

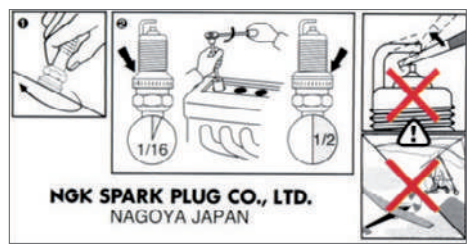



WICHTIGE TIPPS ZUM AUS- UND EINBAU VON GLÜHKERZEN

1 Ausbau / Abreissmomente



Glühkerzen Abreißmomente							
Ø Gewinde	Metallstabglühkerze				Keramische Glühkerze		
	M8	M9	M10	M12	M8	M9	M10
Abreißmomente	20 Nm	20 Nm	29 Nm	39 Nm	20 Nm	24 Nm	29 Nm

Beim Glühkerzenwechsel muss immer ein geeigneter Drehmomentschlüssel verwendet werden, damit das Abreissmoment nicht überschritten wird – ansonsten droht der Abriss.

Achtung: Andere Hersteller haben aufgrund unterschiedlicher Gewindematerialien oft geringere Abreißmomente. Daher sollten Sie den Wert um 5 Nm verringern, sofern der Glühkerzenhersteller nicht bekannt ist.

2 Tipps bei Ausbau-Problemen

Ist ein sofortiger Ausbau nicht dringend notwendig, empfehlen wir folgende Vorgehensweise:

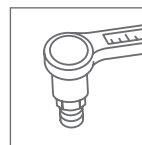
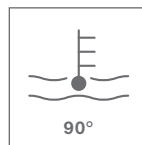

- > Glühkerzensitz am Übergang zum Zylinderkopf mit Synthetikmotoröl beträufeln.
- > Einige Tage einwirken lassen und Fahrzeug bewegen.
- > Glühkerze bei betriebswarmem Motor unter Beachtung der Abreißmomente mittels geeignetem Drehmomentschlüssel ausbauen.

3 Reinigung

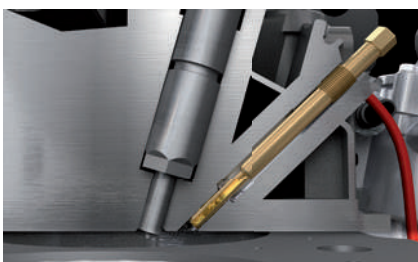

Vor dem Einbau neuer Glühkerzen sollten die Ölkohle- und Rußrückstände mit einer eingefetteten Reibahle aus der Glühkerzenbohrung entfernt werden.

4 Einbau / Anzugsdrehmomente Glühkerzen

Metallstabglühkerze					Keramische Glühkerze			Anschlussmutter			
Ø Gewinde	M8	M9	M10	M10	M12	M8	M9	M10	Metallstabglühkerze		
Gewindesteigung	-	-	1	1,25	-	-	-	-	Ø Gewinde	M4	M5
Anzugsdrehmoment	8~15 Nm	8~15 Nm	10~15 Nm	15~20 Nm	20~25 Nm	9~12 Nm	13~16 Nm	15~20 Nm	Anzugsdrehmoment	1.0~1.5 Nm	1.0~1.5 Nm

⚠ Bitte beachten Sie die Anzugsdrehmomente, sofern diese auf der Verpackung angegeben sind! Nur wenn Glühkerzen mit den richtigen Drehmomenten eingeschraubt werden, funktionieren sie einwandfrei!



CONSEILS IMPORTANTS POUR LE MONTAGE DE BOUGIES

Une clé dynamométrique est obligatoire pour monter correctement une bougie d'allumage. Même pour un réparateur confirmé, il est pratiquement impossible d'estimer précisément un couple de serrage. Le couple de serrage est à deux composantes : La force au point de rotation et la longueur du levier. Ce qui rend son estimation

difficile. La majorité des pannes liées aux bougies d'allumage sont dues à un couple de serrage incorrect. S'il est trop faible, la perte de compression peut générer une surchauffe et les vibrations peuvent créer une rupture de l'isolant ou de l'électrode centrale. A contrario, s'il est trop élevé, il peut provoquer un arrachage du filetage de

la bougie d'allumage. Le culot peut également se serrer dans la culasse. Les zones d'évacuation de chaleur peuvent se détruire, ce qui peut provoquer une surchauffe et une fonte des électrodes voire même une panne du moteur.

Couples de serrage des bougies

Le couple de serrage nécessaire dépend du type de siège, du diamètre du filetage et du matériau de culasse. Veuillez respecter les couples ou bien les angles de serrage lorsque ceux-ci sont indiqués sur l'emballage !

1 Type de siège

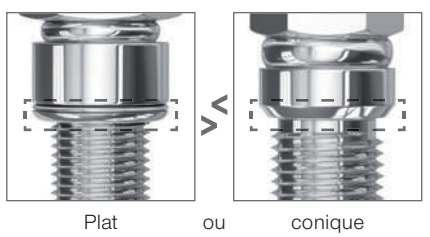

Plat ou conique

2 Diamètre du filetage



3 Matériau de la culasse

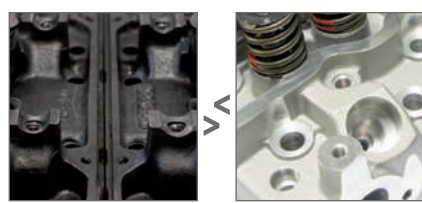

Fonte ou aluminium

1	Type de siège	Bougie avec siège plat (avec joint)				Bougie avec siège conique	
2	Ø du filetage	10 mm	12 mm	14 mm	18 mm	12/14 mm	18 mm
3	Culasse en fonte	10-15 Nm	15-25 Nm	25-35 Nm	35-45 Nm	10-20 Nm	20-30 Nm
	Culasse en aluminium	10-12 Nm	15-20 Nm	25-30 Nm	35-40 Nm	10-20 Nm	20-30 Nm

Alternative : indications d'angle de rotation (s'applique aux nouvelles bougies)

L'angle de serrage se trouve sur la boîte de la bougie d'allumage (Exception : bougies Racing - méthode du couple uniquement)

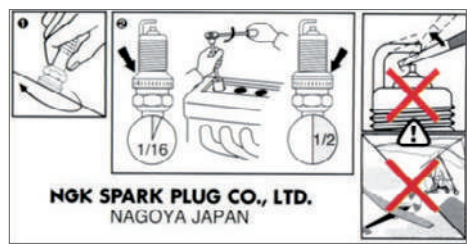



CONSEILS IMPORTANTS POUR LE MONTAGE ET LE DÉMONTAGE DE BOUGIES DE PRÉCHAUFFAGE

1 Démontage



Le démontage des bougies de préchauffage est souvent difficile et entraîne la casse de la bougie. Les couples de cisaillement (voir 2) ne doivent pas être dépassés lors du dévissage.

Couples de cisaillement							
Ø de filetage	Bougies de préchauffage métalliques				céramique		
	M8	M9	M10	M12	M8	M9	M10
Couples de cisaillement	20 Nm	20 Nm	29 Nm	39 Nm	20 Nm	24 Nm	29 Nm

Attention : d'autres fabricants, du fait de matériaux différents des filetages, ont souvent des couples de cisaillement plus faibles. C'est pour cette raison que vous devez réduire la valeur de 5 Nm si vous ne connaissez pas le fabricant de la bougie de préchauffage.

2 Conseils en cas de problème de démontage

Si un démontage immédiat n'est pas urgent, nous vous recommandons de suivre les étapes suivantes :

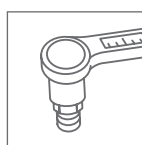
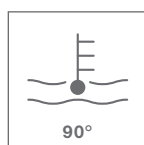

- > Arrosez le puits de la bougie de préchauffage avec de l'huile moteur synthétique.
- > Laissez agir quelques jours et déplacez le véhicule.
- > Démontez la bougie de préchauffage avec le moteur assez chaud pour son fonctionnement, en respectant les couples de cisaillement à l'aide de la clé dynamométrique adaptée.

3 Nettoyage

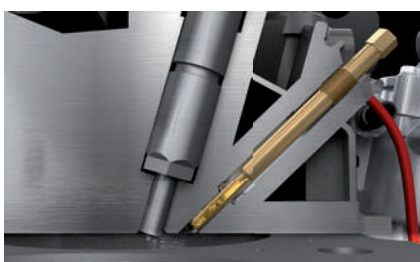

Avant le montage de nouvelles bougies de préchauffage, il faut que les résidus de calamine et de rouille soient retirés à l'aide d'un alésoir graissé pour les retirer de l'orifice de la bougie de préchauffage.

4 Couples de serrage des bougies de préchauffage

Bougies de préchauffage métalliques						céramique			Écrou de raccordement		
Ø de filetage	M8	M9	M10	M10	M12	M8	M9	M10	Bougies de préchauffage métalliques		
Pas de vis	-	-	1	1,25	-	-	-	-	Ø de filetage	M4	M5
Couple de serrage	8~15 Nm	8~15 Nm	10~15 Nm	15~20 Nm	20~25 Nm	9~12 Nm	13~16 Nm	15~20 Nm	Couple de serrage	1.0~1.5 Nm	1.0~1.5 Nm

⚠ Veuillez respecter les couples ou bien les angles de serrage dans la mesure où ceux-ci sont indiqués sur l'emballage ! Les bougies ne fonctionneront sans problème que si elles sont vissées avec le couple de serrage correct !





CONSIGLI IMPORTANTI PER L'INSTALLAZIONE DELLE CANDELE

Per installare a regola d'arte una candela di accensione è necessario utilizzare una chiave dinamometrica. La coppia di serraggio è data dal prodotto tra la forza applicata per il serraggio e la lunghezza del braccio della chiave (leva). Molti degli inconvenienti riscontrabili sulle candele sono riconducibili ad una coppia di

serraggio errata. Se la coppia risulta troppo bassa potrebbe verificarsi una rottura dell'isolatore o dell'elettrodo centrale in conseguenza delle vibrazioni. Se la coppia di serraggio risulta troppo elevata, il corpo metallico della candela potrebbe subire deformazioni a tal punto da compromettere l'efficienza dello scambio termico della candela.

Naturale conseguenza sono fenomeni di surriscaldamento e danni al motore.

Coppie di serraggio delle candele

La coppia di serraggio necessaria dipende dal tipo di sede, dal diametro del filetto e dal materiale della testata. Se le coppie o gli angoli di serraggio sono indicati sulla confezione, atteniti a quanto indicato!

1 Tipo di sede

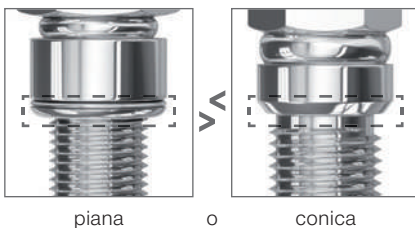

piana o conica

2 ø della filettatura



3 Materiale della testata

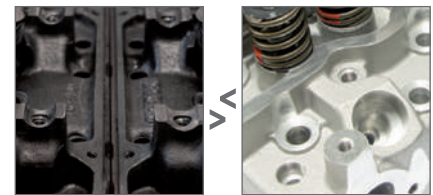

ghisa o alluminio

1	Tipo di sede	Candela a sede piana (con guarnizione)				sede conica	
2	ø della filettatura	10 mm	12 mm	14 mm	18 mm	12/14 mm	18 mm
3	Testata in ghisa	10-15 Nm	15-25 Nm	25-35 Nm	35-45 Nm	10-20 Nm	20-30 Nm
	Testata in alluminio	10-12 Nm	15-20 Nm	25-30 Nm	35-40 Nm	10-20 Nm	20-30 Nm

Alternativa: angolo di serraggio (validi per le candele nuove)

Il rispettivo angolo di rotazione può essere trovato sulla scatola della candela. (Eccezione: candele racing - indicata solo coppia di serraggio)

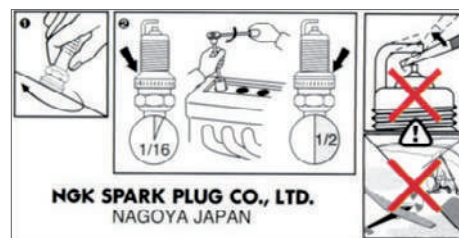

NGK SPARK PLUG CO., LTD.
NAGOYA JAPAN





CONSIGLI IMPORTANTI PER LA SOSTITUZIONE DELLE CANDELETTE

1 Smontaggio



Smontare le candele è spesso difficile e comporta il rischio di rottura. Non superare le coppie di rottura (vedere il punto 2) durante lo svitamento.

Coppie di rottura							
Ø della filettatura	Candele metallica				Candele ceramica		
	M8	M9	M10	M12	M8	M9	M10
Coppie di rottura	20 Nm	20 Nm	29 Nm	39 Nm	20 Nm	24 Nm	29 Nm

Attenzione: per via dei diversi materiali del filetto, altri produttori spesso prevedono coppie di rottura inferiori. Se il produttore delle candele non è noto, ridurre il valore di 5 Nm.

2 Consigli in caso di problemi di smontaggio

Se non si ha urgenza di procedere con lo smontaggio, consigliamo di procedere come indicato di seguito:

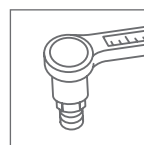
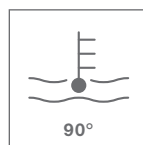

- > Versare dell'olio motore sintetico nel punto di contatto con la testata.
- > Lasciar agire per alcuni giorni utilizzando il veicolo.
- > Servendosi di una chiave dinamometrica adatta, smontare la candele con il motore alla temperatura di esercizio rispettando le coppie di rottura.

3 Pulizia

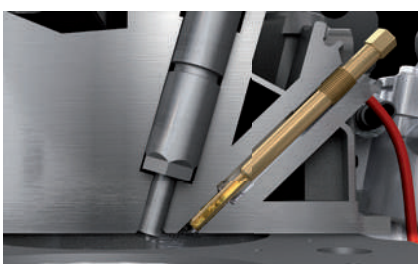

Prima di montare candele nuove, rimuovere i residui di olio carbonizzato e di fuliggine dal foro delle candele con un alesatore.

4 Coppie di serraggio delle candele

Candele metallica						Candele ceramica			Dado del terminale		
Ø della filettatura	M8	M9	M10	M10	M12	M8	M9	M10	Candele metallica		
Passo filettatura	-	-	1	1,25	-	-	-	-	Ø della filettatura	M4	M5
Coppia di serraggio	8~15 Nm	8~15 Nm	10~15 Nm	15~20 Nm	20~25 Nm	9~12 Nm	13~16 Nm	15~20 Nm	Coppia di serraggio	1.0~1.5 Nm	1.0~1.5 Nm



Se le coppie di serraggio sono indicate sulla confezione, atteniti a quanto indicato! Le candele funzionano perfettamente soltanto se sono installate con le coppie di serraggio corrette!





RECOMENDACIONES IMPORTANTES PARA EL MONTAJE DE LAS BUJÍAS

Pares de apriete para montar correctamente una bujía se necesita una llave dinamométrica, puesto que incluso para los técnicos profesionales de los talleres resulta casi imposible calcular el par de apriete correcto. Esto se debe a que los pares de apriete se calculan multiplicando dos dimensiones: la fuerza que se aplica sobre el punto de giro

correspondiente y la longitud de la palanca. La mayoría de los fallos que se producen en las bujías se deben a que el par de apriete es incorrecto. Si es demasiado bajo, las pérdidas de compresión podrían provocar un sobrecalentamiento. También se podría romper el aislador o el electrodo central a consecuencia de las vibraciones. Si el

par de apriete es demasiado alto, la bujía se podría romper. También la caja podría expandirse o torcerse. Las zonas de salida del calor se estropearían, los electrodos podrían sufrir sobrecalentamiento o fundirse y provocar una avería en el motor.

Pares de apriete de las bujías

El par de apriete necesario depende del tipo de asiento, el diámetro de la rosca y el material de la culata. Observe el par o el ángulo de apriete cuando estos se indiquen en el embalaje.

1 Tipo de asiento

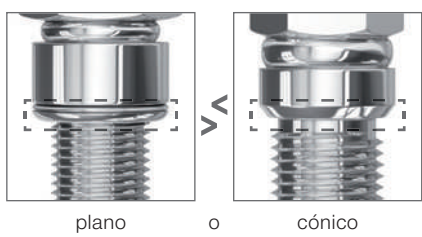

2 Diámetro de la rosca



3 Material de la culata

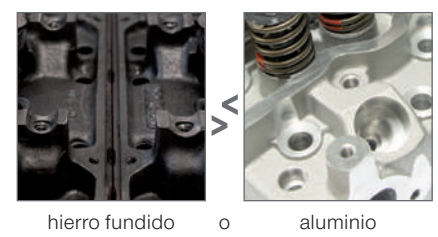

1	Tipo de asiento	Bujía con asiento plano (con junta)				Bujía con asiento cónico	
2	Ø de la rosca	10 mm	12 mm	14 mm	18 mm	12/14 mm	18 mm
3	Culata de hierro fundido	10-15 Nm	15-25 Nm	25-35 Nm	35-45 Nm	10-20 Nm	20-30 Nm
	Culata de aluminio	10-12 Nm	15-20 Nm	25-30 Nm	35-40 Nm	10-20 Nm	20-30 Nm

Alternativa: Datos del ángulo de apriete

El ángulo de rotación respectivo se puede encontrar en el embalaje de la bujía. (Excepción: pipas de competición: solo método de torsión)

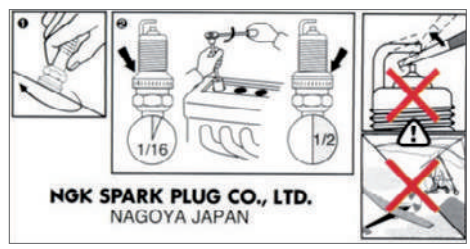



RECOMENDACIONES IMPORTANTES PARA EL DESMONTAJE Y EL MONTAJE DE LOS CALENTADORES

1 Pares de desmontaje/rotura



Para cambiar los calentadores se debe utilizar siempre una llave dinamométrica adecuada para no superar el par de rotura, porque de lo contrario existe el riesgo de que se rompan.

Pares de rotura de los calentadores

Ø de la rosca	Calentadores metálicos				Calentadores cerámicos		
	M8	M9	M10	M12	M8	M9	M10
Par de rotura	20 Nm	20 Nm	29 Nm	39 Nm	20 Nm	24 Nm	29 Nm

Advertencia: es frecuente que los pares de apriete de otros fabricantes sean menores porque utilizan otros materiales para la rosca. Por lo tanto, el valor debe reducirse 5 Nm si no se conoce el fabricante del calentador.

2 Recomendaciones para los problemas de desmontaje

Si no es necesario realizar el desmontaje de forma inmediata, le recomendamos lo siguiente:

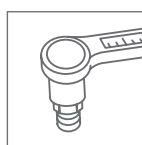
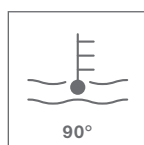

- > Impregnar con aceite de motor sintético el área de transición entre el asiento del calentador y la culata.
- > Dejarlo actuar unos días y mover el vehículo.
- > Desmontar el calentador con el motor a temperatura de funcionamiento y observando los pares de rotura con una llave dinamométrica adecuada.

3 Limpieza

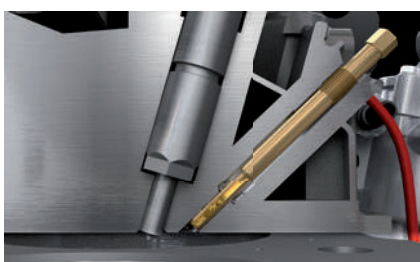

Antes de montar calentadores nuevos se deben retirar los restos de carbonilla y hollín con un escariador engrasado del orificio del calentador.

4 Montaje/pares de apriete de los calentadores

Calentadores metálicos					Calentadores cerámicos			Tuerca de unión			
Ø de la rosca	M8	M9	M10	M10	M12	M8	M9	M10	Calentadores metálicos		
Paso de rosca	-	-	1	1,25	-	-	-	-	Ø de la rosca	M4	M5
Par de apriete	8~15 Nm	8~15 Nm	10~15 Nm	15~20 Nm	20~25 Nm	9~12 Nm	13~16 Nm	15~20 Nm	Par de apriete	1.0~1.5 Nm	1.0~1.5 Nm

⚠ Observe el par de apriete cuando este se indique en el embalaje. Los calentadores solo funcionan correctamente cuando se enroscan con el par de apriete correcto.





BELANGRIJKE TIPS VOOR DE INBOUW VAN BOUGIES

Voor de vakkundige montage van een bougie is een draaimomentsleutel noodzakelijk. Want zelfs voor vakmensen uit een garage is het vrijwel onmogelijk om het aandraaimoment te schatten. Dat komt doordat een aandraaimoment berekend wordt door twee grootheden met elkaar te vermenigvuldigen: de kracht, die op het betreffende draaipunt

inwerkt en de lengte van de hendel. Als een bougie uitvalt, is een verkeerd aandraaimoment meestal de oorzaak hiervan. Als het aandraaimoment te laag is, bestaat gevaar voor compressieverlies en oververhitting. Ook is een breuk van de isolator of de middenelektrode denkbaar als gevolg van trillingen. Als het aandraaimoment

te hoog is, kan de bougie afbreken. Ook kan de behuizing uitzetten of zich verdraaien. De zones voor de warmteafleiding worden vernield, er bestaat gevaar voor oververhitting, samensmelten van de elektroden en zelfs motorschade.

Aandraaimomenten bougies

Het vereiste aandraaimoment is afhankelijk van de zitting, het schroefdraad diameter en het materiaal van de cilinderkop. Houd rekening met de aandraaimomenten of -hoeken als deze op de verpakking staan aangeduid!

1 Zitting

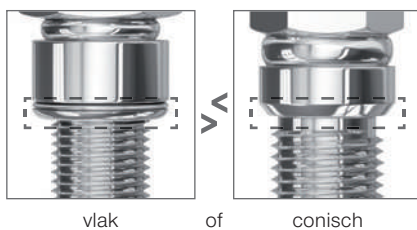

vlak of conisch

2 Schroefdraad diameter



3 Materiaal cilinderkop

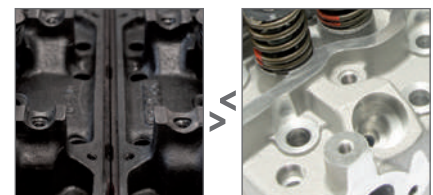

gietijzer of aluminium

1 Zitting	Bougie met vlakke zitting (met pakking)				Bougie met conische zitting		
2 Schroefdraad Ø	10 mm	12 mm	14 mm	18 mm	12/14 mm	18 mm	
3	gietijzeren kop	10-15 Nm	15-25 Nm	25-35 Nm	35-45 Nm	10-20 Nm	20-30 Nm
	aluminium kop	10-12 Nm	15-20 Nm	25-30 Nm	35-40 Nm	10-20 Nm	20-30 Nm

Alternatief: Specificaties voor verdraaiingshoek

De betreffende aanhaalhoek staat op de bougieverpakking. (Uitzondering: race bougies - alleen aanhaalmoment)

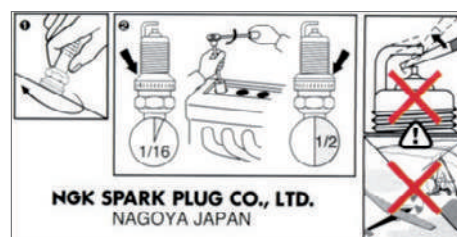



BELANGRIJKE TIPS VOOR INBOUWEN EN VERWIJDEREN VAN GLOEIBOUGIES

1 Demontage- / afbrekmomenten



Gloeibougies afbrekmomenten							
Ø schroefdraad	Metalen bougies				Keramische gloeibougies		
	M8	M9	M10	M12	M8	M9	M10
Afbreek-moment	20 Nm	20 Nm	29 Nm	39 Nm	20 Nm	24 Nm	29 Nm

Tijdens de vervanging van gloeibougies moet altijd een geschikte momentsleutel worden gebruikt, zodat het afbrekmoment niet wordt overschreden – met een mogelijke breuk als gevolg.

Let op: Andere fabrikanten hebben op basis van uiteenlopend schroefdraadmateriaal vaak lagere afbrekmomenten. Daarom adviseren wij u een waarde van 5 Nm minder te nemen, als de fabrikant van de gloeibougie onbekend is.

2 Tips voor als er problemen bij de verwijdering zijn

Als een onmiddellijke demontage niet dringend noodzakelijk is, raden wij de volgende aanpak aan:

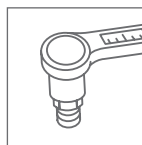
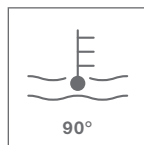

- > De zitting van de gloeibougie bij de overgang naar de cilinderkop met synthetische motorolie bedruppelen.
- > Enkele dagen laten inwerken en het voertuig gebruiken.
- > Gloeibougie bij warme motor met een geschikte momentsleutel demonteren, rekening houdend met het afbrekmoment.

3 Reiniging

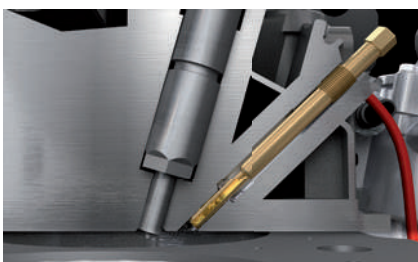

Voor de montage van nieuwe gloeibougies moeten de kool- en roetresten met een ingevette ruimer uit de gloeibougie-kanalen worden verwijderd.

4 Inbouw / aanhaalmoment gloeibougies

Metalen bougies						Keramische gloeibougies			Vleugelmoer		
Ø schroefdraad	M8	M9	M10	M10	M12	M8	M9	M10	Metalen bougies		
Spood	-	-	1	1,25	-	-	-	-	Ø schroefdraad	M4	M5
Aanhaal-moment	8~15 Nm	8~15 Nm	10~15 Nm	15~20 Nm	20~25 Nm	9~12 Nm	13~16 Nm	15~20 Nm	Aanhaal-moment	1.0~1.5 Nm	1.0~1.5 Nm

! Houd rekening met de aandraaimomenten voor zover deze op de verpakking staan aangeduid! Alleen wanneer gloeibougies met de juiste draaimomenten worden gemonteerd, functioneren ze probleemloos!





DICAS IMPORTANTES PARA A MONTAGEM DE VELAS DE IGNIÇÃO

O torque de aperto correcto para velas de ignição para a montagem correcta de uma vela de ignição é necessário usar uma chave dinamométrica. Porque mesmo o mecânico mais experiente é incapaz de “estimar” o torque de aperto. Isto se explica pelo fato do binário para ser calculado a partir de dois valores que são multiplicados: A força,

que actua no respectivo ponto rotativo, e o comprimento da alavanca. A maior parte das falhas das velas de ignição resultam de um torque de aperto errado. Se este for demasiado baixo, existe o risco de perdas de compressão e de sobreaquecimento. Também é possível que aconteça uma quebra do isolador ou do eléctrodo central por

causa das vibrações. Por outro lado, ao escolher um binário demasiado alto, isto pode levar à ruptura da vela de ignição. A carcaça além disso pode ficar dilatada ou distorcida. As zonas de dissipação de calor ficam danificadas, existe o risco de fundição dos eléctrodos e, inclusive, de gripar o motor.

Torques de aperto das velas de ignição

O torque de aperto necessário depende do tipo de assento, do diâmetro da rosca e do material do cabeçote do cilindro. Por favor observe os torques ou ângulos de aperto, caso os mesmos sejam indicados na embalagem!

1 Tipo de assento

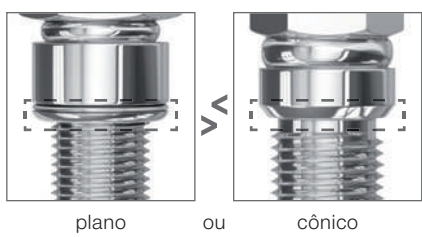

plano ou cônico

2 Diâmetro da rosca



3 Material do cabeçote do cilindro

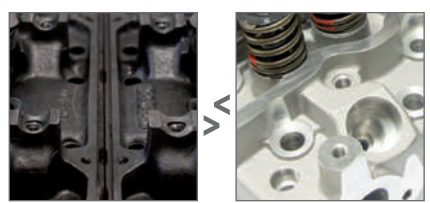

ferro fundido ou alumínio

1	Tipo de assento	Vela de ignição com assento plano (com gaxeta)				Vela de ignição com assento cônico	
		10 mm	12 mm	14 mm	18 mm	12/14 mm	18 mm
3	Cabeçote de ferro fundido	10-15 Nm	15-25 Nm	25-35 Nm	35-45 Nm	10-20 Nm	20-30 Nm
	Cabeçote de alumínio	10-12 Nm	15-20 Nm	25-30 Nm	35-40 Nm	10-20 Nm	20-30 Nm

Alternativa: Dados sobre o ângulo de rotação

O respectivo ângulo de rotação pode ser encontrado na embalagem da vela de ignição (exceção: cachimbo de competição: só método de torque)

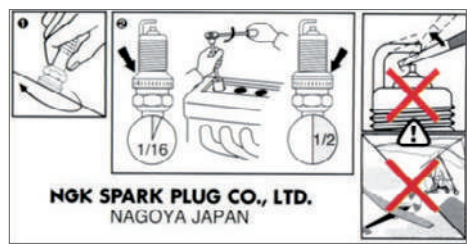



DICAS IMPORTANTES PARA A DESMONTAGEM E MONTAGEM DE VELAS AQUECEDORAS

1 Desmontagem / momentos de ruptura



Momentos de ruptura das velas aquecedoras							
Ø rosca	Vela aquecedora de haste metálica				Vela aquecedora cerâmica		
	M8	M9	M10	M12	M8	M9	M10
Momento de ruptura	20 Nm	20 Nm	29 Nm	39 Nm	20 Nm	24 Nm	29 Nm

Quando é feita a troca das velas aquecedoras é necessário usar sempre uma chave dinamométrica apropriada para evitar que o momento de ruptura seja ultrapassado, caso contrário, existe o perigo de uma ruptura.

Atenção: Os outros fabricantes têm frequentemente momentos de ruptura mais reduzidos devido a materiais de rosca diferentes. Por essa razão, você deve reduzir o valor em 5 Nm, se o fabricante da vela aquecedora não for conhecido.

2 Dicas em caso de problemas na desmontagem

Se não for necessário efetuar a desmontagem imediata, recomendamos o seguinte procedimento:

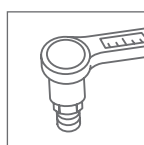
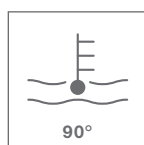

- > Salpicar o assento da vela aquecedora na passagem para o cabeçote do cilindro com óleo sintético para motores.
- > Deixar atuar durante alguns dias e movimentar o veículo.
- > Desmontar a vela aquecedora com motor quente, mediante uma chave dinamométrica apropriada, observando os momentos de ruptura.

3 Limpeza

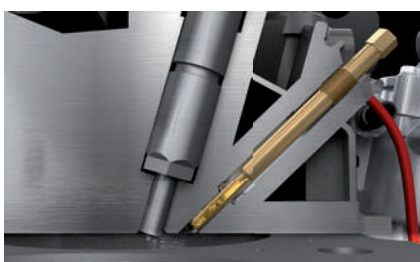

Antes de serem montadas novas velas aquecedoras, é necessário remover os resíduos de carvão de óleo e fuligem do furo das velas aquecedoras, mediante um alargador.

4 Montagem / torques de aperto das velas aquecedoras

Vela aquecedora de haste metálica						Vela aquecedora cerâmica			Porca de conexão		
Ø rosca	M8	M9	M10	M10	M12	M8	M9	M10	Vela aquecedora de haste metálica		
Passo da rosca	-	-	1	1,25	-	-	-	-	Ø rosca	M4	M5
Torque de aperto	8~15 Nm	8~15 Nm	10~15 Nm	15~20 Nm	20~25 Nm	9~12 Nm	13~16 Nm	15~20 Nm	Torque de aperto	1.0~1.5 Nm	1.0~1.5 Nm

! Por favor observe os torques de aperto, caso os mesmos sejam indicados na embalagem! As velas aquecedoras só funcionam perfeitamente, se as mesmas forem aparafusadas com o torque de aperto correto!





ΧΡΗΣΙΜΕΣ ΣΥΜΒΟΥΛΕΣ ΓΙΑ ΤΗΝ ΤΟΠΟΘΕΤΗΣΗ ΤΩΝ ΜΠΟΥΖΙ

Για την τοποθέτηση ενός μπουζί σύμφωνα με τους κανόνες, απαιτείται η χρήση ενός ροπόκλειδου. Ακόμη και για τους επαγγελματίες των συνεργείων η „εκτίμηση“ της ορθής ροπής σύσφιξης είναι σχεδόν αδύνατη. Αυτό έγκειται στο ότι η ροπή σύσφιξης υπολογίζεται από δύο μεγέθη, τα οποία πολλαπλασιάζονται μεταξύ τους: από τη δύναμη, η οποία

επενεργεί στο αντίστοιχο σημείο περιστροφής και το μήκος του μοχλού. Οι περισσότερες δυσλειτουργίες των μπουζί οφείλονται στη λανθασμένη ροπή σύσφιξης. Εάν επιλεγεί πολύ μικρή, υπάρχει ο κίνδυνος απώλειας συμπίεσης και υπερθέρμανσης. Είναι πιθανή, ακόμη και η ρήξη του μονωτήρα ή του κεντρικού ηλεκτροδίου, λόγω των κραδασμών.

Εφόσον η ροπή σύσφιξης είναι πολύ ψηλή, μπορεί να προκληθεί αποκοπή του μπουζί. Ακόμη ενδέχεται να διασταλεί το περίβλημα ή να συστραφεί. Οι ζώνες απαγωγής θερμότητας διαταράσσονται, παρουσιάζεται η απειλή υπερθέρμανσης και τήξης των ηλεκτροδίων, μέχρι και η πρόκληση ζημιάς στον κινητήρα.

Ροπή σύσφιξης μπουζί

Η απαιτούμενη ροπή σύσφιξης καθορίζεται από τον τύπο έδρας του μπουζί, τη διάμετρο του σπειρώματος και το υλικό της κυλινδροκεφαλής. Εάν στη συσκευασία αναγράφεται η ροπή ή η γωνία σύσφιξης, ακολουθήστε τις οδηγίες!

1 Τύπος έδρας

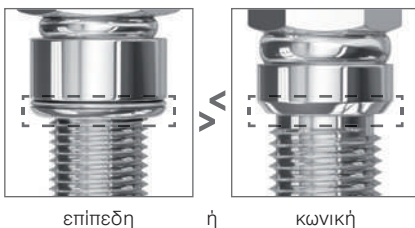

επίπεδη ή κωνική

2 Διάμετρος σπειρώματος



3 Υλικό κυλινδροκεφαλής

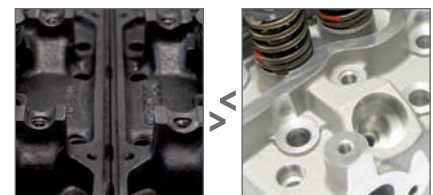

χυτοσίδηρος ή αλουμίνιο

1	Τύπος έδρας	Μπουζί με επίπεδη έδρα (με ροδέλα)				Μπουζί με κωνική έδρα	
2	Σπειρωμα Ø	10 mm	12 mm	14 mm	18 mm	12/14 mm	18 mm
3	κυλινδροκεφαλή από χυτοσίδηρο	10-15 Nm	15-25 Nm	25-35 Nm	35-45 Nm	10-20 Nm	20-30 Nm
	κυλινδροκεφαλή από αλουμίνιο	10-12 Nm	15-20 Nm	25-30 Nm	35-40 Nm	10-20 Nm	20-30 Nm

Εναλλακτικά: Γωνία σύσφιξης-στοιχεία

Η αντίστοιχη γωνία περιστροφής μπορεί να βρεθεί στη συσκευασία μπουζί. (Εξαιρέση: αγώνιστικά μπουζί - ροπόκλειδο μόνο)

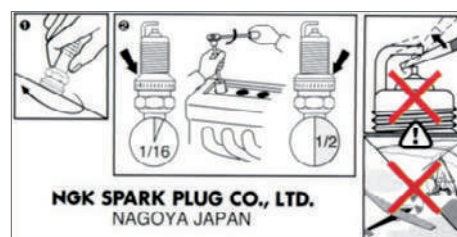

NGK SPARK PLUG CO., LTD.
NAGOYA JAPAN





ΧΡΗΣΙΜΕΣ ΣΥΜΒΟΥΛΕΣ ΓΙΑ ΤΗΝ ΑΦΑΙΡΕΣΗ ΚΑΙ ΤΗΝ ΤΟΠΟΘΕΤΗΣΗ ΤΩΝ ΠΡΟΘΕΡΜΑΝΤΗΡΩΝ

1 Αφαίρεση / Ροπή θραύσης



Προθερμαντήρες - Ροπή θραύσης							
Ø Σπειρώμα	Μεταλλικοί προθερμαντήρες				Κεραμικοί προθερμαντήρες		
	M8	M9	M10	M12	M8	M9	M10
Ροπή θραύσης	20 Nm	20 Nm	29 Nm	39 Nm	20 Nm	24 Nm	29 Nm

Κατά την αλλαγή των προθερμαντήρων είναι απαραίτητη η χρήση του κατάλληλου ροπόκλειδου για την αποφυγή της θραύσης τους.

Προσοχή: Άλλοι κατασκευαστές διαθέτουν μικρότερες ροπές θραύσης λόγω των διαφορετικών υλικών των σπειρωμάτων. Σε περίπτωση που ο κατασκευαστής δεν είναι γνωστός, μειώστε τη ροπή σύσφιξης κατά 5 Nm.

2 Συμβουλές για την αποφυγή προβλημάτων κατά την αφαίρεση

Εάν δεν απαιτείται άμεση αφαίρεση, συνιστάται η ακόλουθη διαδικασία:

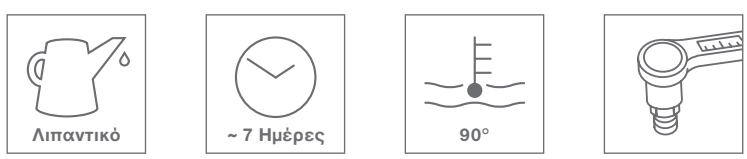

- > Λίπανση με συνθετικό λιπαντικό στο σημείο μεταξύ της βάσεως του προθερμαντήρα και της κυλινδροκεφαλής.
- > Αφήστε να δράσει μερικές μέρες κυκλοφορώντας το αυτοκίνητο.
- > Αφαιρέστε τον προθερμαντήρα με κατάλληλο ροπόκλειδο και την κατάλληλη ροπή εφόσον ο κινητήρας έχει προθερμανθεί.

3 Καθαρισμός

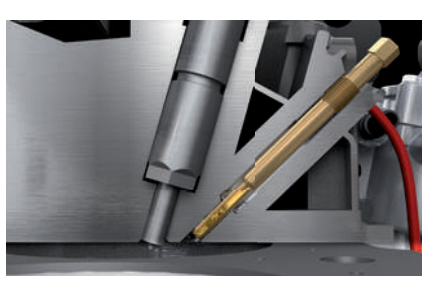

Πριν την τοποθέτηση νέων προθερμαντήρων αφαιρέστε με τη βοήθεια ενός ειδικού αλεζουάρ τα υπολείμματα λιπαντικού και αιθάλης από την οπή του προθερμαντήρα.

4 Τοποθέτηση / Ροπή σύσφιξης προθερμαντήρων

Μεταλλικοί προθερμαντήρες						Κεραμικοί προθερμαντήρες			παξιμάδι ακροδέκτη		
Ø Σπειρώμα	M8	M9	M10	M10	M12	M8	M9	M10	Μεταλλικοί προθερμαντήρες		
Βήμα σπειρώματος	-	-	1	1,25	-	-	-	-	Ø Σπειρώμα	M4	M5
Ροπή σύσφιξης	8~15 Nm	8~15 Nm	10~15 Nm	15~20 Nm	20~25 Nm	9~12 Nm	13~16 Nm	15~20 Nm	Ροπή σύσφιξης	1.0~1.5 Nm	1.0~1.5 Nm

! Εάν στη συσκευασία αναγράφεται η ροπή σύσφιξης, ακολουθήστε τις οδηγίες! Μόνο εφόσον χρησιμοποιηθεί η σωστή ροπή σύσφιξης, οι προθερμαντήρες λειτουργούν άψογα!





ATEŞLEME BUJİLERİNİN KURULUMU İÇİN ÖNEMLİ İPUÇLARI

Bir bujinin usule uygun montajı için ayarlı tork anahtarı gereklidir. Çünkü usta oto servisçiler için bile sıkma torkunu tahmin etmek neredeyse imkansızdır. Bunun nedeni, sıkma torkunun birbirleriyle çarpılan iki parametreden hesaplanmasıdır: ilgili döndürme noktasına etki eden kuvvet ve manivela kolunun uzunluğu. Buji

arızalarının çoğu yanlış sıkma torkundan kaynaklanır. Sıkma torku fazla küçük seçilirse sıkışma kayıpları ve aşırı hararet tehlikesi vardır. Ayrıca titreşimler sonucunda izolatörün ya da orta elektrodun kırılması da akla gelebilecek ihtimallerdir. Sıkma torku fazla büyük seçilirse, bu durum bujinin kopmasına yol açabilir. Ayrıca gövde genleşebilir

ya da burulabilir. Isı iletim bölgeleri zedelenir, aşırı hararet ve elektrotların erimesi ve hatta motorun hasar görmesi tehlikesi vardır.

Kızdırma bujisi sıkma torqları

Gerekten sıkma torku; oturma türüne, dış çapına ve silindir başlığının malzemesine bağlıdır. Ambalajın üzerinde yazıyorsa lütfen sıkma torqlarına veya açılara dikkat edin!

1 Oturma Tipi

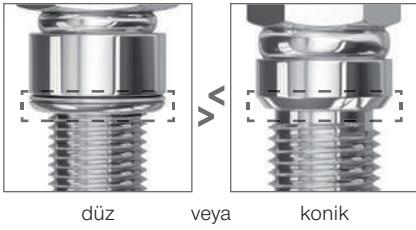

düz veya konik

2 Dış çapı



3 Silindir başlığı malzemesi

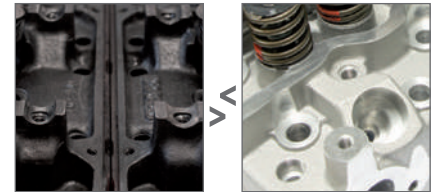

Dökme demir veya Alüminyum

1	Oturma tipi	Düz yataklı ateşleme bujisi (contalı)				Konik yataklı ateşleme bujisi	
		10 mm	12 mm	14 mm	18 mm	12/14 mm	18 mm
3	Dökme demir başlığı	10-15 Nm	15-25 Nm	25-35 Nm	35-45 Nm	10-20 Nm	20-30 Nm
	Alüminyum başlık	10-12 Nm	15-20 Nm	25-30 Nm	35-40 Nm	10-20 Nm	20-30 Nm

Alternatif: Dönüş açısı ayrıntıları

İlgili dönme açısı buji ambalajı üzerinde bulunmaktadır. (İstisna: yarış bujileri - sadece tork yöntemi)

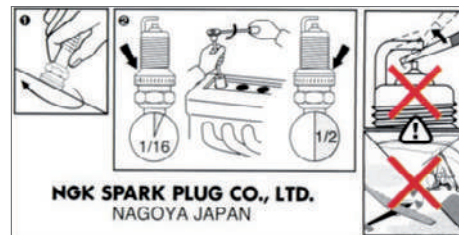



KIZDIRMA BUJİLERİNİN SÖKMEK VE TAKMAK İÇİN ÖNEMLİ İPUÇLARI

1 Sökme / Kopma Torqu



Kızdırma bujisi kopma torqu							
Dis Ø	Metal çubuklu kızdırma bujileri				Seramik kızdırma bujileri		
	M8	M9	M10	M12	M8	M9	M10
Kopma torqu	20 Nm	20 Nm	29 Nm	39 Nm	20 Nm	24 Nm	29 Nm

Kızdırma bujilerini değiştirirken kopma torqu aşılmayacak biçimde daima doğru torqu kullanmanız gerekir. Aksi takdirde parçanın kopup fırlama tehlikesi vardır.

Not: Diğer üreticilerin değişen diş malzemelerinden dolayı daha düşük kopma torquları vardır. Bu nedenle, kızdırma bujisi üreticisi bilinmiyorsa değeri 5 Nm daha düşürmeniz gerekir.

2 Sökme sorunlarıyla ilgili ipuçları

Hemen sökme aciliyetiniz yoksa, şu şekilde devam etmenizi öneririz:

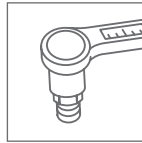
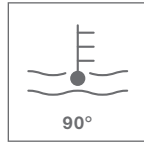

- > Kızdırma bujisi yatağının silindir başlığına geçtiği yere sentetik motor yağı püskürtün.
- > Birkaç gün bu yağı emmesini bekleyin ve aracı sürün.
- > Kızdırma bujilerini motorun çalışma sıcaklığında uygun bir torqu anahtarı kullanarak sökün. Kopma torquna dikkat edin.

3 Temizleme

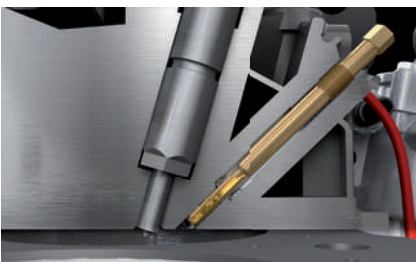

Yeni kızdırma bujilerini takmadan önce yağ ve kurum atıkları yağlı bir rayba kullanılarak kızdırma bujisi deliğinden temizlenmelidir.

4 Kızdırma bujisini takma / sıkma torquları

Metal çubuklu kızdırma bujileri					Seramik kızdırma bujileri			Bağlantı somunu			
Dis Ø	M8	M9	M10	M10	M12	M8	M9	M10	Metal çubuklu kızdırma bujileri		
Disli egimi	-	-	1	1,25	-	-	-	-	Dis Ø	M4	M5
Sıkma torqu	8~15 Nm	8~15 Nm	10~15 Nm	15~20 Nm	20~25 Nm	9~12 Nm	13~16 Nm	15~20 Nm	Sıkma torqu	1.0~1.5 Nm	1.0~1.5 Nm



Ambalajın üzerinde yazıyorsa lütfen sıkma torqularına dikkat edin! Kızdırma bujileri yalnızca sıkma torquları doğru olduğunda düzgün çalışır!





WAŻNE WSKAZÓWKI DOTYCZĄCE MONTAŻU ŚWIEC ZAPŁONOWYCH

Momenty dokręcenia: Do fachowego montażu świecy zapłonowej konieczny jest klucz dynamometryczny, ponieważ nawet sami mechanicy nie są w stanie dokładnie określić momentu dokręcenia. Wynika to z tego, że moment dokręcenia oblicza się mnożąc przez siebie dwie wielkości: siłę, która działa w danym punkcie obrotu

oraz długość dźwigni. Większość uszkodzeń świec zapłonowych spowodowanych jest błędnym momentem dokręcenia. Jeśli wybierze się zbyt mały moment dokręcenia, może nastąpić utrata sprężenia i przegrzanie. Możliwe jest również pęknięcie izolatora lub elektrody środkowej na skutek drgań. Jeśli

moment dokręcenia będzie za duży, może dojść do zerwania świecy zapłonowej. Także korpus nie będzie mógł się rozciągnąć ani przekręcić. Strefy odpływu ciepła będą zakłócone, a wtedy istnieje niebezpieczeństwo przegrzania i stopienia elektrod aż do uszkodzenia silnika.

Momenty dokręcenia świec zapłonowych

Wymagany moment dokręcenia zależy od typu gniazda, średnicy gwintu oraz materiału głowicy cylindrowej. Należy przestrzegać momentów lub kątów dokręcenia, jeśli są one podane na opakowaniu!

1 Typ gniazda

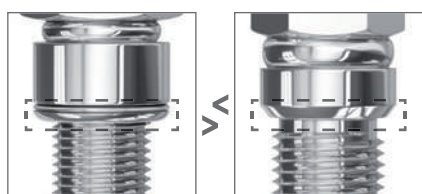

płaskie lub stożkowe

2 Średnica gwintu



3 Materiał głowicy cylindrowej

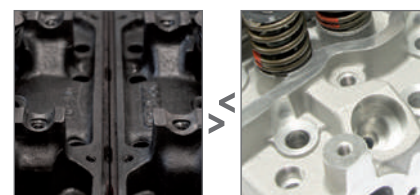

żeliwo lub aluminium

1	Typ gniazda	Świeca zapłonowa z płaskim gniazdem (z uszczelką)				Świeca zapłonowa ze stożkowym gniazdem	
		10 mm	12 mm	14 mm	18 mm	12/14 mm	18 mm
3	głowica żeliwna	10-15 Nm	15-25 Nm	25-35 Nm	35-45 Nm	10-20 Nm	20-30 Nm
	głowica aluminiowa	10-12 Nm	15-20 Nm	25-30 Nm	35-40 Nm	10-20 Nm	20-30 Nm

Alternatywnie: Dane dotyczące momentu dokręcenia

Odpowiedni kąt dokręcania podany jest na opakowaniu świecy zapłonowej (wyjątek: świece sportowe - tylko momenty dokręcania)

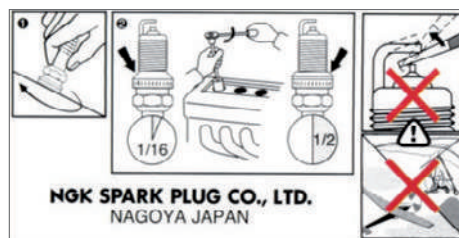



WAŻNE WSKAZÓWKI DOTYCZĄCE DEMONTAŻU I MONTAŻU ŚWIEC ŻAROWYCH

1 Demontaż / momenty zerwania



Momenty dokręcenia świec żarowych							
Średnica gwintu	Świece żarowe z metalowym prętym				Ceramiczne świece żarowe		
	M8	M9	M10	M12	M8	M9	M10
Moment gnący	20 Nm	20 Nm	29 Nm	39 Nm	20 Nm	24 Nm	29 Nm

Podczas wymiany świec żarowych zawsze należy stosować odpowiedni klucz dynamometryczny, aby uniknąć przekroczenia momentu dokręcenia – w przeciwnym razie może dojść do zerwania świecy.

Uwaga: Ze względu na użycie różnych materiałów gwintu, wielu producentów często wyznacza niższe momenty dokręcenia. Jeśli producent świec żarowych nie jest znany, należy zastosować wartość niższą o 5 Nm.

2 Wskazówki zapobiegające problemom z demontażem

Jeśli natychmiastowy demontaż nie jest pilnie wymagany, zalecamy następujący sposób postępowania:

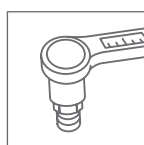
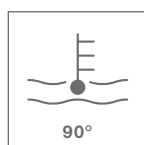

- > Gniazdo świecy żarowej w miejscu przejścia do głowicy cylindrowej posmarować syntetycznym olejem silnikowym.
- > Odczekać kilka dni i przejechać się samochodem.
- > Świecę żarową zdemontować przy pomocy odpowiedniego klucza dynamometrycznego wtedy, gdy silnik jest rozgrzany, z uwzględnieniem momentów dokręcenia.

3 Czyszczenie



Przed montażem nowych świec żarowych należy usunąć z otworów na świece żarowe pozostałości nagaru olejowego i sadzy przy pomocy naoliwionego rozwiertaka.

4 Montaż / momenty dokręcenia świec żarowych

Średnica gwintu	Świece żarowe z metalowym prętym					Ceramiczne świece żarowe			Nakrętka złączowa		
	M8	M9	M10	M10	M12	M8	M9	M10	Świece żarowe z metalowym prętym		
Skok gwintu	-	-	1	1,25	-	-	-	-	Średnica gwintu	M4	M5
Moment dokręcenia	8~15 Nm	8~15 Nm	10~15 Nm	15~20 Nm	20~25 Nm	9~12 Nm	13~16 Nm	15~20 Nm	Moment dokręcenia	1.0~1.5 Nm	1.0~1.5 Nm

! Należy przestrzegać momentów dokręcenia, jeśli są one podane na opakowaniu! Świece żarowe działają prawidłowo tylko wtedy, gdy są wkręcone z uwzględnieniem odpowiednich momentów dokręcenia!





DŮLEŽITÉ TIPY PRO INSTALACI ZAPALOVACÍCH SVÍČEK

Pro správnou montáž zapalovací svíčky je potřebný momentový klíč. Dokonce i pro profesionála ze servisu je totiž téměř nemožný „odhad“ utahovacího momentu. To je dáno tím, že utahovací moment se vypočítá ze dvou veličin, které se vzájemně násobí: síly, která v daném bodu otáčení působí, a délky páky. Většina výpadků zapalovacích svíček má

příčinu ve špatném utahovacím momentu. Pokud je příliš malý, hrozí ztráty komprese a přehřátí. V důsledku vibrací může dojít i k prasknutí izolátoru nebo střední elektrody. Pokud je utahovací moment příliš velký, může dojít k vytržení zapalovací svíčky. Také může dojít k protažení nebo deformaci korpusu. Dochází k přerušování zón odvodu tepla,

hrozí přehřátí a roztavení elektrod ba dokonce i poškození motoru.

Utahovací momenty zapalovacích svíček

Požadovaný utahovací moment závisí na typu sedla, průměru závitu a materiálu hlavy válce.

Vždy dodržujte utahovací momenty nebo úhly, pokud jsou vytištěné na obalu!

1 Typ sedla

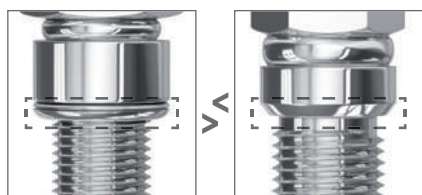

plochý nebo kuželový

2 Průměr závitu



3 Materiál hlavy válce

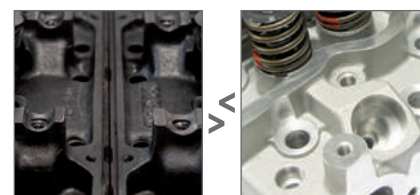

Litina nebo hliník

1	Typ sedla	Zapalovací svíčka s plochým sedlem (s těsněním)				Zapalovací svíčka s kuželovým sedlem	
		10 mm	12 mm	14 mm	18 mm	12/14 mm	18 mm
3	Litinová hlava	10-15 Nm	15-25 Nm	25-35 Nm	35-45 Nm	10-20 Nm	20-30 Nm
	Hliníková hlava	10-12 Nm	15-20 Nm	25-30 Nm	35-40 Nm	10-20 Nm	20-30 Nm

Jiné řešení: Podrobnosti ohledně úhlu otáčení

Příslušný úhel otáčení najdete na obalu zapalovací svíčky.

(Výjimka: závodní zapalovací svíčky – pouze metoda utahovacího momentu)

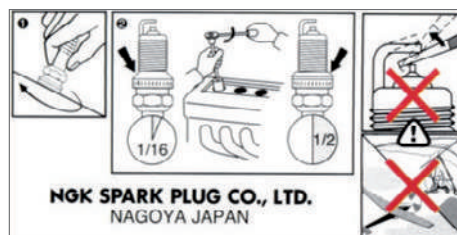



DŮLEŽITÉ TIPY PRO VYJMUTÍ A INSTALACI ŽHAVICÍCH SVÍČEK

1 Vyjmutí / Záběrný moment



Záběrný moment u žhavicí svíčky							
Ø závitu	Žhavicí svíčky s kovovou elektrodou				Keramické žhavicí svíčky		
	M8	M9	M10	M12	M8	M9	M10
Záběrný moment	20 Nm	20 Nm	29 Nm	39 Nm	20 Nm	24 Nm	29 Nm

Při výměně žhavicích svíček musíte vždy použít správný moment, abyste nepřekročili záběrný moment a neohrozilo nebezpečí utržení.

Poznámka: Jiní výrobci mají kvůli různým materiálům závitu často nižší hodnoty záběrného momentu. Z toho důvodu byste měli snížit jeho hodnotu o 5 Nm, kdykoli neznáte výrobce žhavicích svíček.

2 Tipy pro problémy s vyjímáním svíček

Není-li nutno svíčku okamžitě odstranit, doporučujeme postupovat následovně:

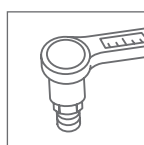
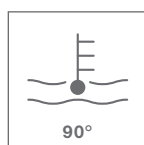

- > Nastříkejte syntetický motorový olej na sedlo žhavicí svíčky v místě přechodu do hlavy válce.
- > Nechte absorbovat několik dní a vozem pohybuje.
- > Vyjměte žhavicí svíčky za provozní teploty motoru a věnujte pozornost záběrnému momentu za použití vhodného momentového klíče.

3 Čištění

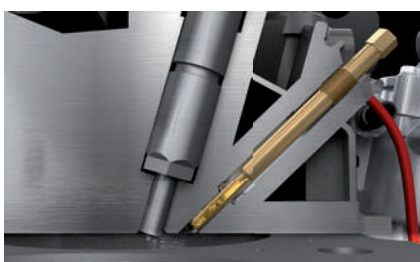

Před instalací nových žhavicích svíček odstraňte z otvoru žhavicí svíčky zbytky oleje a sazí pomocí promazaného výstružníku.

4 Instalace / utahovací momenty žhavicích svíček

Žhavicí svíčky s kovovou elektrodou					Keramické žhavicí svíčky			Spojovací matice			
Ø závitu	M8	M9	M10	M10	M12	M8	M9	M10	Žhavicí svíčky s kovovou elektrodou		
Rozteč	-	-	1	1,25	-	-	-	-	Ø závitu	M4	M5
Utahovací moment	8~15 Nm	8~15 Nm	10~15 Nm	15~20 Nm	20~25 Nm	9~12 Nm	13~16 Nm	15~20 Nm	Utahovací moment	1.0~1.5 Nm	1.0~1.5 Nm



Vždy dodržujte utahovací momenty nebo úhly, pokud jsou vytištěné na obalu! Žhavicí svíčky budou fungovat správně, pouze pokud jsou utaženy správným utahovacím momentem!





FONTOS BESZERELÉSI TANÁCSOK GYÚJTÓGYERTYÁK

A gyújtógyertya szakszerű beszereléséhez ajánlott a nyomatékkulcs használata. A meghúzási nyomaték megbecsülése még a profi szerelők számára is közel lehetetlen. Ez abból adódik, hogy a nyomaték két mennyiség szorzataként adódik: a mindenkori forgásponton

ható erő és az erőkar hossza. A legtöbb gyújtógyertya meghibásodást a hibás meghúzási nyomaték okozza. Ha túl alacsony, kompresszió veszteség és túlhevülés léphet fel. Előfordulhat a szigetelő vagy a középelektroda rezgés okozta törése is. Ha túl magas, a gyertya

elszakadhat. A ház is megnyúlhat ill. elcsavarodhat. Zavar keletkezik a hőelvezetés útjaiban, túlmelegedés és az elektrodák leolvadása fenyeget, ami motorhibát okozhat.

A gyújtógyertya meghúzási nyomatéka

A szükséges meghúzási nyomaték az ülék típusától, a menet átmérőjétől és a hengerfej anyagától függ. Kérjük ügyeljen a meghúzási nyomatékokra, illetve szögekre, amennyiben ezek a csomagoláson feltüntetésre kerültek!

1 A tömítés típusa

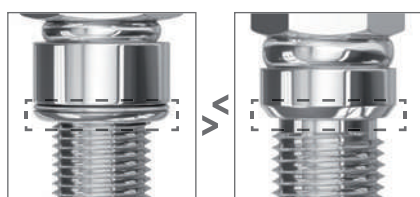

sík vagy kúpos

2 A menet átmérője



3 A hengerfej anyaga

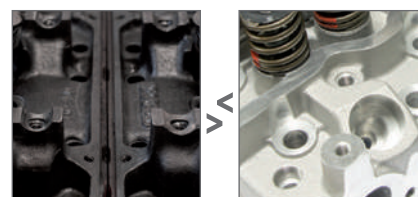

Öntöttvas vagy Alumínium

1	Az ülék típusa	Gyújtógyertya sík ülékkel (tömítéssel)				Gyújtógyertya kúpos ülékkel	
		10 mm	12 mm	14 mm	18 mm	12/14 mm	18 mm
3	Vasötvényből készült fej	10-15 Nm	15-25 Nm	25-35 Nm	35-45 Nm	10-20 Nm	20-30 Nm
	Könnyűfém (alumínium) fej	10-12 Nm	15-20 Nm	25-30 Nm	35-40 Nm	10-20 Nm	20-30 Nm

Alternatíva: Forgási szög részletek

A megfelelő forgásszög található a gyújtógyertya csomagolásán (Kivétel: verseny gyertyák - csak nyomaték módszer)

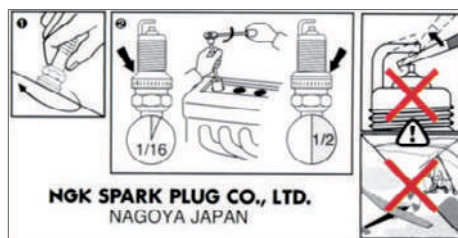



FONTOS ELTÁVOLÍTÁSI ÉS BESZERELÉSI TANÁCSOK IZZÍTÓGYERTYÁK

1 Lazítási / szakítási nyomaték



Gyújtógyertya törési nyomaték							
Ø Menet	Fémházas gyújtógyertyák				Kerámia gyújtógyertyák		
	M8	M9	M10	M12	M8	M9	M10
Törési nyomaték	20 Nm	20 Nm	29 Nm	39 Nm	20 Nm	24 Nm	29 Nm

Az izzítógyertyák eltávolításakor mindig a megfelelő nyomatékot használja, nehogy túllépje a nyírási nyomatékot, így nem kell a letöréstől tartania.

Megjegyzés: Más gyártók, mivel változó anyagú meneteket használnak, gyakran alacsonyabb szakítási nyomaték értékeket adnak meg. Ezért egy további, 5 Nm-rel még le kell csökkentenie ezt az értéket, ha nem ismeri az izzítógyertya gyártóját.

2 Tanácsok az eltávolításhoz

Ha az eltávolítás nem sürgős, javasoljuk, hogy a következők szerint járjon el:

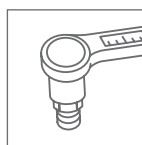
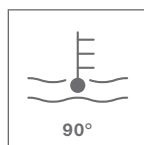
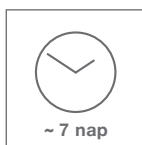

- > Spriccelje be az izzítógyertya ülekét a hengerfejnél szintetikus motorolajjal.
- > Hagyja egy pár napig, hogy az olaj beszívódjon, majd mozgassa meg a járművet.
- > Szerelje ki az izzítógyertyákat mialatt a motor még üzemi hőmérsékleten van ügyelve a törési nyomatékra és a megfelelő nyomaték-kulcsot használatával.

3 Tisztítás

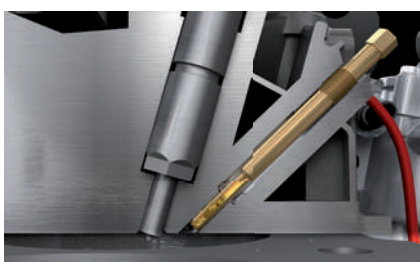

Az új izzítógyertyák beszerelése előtt el kell távolítani az olaj és korom lerakódásokat az izzítógyertya furatából egy beszírozott dörzsárral.

4 Gyújtógyertya beszerelési / meghúzási nyomatékok

Fémházas gyújtógyertyák						Kerámia gyújtógyertyák			Kerámia gyújtógyertyák		
Ø Menet	M8	M9	M10	M10	M12	M8	M9	M10	Fémházas gyújtógyertyák		
Menetemel- kedés	-	-	1	1,25	-	-	-	-	Ø Menet	M4	M5
Meghúzási nyomaték	8~15 Nm	8~15 Nm	10~15 Nm	15~20 Nm	20~25 Nm	9~12 Nm	13~16 Nm	15~20 Nm	Meghúzási nyomaték	1.0~1.5 Nm	1.0~1.5 Nm

⚠ Ügyeljen a meghúzási nyomatékokra, ha ezeket a csomagoláson feltüntették! Az izzítógyertyák csak akkor működnek megfelelően, ha a megfelelő meghúzási nyomatékkal rögzítik őket!





ВАЖНЫЕ СОВЕТЫ ПО УСТАНОВКЕ СВЕЧЕЙ ЗАЖИГАНИЯ

Момент затяжки. Для компетентного монтажа свечи зажигания требуется динамометрический ключ, поскольку даже для специалистов почти невозможно оценить момент затяжки. Это связано с тем, что крутящий момент состоит из двух величин, умножаемых друг на друга: силы, воздействующей на соответствующий

центр вращения и длины рукоятки. Большинство поломок свечей зажигания происходит из-за неправильного момента затяжки. Если он будет слишком низким, возникнут потери компрессии и перегрев. Из-за вибрации может также сломаться изолятор или средний электрод. Если крутящий

момент будет слишком высоким, свеча зажигания может оторваться. Также может расширяться или деформироваться корпус. Нарушаются зоны теплоотведения, что чревато перегревом и оплавлением электродов, вплоть до поломок двигателя.

Моменты затяжки свечей зажигания

Требуемый момент затяжки зависит от типа посадки, диаметра резьбы и материала головки блока цилиндров. Соблюдайте моменты или углы затяжки, если они указаны на упаковке!

1 Тип посадки

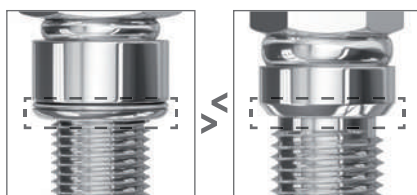

Плоская Или Коническая

2 Диаметр резьбы



3 Материал головки блока цилиндров

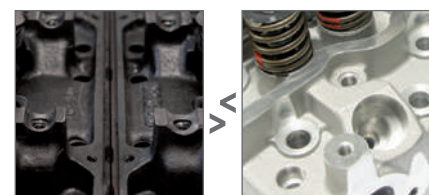

Чугун Или Алюминий

1	Тип посадки	Свеча зажигания с плоской посадкой (с уплотнительным кольцом)				Свеча зажигания с конической посадкой	
		10 мм	12 мм	14 мм	18 мм	12/14 мм	18 мм
3	Чугунная головка блока цилиндров	10-15 Нм	15-25 Нм	25-35 Нм	35-45 Нм	10-20 Нм	20-30 Нм
	Алюминиевая головка блока цилиндров	10-12 Нм	15-20 Нм	25-30 Нм	35-40 Нм	10-20 Нм	20-30 Нм

Альтернативно: Данные по углу доворота

Соответствующий угол затяжки указан на упаковке.
(Исключение: гоночные свечи - установка только с динамометрическим ключом)

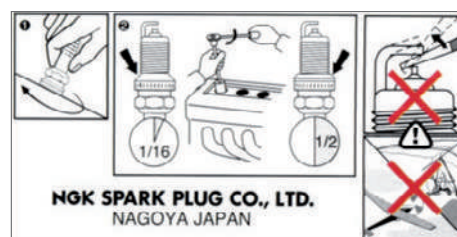



ВАЖНЫЕ УКАЗАНИЯ ПО СНЯТИЮ И УСТАНОВКЕ СВЕЧЕЙ НАКАЛИВАНИЯ

1 Снятие/моменты страгивания



Моменты поломки (среза) свечей накаливания							
Ø резьбы	Свеча накаливания с металлическим стержнем				Керамическая свеча накаливания		
	M8	M9	M10	M12	M8	M9	M10
Момент поломки (среза)	20 Нм	20 Нм	29 Нм	39 Нм	20 Нм	24 Нм	29 Нм

Для замены свечей накаливания всегда нужно использовать подходящий динамометрический ключ, чтобы не превысить момент поломки (среза); в противном случае свеча будет сломана.

Внимание: Продукция конкурентов из-за использования других материалов и технологий обычно имеет меньший момент поломки (среза). Поэтому, если изготовитель свечей накаливания неизвестен, то значение нужно уменьшить на 5 Нм.

2 Советы по решению проблем при демонтаже

Если нет срочной необходимости замены, то рекомендуется следующий порядок действий:

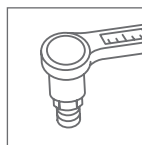
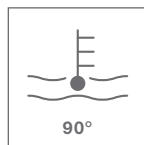
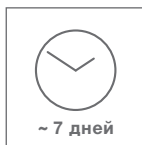

- > Смочить посадку свечи накаливания на переходе к ГБЦ синтетическим моторным маслом.
- > Оставить на несколько дней для просачивания масла в шахту свечи накаливания, эксплуатировать автомобиль как обычно.
- > Демонтировать свечу накаливания на прогревом до рабочей температуры двигателя с помощью подходящего динамометрического ключа.

3 Очистка

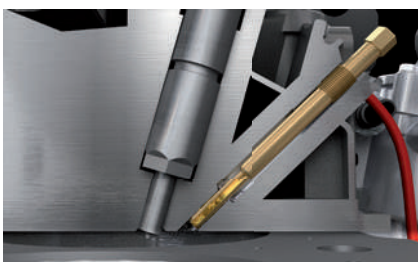

Перед установкой новых свечей накаливания с помощью римера (развертки), с нанесённой на него силиконовой смазки, нужно удалить остатки масляного нагара и сажи из шахты свечи накаливания.

4 Установка/моменты затяжки свечей накаливания

Свеча накаливания с металлическим стержнем						Керамическая свеча накаливания			Гайка терминала		
Ø резьбы	M8	M9	M10	M10	M12	M8	M9	M10	Свеча накаливания с металлическим стержнем		
Шаг резьбы	-	-	1	1,25	-	-	-	-	Ø резьбы	M4	M5
Момент затяжки	8~15 Нм	8~15 Нм	10~15 Нм	15~20 Нм	20~25 Нм	9~12 Нм	13~16 Нм	15~20 Нм	Момент затяжки	1.0~1.5 Нм	1.0~1.5 Нм

⚠ Соблюдайте моменты или углы затяжки, если они указаны на упаковке! Свечи накаливания работают безотказно, только если они ввернуты с правильным моментом затяжки!



QUALITY FROM THE WORLD LEADER. GLOW PLUGS. THE BASIC PRODUCT RANGE.



Yellow Box Line: the complete product range of leading manufacturers

In the Independent Aftermarket NGK SPARK PLUG follows frequently its serial production for e.g. BMW, VW, Citroen, Fiat, Ford, Mazda, Mercedes, Audi, Skoda, Renault, Nissan, Kia, Hyundai, Opel and Peugeot. The complete product range includes glow plugs for practically any diesel vehicle.



D-Power: fast moving items under the same roof

The D-Power fast moving product range covers the overall majority of the European car fleet. The product range includes many items following the OE proven technologies. Including NHTC and AQGS glow plugs.

SPARK PLUGS. THE BASIC PRODUCT RANGE.



Yellow Box Line: simply complete

The complete product range with many spark plugs following the OE business.



V-Line: the fast mover

The product range thanks to the high turnover rate and equally high returns achieves with 55 spark plugs a very high market coverage. The majority of the V-Line types follows the original equipment, among these many precious metal spark plugs.

HIGHER PERFORMANCE. MORE HIGH-TECH. SPARK PLUGS. THE SPECIAL SOLUTIONS.



Iridium IX: combined expertise

Spark Plugs with an extremely thin, laser welded central electrode and special technology against soot provoked ignition problems. To guarantee every time improved ignitability and lower fuel consumption. Due to its narrow central electrode it requires less ignition voltage and provides protection to the ignition coil. Iridium IX plugs are therefore also a perfect solution for many vintage cars.



Laser Platinum / Laser Iridium: the Premium spark plugs

The NGK SPARK PLUG precious metal Joker, offers absolute performance with low consumption. The ideal technology for modern engines. These spark plugs follow the OE business with the most important vehicle manufacturers.



LPG LaserLine: the product range for CNG / LPG

Eight double precious metal spark plugs specially developed for natural gas and LPG engines. The perfect choice for the majority of all conversion capable vehicles in Europe, with the proven NGK SPARK PLUG short numbering system for an efficient allocation and re-ordering.



NGK Racing: performance without compromise

Special spark plugs for high rev engines and extreme operating conditions. Many years of development of a world champion and official supplier of worldwide well-known motorsport teams.

QUALITÄT VOM WELTMARKTFÜHRER. GLÜHKERZEN. DIE BASIS-SORTIMENTE.



Yellow Box Line: das Komplettsortiment eines führenden Herstellers

Im freien Ersatzteilemarkt folgt NGK SPARK PLUG sehr häufig der Serienfertigung für u.a. BMW, VW, Citroen, Fiat, Ford, Mazda, Mercedes, Audi, Skoda, Renault, Nissan, Kia, Hyundai, Opel und Peugeot. Das Komplettsortiment enthält Glühkerzen für nahezu jedes Dieselfahrzeug.



D-Power: die Schnelldreher unter einem Dach

Das D-Power Schnelldreher Sortiment deckt die überwiegende Mehrheit des europäischen Fahrzeugbestandes ab. Das Sortiment folgt hierbei vielfach den OE bewährten Technologien. NHTC- und AQQS-Glühkerzen inklusive.

ZÜNDKERZEN. DIE BASIS-SORTIMENTE.



Yellow Box Line: einfach komplett

Das Komplett-Sortiment mit einer Vielzahl von Zündkerzen, die der Erstausrüstung folgen.



V-Line: der Schnelldreher

Das Sortiment für hohe Umschlagsgeschwindigkeit und ebensolche Rendite erzielt mit 55 Zündkerzen eine sehr hohe Marktabdeckung. Die Mehrheit der V-Line Typen stammt aus der Erstausrüstung, darunter viele Edelmetall-Zündkerzen.

MEHR LEISTUNG. MEHR HIGHTECH. ZÜNDKERZEN. DIE SPEZIALLÖSUNGEN.



Iridium IX: geballte Kompetenz

Zündkerzen mit extrem dünner, lasergeschweißter Mittelelektrode und Spezial-Technologie gegen verrußungsbedingte Zündprobleme. Für jederzeit optimales Start- und verbessertes Zündverhalten sowie geringerem Verbrauch. Dank der dünnen Mittelelektrode wird weniger Zündspannung benötigt, welches die Zündspule schont. Iridium IX Zündkerzen sind daher auch eine ideale Lösung für viele Oldtimer-Fahrzeuge.



Laser Platinum / Laser Iridium: die Premium-Zündkerze

Der Edelmetall-Joker von NGK SPARK PLUG. Für absolute Leistung bei sparsamem Verbrauch. Die ideale Technologie für moderne Motoren. Diese Zündkerzen folgen der Erstausrüstung mit den wichtigsten europäischen Fahrzeugherstellern.



LPG LaserLine: die Range für CNG / LPG

Acht eigens für Erdgas- und Flüssiggasmotoren entwickelte Doppel-Edelmetall-Zündkerzen. Die perfekte Wahl für die Mehrheit aller umrüstfähigen Fahrzeuge in Europa, mit bewährtem NGK Kurznummernsystem für effiziente Zuordnung und Nachbestellung.



NGK Racing: Leistung ohne Kompromisse

Spezial-Zündkerzen für hochdrehende Motoren und extreme Betriebsbedingungen. Viele Jahre Entwicklung mit einem Weltmeister und offizieller Ausrüster weltweit bekannter Motorsportteams.

QUALITÉ DU LEADER MONDIAL. BOUGIES DE PRÉCHAUFFAGE. LES GAMMES STANDARD.



Gamme Boîtes jaunes : la gamme complète des produits des principaux fabricants

Sur le marché indépendant des pièces de rechange, la bougie NGK SPARK PLUG suit fréquemment sa production en série pour, par exemple, BMW, VW, Citroën, Fiat, Ford, Mazda, Mercedes, Audi, Skoda, Renault, Nissan, Kia, Hyundai, Opel et Peugeot. La gamme complète de produits comprend des bougies de préchauffage pour presque tous les véhicules diesel.



D-Power : des articles à rotation rapide des stocks sous le même toit

La gamme de produits à rotation rapide des stocks D-Power couvre la majorité globale du parc automobile européen. La gamme de produits comprend de nombreux articles conformes aux technologies éprouvées de première monte. Comprend des bougies de préchauffage NHTC et AQGS.

BOUGIES D'ALLUMAGE. LES GAMMES STANDARD.



Gamme Boîtes jaunes : tout simplement complète

La gamme complète de produits avec de nombreuses bougies d'allumage qui suivent le secteur de première monte.



V-Line : la bougie à rotation rapide

La gamme de produits, grâce à un taux de rotation élevé et des rendements tout aussi élevés, atteint avec 55 bougies d'allumage une couverture de marché très élevée. La majorité des types V-Line suivent l'équipement d'origine, parmi lesquels de nombreuses bougies d'allumage en métal précieux.

PLUS DE PUISSANCE. PLUS DE HAUTE TECHNOLOGIE. BOUGIES D'ALLUMAGE. LES GAMMES SPECIALES.



Iridium IX : une expertise combinée

Bougies d'allumage avec une électrode centrale extrêmement fine, soudée au laser et une technologie spéciale contre les problèmes d'allumage provoqués par la suie. Pour garantir à chaque fois une meilleure inflammabilité et une consommation de carburant moins importante. Grâce à son électrode centrale étroite, elle nécessite moins de tension d'allumage et assure la protection de la bobine d'allumage. Les bougies Iridium IX sont donc également une solution parfaite pour de nombreuses voitures anciennes.



Laser Platinum / Laser Iridium : les bougies d'allumage Premium

La bougie NGK SPARK PLUG en métal précieux Joker, offre des performances absolues avec une faible consommation. La technologie idéale pour les moteurs modernes. Ces bougies d'allumage suivent le secteur de première monte avec les plus grands constructeurs automobiles.



LPG LaserLine : la gamme de produits pour le GNC / GPL

Huit bougies d'allumage doubles en métal précieux spécialement développées pour les moteurs au gaz naturel et au GPL. Le choix parfait pour la majorité de tous les véhicules pouvant être convertis en Europe, avec le système éprouvé de numérotation courte NGK SPARK PLUG qui facilite l'organisation et la commande de nouveaux articles.



NGK Racing : des performances sans compromis

Bougies d'allumage spéciales pour les moteurs à haut régime et les conditions de fonctionnement extrêmes. De nombreuses années de développement d'un champion du monde et fournisseur officiel d'équipes de sport automobile mondialement connues.

LA QUALITÀ DEL LEADER MONDIALE. CANDELETTE. GLI ASSORTIMENTI.



Linea con confezione gialla: la gamma completa di prodotti dei produttori leader del settore

Nell'aftermarket indipendente NGK SPARK PLUG segue frequentemente la sua produzione in serie, ad esempio per BMW, VW, Citroen, Fiat, Ford, Mazda, Mercedes, Audi, Skoda, Renault, Nissan, Kia, Hyundai, Opel e Peugeot. La gamma completa di prodotti comprende candele per praticamente qualsiasi veicolo diesel.



D-Power: articoli ad alta movimentazione sotto la stessa denominazione

La gamma di prodotti ad alta movimentazione D-Power copre la maggior parte del parco auto europeo. La gamma di prodotti comprende molti articoli che seguono le tecnologie collaudate OEM. Compresa le candele NHTC e AQGS.

CANDELE. GLI ASSORTIMENTI.



Linea con confezione gialla: semplicemente completa

La gamma completa di prodotti con numerose candele che seguono il segmento OEM.



Linea V: ad alta movimentazione

La gamma di prodotti grazie all'alto tasso di ricambio e ai rendimenti altrettanto alti raggiunge con 55 candele una copertura di mercato molto elevata. La maggior parte dei prodotti della V-Line segue l'equipaggiamento originale, tra questi molte candele in metallo prezioso.

PIÙ PERFORMANCE. PIÙ HIGH-TECH. CANDELE. LE SOLUZIONI SPECIALI.



Iridium IX: esperienza combinata

Candele con un elettrodo centrale estremamente sottile, con saldatura laser e una speciale tecnologia di contrasto ai problemi di accensione provocati dalla fuliggine. Per garantire ogni volta una migliore accensione e un minor consumo di carburante. Grazie al suo sottile elettrodo centrale, richiede una minore tensione di accensione e assicura la protezione alla bobina di accensione. Le candele Iridium IX sono quindi una soluzione perfetta anche per molte auto d'epoca.



Laser Platinum / Laser Iridium: le candele Premium

La candela NGK SPARK PLUG in metallo prezioso Joker, offre il massimo delle prestazioni con un basso consumo. La tecnologia ideale per i motori moderni. Queste candele seguono il segmento OEM con i più importanti produttori di veicoli.



LPG LaserLine: la gamma di prodotti per CNG / LPG

Otto candele doppie in metallo prezioso appositamente realizzate per i motori a metano e GPL. La scelta perfetta per la maggior parte dei veicoli che supportano l'installazione dell'alimentazione a gas in Europa, con il collaudato sistema di numerazione semplificato NGK SPARK PLUG per un'efficiente assegnazione e riordino.



NGK Racing: prestazioni senza compromessi

Candele speciali per motori ad alto numero di giri e condizioni operative estreme. Risultato di uno sviluppo pluriennale, campione del mondo e fornitore ufficiale di team di sport motoristici noti in tutto il mondo.

LA CALIDAD DEL LÍDER DEL MERCADO. CALENTADORES. LAS GAMAS BÁSICAS.



Yellow Box Line: la gama completa de productos de los principales fabricantes

En el mercado independiente de recambios, NGK SPARK PLUG se encarga de la producción en serie para, por ejemplo, BMW, VW, Citroen, Fiat, Ford, Mazda, Mercedes, Audi, Skoda, Renault, Nissan, Kia, Hyundai, Opel y Peugeot. La gama completa de productos incluye bujías de precalentamiento para prácticamente cualquier vehículo diésel.



D-Power: artículos de reposición rápida bajo el mismo techo

La gama de productos de reposición rápida D-Power cubre la mayor parte del parque automovilístico europeo. La gama de productos incluye muchos artículos que siguen las tecnologías probadas de los equipos originales. Incluidas las bujías de precalentamiento NHTC y AQGS.

BUJÍAS. LAS GAMAS BÁSICAS.



Yellow Box Line: simplemente completa

La gama completa de productos con una gran cantidad bujías de acuerdo con el negocio de los equipos originales.



V-Line: el motor rápido

Con 55 bujías, nuestra gama de productos logra una cobertura de mercado muy elevada gracias a la elevada tasa de rotación y a los rendimientos igualmente elevados. La mayoría de los tipos de V-Line siguen el equipamiento original, entre ellos muchas bujías de metales preciosos.

MEJOR RENDIMIENTO Y MEJOR TECNOLOGÍA. BUJÍAS. LAS SOLUCIONES TÉCNICAS ESPECIALES.



Iridium IX: experiencia combinada

Bujías con un electrodo central extremadamente fino, soldado con láser y con tecnología especial contra los problemas de encendido provocados por el hollín. Para garantizar siempre una mejor capacidad de encendido y un menor consumo de combustible. Debido a su estrecho electrodo central, requiere menos tensión de encendido y proporciona protección a la bobina de encendido. Por ello, las bujías Iridium IX son también una solución perfecta para muchos coches de época.



Laser Platinum / Laser Iridium: las bujías Premium

El metal precioso Joker de NGK SPARK PLUS ofrece un rendimiento máximo con un bajo consumo. La tecnología ideal para los motores modernos. Estas bujías siguen el negocio de equipos originales con los más importantes fabricantes de vehículos.



LPG LaserLine: la gama de productos para GNC / GLP

Ocho bujías dobles de metal precioso especialmente desarrolladas para motores de gas natural y GLP. La elección perfecta para la mayoría de los vehículos con capacidad de conversión en Europa, con el probado sistema de numeración corta de NGK SPARK PLUG para una eficiente asignación y realización de pedidos posteriores.



NGK Racing: rendimiento sin concesiones

Bujías especiales para motores de altas revoluciones y condiciones de funcionamiento extremas. Muchos años de desarrollo de un campeón mundial y proveedor oficial de equipos de automovilismo de renombre mundial.

KWALITEIT VAN DE WERELDWIJDE MARKTLEIDER. GLOEIBOUGIES. DE BASISASSORTIMENTEN.



Yellow Box Line: het complete productassortiment van toonaangevende fabrikanten

Op de onafhankelijke aftermarket volgt NGK SPARK PLUG regelmatig de standaardproductie voor bijv. BMW, VW, Citroen, Fiat, Ford, Mazda, Mercedes, Audi, Skoda, Renault, Nissan, Kia, Hyundai, Opel en Peugeot. Het complete productassortiment bestaat uit gloeibougies voor bijna elk dieselveertuig.



D-Power: goed verkopende artikelen onder één dak

Het goed verkopende D-Power-productassortiment is geschikt voor het merendeel van het Europese wagenpark. Het productassortiment bevat veel artikelen met OE-beproefde technologieën. Inclusief NHTC- en AQGS-gloeibougies.

BOUGIES. DE BASISASSORTIMENTEN.



Yellow Box Line: eenvoudigweg compleet

Het complete productassortiment met vele gloeibougies die de OE-bedrijven volgen.



V-Line: het goed verkopende productassortiment

Dankzij een hoge omloopsnelheid en hoge opbrengst behaalt het productassortiment met 55 ontstekingsbougies een zeer hoge marktdekking. Het merendeel van de V-Line-types volgt de originele uitrusting, waaronder veel hoogwaardige metalen ontstekingsbougies.

GROTERE PRESTATIE. MEER HIGHTECH. BOUGIES. SPECIALE OPLOSSINGEN.



Iridium IX: gecombineerde expertise

Ontstekingsbougies met een extreem dunne, lasergelaste centrale elektrode en speciale technologie om door roet veroorzaakte problemen tegen te gaan. Om telkens weer verbeterde ontsteekbaarheid en lager brandstofverbruik te garanderen. Vanwege de smalle centrale elektrode hebben ze minder ontstekingsspanning nodig en bieden ze bescherming voor de ontstekingsspoel. Iridium IX bougies zijn daarom een ideale oplossing voor veel vintage auto's.



Laser Platinum / Laser Iridium: de premium ontstekingsbougies

De hoogwaardige metalen Joker van NGK SPARK PLUG biedt absolute prestaties met laag verbruik. De ideale technologie voor moderne motoren. Deze gloeibougies volgen de OE-business met de belangrijkste voertuigfabrikanten.



LPG LaserLine: het productassortiment voor CNG / LPG

Acht dubbele hoogwaardige metalen gloeibougies speciaal ontwikkeld voor aardgas- en lpg-motoren. De perfecte keuze voor het merendeel van alle voor conversie geschikte voertuigen in Europa, met het beproefde korte nummeringsysteem van NGK SPARK PLUG voor efficiënte toewijzing en herhalingsbestelling.



NGK Racing: compromisloze prestaties

Speciale ontstekingsbougies voor krachtige motoren en extreme bedrijfsomstandigheden. Vele jaren van ontwikkeling van een wereldkampioen en officiële leverancier van bekende raceteams.

QUALIDADE DO LÍDER NO MERCADO MUNDIAL. VELAS AQUECEDORAS. AS GAMAS BASE.



Linha Caixa Amarela: a gama de produtos completa dos principais fabricantes

No mercado independente de reposição, a NGK SPARK PLUG segue frequentemente a sua produção em série para, p. ex., a BMW, VW, Citroen, Fiat, Ford, Mazda, Mercedes, Audi, Skoda, Renault, Nissan, Kia, Hyundai, Opel e Peugeot. A gama completa de produtos inclui velas de incandescência para praticamente todos os veículos diesel.



D-Power: artigos de alta rotatividade sob o mesmo teto

A gama de produtos D-Power de elevada rotatividade abrange a grande maioria da frota automóvel europeia. A gama de produtos inclui muitos artigos produzidos em conformidade com as tecnologias comprovadas do equipamento original. Incluindo as velas de incandescência NHTC e AQGS.

VELAS DE IGNIÇÃO. AS GAMAS BASE.



Linha Caixa Amarela: simplesmente completa

A gama de produtos completa com muitas velas de ignição na sequência do negócio de peças de equipamento original.



V-Line: o produto de alta rotatividade

Graças à elevada rotatividade e aos elevados retornos alcançados, a gama de produtos, que inclui 55 velas de ignição, garante uma cobertura de mercado muito elevada. A maioria dos tipos V-Line seguem o equipamento original, entre os quais muitas velas de ignição de metais preciosos.

MAIOR DESEMPENHO. MAIS HIGHTECH. VELAS DE IGNIÇÃO. AS SOLUÇÕES ESPECIAIS.



Iridium IX: especialização combinada

Velas de ignição com um eléctrodo central extremamente fino, soldado a laser e tecnologia especial contra problemas de ignição provocados pela fuligem. Para garantir sempre a melhor capacidade de ignição e menor consumo de combustível. Devido ao fino eléctrodo central, requerem menos tensão de ignição e protege eficazmente a bobina de ignição. As velas Iridium IX são por isso também a solução perfeita para muitos carros clássicos.



Laser Platinum / Laser Iridium: as velas de ignição Premium

O jóquer de metal precioso da NGK SPARK PLUG oferece um desempenho absoluto com baixo consumo. A tecnologia perfeita para os motores modernos. Estas velas de ignição acompanham o negócio de equipamento original dos mais importantes fabricantes de veículos.



LPG LaserLine: a gama de produtos para GNC / GPL

Oito velas de ignição com duplo metal precioso especialmente desenvolvidas para motores a gás natural e GPL. A escolha perfeita para a maioria dos veículos passíveis de conversão na Europa, com o já consagrado sistema de numeração curta da NGK SPARK PLUG para uma alocação eficiente e para recomendações.



NGK Racing: desempenho sem compromissos

Velas de ignição especiais para motores de altas rotações e condições de operação extremas. Muitos anos dedicados ao desenvolvimento de um campeão mundial e fornecedor oficial de equipas de desportos motorizados mundialmente reconhecidas.

ΥΨΗΛΟΤΕΡΕΣ ΠΡΟΔΙΑΓΡΑΦΕΣ ΠΟΙΟΤΗΤΑΣ ΑΠΟ ΤΟΝ ΚΟΡΥΦΑΙΟ ΚΑΤΑΣΚΕΥΑΣΤΗ ΠΑΓΚΟΣΜΙΩΣ. ΠΡΟΘΕΡΜΑΝΤΗΡΕΣ. Η ΒΑΣΙΚΗ ΓΚΑΜΑ.



Σειρά Yellow Box: πλήρης γκάμα προϊόντων των κορυφαίων κατασκευαστών
Στην ανεξάρτητη δευτερογενή αγορά (IAM), η NGK SPARK PLUG ακολουθεί συχνά στη γραμμή παραγωγής τις προδιαγραφές κατασκευαστών όπως οι BMW, VW, Citroen, Fiat, Ford, Mazda, Mercedes, Audi, Skoda, Renault, Nissan, Kia, Hyundai, Opel και Peugeot. Η πλήρης γκάμα προϊόντων περιλαμβάνει προθερμαντήρες για σχεδόν κάθε πετρελαιοκίνητο όχημα.



D-Power: προϊόντα υψηλής ζήτησης υπό την ίδια στέγη

Η σειρά δημοφιλών προϊόντων D-Power καλύπτει την πλειονότητα του στόλου οχημάτων της Ευρώπης. Η σειρά περιλαμβάνει πολλούς κωδικούς που πληρούν τις απαιτήσεις των δοκιμασμένων τεχνολογιών Πρώτης Τοποθέτησης (OE). Μεταξύ αυτών οι προθερμαντήρες υψηλής θερμοκρασίας με κεραμική επίστρωση (NHTC) και οι προθερμαντήρες προηγμένης και ταχείας πυράκτωσης (AQGS).

ΜΠΟΥΖΙ. Η ΒΑΣΙΚΗ ΓΚΑΜΑ.



Σειρά Yellow Box: απλά πλήρης

Η πλήρης σειρά με πληθώρα επιλογών μπουζί σύμφωνα με τις προδιαγραφές της αγοράς Πρώτης Τοποθέτησης (OE).



V-Line: τα προϊόντα υψηλής ζήτησης

Χάρη στις υψηλές πωλήσεις και τα εξίσου υψηλά περιθώρια κέρδους, η συγκεκριμένη γκάμα προϊόντων, με τους 55 κωδικούς μπουζί που περιλαμβάνει, προσφέρει ευρεία κάλυψη της αγοράς. Η πλειονότητα των κωδικών V-Line πληροί τις προδιαγραφές πρώτης τοποθέτησης (OE) και περιλαμβάνει μεγάλο αριθμό μπουζί κατασκευασμένων με χρήση ευγενών μετάλλων.

ΥΨΗΛΟΤΕΡΗ ΑΠΟΔΟΣΗ. ΥΨΗΛΗ ΤΕΧΝΟΛΟΓΙΑ. ΜΠΟΥΖΙ. ΟΙ ΕΙΔΙΚΕΣ ΛΥΣΕΙΣ.



Iridium IX: συνδυασμένη τεχνολογία

Μπουζί με εξαιρετικά λεπτό κεντρικό ηλεκτρόδιο συγκολλημένο με λέιζερ και ειδική τεχνολογία για την αντιμετώπιση προβλημάτων ανάφλεξης που προκαλούν οι επικαθίσεις αιθάλης. Για εγγυημένα βελτιωμένα αναφλεξιμότητα και χαμηλή κατανάλωση καυσίμου - κάθε φορά. Χάρη στο στενό τους κεντρικό ηλεκτρόδιο απαιτούν μικρότερη τάση ανάφλεξης προστατεύοντας το πηνίο ανάφλεξης. Για αυτό, τα μπουζί Iridium IX είναι η ιδανική λύση για πολλά αυτοκίνητα vintage.



Laser Platinum / Laser Iridium: τα κορυφαία μπουζί

Τα προϊόντα τζόκερ της NGK SPARK PLUG τεχνολογίας ευγενών μετάλλων συνδυάζουν απόλυτη απόδοση με χαμηλή κατανάλωση. Η ιδανική τεχνολογία για σύγχρονους κινητήρες. Τα συγκεκριμένα μπουζί πληρούν τις προδιαγραφές πρώτης τοποθέτησης (OE) των σημαντικότερων κατασκευαστών οχημάτων.



LPG LaserLine: η σειρά προϊόντων για CNG / LPG

Οκτώ διπλά μπουζί κατασκευασμένα με χρήση ευγενών μετάλλων, σχεδιασμένα ειδικά για κινητήρες φυσικού αερίου και LPG. Η ιδανική επιλογή για την πλειονότητα των οχημάτων που κυκλοφορούν στην Ευρώπη, με το δοκιμασμένο σύστημα κωδικοποίησης NGK SPARK PLUG για αποτελεσματική ταξινόμηση και καταχώριση επαναλαμβανόμενων παραγγελιών.



NGK Racing: επιδόσεις χωρίς συμβιβασμούς

Ειδικά μπουζί για κινητήρες υψηλών στροφών και ακραίες συνθήκες λειτουργίας. Πολλά έτη ανάπτυξης ενός παγκόσμιου πρωταθλητή και επίσημος προμηθευτής παγκοσμίως γνωστών ομάδων του μηχανοκίνητου αθλητισμού.

DÜNYA LİDERİNİN SUNDUĞU KALİTE. KIZDIRMA BUJİLERİ. TEMEL ÜRÜN SERİSİ.



Sarı Kutu Serisi: lider üreticilerin ürün yelpazelerinin tamamı

NGK SPARK PLUG Bağımsız Satış Sonrası Ürün ve Hizmetler Pazarında çoğunlukla BMW, VW, Citroen, Fiat, Ford, Mazda, Mercedes, Audi, Skoda, Renault, Nissan, Kia, Hyundai, Opel ve Peugeot gibi markalar için seri üretim gerçekleştirir. Ürün yelpazesinin tamamı, neredeyse tüm dizel araçlara yönelik kızdırma bujileri içerir.



D-Power: aynı çatı altında hızlı hareket eden parçalar

D-Power'ın hızlı hareket eden ürün yelpazesi, Avrupa bölgesindeki otomobil filolarının genel çoğunluğuna hitap eder. Ürün yelpazesinde, orijinal ekipmanların kanıtlanmış teknolojilerine uygun birçok parça bulunmaktadır. NHTC ve AQGS kızdırma bujileri de bunlara dahildir.

ATEŞLEME BUJİLERİ. TEMEL ÜRÜN SERİSİ.



Sarı Kutu Serisi: her şeyiyle tam

Birçok kıvılcımlı bujinin yer aldığı ürün yelpazesinin tamamı, orijinal ekipmanlar ile uyumludur.



V-Line: hızlı hareket eder

Ürün yelpazesi, sahip olduğu yüksek devir hızı ve aynı derecedeki yüksek getirisi sayesinde 55 kıvılcımlı bujiyle pazarın oldukça büyük bir kısmına sahiptir. V-Line tiplerinin birçoğu, orijinal ekipmanlarla uyumludur ve aralarında çok sayıda değerli metale sahip buji yer alır.

DAHA YÜKSEK PERFORMANS. DAHA YÜKSEK TEKNOLOJİ. ATEŞLEME BUJİLERİ. ÖZEL ÇÖZÜMLER.



Iridium IX: birleşik uzmanlık

Kaynak işlemi lazerle yapılmış çok ince bir orta elektroda ve kurumdan kaynaklanan ateşleme sorunlarına karşı özel teknolojiye sahip kıvılcımlı bujiler. Daima daha düşük yakıt tüketimi ve gelişmiş ateşlenebilirlik için. İnce orta elektrodu ile ateşleme için daha az voltaja ihtiyaç duyar ve ateşleme bobini için koruma sağlar. Iridium IX bujileri bu nedenle, birçok klasik araba için de mükemmel bir çözümdür.



Laser Platinum / Laser Iridium: premium kıvılcımlı bujiler

NGK SPARK PLUG kıymetli metal Joker, düşük tüketimle mükemmel performans sunar. Modern motorlar için en ideal teknolojiye sahiptir. Bu kıvılcımlı bujiler, en önemli taşıt üreticilerinin orijinal ekipmanlarıyla uyum içerisindedir.



LPG LaserLine: CGN / LPG ürün yelpazesi

Doğal gaz ve LPG kullanan motorlar için özel olarak geliştirilen sekiz çift değerli metale sahip kıvılcımlı bujiler. Verimli dağıtım ve yeniden sipariş konusunda kanıtlanmış NGK SPARK PLUG kısa numaralandırma sistemi ile Avrupa'daki tüm dönüştürülebilir araçların çoğu için mükemmel seçimidir.



NGK Racing: ödün vermeyen performans

Yüksek devirli motorlar ve ekstrem çalışma koşullarına özel kıvılcımlı bujiler. Dünyanın bir numaralı buji markasının uzun yıllar süren geliştirmeleri ve tüm dünyadaki tanınmış motor sporları takımlarının resmi tedarikçisi.

JAKOŚĆ ŚWIATOWEGO LIDERA. ŚWIECE ŻAROWE. ASORTYMENT PODSTAWOWY.



Yellow Box Line: kompletny asortyment produktów wiodących producentów

Na niezależnym rynku części zamiennych ŚWIECE ZAPŁONOWE NGK są często wybierane przez użytkowników pojazdów wielu marek, takich jak: BMW, VW, Citroen, Fiat, Ford, Mazda, Mercedes, Audi, Skoda, Renault, Nissan, Kia, Hyundai, Opel czy Peugeot. Pełny asortyment produktów obejmuje świece żarowe do praktycznie każdego pojazdu z silnikiem Diesla.



D-Power: asortyment szybkiej rotacji pod jednym dachem

Asortyment szybkiej rotacji D-Power pokrywa większość zapotrzebowania europejskiej floty pojazdów. Ta seria obejmuje wiele produktów, w których zastosowano sprawdzone technologie czołowych producentów motoryzacyjnych. W tej serii dostępne są m.in. świece żarowe NHTC i AQGS.

ŚWIECE ZAPŁONOWE. ASORTYMENT PODSTAWOWY.



Linia Yellow Box: po prostu kompleksowo

Wszelkstronna oferta produktów obejmująca wiele świec zapłonowych spełniających standard oryginalnego wyposażenia.



V-Line: asortyment szybkiej rotacji

Dzięki wysokiemu wskaźnikowi rotacji oraz lojalności klientów, ta seria, obejmująca 55 typów świec zapłonowych, osiąga bardzo duże pokrycie rynku. Większość świec V-Line spełnia standard wyposażenia oryginalnego – wiele typów świec zapłonowych z tej serii wykonanych jest z metali szlachetnych.

WIĘCEJ MOCY. WIĘCEJ NOWOCZESNYCH TECHNOLOGII. ŚWIECE ZAPŁONOWE. ROZWIĄZANIA SPECJALNE.



Iridium IX: wszechstronne doświadczenie

Świece zapłonowe z wyjątkowo cienką, spawaną laserowo elektrodą środkową i specjalną technologią zapobiegającą problemom z zapłonem spowodowanym przez sadzę. Gwarantujemy lepszy zapłon i mniejsze zużycie paliwa w każdych warunkach. Zastosowanie wąskiej elektrody środkowej sprawia, że zapłon wymaga niższego napięcia, co przedłuża trwałość cewki zapłonowej. Właśnie dlatego świece Iridium IX stanowią również doskonałe rozwiązanie dla wielu samochodów zabytkowych.



Laser Platinum / Laser Iridium: świece zapłonowe klasy Premium

ŚWIECE ZAPŁONOWE NGK z metalu szlachetnego zapewniają najlepsze osiągi i niższe zużycie paliwa. Idealna technologia dla nowoczesnych silników. Te świece zapłonowe spełniają standard wyposażenia oryginalnego producentów pojazdów czołowych marek.



LPG LaserLine: asortyment produktów do CNG / LPG

Osiem podwójnych świec zapłonowych z metalu szlachetnego, opracowanych specjalnie do silników zasilanych gazem ziemnym i LPG. Idealne rozwiązanie dla większości pojazdów przystosowanych do konwersji dostępnych na rynku europejskim – ze sprawdzonym systemem krótkiej numeracji NGK, ułatwiającym dopasowanie świec i ponowne zamawianie.



NGK Racing: Wydajność bez kompromisów

Specjalne świece zapłonowe do silników wysokoobrotowych, przystosowane do ekstremalnych warunków pracy. Wieloletnie doświadczenie światowego lidera oraz oficjalnego dostawcy popularnych zespołów.

KVALITA OD SVĚTOVÉHO LÍDRA. ŽHAVICÍ SVÍČKY. ZÁKLADNÍ PRODUKTOVÁ ŘADA.



Yellow Box Line: kompletní produktová řada předních výrobců

Na nezávislém trhu náhradních dílů NGK SPARK PLUG často realizuje sériovou výrobu pro např. BMW, VW, Citroen, Fiat, Ford, Mazda, Mercedes, Audi, Škoda, Renault, Nissan, Kia, Hyundai, Opel a Peugeot. Kompletní produktová řada zahrnuje žhavicí svíčky prakticky pro každé naftové vozidlo.



D-Power: rychloobrátkové zboží pod jednou střechou

Řada rychloobrátkového zboží D-Power pokrývá naprostou většinu evropského vozového parku. Produktová řada zahrnuje mnoho položek navazujících na osvědčené technologie originálního vybavení. Včetně žhavicích svíček NHTC a AQGS.

ZAPALOVACÍ SVÍČKY. ZÁKLADNÍ PRODUKTOVÁ ŘADA.



Yellow Box Line: jednoduše kompletní

Kompletní produktová řada s mnoha zapalovacími svíčkami, která navazuje na segment originálního vybavení.



V-Line: rychloobrátková řada

Produktová řada díky vysoké rychlosti obratu a stejně vysoké návratnosti dosahuje s 55 zapalovacími svíčkami velmi vysoké pokrytí trhu. Většina typů V-Line se odvíjí od originálního vybavení, mezi nimi mnoho zapalovacích svíček z drahých kovů.

LEPŠÍ VÝKON. VÍCE HIGH-TECH. ZAPALOVACÍ SVÍČKY. SPECIÁLNÍ ŘEŠENÍ.



Iridium IX: kombinovaná odbornost

Zapalovací svíčky s extrémně tenkou, laserem svařovanou centrální elektrodou a speciální technologií zamezující problémům se zapalováním způsobeným sazemi. Vždy zajistí lepší zapalování a nižší spotřebu paliva. Díky své úzké centrální elektrodě vyžaduje menší zapalovací napětí a poskytuje ochranu zapalovací cívice. Svíčky Iridium IX jsou proto také dokonalým řešením pro mnoho veteránů.



Laser Platinum / Laser Iridium: prémiové zapalovací svíčky

Žolík NGK SPARK PLUG z ušlechtilého kovu nabízí absolutní výkon s nízkou spotřebou. Ideální technologie pro moderní motory. Tyto zapalovací svíčky se řídí segmentem originálního vybavení u nejvýznamnějších výrobců vozidel.



LPG LaserLine: produktová řada pro CNG / LPG

Osm dvojitých zapalovacích svíček ze vzácných kovů speciálně vyvinutých pro motory na zemní plyn a LPG. Ideální volba pro většinu vozidel v Evropě umožňujících přestavbu s osvědčeným systémem krátkého číslování NGK SPARK PLUG pro efektivní alokaci a opětovné objednání.



NGK Racing: výkon bez kompromisů

Speciální zapalovací svíčky pro motory s vysokými otáčkami a extrémní provozní podmínky. Mnoho let vývoje světové jedničky a oficiálního dodavatele celosvětově známých týmů motoristického sportu.

EGY VILÁGELSŐ ÁLTAL BIZTOSÍTOTT MINŐSÉG. IZZÍTÓGYERTYÁK. AZ ALAP TERMÉKSKÁLA.



Sárga dobozos termékcsalád: vezető gyártók teljes termékválasztéka

A független szervizpiacon az NGK SPARK PLUG gyakran a sorozatgyártást követi pl. BMW, VW, Citroen, Fiat, Ford, Mazda, Mercedes, Audi, Skoda, Renault, Nissan, Kia, Hyundai, Opel és Peugeot típusokhoz. A teljes termékválaszték gyakorlatilag az összes dízeljárműhöz való izzítógyertyákat tartalmazza.



D-Power: gyorsan forgó termékek egy márkánév alatt

A D-Power gyorsan forgó termékválaszték az európai autóflotta túlnyomó többségét lefedi. A termékválaszték az eredeti gyártó (OE) bevált technológiáin alapuló számos terméket tartalmaz. Ide tartoznak az NHTC és az AQGS izzítógyertyák.

GYÚJTÓGYERTYÁK. AZ ALAP TERMÉKSKÁLA.



Sárga dobozos termékcsalád: egyszerűen teljes körű

A teljes termékválaszték az eredeti gyártó (OE) technológiáin alapuló számos gyújtógyertyával.



V-Line: a gyorsan forgó

A termékválaszték – a nagy forgási sebességnek és az ennek megfelelő magas megtérülésnek köszönhetően – 55 gyújtógyertyával jelentős piaci lefedettséget ér el. A V-Line típusok – köztük számos nemesfém gyújtógyertya – többsége ez eredeti berendezéseknek felel meg.

NAGYOBB TELJESÍTMÉNY. TÖBB CSÚCSTECHNOLÓGIA. GYÚJTÓGYERTYÁK. SPECIÁLIS MEGOLDÁSOK.



Iridium IX: egyesített szakértelem

Rendkívül vékony, lézerhegesztett központi elektródával és a korom okozta gyújtást megakadályozó speciális technológiával ellátott gyújtógyertyák. A jobb gyújtóképesség és az alacsonyabb üzemanyag-fogyasztás állandó biztosítása érdekében. A keskeny központi elektróda miatt kisebb gyújtófeszültséget igényel, valamint védelmet nyújt a gyújtótékercsnek. Az Iridium IX gyertyák ezért tökéletes megoldást jelentenek számos régi autó számára is.



Laser Platinum / Laser Iridium: a prémium gyújtógyertyák

Az NGK SPARK PLUG joker nemesfémje alacsony fogyasztás mellett is tökéletes teljesítményt nyújt. Az ideális technológia modern motorokhoz. Ezek a gyújtógyertyák a legfontosabb járműgyártók eredeti gyártói (OE) technológiáin alapulnak.



LPG LaserLine: termékválaszték a CNG / LPG üzemanyagokhoz

Kifejezetten földgázzal és LPG-vel hajtott motorokhoz kifejlesztett nyolc, dupla nemesfém gyújtógyertya. Tökéletes választás Európában az átállítható járművek többségéhez, a bevált NGK SPARK PLUG rövid számozási rendszerével a hatékony hozzárendeléshez és utánrendeléshez.



NGK Racing: teljesítmény kompromisszumok nélkül

Speciális gyújtógyertyák nagy fordulatszámú motorokhoz és szélsőséges üzemi körülményekhez. Egy világbajnok és a világszerte jól ismert motorsport-csapatok hivatalos szállítójának sok éves fejlesztése.

КАЧЕСТВО ОТ ЛИДЕРА РЫНКА. СВЕЧИ НАКАЛИВАНИЯ. ВАШ БАЗОВЫЙ АССОРТИМЕНТ.



Yellow Box Line: полный ассортимент от ведущих производителей

На независимом рынке послепродажного обслуживания NGK SPARK PLUG часто идет в ногу с серийным производством, например, для BMW, VW, Citroen, Fiat, Ford, Mazda, Mercedes, Audi, Skoda, Renault, Nissan, Kia, Hyundai, Opel и Peugeot. Полный ассортимент продукции включает в себя свечи накаливания, которые подойдут практически любому автомобилю с дизельным двигателем.



D-Power: скоростная продукция из единого источника

Ассортимент скоростной продукции D-Power покрывает большую часть европейского автопарка. Здесь вы найдете множество позиций, соответствующих проверенным оригинальным технологиям. В том числе — свечи накаливания NHTC и AQGS.

СВЕЧИ ЗАЖИГАНИЯ. ВАШ БАЗОВЫЙ АССОРТИМЕНТ.



Yellow Box Line: всё, что нужно

Полный ассортимент продукции со множеством свечей зажигания, повторяющий ассортимент оригинального оборудования.



V-Line: на высокой скорости

Ассортимент продукции с высокой оборачиваемостью и столь же высокой доходностью включает в себя 55 свечей зажигания и покрывает большую часть рынка. Большинство типов V-Line соответствуют оригинальному оборудованию, в том числе — свечам зажигания из драгоценных металлов.

БОЛЬШЕ МОЩНОСТИ. БОЛЬШЕ ВЫСОКИХ ТЕХНОЛОГИЙ. СВЕЧИ ЗАЖИГАНИЯ. СПЕЦИАЛЬНЫЕ РЕШЕНИЯ.



Iridium IX: объединенный опыт

Свечи зажигания со сверхтонким центральным электродом с лазерной сваркой и специальной технологией, предотвращающей проблемы с зажиганием, вызванные образованием сажи. Это обеспечивает улучшенное зажигание и снижение расхода топлива при каждой поездке. Узкий центральный электрод требует меньшего напряжения при зажигании и защищает катушку зажигания. Поэтому свечи Iridium IX также станут идеальным решением для многих винтажных автомобилей.



Laser Platinum / Laser Iridium: свечи зажигания премиум-класса

Эти продукты NGK SPARK PLUG из драгоценного металла невероятно производительны и предельно экономичны. Идеальная технология для современных двигателей. Эти свечи зажигания повторяют производство оригинальных комплектующих основных автопроизводителей.



LPG LaserLine: ассортимент продукции для СУГ / СПГ

Восемь двойных свечей зажигания из благородных металлов, специально разработанные для двигателей, работающих на природном газе и СУГ. Идеальный выбор для большинства европейских автомобилей с возможностью переоборудования, с проверенной системой короткой нумерации NGK SPARK PLUG для эффективного распределения и повторного заказа.



NGK Racing: производительность без компромиссов

Специальные свечи зажигания для высокооборотных двигателей и экстремальных условий эксплуатации. Многолетний опыт разработки от мирового чемпиона и официального поставщика всемирно известных гоночных команд.

D-Power Range

D-POWER ^{NGK}

D-Power	Type	Car Manufacturer
1	Y-924J	ALFA ROMEO, BMW, CHRYSLER, CITROEN, DAF, FIAT, FORD, FSO, HONDA, HYUNDAI, INNOCENTI, JEEP, LADA (AVTOVAZ), LANCIA, LAND ROVER, MERCEDES, OPEL, PEUGEOT, RENAULT, ROVER, SEAT, SUZUKI
2	Y-918J	AUDI, MERCEDES, SEAT, SKODA, VOLVO, VW
3	Y-910J	CITROEN, FIAT, FORD, LADA (AVTOVAZ), LANCIA, MAZDA, OPEL, PEUGEOT, RENAULT, ROVER
4	Y-732J	AUDI, DACIA, FORD, MITSUBISHI, NISSAN, OPEL, RENAULT, SEAT, SKODA, SUZUKI, VOLVO, VW
5	Y-937J	FORD
6	Y-916J	DAEWOO, MERCEDES, SSANGYONG, STEYR
7	Y-506J	OPEL, RENAULT
10	Y-503J	CITROEN, FIAT, LADA (AVTOVAZ), NISSAN, PEUGEOT, RENAULT, ROVER
11	Y-745U	CHRYSLER, MERCEDES
12	Y-516J	DACIA, RENAULT
13	Y-733J	MITSUBISHI
14	Y-748U	OPEL, SAAB
15	Y-913J	JEEP, RENAULT
16	Y-925J	MERCEDES
17	Y-730U	HONDA, LAND ROVER, MG, RENAULT, ROVER
19	Y-927J	RENAULT
20	Y-741U	ALFA ROMEO, AUDI, CHRYSLER, FORD, JEEP, OPEL, PORSCHE, ROVER, SEAT, SKODA, VW
22	Y-740U	RENAULT, VOLVO
24	Y-504J	CITROEN, FIAT, LANCIA, PEUGEOT, SUZUKI
25	Y-933J	MITSUBISHI, RENAULT, VOLVO
26	Y-747U	ALFA ROMEO, FIAT, LANCIA
27	Y-524J	FORD
28	Y-711J	ISUZU, OPEL
29	Y-928U	FIAT, LANCIA
30	Y-930U	MERCEDES
31	Y-501U	AUDI, SKODA, VW
32	Y-507J	BMW, LAND ROVER, MG, ROVER
34	Y-729U	LAND ROVER
36	Y-534J	ALFA ROMEO, FIAT, LANCIA, OPEL, SAAB
37	Y-523J	OPEL, SAAB
38	Y-746J	MERCEDES
39	Y-701J	KIA, MAZDA, SUZUKI
40	YE04	CITROEN, FORD, MAZDA, PEUGEOT, SUZUKI, VOLVO
41	Y-929U	MERCEDES
42	Y-541J	HONDA, OPEL
43	Y-939J	FIAT
44	Y-531J	TOYOTA

D-Power	Type	Car Manufacturer
45	Y-542J	MINI, TOYOTA
46	Y-543J	SMART
47	Y-547AS	ALPINA, BMW
48	YE14	AUDI, MITSUBISHI, SEAT, SKODA, VW
49	Y-609AS	AUDI, SEAT, VW
50	Y-607AS	AUDI, CHRYSLER, SEAT, SKODA, VW
51	Y8002AS	CHRYSLER, JEEP, MERCEDES
52	CZ104	AUDI, SEAT, SKODA, VW
53	CZ106	MERCEDES
54	CZ303	MERCEDES
55	CZ304	AUDI, JEEP, MITSUBISHI, SEAT, SKODA, VW
56	Y1005J	CITROEN, FIAT, FORD, PEUGEOT, VOLVO
57	Y1002AS	AUDI, PORSCHE, SEAT, SKODA, VW
58	Y8001AS	CITROEN, FORD, PEUGEOT
59	Y1007J	MITSUBISHI
60	Y-603J	MAZDA, OPEL
61	Y-519J	NISSAN
62	Y8003J	ALFA ROMEO, FIAT, FORD, LANCIA, OPEL, SUZUKI
63	Y1013J	TOYOTA
64	Y8005J	CITROEN, FIAT, PEUGEOT
65	Y1012J	TOYOTA
66	Y-517J	NISSAN, OPEL, RENAULT
67	Y-527J	HYUNDAI, KIA
68	CZ203	HYUNDAI, KIA
69	Y-526J1	MAZDA
70	Y1030J	ALFA ROMEO, FIAT, OPEL, SUZUKI
71	Y1031J	CHRYSLER, JEEP
72	Y9001AS	ALFA ROMEO, CITROEN, FIAT, LANCIA, PEUGEOT
73	YE05	CITROEN, FORD, MINI, PEUGEOT, TOYOTA, VOLVO
74	Y8008AS	VOLVO
75	Y-548J	CITROEN, FIAT, FORD, JAGUAR, PEUGEOT
76	CZ251	MITSUBISHI
77	Y1035AS	DACIA, MERCEDES, NISSAN, RENAULT
78	Y9003AS	ALFA ROMEO, FIAT, LANCIA, SAAB, SUZUKI
80	Y1039AS	MINI
81	Y-536J	SSANGYONG
82	CZ163	MAZDA
83	CZ257	HYUNDAI, KIA, MITSUBISHI
84	CZ159	MERCEDES
85	CZ551	MERCEDES
87	CZ165	MAZDA
88	Y1010AS	MERCEDES, OPEL, RENAULT
89	Y1045AS	FORD
90	CZ267	MITSUBISHI
91	CZ167	NISSAN, OPEL, RENAULT



D-Power Cross List

D-Power	NGK	BERU	BOSCH
1	Y-924J	603 MJ 609 MJ 613 MJ 624 MJ 633 MJ 636 MJ 642 MJ 663 MJ 719 MJ 908 MJ 909 MJ 917 MJ 954 MJ GN 013 GN 908 GN 909 GN 917 GN 954 GV 603 GV 636 GV 642 GV 663 GV 719	GLP 001 GLP 005 GLP 015
2	Y-918J	601 MJ 857 MJ GN 857	GLP 002
3	Y-910J	661 MJ 666 MJ 927 MJ GN 927 GV 661 GV 666	GLP 010 GLP 121
4	Y-732J	855 MJ 950 MJ GN 018 GN 855	GLP 003 GLP 224
5	Y-937J	GN 022	GLP 012
6	Y-916J	858 MJ GN 858	GLP 006
7	Y-506J	963 MJ GN 963	GLP 009
10	Y-503J	912 MJ GN 016 GN 912	GLP 004
11	Y-745U	GN 003	GLP 008 GLP 022
12	Y-516J	GN 019	GLP 011
13	Y-733J	GN 107	GLP 054
14	Y-748U	GN 992	GLP 019
15	Y-913J	852 MJ GV 852	GLP 037
16	Y-925J	948 MJ GN 948	GLP 017
17	Y-730U	905 MJ GN 905	GLP 014
19	Y-927J	991 MJ GN 991	GLP 020
20	Y-741U	GN 007 GN 046	GLP 023 GLP 033

D-Power	NGK	BERU	BOSCH
22	Y-740U	999 MJ GN 999	-
24	Y-504J	GN 027	GLP 013
25	Y-933J	844 MJ 959 MJ GN 959 GV 844	GLP 036
26	Y-747U	GN 017	GLP 032
27	Y-524J	GN 993	GLP 024
28	Y-711J	947 MJ GV 947	GLP 046
29	Y-928U	970 MJ GN 970	GLP 026
30	Y-930U	860 MJ GN 860	GLP 025
31	Y-501U	GN 008	GLP 031
32	Y-507J	GN 024	GLP 040
34	Y-729U	783 MJ GV 783	GLP 048
36	Y-534J	GN 041	GLP 007
37	Y-523J	GN 033	GLP 030
38	Y-746J	GN 010	GLP 102
39	Y-701J	GN 005	GLP 038
40	YE04	GN 047	GLP 059
41	Y-929U	961 MJ GN 961	GLP 021
42	Y-541J	GN 104	GLP 092
43	Y-939J	GN 030	GLP 045
44	Y-531J	GN 065	GLP 101
45	Y-542J	GN 042	-
46	Y-543J	GN 015	-
47	Y-547AS	GE 102	GLP 070
48	YE14	GE 101	GLP 093
49	Y-609AS	GE 108 GE 115	-
50	Y-607AS	GE 100	GLP 050
51	Y8002AS	GE 105	GLP 202
52	CZ104	CGP 002	-
53	CZ106	-	-
54	CZ303	-	-
55	CZ304	-	-
56	Y1005J	GN 054	GLP 055 GLP 111
57	Y1002AS	-	GLP 194
58	Y8001AS	GE 121 GE 121 A	-
59	Y1007J	-	GLP 137
60	Y-603J	GN 103	GLP 035
61	Y-519J	GN 109	-
62	Y8003J	GN 053	GLP 016

D-Power	NGK	BERU	BOSCH
63	Y1013J	GN 110	-
64	Y8005J	GN 037	GLP 205
65	Y1012J	GN 108	GLP 212
66	Y-517J	GN 026	GLP 057
67	Y-527J	GN 062	-
68	CZ203	-	-
69	Y-526J1	-	-
70	Y1030J	GN 097	GLP 066
71	Y1031J	GN 055	GLP 109
72	Y9001AS	GE112	GLP226
73	YE05	GN 056	GLP 094
74	Y8008AS	-	GLP 144
75	Y-548J	GN 939	GLP 051
76	CZ251	-	GLP252
77	Y1035AS	GE 110	GLP 221
78	Y9003AS	GE 114	GLP 196
80	Y1039AS	GE 118	-
81	Y-536J	GN 060	-
82	CZ163	-	-
83	CZ257	-	GLP 039
84	CZ159	-	-
85	CZ551	-	-
87	CZ165	-	-
88	Y1010AS	GE 124	GLP 237
89	Y1045AS	GE 122	GLP 233
90	CZ267	GN 123	GLP 251
91	CZ167	CGP 007	GLP 154



V-Line Range



V-Line	Type	Car Manufacturer
1	BUR6ET	AUDI, FIAT, LANCIA, SEAT, SKODA, VW
2	BPR6E	ALFA ROMEO, ALPINA, AUSTIN, AUTOBIANCHI, AZLK (MOSKWITCZ), CHEVROLET, CHRYSLER, DAEWOO, DAIHATSU, FIAT, FORD, INNOCENTI, ISUZU, KIA, LADA (AVTOVAZ), LANCIA, LAND ROVER, LOTUS, MAZDA, MG, MITSUBISHI, MORGAN, NISSAN, OPEL, PORSCHE, PROTON, RENAULT, ROVER, SEAT, SUBARU, SUZUKI, TOFAS, TVR, VOLVO
3	BPR6H	DACIA, OPEL
4	BP6E	ALFA ROMEO, AUSTIN, AZLK (MOSKWITCZ), CITROEN, FIAT, INNOCENTI, LADA (AVTOVAZ), LAND ROVER, MERCEDES, MITSUBISHI, MORGAN, NISSAN, RENAULT, SAAB, TOFAS, TRABANT, WARTBURG AWE
5	BP6EF	MERCEDES, RENAULT
6	BPR5E	ASIA MOTORS, AZLK (MOSKWITCZ), CHEVROLET, DACIA, DAEWOO, FIAT, GAZ (VOLGA), HYUNDAI, INNOCENTI, LADA (AVTOVAZ), LAND ROVER, MAZDA, MITSUBISHI, NISSAN, OPEL, PROTON, RENAULT, SEAT, SUZUKI, TOYOTA, TVR,
7	BPR6EF	FORD, LANCIA, TVR, VOLVO
8	BP5E	BMW, LADA (AVTOVAZ), MITSUBISHI, NISSAN, RENAULT
9	BPR5EY	DAIHATSU, INNOCENTI, SUZUKI, TOYOTA
10	BPR6EY-11	HONDA, TOYOTA
11	BCPR6E-11	ACURA, FORD, HONDA, LADA (AVTOVAZ), MAZDA, MITSUBISHI, NISSAN, ROVER, SAAB, SUBARU
12	BCPR6E	ASTON MARTIN, AUTOBIANCHI, CHRYSLER, CITROEN, DAIMLER, FIAT, FORD, JAGUAR, LANCIA, MAZDA, MORGAN, NISSAN, PEUGEOT, RENAULT, ROVER, SKODA, TVR, VOLVO
13	BPR6ES-11	CHEVROLET, HYUNDAI, ISUZU, KIA, LADA (AVTOVAZ), MAZDA, MITSUBISHI, NISSAN, SUBARU, SUZUKI
14	BKR6E-11	CHEVROLET, DAEWOO, DAIHATSU, HONDA, ISUZU, KIA, LOTUS, MAZDA, MITSUBISHI, NISSAN, NISSAN, PEUGEOT, PROTON, RENAULT, ROVER, SUBARU, SUZUKI
15	ZGR5A	BERTONE, BMW
16	BCP5E	CITROEN, DAEWOO, MERCEDES, NISSAN, PEUGEOT, RENAULT, SSANGYONG
17	BCP6E	ALFA ROMEO, CITROEN, LADA (AVTOVAZ), MERCEDES, NISSAN, PEUGEOT, RENAULT, ROVER
18	BP6H	ABARTH, CITROEN, DACIA, DAF, FORD, GAZ (VOLGA), MERCEDES, OPEL, RENAULT, SKODA, VOLVO
19	BPR7E	ALFA ROMEO, AUSTIN, FIAT, FORD, LANCIA, LOTUS, MITSUBISHI, PORSCHE, SUBARU, VOLVO
20	BKR6EK	ALPINA, BENTLEY, BERTONE, BMW, CITROEN, DACIA, DAEWOO, FIAT, HOMMEL, LADA (AVTOVAZ), LANCIA, MERCEDES, OPEL, PEUGEOT, PORSCHE, RENAULT, ROLLS ROYCE, SAAB, WIESMANN

V-Line	Type	Car Manufacturer
21	BUR5ET-10	SEAT, VW
22	BUR5ET	AUDI, SEAT, VW
23	BKR5EK	CADILLAC, CHEVROLET, CITROEN, DAEWOO, FIAT, LANCIA, NISSAN, OPEL, PEUGEOT, RENAULT, SAAB, TOFAS / FIAT
24	BKUR6ET-10	AUDI, MERCEDES, SEAT, SKODA, VW
25	PTR5A-13	CHEVROLET, CHRYSLER, FORD, HUMMER-AM GENERAL, MAZDA, MORGAN, OPEL
26	BKR6EKC	DAIHATSU, FIAT, FIAT, LANCIA, LOTUS, RENAULT, TOFAS / FIAT
27	BKUR6ET	FIAT, LANCIA, SEAT
28	BKR6E	AUDI, CHRYSLER, CITROEN, DACIA, DODGE, FIAT, FSO, HYUNDAI, KIA, LADA (AVTOVAZ), LANCIA, LAND ROVER, LOTUS, NISSAN, OPEL, PEUGEOT, PORSCHE, RENAULT, ROVER, SEAT, SKODA, SUBARU, SUZUKI, VOLVO, VW
29	BKUR5ET	MERCEDES, SEAT, VW
30	BKR6EQUP	ALPINA, BENTLEY, BMW, LAND ROVER, MINI, MORGAN, PORSCHE, ROLLS ROYCE
31	PTR5D-10	ASTON MARTIN, FORD, MAZDA
32	BCPR5E	CITROEN, PEUGEOT, RELIANT, RENAULT, SKODA
33	BKR5E-11	CHEVROLET, CHRYSLER, DAEWOO, DAIHATSU, FORD (USA), HYUNDAI, INFINITI, KIA, MAZDA, MITSUBISHI, NISSAN, SUBARU
34	PZFR5D-11	FORD, SEAT, SKODA, VW
35	BKR5E	GAZ (VOLGA), KIA, MAZDA, NISSAN, VW
36	BKR5EZ	CITROEN, FIAT, LANCIA, PEUGEOT, RENAULT, TOFAS / FIAT
37	PFR6Q	AUDI, BENTLEY, SEAT, SKODA, VW
38	BKR6EZ	CITROEN, DACIA, FIAT, LANCIA, NISSAN, PEUGEOT, RENAULT, TOFAS / FIAT
39	BKR5EYA-11	TOYOTA
40	ZFR5F-11	ALFA ROMEO, DODGE, FIAT, HONDA, HYUNDAI, JEEP, KIA, MAZDA, OPEL
41	ZRF5P-G	SEAT, SKODA, VW
42	ZKR7A-10	ALFA ROMEO, FIAT, FORD, LANCIA
43	DCPR7E-N-10	ALFA ROMEO, FIAT, LANCIA
44	ZFR6T-11G	SEAT, SKODA, VW
45	TR5B-13	FORD, VOLVO
46	LFR5B	CITROEN, FIAT, LANCIA, PEUGEOT
47	LFR6B	CITROEN, PEUGEOT
48	LFR6C-11	CITROEN, MITSUBISHI, PEUGEOT, SMART, TOYOTA
49	LZKR6B-10E	HYUNDAI, KIA
50	PFR7S8EG	AUDI, SEAT, SKODA, VW
51	PLZKAR6A-11	NISSAN, RENAULT
52	PZFR6R	AUDI, SEAT, SKODA, VW
53	ZFR5F	BMW, OPEL
54	LZKAR7A	CITROEN, NISSAN, PEUGEOT, RENAULT
55	PZKER7B8EGS	AUDI, SEAT, SKODA, VW



V-Line Cross List



V-line	NGK	BERU	BOSCH	BOSCH +
1	BUR6ET	14GH-7DTUR	WR7LTC+	+2
2	BPR6E	14R-6DU 14R-7DU	WR6DC+ WR7DC+	+12 +1
3	BPR6H	14R-6BU 14R-7BU	WR6BC WR7BC+	+10
4	BP6E	14-6DU 14-7DU	W6DC W7DC	-
5	BP6EF	14K-6DU 14K-7DU	H6DC H7DC	-
6	BPR5E	14R-8DU 14R-9DU	WR8DC+ WR9DC+	+3 +16
7	BPR6EF	14KR-6DU 14KR-7DU	HR6DC+ HR7DC+	+18 +5
8	BP5E	14-8DU 14-9DU	W8DC W9DC	-
9	BPR5EY	-	-	-
10	BPR6EY-11	-	-	-
11	BCPR6E-11	-	-	-
12	BCPR6E	-	-	-
13	BPR6ES-11	14R-6DUX 14R-7DUX	WR6DCX WR7DCX+	+21
14	BKR6E-11	14FR-6DUX 14R-7DUX	FR6DCX FR7DCX+	+11
15	ZGR5A	14-8LUR	WR8LC+ WR9LC	+34
16	BCP5E	14F8DU	F8DC	-
17	BCP6E	14F-7DU	F6DC F7DC	-
18	BP6H	14-6BU 14-7BU	W6BC W7BC	-
19	BPR7E	14R-5DU	WR5DC+	+15
20	BKR6EK	14FR-6LDU 14FR-7LDU	FR6LDC FR7LDC+	+7
21	BUR5ET-10	14GH-8DTURX	WR8LTC+	+4
22	BUR5ET	14GH-8DTUR	W8LTCR 0.8	-
23	BKR5EK	14FR-8LDUOX4	FLR8LDCU+	+9
24	BKUR6ET-10	14FGH7DTURX	F7LTCR	-
25	PTR5A-13	14KR-8MPX 14KR-8MUV	HR7MPP302 HR8MVCV+	+3
26	BKR6EKC	14FR-6LDUW	-	-
27	BKUR6ET	14FGH-6DTUR	FR6KTC	-
28	BKR6E	14FR-6DU 14FR-7DU	FR6DC+ FR7DC+	+13 +8

V-line	NGK	BERU	BOSCH	BOSCH +
29	BKUR5ET	14FGH-8DTURW	F8KTCR	-
30	BKR6EQUP	14FR-7DQUP7	FGR7DQP+	+48
31	PTR5D-10	-	HR8DPP22U	-
32	BCPR5E	-	-	-
33	BKR5E-11	14FR-8DUX	FR8DCX+	+19
34	PZFR5D-11	14F-7HPURX2	FR7HPP33+	+52
35	BKR5E	14FR-8DU	FR8DC+ FR9DC	+6
36	BKR5EZ	-	-	-
37	PFR6Q	14F-7DPUR02	FR7KPP33+	+50
38	BKR6EZ	-	FR7DE FR6KDC+ FR7KDC	+53
39	BKR5EYA-11	14FR8KU0U	FR8KCU	-
40	ZFR5F-11	-	-	-
41	ZFR5P-G	14F-7HUR2	F7HER2 FR7HE2	-
42	ZKR7A-10	-	YR7DC+	+41
43	DCPR7E-N-10	-	YR7DE	-
44	ZFR6T-11G	-	F7HER02 FR7HC+	+51
45	TR5B-13	-	HR8MVCV+ HR8MEV	+39
46	LFR5B	-	FR 8 ME	-
47	LFR6B	14 FR-7 MU2	FR 8 SC+	+42
48	LFR6C-11	-	-	-
49	LZKR6B-10E	-	-	-
50	PFR7S8EG	-	F5 KPP 332SB FR 5 KPP 332 S	-
51	PLZKAR6A-11	-	-	-
52	PZFR6R	-	FR 6 HI 332	-
53	ZFR5F	14 F-8LUR 14 FR-8LU2	F8LCR F8LCR2 FQR 8 LEU2	-
54	LZKAR7A	-	VR8SE VR8SEW	-
55	PZKER7B8EGS	12F-6 LPPR2L	Y5 KPP 332 Y5 KPP 332S	-



LPG No. 1	BKR5E	BKR6EIX-11	BKUR5ET	IFR5J11	PFR4G-11	PFR6G	PFR7B	
	BKR5E-11	BKR6EK	BKUR5ET-10	IFR5N10	PFR5B-9	PFR6G-11	PFR7B-11	
	BKR5EIX	BKR6EKC	BKUR6ET	IFR6B	PFR5C-11	PFR6G-9	PFR7B-9	
	BKR5EIX-11	BKR6EKUB	BKUR6ET-10	IFR6B11	PFR5G-11	PFR6J	PFR7G	
	BKR5EK	BKR6EQUA	FR5AP-10	IFR6B-K	PFR5G-11E	PFR6J-11	PFR7G-11	
	BKR5ES	BKR6EQUP	FR5AP-11	IFR6C	PFR5J-11	PFR6M	PFR7G-11S	
	BKR5ES-11	BKR6ES	FR5CP	IFR6D10	PFR5N-11	PFR6N-11	PFR7G-9	
	BKR5EY	BKR6ES-11	FR5EI	IFR6E11	PFR5P-11	PFR6Q	PFR7M	
	BKR5EY-11	BKR6EY	FR6EI	IFR6G-11K	PFR5R-11	PFR6T-10G	PFR7N-D	
	BKR5EZ	BKR6EYA	IFR5D10	IFR6J11	PFR6B-11	PFR6T-G	PFR7Q	
	BKR6E	BKR6EYA-11	IFR5E11	IFR6S	PFR6B-9	PFR6U-11G	PFR7S8EG	
	BKR6E-11	BKR6EZ	IFR5G11	IFR7G-11KS	PFR6D10G	PFR6X-11	PFR8S8EG	
	BKR6EIX	BKR7EIX	IFR5G-11K	IFR7X8G	PFR6E-10	PFR7AB		

LPG No. 2	BP5E	BP6E	BPR5EIX	BPR5EY-11	BPR6ES-11	BUR5ET		
	BP5ES	BP6ES	BPR5ES	BPR6E	BPR6EY	BUR6ET		
	BP5ESZ	BP6ET	BPR5ES-11	BPR6EIX	BPR6EY-11	PGR5A		
	BP5EY	BPR5E	BPR5EY	BPR6ES	BPR7EIX	PGR6A		

LPG No. 3	BCP5E	BCP6ES-11	BCPR5ES	BCPR6E-11	BCPR6ES	BCPR7EIX	PFR5K-11	PFR6H-10
	BCP5ES	BCPR5EIX	BCPR5ES-11	BCPR6EIX	BCPR6ES-11	BCPR7EIX-11	PFR6A-11	PFR7A-11
	BCP6E	BCPR5EIX-11	BCPR5EY	BCPR6EIX-11	BCPR6EY	PFR5A-11	PFR6A-11A	PFR7H-10
	BCP6ES	BCPR5EIX-11P	BCPR6E	BCPR6EIX-11P	BCPR6EY-11	PFR5F-11A	PFR6F-11A	

LPG No. 4	ILTR5D	LTR6IX-11						
	ILTR6A-8G	PTR5A-10						
	ILTR6G8G	PTR5A-13						
	ILTR6H8G	TR5A-10						

LPG No. 5	BP6EFS	PTR5F-11	TR55					
	BPR6EF	PTR6D-13	TR5IX					
	BPR6EFIX-10	PTR6F-13						
	BPR6EFS	TR5						

LPG No. 6	IZFR5B	IZFR6F11	PZFR5F	PZFR6J-11	ZFR5FIX-11	ZFR5P-G	ZFR6FIX-11	ZFR7F-11
	IZFR5G	IZFR6H11	PZFR5F-11	ZFR4F-11	ZFR5FIX-11P	ZFR6BP-G	ZFR6FIX-11P	ZFR7J-11
	IZFR6B	PZFR5B	PZFR6F	ZFR5F	ZFR5FVX-11	ZFR6F-11	ZFR6J-11	
		PZFR5D-11	PZFR6F-11	ZFR5F-11	ZFR5J-11	ZFR6F-11G	ZFR7F	

LPG No. 7	DILFR6J11	ILFR6B	ILFR6K8	LFR5AIX-11P	LFR6AIX-11	LFR7AIX	PLFR6A	SILFR6A
	DILFR7B10G	ILFR6G	LFR4AP-11	LFR5AP-11	LFR6AIX-11P	LFR7AIX-P	PLFR6A-11	SILFR6A11
	ILFR5B11	ILFR6G-E	LFR5A-11	LFR5B	LFR6AIX-P	PLFER7A8EG	PLFR6A-9	
	ILFR6A	ILFR6J-11K	LFR5AIX-11	LFR5BP-11	LFR6B	PLFR5A-11	PLFR6C-10G	

LPG No. 8	DCPR7E	ZKR7A-10						
	DCPR8E							
	DCPR8EKC							
	DCPR8E-N							



Iridium IX Range



Standard	Iridium	Order No.
AP5FS	WR5IX	7510
APR5FS	WR5IX	7510
B10ES	BR10EIX	6801
B6HS	BR6HIX	3419
B7ES	BR7EIX	6664
B7HS	BR7HIX	7067
B8ES	BR8EIX	5044
B8HS	BR8HIX	7001
B9ES	BR9EIX	3981
B9HS	BR9HIX	5687
BCP5ES	BCPR5EIX	5688
BCP5ES-11	BCPR5EIX-11	3306
BCP6ES	BCPR6EIX	5689
BCP6ES-11	BCPR6EIX-11	4919
BCPR5E-11	BCPR5EIX-11	3306
BCPR5ES	BCPR5EIX	5688
BCPR5ES-11	BCPR5EIX-11	3306
BCPR5EY	BCPR5EIX	5688
BCPR5EY-11	BCPR5EIX-11	3306
BCPR6E-11	BCPR6EIX-11	4919
BCPR6ES	BCPR6EIX	5689
BCPR6ES-11	BCPR6EIX-11	4919
BCPR6EY	BCPR6EIX	5689
BCPR6EY-11	BCPR6EIX-11	4919
BCPR6EY-N-11	BCPR6EIX-11	4919
BK5E	BKR5EIX	6341
BK5E-11	BKR5EIX-11	5464
BK6E	BKR6EIX	6418
BK6E-11	BKR6EIX-11	3764
BKR5E	BKR5EIX	6341
BKR5E-11	BKR5EIX-11	5464
BKR5E-N-11	BKR5EIX-11	5464
BKR5ES	BKR5EIX	6341
BKR5ES-11	BKR5EIX-11	5464
BKR5EY	BKR5EIX	6341
BKR5EY-11	BKR5EIX-11	5464
BKR5EYA	BKR5EIX	6341
BKR5EYA-11	BKR5EIX-11	5464
BKR5EZ	BKR5EIX	6341
BKR6E	BKR6EIX	6418
BKR6E-11	BKR6EIX-11	3764
BKR6E-N	BKR6EIX	6418
BKR6E-N-11	BKR6EIX-11	3764
BKR6ES	BKR6EIX	6418
BKR6ES-11	BKR6EIX-11	3764
BKR6EY	BKR6EIX	6418
BKR6EY-11	BKR6EIX-11	3764

Standard	Iridium	Order No.
BKR6EYA	BKR6EIX	6418
BKR6EYA-11	BKR6EIX-11	3764
BKR6EZ	BKR6EIX	6418
BKR7E	BKR7EIX	2667
BKR7E-N-11	BKR7EIX-11	6988
BKR7ES-11	BKR7EIX-11	6988
BP4FS	UR4IX	7401
BP5ES	BPR5EIX	6597
BP5ES-11	BPR5EIX-11	2115
BP5ESZ	BPR5EIX	6597
BP5EY	BPR5EIX	6597
BP5EY-11	BPR5EIX-11	2115
BP5FS	UR5IX	7177
BP6E	BPR6EIX	6637
BP6ES	BPR6EIX	6637
BP6ES-11	BPR6EIX-11	3903
BP6ESZ	BPR6EIX	6637
BP6EY	BPR6EIX	6637
BP6EY-11	BPR6EIX-11	3903
BP6HS	BPR6HIX	4085
BP6HSA	BPR6HIX	4085
BP7ES	BPR7EIX	4055
BP7EY	BPR7EIX	4055
BP7HS	BPR7HIX	5944
BP8ES	BPR8EIX	6684
BP8HS	BPR8HIX	6742
BP9ES	BPR9EIX	6853
BPR4FS	UR4IX	7401
BPR5E	BPR5EIX	6597
BPR5E-11	BPR5EIX-11	2115
BPR5ES	BPR5EIX	6597
BPR5EY	BPR5EIX	6597
BPR5FS	UR5IX	7177
BPR6E	BPR6EIX	6637
BPR6E-11	BPR6EIX-11	3903
BPR6ES	BPR6EIX	6637
BPR6ES-11	BPR6EIX-11	3903
BPR6EY	BPR6EIX	6637
BPR6EY-11	BPR6EIX-11	3903
BPR6HS	BPR6HIX	4085
BPR6HSA	BPR6HIX	4085
BPR7E	BPR7EIX	4055
BPR7ES	BPR7EIX	4055
BPR7HS	BPR7HIX	5944
BPR8ES	BPR8EIX	6684
BPR8HS	BPR8HIX	6742
BPR8HSA	BPR8HIX	6742



Iridium IX Range



Standard	Iridium	Order No.
BPR9ES	BPR9EIX	6853
BR10ECM	BR10ECMIX	3006
BR10ES	BR10EIX	6801
BR10EYA	BR10EIX	6801
BR6HS	BR6HIX	3419
BR7ES	BR7EIX	6664
BR7HS	BR7HIX	7067
BR8ECM	BR8ECMIX	3520
BR8ES	BR8EIX	5044
BR8HS	BR8HIX	7001
BR9ECM	BR9ECMIX	2707
BR9ECS	BR9ECSIX	5438
BR9ECS-5	BR9ECSIX-5	6014
BR9ES	BR9EIX	3981
BR9EYA	BR9EIX	3981
BR9HS	BR9HIX	5687
C5HSA	CR5HIX	7120
C6HSA	CR6HIX	7274
C7E	CR7EIX	7385
C7HSA	CR7HIX	7544
C8E	CR8EIX	4218
C8EH-9	CR8EHIX-9	3797
C8HSA	CR8HIX	7669
C9E	CR9EIX	3521
C9EH-9	CR9EHIX-9	6216
CR10E	CR10EIX	6482
CR5HSA	CR5HIX	7120
CR6HS	CR6HIX	7274
CR6HSA	CR6HIX	7274
CR7E	CR7EIX	7385
CR7HS	CR7HIX	7544
CR7HSA	CR7HIX	7544
CR8E	CR8EIX	4218
CR8EH-9	CR8EHIX-9	3797
CR8HS	CR8HIX	7669
CR8HSA	CR8HIX	7669
CR9E	CR9EIX	3521
CR9EH-9	CR9EHIX-9	6216
D8EA	DR8EIX	6681
D9EA	DR9EIX	4772
DCP6E	DCPR6EIX	8196
DCP7E	DCPR7EIX	6046
DCPR6E	DCPR6EIX	8196
DCPR7E	DCPR7EIX	6046
DCPR7E-N-10	DCPR7EIX	6046
DCPR8E	DCPR8EIX	6546
DCPR9E	DCPR9EIX	2316

Standard	Iridium	Order No.
DP7EA-9	DPR7EIX-9	7803
DP8EA-9	DPR8EIX-9	2202
DP9EA-9	DPR9EIX-9	5545
DPR7EA-9	DPR7EIX-9	7803
DPR8EA-9	DPR8EIX-9	2202
DPR9EA-9	DPR9EIX-9	5545
DR7EA	DR7EIX	5686
DR7ES	DR7EIX	5686
DR8EA	DR8EIX	6681
DR9EA	DR9EIX	4772
ER8EH	ER8EHIX	8201
ER8EH-N	ER8EHIX	8201
ER9EH	ER9EHIX	96652
FR5CP	BKR5EIX	6341
J9A	DR9EIX	4772
JR8B	DR8EIX	6681
JR8C	DR8EIX	6681
JR9B	DR9EIX	4772
JR9C	DR9EIX	4772
LFR5BP-11	LFR5AIX-11	4469
LR8A	CR8HIX	7669
XR5	XR5IX	7355
ZFR5F-11	ZFR5FIX-11	2477
ZFR5J-11	ZFR5FIX-11	2477
ZFR6F-11	ZFR6FIX-11	6441
ZFR6J-11	ZFR6FIX-11	6441



RACING



IGNITION PARTS

▶ Choosing a Heat range

▶ Heat range of spark plugs

The firing end of the spark plug is exposed in the combustion chamber, so it undergoes the cycle of heat receiving and heat dissipation repeatedly. "Heat rating" is measure of the balance of the amount of heat received and amount of heat dissipated. You need to choose heat rating at which the spark plug can be used normally by maintaining this balance.

▶ Hot type and Cold type

We call spark plugs which firing end heats up quickly, "hot type". On the other hand, we call spark plugs which firing end doesn't heat up quickly, "cold type". As for hot type, since the insulator nose is long and the heat receiving area of the insulator is large, it is heated to higher temperature easily. A Cold type is the opposite.

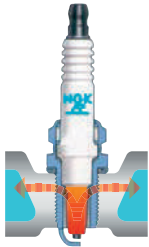
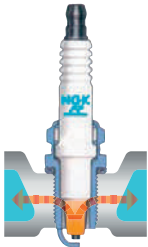
		Hot Type (Low heat rating)	Cold Type (High heat rating)
Flow of heat			
Length of insulator nose		Long	Short
Heat receiving area of the firing end		Large	Small
Spark plug temperature		Rises easily	Does not rise easily
Characteristics of spark plug	Merits	Does not easily lead to carbon fouling	Does not overheat easily
	Demerits	Overheats easily	Easily leads to carbon fouling

It is essential to use a spark plug with a heat rating that matches a specific engine and its condition of use.

If you use spark plugs with a wrong heat rating, following troubles may occur.

You are recommended to consult with a shop/garage where you are normally maintaining your car.

When the heat rating is too low,

The spark plug temperature rises too high and induces abnormal combustion (pre-ignition); this leads to melting of the spark plug electrode that could cause problems such as piston seizure.

Overheat



When the heat rating is too high,

The spark plug temperature remains too low and causes carbons to build up on the firing end; the carbons provide an electrical leakage path that gives rise to a reduction of spark.

Smolder







▶ Choosing a firing end design

▶ About firing end designs

You need to choose racing spark plugs with the appropriate firing end design according to the tune-up level of the engine and the running condition of the vehicle.

In general, spark plugs which firing end projects into the combustion engine have better ignitability. But the other hand, the longer projections are more susceptible to the wear and tear of extreme temperatures.

Since high-power and high-performance engines not only run hotter but also they vibrate more, we recommend choosing a firing end design that reduces exposure of the electrode and insulator as much as possible.

Projected type	Conventional type	Oblique electrode type	Flat type	Semi-surface discharge type
				
Long ground electrode (Projected type)		short		none
low		medium		high

Tune-up level



Spark Plug Maintenance

▶ How to correctly install spark plugs

You must take great care when installing spark plugs. In particular, you have to watch the torque. If you use too much or too little torque when installing spark plugs you can cause damage to the spark plugs and the engine, so be sure you abide by the following.

▶ Be sure to use the correct spark plug wrench.

Some engines have narrow spark plug holes thereby preventing the spark plugs from being tightened correctly with a plug wrench that does not perfectly fit the hexagonal portion of the plug. So, please use the appropriate spark plug wrench for your engine.

▶ Be sure to tighten the spark plug to the correct torque.

Screw in the spark plug and then use a torque wrench to tighten the spark plug to the standard torque noted in the chart on the right. If you do not have access to a torque wrench screw in the plug with your fingertips and then tighten to the rotation angle noted below (corresponds to the tightening torque in the chart on the right) using a spark plug wrench once the spark plug comes in contact with the spark plug tube gasket mount.

Standard Torque

Plug thread size	Tightening torque
φ18mm	35~40N·m (3.5~4.0kgm)
φ14mm	25~30N·m (2.5~3.0kgm)
φ12mm	15~20N·m (1.5~2.0kgm)
φ10mm	10~12N·m (1.0~1.2kgm)
φ8mm	8~10N·m (0.8~1.0kgm)

Conical seat type (without gasket)

Tightening torque	
	10~20N·m (1.0~2.0kgm)



If any lubricants, such as grease, or seizure prevention agents are used on the threads there is a danger of over tightening the spark plug past the standard torque. Therefore, do not use lubricants or seizure prevention agents on these parts.

▶ Tightening angles

Heat range number enters

Thread size				New gasket	Used gasket	
φ18mm·φ14mm (except▼)				$\frac{1}{2} \sim \frac{2}{3}$ of a turn (180°~240°)	$\frac{1}{12}$ of a turn (30°)	
▼	BCPR [○] ED BKR [○] EKUC PZFR [○] C	BCPR [○] EDIX BKR [○] EKUD R6918C [○]	BCPR [○] EKD BKR [○] ETUA	$\frac{1}{3}$ of a turn (120°)	$\frac{1}{12}$ of a turn (30°)	
φ12mm (except▼)				$\frac{1}{2}$ of a turn (180°)	$\frac{1}{12}$ of a turn (30°)	
▼	DILKAR [○] G11DS DILKAR [○] P8SY DILZKR [○] A11DS DPR [○] EA-9S ILZKAR [○] H8S ILZKR [○] B11GS LKR [○] AP7JDS LKR [○] AHX-S LKR [○] DIX-11S SILZKAR [○] F7S SILZKR [○] C11DS R2556G [○]	DILKAR [○] G11GS DILZKAR [○] C11H DILZKR [○] A11GS ILKAR [○] K11S ILZKAR [○] J8SY ILZKR [○] B-11S LKR [○] ARX-PS LKR [○] ARX-PS SILKAR [○] C6DS SILZKAR [○] H6S SILZKR [○] C11S R2558E [○]	DILKAR [○] H11GS DILZKAR [○] C11S DILZKR [○] B10DS ILZKAR [○] E11S ILZKER [○] A4DS ILZKR [○] B8S LKR [○] BGP-S LKR [○] BGP-S SILKRA [○] S SILZKBRO [○] B8S SILZKR [○] F11DS	$\frac{1}{4}$ of a turn (90°)	$\frac{1}{8}$ of a turn (45°)	
φ10mm (except▼)				$\frac{1}{2}$ of a turn (180°)	$\frac{1}{12}$ of a turn (30°)	
▼	C [○] E CPR [○] EAIX-9 CR [○] EGP CR [○] EIB-9 CR [○] EKB DIMR [○] A10 ILMAR [○] B8 LMAR [○] AI-10 LMAR [○] AP8J LMAR [○] DI-10 LMAR [○] F-9 LZMAR [○] AI-10 MR [○] BI-8 MR [○] E-9 MR [○] K-9 SILMAR [○] B9 SILMFR [○] A8G	CPR [○] E CPR [○] EB-9 CR [○] EIA-10 CR [○] EIX CR [○] EKC DIMR [○] B10 ILMAR [○] E9 LMAR [○] AI-8 LMAR [○] BI-9 LMAR [○] D-J LMAR [○] FI-10G MAR [○] A-6J MRO [○] C-9N MRO [○] F PMR [○] A SILMAR [○] C9 SIMR [○] A9	CPR [○] EA-9 CR [○] E CR [○] EIA-9 CR [○] EK CR [○] EKPA DIMR [○] C10 ILMAR [○] F8 LMAR [○] AI-8E LMAR [○] C-9 LMAR [○] EI-7 LMAR [○] G MAR [○] A-J MRO [○] CI-8 MRO [○] G-9E PMR [○] B SILMAR [○] E9 ZMR [○] A-10	CPR [○] EAGP-9 CR [○] EB CR [○] EIB-10 CR [○] EKA CR [○] EVX ILMAR [○] A8 LMAR [○] A-9 LMAR [○] AIX-P LMAR [○] CI-8 LMAR [○] E-J LMAR [○] J-9E MRO [○] AI9 MRO [○] D-9 MRO [○] J-9 PMR [○] C-H SILMAR [○] F9 ZMR [○] AP	$\frac{1}{4}$ of a turn (90°)	$\frac{1}{12}$ of a turn (30°)
▼	CPR [○] EA-9S CR [○] EDX-9S ILMAR [○] D8S LMAR [○] A-9S LMAR [○] K-9S MR [○] B-9NS SILMAR [○] D9DS SPMR [○] A6HDG R0465B [○]	CPR [○] EAIX-9S CR [○] EH-9S IMR [○] C-9HES LMAR [○] ADX-9S LMDR [○] A-JS MR [○] BP8HJS SILMFR [○] B8GS R0409B [○]	CPR [○] EDX-9S DILMAR [○] A11S IMR [○] D-9H LMAR [○] AP8JS MAR [○] B-JDS SILMAR [○] A9S SILR [○] A7S R0451B [○]	CR [○] EDX-S ILMAR [○] C9D IMR [○] E-9HES LMAR [○] H-9DS MR [○] AP8HJS SILMAR [○] C9S SIMR [○] B9DS R0451C [○]	$\frac{1}{6}$ of a turn (60°)	$\frac{1}{12}$ of a turn (30°)
φ8mm (except▼)				$\frac{1}{3}$ of a turn (120°)	$\frac{1}{12}$ of a turn (30°)	
Conical seat type (without gasket)				$\frac{1}{16}$ of a turn (22.5°)	$\frac{1}{16}$ of a turn (22.5°)	
▼ Copper gasket type				$\frac{1}{12}$ of a turn (30°)	$\frac{1}{24}$ of a turn (15°)	



▶ ϕ 14mm×19mm(Hex20.8mm)



R6918B-○



Heat range	7	8	9
Spark plug type	B-E		
Terminal shape			
Center electrode material	Platinum		
Ground electrode material	Nickel		



R7376-○



Heat range	7	8	9	10
Spark plug type	B-E			
Terminal shape				
Center electrode material	Iridium			
Ground electrode material	Platinum			



R6712-○



Heat range	9	10
Spark plug type	B-E	
Terminal shape		
Center electrode material	Nickel	
Ground electrode material	—	

▶ ϕ 14mm×22mm(Hex16.0mm)



R7282A-○^{※1}



Heat range	10	105	11
Spark plug type	Short		
Terminal shape			
Center electrode material	Iridium		
Ground electrode material	Platinum		

※ 1) It's necessary to use special plug caps(Please refer to page 8)

※ 2) The length from gasket to terminal of ISO/JIS type spark plugs is 50.5mm which is 2.5mm shorter than old JIS type spark plugs.

※ 3) Heat range number enters ○

※ 4) Racing spark plugs may be finished selling without notice.

NOTICE) = Solid post terminal = Thread terminal with nut = Thread terminal



▶ $\phi 14\text{mm} \times 19\text{mm}$ (Hex16.0mm)

Please be aware that some plugs cannot be replaced despite having the same thread size and length.

R7282-  ※1



Heat range	9	10	105	11
Spark plug type	Short			
Terminal shape				
Center electrode material	Iridium			
Ground electrode material	Platinum			

R7433- 



Heat range	8	9	10
Spark plug type	BK-E (ISO/JIS) ※2		
Terminal shape			
Center electrode material	Iridium		
Ground electrode material	Nickel		

R7434- 



Heat range	8	9	10
Spark plug type	BK-E (ISO/JIS) ※2		
Terminal shape			
Center electrode material	Iridium		
Ground electrode material	Platinum		

R6601- 



Heat range	8	9	10	11
Spark plug type	BK-E (ISO/JIS) ※2			
Terminal shape				
Center electrode material	Nickel			
Ground electrode material	—			

R7435- 



Heat range	8	9	10
Spark plug type	BCP-E (old JIS)		
Terminal shape			
Center electrode material	Iridium		
Ground electrode material	Nickel		

R7436- 



Heat range	8	9	10
Spark plug type	BC-E (old JIS)		
Terminal shape			
Center electrode material	Iridium		
Ground electrode material	Platinum		

R6690- 



Heat range	9	10	11
Spark plug type	BC-E (old JIS)		
Terminal shape			
Center electrode material	Nickel		
Ground electrode material	—		



▶ ϕ 14mm×26.5mm(Hex16.0mm)



R7437-○



Heat range	8	9	10
Spark plug type	LFR long reach		
Terminal shape			
Center electrode material	Iridium		
Ground electrode material	Nickel		



R7438-○



Heat range	8	9	10
Spark plug type	LFR long reach		
Terminal shape			
Center electrode material	Iridium		
Ground electrode material	Platinum		

▶ ϕ 14mm×21.5mm(Hex20.8mm)



R6725-○



Heat range	9	10	105	11	115
Spark plug type	Rotary Engine RX-7				
Terminal shape					
Center electrode material	Platinum				
Ground electrode material	Platinum				



R7420-○



Heat range	9	10	105	11
Spark plug type	Rotary Engine RX-7			
Terminal shape				
Center electrode material	Iridium			
Ground electrode material	Platinum			

▶ ϕ 14mm×21mm(Hex20.8mm)



R7440A-○L



Heat range	9	10
Spark plug type	Rotary Engine RX-8 Lside	
Terminal shape		
Center electrode material	Iridium	
Ground electrode material	Platinum	

▶ ϕ 14mm×19mm(Hex20.8mm)



R7440B-○T



Heat range	10	11
Spark plug type	Rotary Engine RX-8 Tside	
Terminal shape		
Center electrode material	Iridium	
Ground electrode material	Platinum	

▶ ϕ 12mm×26.5mm(Hex16.0mm)



R2556G-○



Heat range	8	9	10
Spark plug type	LKR long reach		
Terminal shape			
Center electrode material	Iridium		
Ground electrode material	Platinum		

▶ ϕ 12mm×26.5mm(Hex14.0mm)



R2558E-○



Heat range	8	9	10
Spark plug type	LKAR long reach		
Terminal shape			
Center electrode material	Iridium		
Ground electrode material	Platinum		

▶ ϕ 12mm×19mm(Hex16.0mm)



R2349-○



Heat range	9	10	11
Spark plug type	DC-E		
Terminal shape			
Center electrode material	Nickel		
Ground electrode material	—		



R2525-○



Heat range	9	10
Spark plug type	DC-E	
Terminal shape		
Center electrode material	Platinum	
Ground electrode material	Nickel	

▶ ϕ 10mm×26.5mm(Hex16.0mm)



R0452A-○



Heat range	10
Spark plug type	LMR long reach
Terminal shape	
Center electrode material	Nickel
Ground electrode material	—

▶ ϕ 10mm×26.5mm(Hex14.0mm)



R0465B-○



Heat range	10
Spark plug type	LMAR long reach
Terminal shape	
Center electrode material	Nickel
Ground electrode material	—



R0451B-○



Heat range	8
Spark plug type	LMAR long reach
Terminal shape	
Center electrode material	Iridium
Ground electrode material	Nickel



R0451C-○



Heat range	10
Spark plug type	LMAR long reach
Terminal shape	
Center electrode material	Iridium
Ground electrode material	Nickel

※ 1) Heat range number enters ○

※ 2) Racing spark plugs may be finished selling without notice.

NOTICE) = Solid post terminal = Thread terminal with nut = Thread terminal



▶ ϕ 10mm×19mm(Hex16.0mm)



R0373A-○



Heat range	8	9	10	11
------------	---	---	----	----

Spark plug type	C-E
Terminal shape	
Center electrode material	Iridium
Ground electrode material	Platinum



R0045Q-○



Heat range	10	11
------------	----	----

Spark plug type	C-E
Terminal shape	
Center electrode material	Nickel
Ground electrode material	—

▶ ϕ 10mm×19mm(Hex16.0mm) Half thread



R0409B-○



Heat range	8	9	10
------------	---	---	----

Spark plug type	C-EH
Terminal shape	
Center electrode material	Iridium
Ground electrode material	Nickel



R0459A-○



Heat range	10
------------	----

Spark plug type	C-EH
Terminal shape	
Center electrode material	Nickel
Ground electrode material	—

▶ ϕ 8mm×19mm(Hex13.0mm) Half thread



R847-○



Heat range	10	11
------------	----	----

Spark plug type	E-EH
Terminal shape	
Center electrode material	Nickel
Ground electrode material	—

※ 1) Heat range number enters ○
 ※ 2) Racing spark plugs may be finished selling without notice.

NOTICE) = Solid post terminal = Thread terminal with nut = Thread terminal





▶ Discontinued plug types

Red color indicates non resistor plugs. Heat range number enters

Old part number	New part number	Old part number	New part number
R0045G-, R0045J-	→ R0045Q-	R6179A-	→ R7282-
R016-, R017-	→ R0373A-	R6255-, R6255F-, R6326-	→ R7433-
R0161-	→ CR HIX	R6205-, R6241-	→ R7433- or R7434-
R216-, R217-	→ R2525-	R6206-, R6242-	→ R7434-
R2270-, R2430-	→ R2349-	R5400-, R5400F-, R6337-	→ R7435-
R2556B-	→ R2556G-	R5686-	→ R7435- or R7436-
R2558A-	→ R2558E-	R5830-, R5687-	→ R7436-
R4304A-	→ BPR EIX	R7112-, R7113-	→ R7433-
R5530, R5525-	→ BR HIX	R7114-, R7115-	→ R7433- or R7434-
R5649-	→ R6712-	R7116-, R7117-	→ R7434-
R6711-	→ R6601-	R7118-, R7119-	→ R7434-
R5883-	→ R6690-	R7232-, R7233-	→ R7435-
R4630A-, R6385-P	→ R7376-	R7234-, R7235-	→ R7435- or R7436-
R6120-	→ R7282-	R7236-, R7237-	→ R7436-
R6120A-	→ R7282A-	R7238-, R7239-	→ R7436-

▶ Racing spark plug caps

Heat range number enters

Plug cap number(color)	Plugs and cables
 TRS1225-B (Blue) ※for HONDA RACE	R7282-, R7282A- φ 8mm Cable
 TRS1233A-R (Red) TRS1233B-Y (Yellow) TRS1233C-G (Green)	R7282-, R7282A- φ 7mm Cable



▶ Motorcycles

Heat range number enters

Displacement	Model	Spark plug Number	Racing spark plug	other applicable plug number on page (check colour code)
▶ APRILIA				
1000	RSV4 Factory	CR9EB	R0373A-	120
125	RS4 125	CR9EB	R0373A-	
▶ BMW				
1000	S1000RR	LMAR9D-J	R0451C-,R0465B-	119
▶ DUCATI				
1199	1199 Panigale	MAR9A-J	-	-
▶ HONDA				
1000	CBR1000RR ('08.7~)	IMR9E-9HES	R0409B-,R0459A-	120
	CBR1000RR SP	IMR9E-9HES	R0409B-,R0459A-	
	CBR1000RR SP2	SILMAR10C9S	R0451C-,R0465B-	
600	CBR600RR ('09~)	IMR9E-9HES	R0409B-,R0459A-	120
450	CRF450R ('08.10~)	SILMAR9A9S	R0451C-	119
	CRF450RX	SILMAR9A9S	R0451C-	
250	CBR250R ('88.5~)	CR9EH-9	R0409B-	120
	CBR250R ('11.3~)	SIMR8A9	R0373A-	120
	CBR250RR ('91.1~)	CR9EH-9	R0409B-	120
	CBR250RR ('17.5~)	SILMAR8C9	R0451C-	119
	CRF250R ('04.8~'09.8)	R0409B-8	R0409B-	120
	CRF250R ('09.8~)	R0451B-8	R0451B-	119
	NSF250R	R0452A-10	R0452A-,R0451C-	119
	VTR	CR8EH-9	R0409B-	120
	150	CRF150R/R II	CR8EH-9	R0409B-
125	CBR125R	CR8E	R0373A-	120
	CRF125F	DPR8EA-9	-	-
100	CRF100F	CR7HSA	-	-
	NSF100	CR8HSA	-	-
85	CR85R	BR10EG	R7376-	116
50	NSR mini	BR8ES	R7376-	
▶ HUSQVARNA				
450	FC450	LKAR8AI-9	R2558E-	118
350	FC350	LKAR8AI-9	R2558E-	
250	FC250	LKAR8AI-9	R2558E-	
	FE250	CR9EKB	R0373A-	120
125	TE250/TC250	CR8EB	R0373A-	116
	TC125	BR9EG	R7376-	
85	TC85	BR9ECMVX	-	-
▶ KAWASAKI				
1000	Ninja ZX-10R ('04~'15)	CR9EIA-9	R0373A-,R0045Q-	120
	Ninja ZX-10R ('16.10~)	SILMAR9B9	R0451C-,R0465B-	119
600	ZX-6R	CR9E	R0373A-,R0045Q-	120
450	KX450F	CPR8EB-9	R0373A-	
250	KX250F ('11~)	CPR8EB-9	R0373A-	120
	KX250F ('05.9~'10)	CR8E	R0373A-	
	Ninja250 ('18.2~)	SILMAR9B9	R0451C-	119
	Ninja250 ('13.2~18.2)	CR8E	R0373A-	
	Ninja250R	CR8E	R0373A-	120
	Ninja250SL	MR8C1-8	R0373A-	
	Z250	CR8E	R0373A-	



Technical
Partner**CAUTION**

Choose appropriate heat range and firing end of racing spark plugs according to engine modification or driving condition.
(Please refer to page 114)

Heat range number enters

Displacement	Model	Spark plug Number	Racing spark plug	other applicable plug number on page (check colour code)	
► KAWASAKI					
85	KX85/II	R6252K-105	R7376-	116	
65	KX65	BR10EG	R7376-		
► KTM					
450	450SMR ('08~'12)	CR9EKB	R0373A-*	120	
	450SMR ('13~)	LKAR8A-9	R2558E-	118	
	450SX-F	CR9EKB	R0373A-*	120	
390	RC390	LKAR8A-9	R2558E-	118	
350	350SX-F	LMAR9A-8	R0451C-	119	
250	250DUKE ('18~)	LKAR8A-9	R2558E-	118	
	250EXC	BR7ES	R7376-	116	
	250EXC-F ('06~)	CR9EKB	R0373A-*	120	
	250EXC-F ('17~)	LMAR9A-10	R0451C-	119	
	250SX-F ('06~'12)	CR9EKB	R0373A-*	120	
	250SX-F ('13~)	LMAR9A-8	R0451C-	119	
	RC250/R	LKAR8A-9	R2558E-	118	
	125	125SX ('08~)	BR9ECMVX	-	-
85	85SX ('07~)	BR9ECMVX	-	-	
65	65SX ('03~'08)	BR8ECM	-	-	
	65SX ('09~)	LR8B	-	-	
50	50SX ('10~)	LR8B	-	-	
► SUZUKI					
1000	GSX-R1000 ('07~)	CR9EIA-9	R0373A-, R0045Q-	120	
600	GSX-R600 ('08~)	CR9EIA-9	R0373A-, R0045Q-		
450	RM-Z450 ('07.10~)	DIMR8A10	R0373A-*		
250	RM250 ('01.6~)	BR8EG	R7376-	116	
	RM-Z250 ('07~'12)	CR8EIA-10	R0373A-	120	
	RM-Z250 ('13~)	CR8EIB-10	R0373A-*		
125	RM125 ('96.8~)	R6918B-8	R6918B-	116	
85	RM85L	BR10ES	R7376-	-	
50	DR-Z50	CR7HS	-	-	
► TRIUMPH					
675	Daytona 675R	CR9EIA-9	R0373A-	120	
► YAMAHA					
1000	YZF-R1 ('04~'08)	CR9EK	R0373A-, R0045Q-	120	
	YZF-R1 ('09~)	LMAR9E-J	R0451C-, R0465B-	119	
600	YZF-R6	CR10EK	R0373A-, R0045Q-	120	
450	YZ450F/FX	CR8E	R0373A-	119	
300	YZF-R3 ('18.3~)	LMAR8A-9	R0451C-		
	YZF-R3 ('15~'18)	CR8E	R0373A-	120	
250	YZ250	BR8EG	R7376-	116	
	YZF-R25 ('18~)	LMAR8A-9	R0451C-	119	
	YZF-R25 ('15~'17)	CR9E	R0373A-	120	
	YZ250F ('19~)	LMAR9E-J	R0451C-	119	
	YZ250F ('14~'18)	LMAR8G	R0451C-		
	YZ250F ('01~'13)	CR8E	R0373A-	120	
	YZ250FX	LMAR8G	R0451C-	119	
	WR250R/X	CR9EK	R0373A-	120	
	125	YZ125 ('05.7~)	BR9EVX	R7376-	116
	85	YZ85/LW	BR10EG	R7376-	-
50	TT-R50E	CR7HSA	-	-	



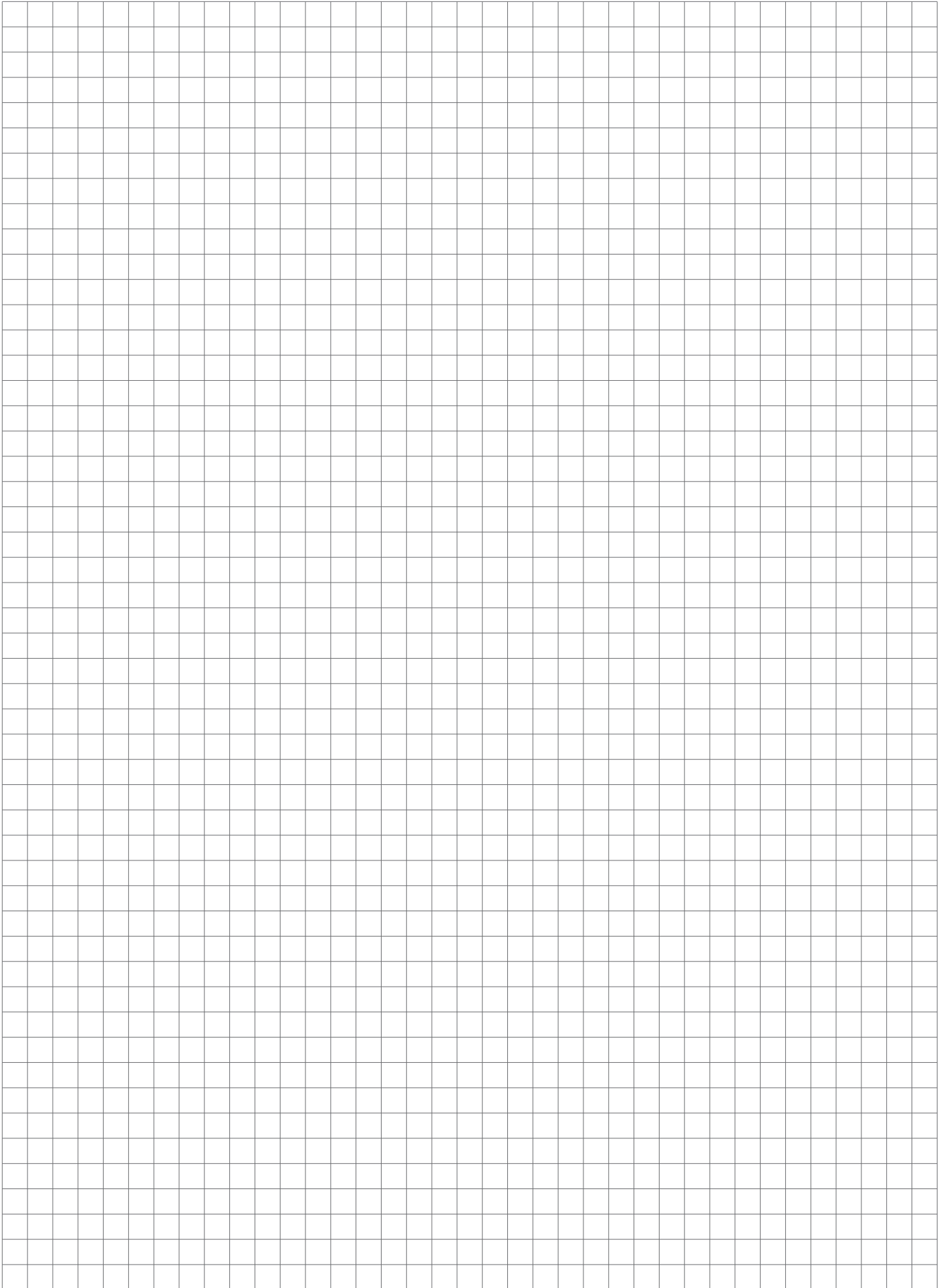

SERIES



IGNITION
PARTS

SERIES OF NGK SPARK PLUGS

NGK ZÜNDKERZEN · SÉRIES DES BOUGIES NGK

SERIES DE BUJÍAS DE ENCENDIDO NGK · TYPBETECKNINGAR FÖR NGK TÄNDSTIFT

STANDARD TYPES

STANDARD AUSFÜHRUNGEN
TIPOS ESTANDARES

TYPES STANDARDS
STANDARDTYPER

	NON-RESISTOR NON-RÉSISTANCE ICKERESISTOR	OHNE WIDERSTAND NO-RESISTOR	RESISTOR RÉSISTANCE RESISTOR	MIT WIDERSTAND RESISTOR		
ϕ 14mm × 9.5mm Hex 20.8mm Fig. ① a	B-2 B-4 B6S B7S B8S		BR6S			
		Fig. ① c		BP-4 BP5S BP6S		
ϕ 14mm × 19.0mm Hex 20.8mm Fig. ② a	B4ES B5ES B6ES,-11 B7ES,-11 B8ES B9ES B10ES		BR4ES BR5ES BR6ES,-11 BR7ES BR8ES,-11 BR9ES BR10ES			
		Fig. ② b		BR6EB-L-11		
		Fig. ② h		BR8EYA BR9EYA BR10EYA		
		Fig. ② c	BP2ES, BP-2E BP4ES,-11 BP5ES,-11,-13 BP6ES,-11 BP7ES,-11 BP8ES BP9ES	BP5ESZ BP6ESZ	BPR2ES, BPR-2E BPR4ES,-11,-13 BPR5ES,-11,-13 BPR6ES,-5,-11 BPR7ES,-11 BPR8ES,-6 BPR9ES	
					Fig. ③ e	BPR6EKN BPR7EKN
		Fig. ② f	BP4EY,-11 BP5EY,-11 BP6EY,-11 BP7EY		BPR4EY,-11 BPR5EY,-11 BPR6EY,-11 BPR7EY-11	
		Fig. ② j	BP5E BP6E		BPR4E,-11 BPR5E,-11 BPR6E,-11 BPR7E	
		Fig. ④ g	BP5ET,-10 BP6ET BP7ET			
Fig. ⑤ i			BPR5EJ			
ϕ 14mm × 19.0mm Hex 16.0mm Fig. ⑥ c	BCP4ES,-11 BCP5ES,-11 BCP6ES,-11 BCP7ES,-11		BCPR5ES,-11 BCPR6ES,-11 BCPR7ES,-11 BCPR9ES-11			
		Fig. ⑧ g	BCP5ET BCP6ET BCP7ET	BCPR5ET BCPR6ET BCPR7ET		
		Fig. ⑥ a	BC6ES	BCR8ES		
		Fig. ⑦ c	BK5ES	BK5ESZ	BKR4ES-11 BKR5ES,-11 BKR6ES,-11 BKR7ES-11	

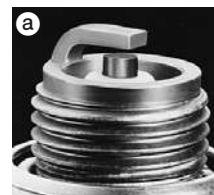
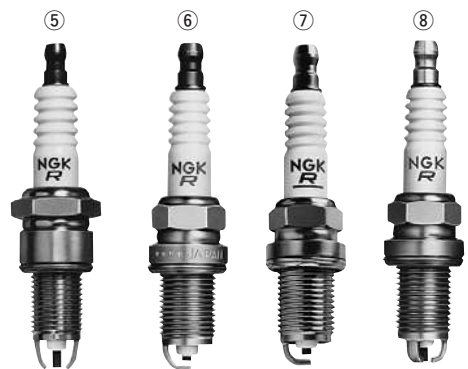



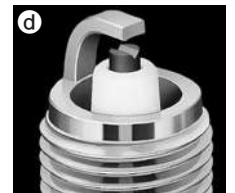
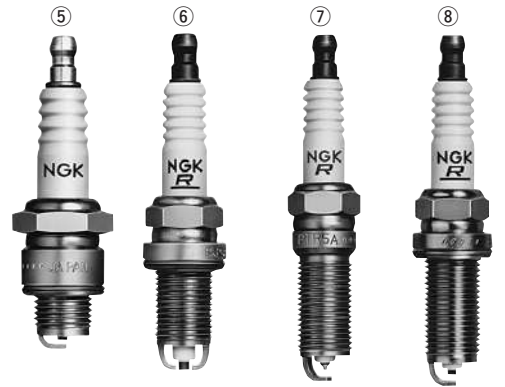
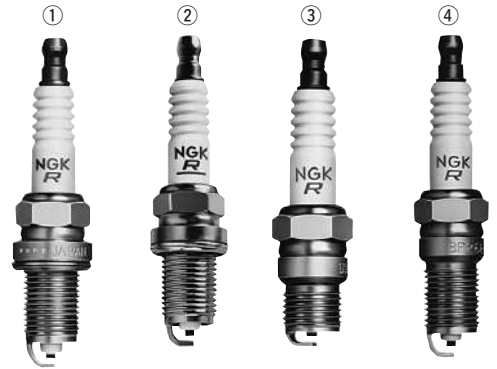

	NON-RESISTOR NON-RÉSISTANCE ICKERESISTOR	OHNE WIDERSTAND NO-RESISTOR	RESISTOR RÉSISTANCE RESISTOR	MIT WIDERSTAND RESISTOR
ϕ 14mm × 19.0mm Hex 16.0mm Fig. ①③			BCPR4EY,-11 BCPR5EY,-11 BCPR6EY,-11,-N-11 BCPR7EY,-11,-N-11	
	Fig. ②④ ISO		BKR4EY,-11 BKR5EY,-11 BKR5EYA,-11 BKR6EY,-11 BKR6EYA,-11 BKR7EY	
	Fig. ①④	BCP5E BCP6E,-11 BCP7E,-11	BCPR5E,-11 BCPR6E,-11 BCPR7E,-11	
	Fig. ②④ ISO	BK5E,-11 BK6E,-11	BKR4E,-11 BKR5E,-11,-N,-N-11 BKR5EZ BKR6E,-11-E,-N,-N-11 BKR6EZ BKR7E,-11,-N-11 BKR8E-11 FR6F-11DK FR6F-11K	
	Fig. ⑥⑦ ISO		BKR5EK BKR6EK	
Fig. ⑥⑧ ISO		BKR5EKB-11 BKR6EKB-11		
			BKR5EKC BKR6EKC,-N-11 BKR6EKE BKR7EKC,-N,-N-11	
ϕ 14mm × 26.5mm Hex 16.0mm Fig. ⑧④			LFR4A,-11 LFR4A-E LFR5A,-11 LFR6A,-11 LFR7A	
ϕ 14mm × 11.2mm Conical seat Hex 16.0mm Fig. ③①		B7FS	BR5FS BR6FS,-15	
	Fig. ③②	BP4FS BP5FS BP6FS BP7FS	BPR4FS,-11,-15 BPR5FS,-11,-15 BPR6FS	
	Fig. ③④	BP5F BP6F		
ϕ 14mm × 17.5mm Conical seat Hex 16.0mm Fig. ④①		B8EFS B9EFS	BR7EFS	
	Fig. ④⑤		BR6EF BR7EF	
	Fig. ④②	BP5EFS,-13 BP6EFS,-13 BP7EFS	BPR5EFS,-13 BPR6EFS,-13,-15 BPR7EFS-15	
	Fig. ④④	BP6EF	BPR6EF,-11,-13	
ϕ 14mm × 25.0mm Conical seat Hex 16.0mm Fig. ⑦②			TR5A-13 TR5B-13 TR6B-10	
ϕ 14mm × 11.2mm Hex 20.8mm Fig. ⑤①		B-4L B-6L B6LY (Fig. ⑤⑤)		

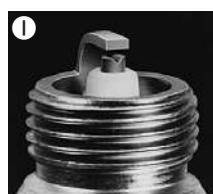
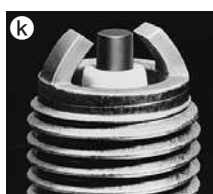
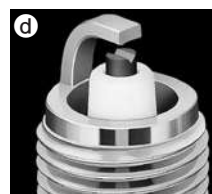





	NON-RESISTOR NON-RÉSISTANCE ICKERESISTOR	OHNE WIDERSTAND NO-RESISTOR	RESISTOR RÉSISTANCE RESISTOR	MIT WIDERSTAND RESISTOR	
ϕ 14mm \times 12.7mm Hex 20.8mm Fig. ①(a)	B-2H B-4H,-10 B5HS B6HS,-10 B7HS,-10 B8HS,-10 B9HS B10HS		BR4HS BR5HS BR6HS,-10 BR7HS,-10 BZ7HS-10 BR8HS,-10 BR9HS,-10		
	Fig. ①(b)	BP2HS BP4HS,-10 BP5HS,-10 BP6HS,-10 BP6HSA BP7HS,-10 BP8HS,-10,-15	BP-2H BP-4H BP6H BP7H	BPR2HS BPR4HS,-10 BPR4HSA BPR-4H BPR5HS BPR6HS,-10 BPR6HSA BPR7HS,-10 BPZ8H-N-10 BPR8HS,-10 BPR8HSA BPZ8HS-10,-15	
	Fig. ①(c)	BP4HA			
	Fig. ①(e)	B6HSA B8HSA		BR4HSA BR6HSA,-9 BR8HSA,-9	
ϕ 18mm \times 12.0mm Hex 20.8mm Fig. ⑤(f)	AB-2 AB-6 AB-7 AB-8				
ϕ 18mm \times 16.0mm Hex 25.4mm			R8102B-10		
ϕ 12mm \times 19.0mm Hex 18.0mm Fig. ⑥(h)	D6EA D7EA D8EA D9EA D10EA		DR7EA DR7EB DR8EA DR8EB DR9EA		
	Fig. ⑥(i)	DP6EA-9 DP7EA-9 DP8EA-9 DP9EA-9	DPR5EA-9 DPR6EA-9 DPR6EB-9 DPR7EA-9 DPR8EA-9 DPR9EA-9		
	Fig. ⑥(h)	J9A	JR8B JR9B JR10B		
	Fig. ⑥(k)		JR8C JR9C		
ϕ 12mm \times 21.0mm Hex 18.0mm Fig. ⑦(i)	DP8Z		DPR7Z DPR8Z DPR9Z		
ϕ 12mm \times 19.0mm Hex 16.0mm Fig. ⑧(i)	DCP6E DCP7E		DCPR6E DCPR7E,-N DCPR8E,-N DCPR9E	KR6A-10 KR8C-G KR9C-G	
	Fig. ⑧(m)			DCPR8EKC	
ϕ 12mm \times 20.5mm Hex 16.0mm			KER7A-8DEG		
ϕ 12mm \times 26.5mm Hex 16.0mm Fig. (b)			LKR6C LKR6E LKR6F-10 LKR7E		
ϕ 12mm \times 25.0mm Hex 14.0mm			LNAR7A-9G		
ϕ 12mm \times 26.5mm Hex 14.0mm Fig. (b)			LZKAR6C-9 LZKAR7D-9,-9D LKAR8A-9,-9S		

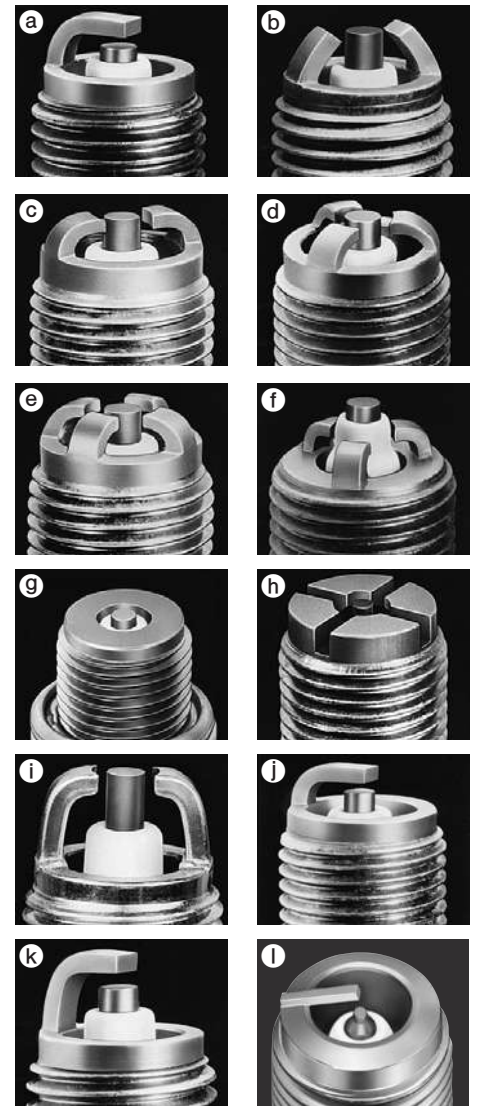

	NON-RESISTOR NON-RÉSISTANCE ICKERESISTOR	OHNE WIDERSTAND NO-RESISTOR	RESISTOR RÉSISTANCE RESISTOR	MIT WIDERSTAND RESISTOR
ϕ 12mm \times 12.7mm Hex 18.0mm Fig. ①a	D6HA D8HA		DR4HS DR5HS DR6HS DR8HS	
ϕ 10mm \times 12.7mm Hex 16.0mm Fig. ②a	C2H C5HSA C6HSA C7HSA C8HSA	C4HSB C5HSB	CR4HSA CR4HSB LR4C-E CR5HSA CR5HSB CR6HSA LR6E CR7HSA LR7D CR8HSA CMR8H LR8A LR8B	
ϕ 10mm \times 19.0mm Hex 16.0mm Fig. ③j	C7E C8E C9E		CR6E CR6EB CR7EK CR7EB CR8EK CR8EB CR9EK CR9EB CR10E	
			D CPR6EA-9S CPR8E CPR7EA-9	
ϕ 10mm \times 19.0mm Hex 16.0mm Fig. ④a	C8EH-9 C9EH-9		CR5EH-9 MR7C-9N MR7E-9 MR7F CR8EH-9 MR8C-9N MR8D-9 MR8E-9 MR8F CR9EH-9 MR9C-9N	
ϕ 10mm \times 19.0mm Hex 16.0mm Fig. ③b			CR7EKB CR7EKB CR8EKB CR8EKB CR9EKB CR9EKB CR10EK	
			CR7EKC	
ϕ 10mm \times 19.0mm Hex 14.0mm Fig. ⑤b			MAR9A-J MAR8B-JDS MAR10A-J MAR9B-JDS	
ϕ 10mm \times 26.5mm Hex 14.0mm Fig. ⑥k			LMAR6A-9 LMAR6C-9 LMAR7A-9 LMAR7H-9DS LMAR8A-7,9,9S LMAR8F-9 LMAR8G	
			LMAR9D-J	
ϕ 8mm \times 19.0mm Hex 13.0mm Fig. ⑤a			ER8EH, -N ER9EH, -N, -6N ER10EH	



FOR ROTARY ENGINE
FÜR WANKELMOTOR **POUR MOTEUR ROTATIF**
PARA MOTOR ROTATIVO **TÄNDSTIFT FÜR WANKELMOTORER**

	NON-RESISTOR NON-RÉSISTANCE ICKERESISTOR	OHNE WIDERSTAND NO-RESISTOR	RESISTOR RÉSISTANCE RESISTOR	MIT WIDERSTAND RESISTOR
ϕ 14mm \times 19.5mm Hex 20.8mm Fig. ⑥c	B7EM		BR8EM	
			BR7ET BR8ET BR9ET BR10ET	
			BR8EQ,-14 BR9EQ,-14	
ϕ 14mm \times 21.5mm Hex 20.8mm Fig. ⑧g			SD10A SD11A	
			BUR6EQ BUR7EQ BUR8EQ BUR9EQ BUR7EQP BUR9EQP	
ϕ 14mm \times 21.0mm Hex 20.8mm Fig. ⑨			RE6C-L RE7C-L RE8C-L	
ϕ 14mm \times 19.0mm Hex 20.8mm Fig. ⑩①			RE9B-T	



SEMI SURFACE DISCHARGE TYPES AND SUPPLEMENTARY GAP TYPE

HALBGLEITFUNKENTYPEN UND ZUSÄTZLICHER ABSTANDSTYP
 TYPE À DÉCHARGE SEMI-SURFACIQUE ET TYPE À ÉCARTEMENT SUPPLÉMENTAIRE
 TIPO DE DESCARGA DE MEDIA SUPERFICIE Y TIPO DE GALGA SUPLEMENTARIA
 STIFT MED SEMI-YTGNISTGAP OCH STIFT AV SUPPLEMENTÄR TYP

	NON-RESISTOR OHNE WIDERSTAND NON-RÉSISTANCE NO-RESISTOR ICKERESISTOR	RESISTOR MIT WIDERSTAND RÉSISTANCE RESISTOR RESISTOR
ϕ 14mm × 12.7mm Hex 20.8mm Fig.①②	BU8H	BUZ8H
ϕ 14mm × 19.0mm Hex 20.8mm Fig.②③		BUR5EA-11 BUR6EA-11 BUR7EA-11
ϕ 14mm × 19.0mm Hex 20.8mm Fig.②④		BUR4EB-11 BUR5EB-11 BUR6EB-11 BUR7EB-11
	Fig.②⑤	BUR5ET,-10 BUR6ET
ϕ 14mm × 19.0mm Hex 20.8mm Fig.③⑥		BPR6EK-A
	Fig.③⑦	BPR5EKU
ϕ 14mm × 17.5mm Conical seat Hex 16.0mm Fig.④⑧	BU6EFSZ	BUR6EFSZ
ϕ 14mm × 19.0mm Hex 16.0mm Fig.⑥⑨ ISO		BKUR6EK,-9 BKUR7EK
	Fig.⑤⑩ ISO	BKUR5ET,-10 BKUR5ETZ-10 BKUR6ET,-10 BKUR6ETB BKUR7ET
	Fig.⑥⑪ ISO	BKR5EKU BKR6EKU BKR7EKU
		BKR6EKUE
	Fig.⑥⑫ ISO	BKR6EKUB
ϕ 14mm × 22.0mm Hex 16.0mm Fig.⑦⑬		BKR5EKUC BKR6EKUC
ϕ 14mm × 19.0mm Hex 16.0mm Fig.⑥⑭		BKR6EQUA

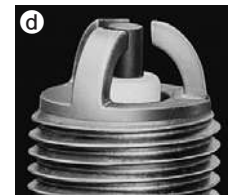
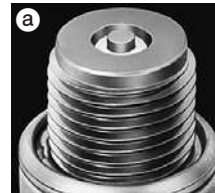
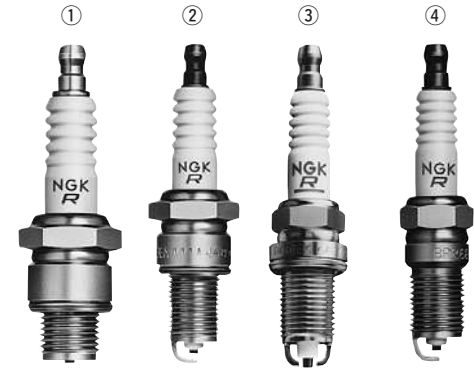

PROJECTED GAP TYPES

ZUNDKERZEN MIT VORSPRINGENDER FUNKENSTRECK

TYPE A ÉCARTEMENT EN SAILLIE

TIPOS DE ABERTURA DE CHISPA PROYECTADA

STIFT MED FÖRLÅNGDA ELEKTRODER

	NON-RESISTOR NON-RÉSISTANCE ICKERESISTOR	OHNE WIDERSTAND NO-RESISTOR	RESISTOR RÉSISTANCE RESISTOR	MIT WIDERSTAND RESISTOR
ϕ 14mm × 19.0mm Hex 20.8mm Fig. ①(a) Fig. ②(b)	BE529Y-11		BRE527Y-11	BRE529Y,-11
			ZGR4A	ZGR5A
ϕ 14mm × 20.5mm Hex 20.8mm Fig. ②(b)			ZGR5B,-11	ZGR6B-11
ϕ 14mm × 22.0mm Hex 20.8mm Fig. ②(c)			ZGR5C	
ϕ 14mm × 19.0mm Hex 16.0mm Fig. ③(b)	ZF6A-11		ZFR5A-11	ZFR6A-11
			ZFR4F-11	ZFR5J-11
			ZFR5F,-11	ZFR6J-11
			ZFR6F-11,G	ZFR7J-11
			ZFR7F-11	ZFR7J-11
ϕ 14mm × 20.5mm Hex 16.0mm Fig. ③(e)			ZFR6K-9E,-11S	
			ZFR5G	ZFR6G
ϕ 14mm × 22.5mm Hex 16.0mm Fig. ③(c)			ZFR4E-11	ZFR5E-11
			ZFR6E-11	ZFR6E-11
ϕ 14mm × 25.0mm Conical seat Hex 16.0mm Fig. ⑤(b)			LZTR4A-11	LZTR5A-13
ϕ 12mm × 19.0mm Hex 16.0mm			ZKR7A-10	
ϕ 12mm × 21.5mm Hex 16.0mm			ZKER6A-10DEG,-10EG	
ϕ 12mm × 26.5mm Hex 16.0mm			LZKR6B-10E	
ϕ 12mm × 26.5mm Hex 14.0mm			LZKAR6C-11	
ϕ 12mm × 26.3mm Bi-Hex 14.0mm			ZKBR7A-HTU	

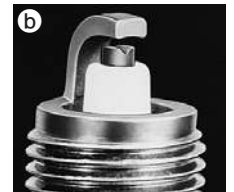
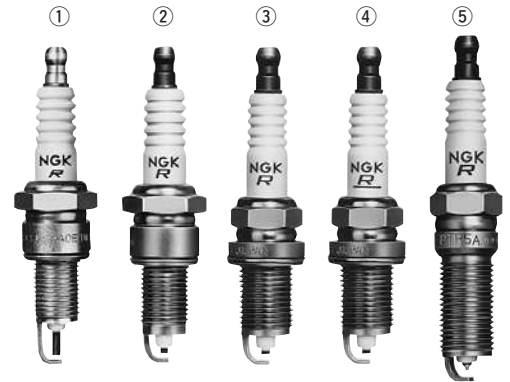

SLANT GROUND ELECTRODE TYPE

SCHRÄGER MASSENELEKTRODENTYP

TYPE À ÉLECTRODE DE MASSE À INCLINAISON

TIPO DE ELECTRODO DE MASA INCLINADO

STIFT MED VINKLAD SIDOELEKTROD

ϕ 14mm × 12.7mm Hex 20.8mm Fig. ⑥(f)	B7HCS B8HCS B9HCS	BR8HCS-10
ϕ 14mm × 19.0mm Hex 20.8mm Fig. ⑦(f)	B7ECS B8ECS B9ECS	BR8ECS BR9ECS BR10ECS
		BR8ECM BR9ECM BR10ECM
ϕ 14mm × 19.0mm Hex 20.8mm Fig. ⑧(f)		



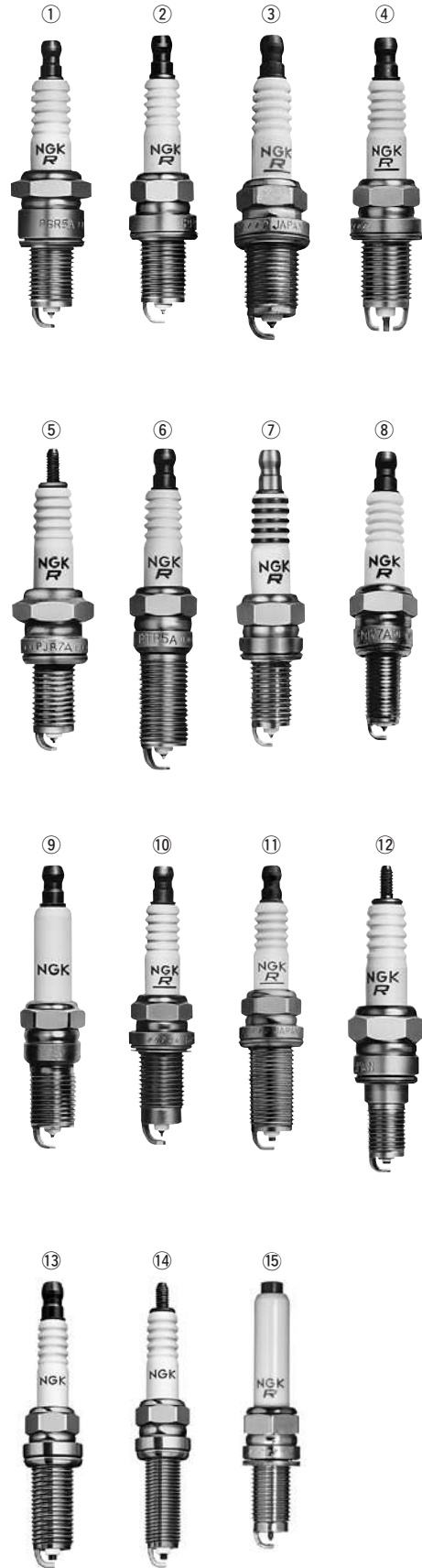

PLATINUM, IRIIDIUM TIPPED TYPES
TYPEN MIT PLATINELEKTRODENSPITZE, IRIIDIUMSPITZE
TYPE[S] À EXTREMITÉ EN PLATINE, IRIIDIUM
TIPOS CON PUNTA DE PLATINO, IRIIDIO
STIFT MED MITTELEKTRODÄNDA AV PLATINA OCH IRIIDIUM

	RESISTOR MIT WIDERSTAND RÉSISTANCE RESISTOR RESISTOR
ϕ 14mm × 19.0mm Hex 20.8mm Fig. ① i	PGR5A,-11 PGR5C-11 BPR5EP-11,-13 PGR6A,-11 PGR6C-11 BPR6EP-8 PGR7A 125CX 126CX IGR7A
ϕ 14mm × 19.0mm Hex 20.8mm Fig. ① h	IGR5C13 GR7CI-8
ϕ 14mm × 19.0mm Hex 16.0mm Fig. ② a	PFR5A-11 PFR5K-11 BCPR5EP-8,-11,-13 PFR6A-11 PFR6H-10 PFR6K-11 BCPR6EP-8,N-8,-11,-N-11,-13 PFR7A-11 PFR7H-10
Fig. ③ h ISO	FR4AP-10,-11 FR4BP-11 FR5AP-10,-11 FR5BP-11 FR5AP-11E FR6AP-10,-11 FR6BP-11 FR7AP-11 115CX 116CX 136CX FR5EI-13 PFR5B-9,-11,-11B PFR5C-11 PFR6B,-9,-11,-11B,-11C PFR6E-10 PFR7B,-9,-11 PFR8B,-9 PFR4G-11 PFR5J-11 PFR5G-11,-13E PFR6H-10 PFR6J,-11 PFR6G,-9,-11,-13,-13E PFR7G,-9,-11 PFR7S11EG PFR5L-11 PFR5N-11,8DS PFR5P-11 PFR6L-11,-13 PFR6N-11 PFR6P-11 PFR6Q PFR7N-D PFR7Q PFR5R-11 BKR5EP-11 BKR6EP-8,-11,-13,-N-8
Fig. ④ c ISO	BKR6EKPA
Fig. ④ d ISO	BKR5EKUP
Fig. ④ e ISO	BKR5EKPB-11,-13 BKR6EKPB-11
Fig. ④ j ISO	BKR5EQUPA BKR6EQUP BKR6EQUPA
Fig. ③ f ISO	PFR6M PFR6X-11 PFR7M PFR7S8EG
Fig. ③ g ISO	PZFR5B PZFR5F,-11 IZFR5B IZFR5F11 IZFR5G IZFR5L11 PZFR6B PZFR6F,-11 IZFR6B IZFR6F11 SIFR6B7G T6728R T6728U-G035
Fig. ③ h ISO	IFR5A11,-8N IFR5D10 IFR5E11 IFR6A11 IFR6C IFR6D10 IFR6E11 IFR6AD7DG IFR6AE11S IFR7F-D IFR7B4D IFR8AF4D IFR8AG8 IFR5G11 IFR5J11 IFR5N10 IFR5T-8N,11 IFR6J11 IFR6S IFR6T11 IFR7X7G
Fig. ③	PZFR6H IZFR6J IZFR6N-E IZFR6Q
Fig. ③ m	PFR6W-TG
Fig. ③ n	DIFR5E11 DF6A-13B DIFR6D11D DIFR6D13 ZFR5LP-13G IZFER7A4D 11G-55
ϕ 14mm × 21.5mm Hex 16.0mm	PZFR6R,8EG
ϕ 14mm × 22.0mm Hex 16.0mm Fig. ⑩ k ISO	PZFR5C PZFR5D-11 IZFR5C IZFR7E-D
ϕ 14mm × 22.5mm Hex 16.0mm	135CX
ϕ 14mm × 25.0mm conical seat Hex 16.0mm Fig. ⑥ h	PTR5A-13 ILTR5D

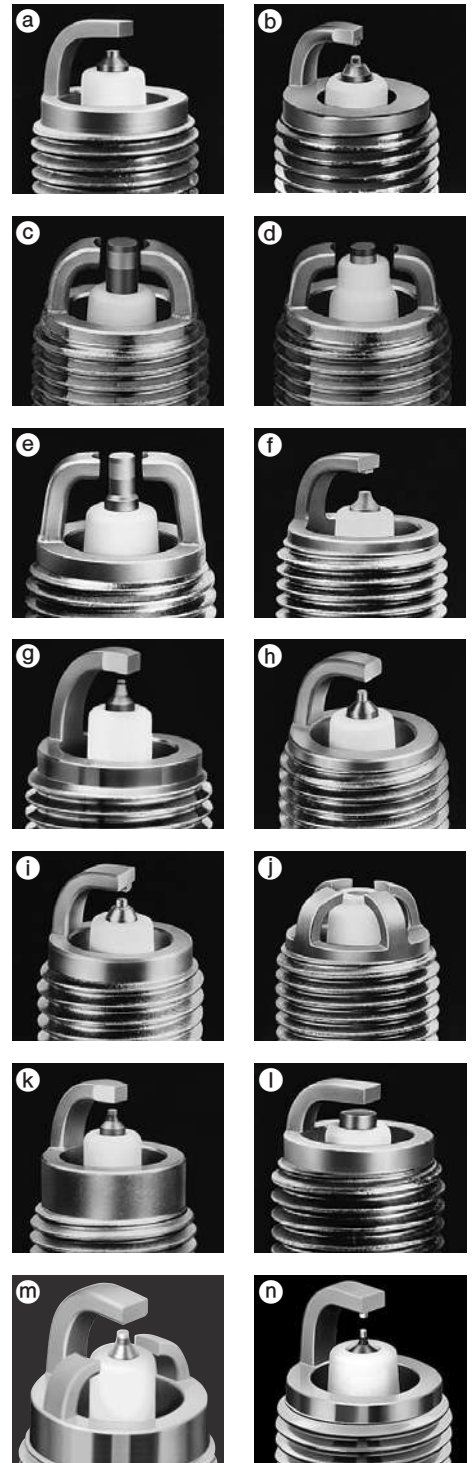

	RESISTOR MIT WIDERSTAND RÉSISTANCE RESISTOR RESISTOR
ϕ 14mm \times 17.5mm conical seat Hex 16.0mm Fig. ⑨①	PTR4B-15 PTR5C-13 ITR4A15 ITR6F13
ϕ 14mm \times 17.5mm conical seat Hex 16.0mm Fig. ③④⑧ Fig. ⑨⑨	ITR5H13 PTR5D-10,-13 TR5AI-13 TR5AP-13 ITR6G9 PTR6D-13,-13G ITR7J9D PZTR5A-15
ϕ 14mm \times 20.5mm Hex 16.0mm Fig. ③⑫	IZFR6K11,11E,13 IZFR6K-11S,IZFR6K11NS PZFR7G-G
ϕ 14mm \times 21.5mm Hex 16.0mm Fig. ⑭	PZFR5N-11T
ϕ 14mm \times 22.0mm Hex 16.0mm Fig.	PZFR6J-11
ϕ 14mm \times 26.5mm Hex 16.0mm Fig. ⑩	PLFR4A-11 PLFR5A-9,-11 ILFR5T11 ILFR5B11 DILFR5A11 DILFR5C11 DILFR5E11 DF5B-8A DILFR5L11 ILZFR5E8D LZFR5CI-11 PLFR6A-9,-11 ILFR6T11 ILFR6K8 ILFR6G,-E SILFR6A11 DILFR6D11D DILFR6L11 PLFR7A-9 DILFR7K9G ILFER7A8EG SILZFR7A9G PLZFR6A-11S ILZFR6A11 DILFR7B10G 155CX 156CX
ϕ 14mm \times 28.0mm Hex 16.0mm Fig. ⑩	LZFR5BI-11 LZFR5DI-11 LZFR6AI
ϕ 14mm \times 29.5mm Hex 16.0mm Fig. ⑩①	LZFR5AQP
ϕ 14mm \times 25.0mm conical seat Hex 16.0mm	PLZTR4A-13 PLZTR5A-13 ILTR5A-13G ILTR5P11D LTR5BI-13 LTR6AP-11 LTR6A-8G,-13G ILTR6J13 ILTR6M9G LTR6AI-8 LTR6BI-13 LTR6DI-8 LTR6DP13 ILTR7E9D ILTR7J8 ILTR7N8 ILTR7Q9 LTR7CP13
ϕ 12mm \times 19.0mm Hex 18.0mm Fig. ⑤⑧	PJR6A PJR7A IJR7A9 PJR8A
ϕ 12mm \times 19.0mm Hex 16.0mm	IKR6G8 IKR7H8 IZKR8C10D SIKR8B7G IKR9H8 IKR9J8 147CX
ϕ 12mm \times 19.0mm Hex 16.0mm Fig. ⑦①	PKR7A PKR9B KR7AI KR8AI KR9CI IKR6G11 IKR9F8
ϕ 12mm \times 19.0mm Hex 16.0mm Fig. ⑦②	DCPR8EKP
ϕ 12mm \times 20.5mm Hex 16.0mm	IKER7A8EGS ZKR7BI-10 PKER7A8EGS PKER7A8DES
ϕ 12mm \times 21.5mm Hex 16.0mm Fig. ⑮⑧	PZKER7B8EGS
ϕ 12mm \times 22.0mm Hex 16.0mm	IZKR7A
ϕ 12mm \times 26.5mm Hex 16.0mm	ILKR6F11 ILZKR6F11 SILKR6C10E SILKR6D10G ILKR7D8 ILKR7J8 ILKR7K8 ILKR7L8G ILZKR7D8 ILZKR7E10DG LKR7FI-8 SILKR7C8DE SILZKR7E11 SILZKR7E8EG SILZKR7E9 SILZKR7E9G SILZKR7G8DE ILKR8M5D ILKR8P8 SILZKR8E8D SILZKR8E8G ILKR9G8 ILKR9H8 HKS-G40XL
Fig. ⑩	DILKR7E11
Fig.	
ϕ 12mm \times 28.0mm Hex 16.0mm	DILZKR7B11G ILZKR7G7G
ϕ 12mm \times 29.0mm Hex 16.0mm	SILZKKER8A8E
ϕ 12mm \times 25.0mm Hex 14.0mm	SILZNR6D9 SILNAR7B7 SILNAR7C7DG ILNAR8B7G ILZNR8B7G SILNAR8A7
ϕ 12mm \times 26.5mm Hex 14.0mm	ILKAR7L11 ILKAR7L11D ILKAR7M10 ILZKAR7D11 LKAR7CI-8 ILKAR8H6 LKAR8CI-8 SILKAR8C6DG SILKAR8C6DS SILKAR8D6 SILKAR8E4DG SILKAR8F8 SILZKAR8D4D SILZKFR8B7S SILZNR8C7H HKS-M50HL
Fig. ⑬④	LKAR8AP7JD LKAR8AP7JDS
Fig. ⑬⑤	DILKAR7B8 DILKAR7G11DS DILKAR7H11GS DILKAR7M8 DILZKAR7B11 DILKAR8J9G DILKAR8K8D DILKAR8L8D
Fig. ⑬	



	RESISTOR MIT WIDERSTAND RÉSISTANCE RESISTOR RESISTOR
ϕ 12mm \times 27.0mm Hex 14.0mm	SILZKFR8C7S SILZKFR8D7S
ϕ 12mm \times 27.5mm Hex 14.0mm	SILZKFR8E7S
ϕ 12mm \times 28.0mm Hex 14.0mm Fig. (K)	DILZKAR7C11S ILZKAR7E11S ILZKAR8F8S ILZKAR8G8 ILZKAR8H8S ILZKAR8J8SY ILZKAR8A7G SILZKAR8F7S
ϕ 12mm \times 28.5mm Hex 14.0mm Fig. (N)	DILKA7E9HS
ϕ 10mm \times 19.0mm Hex 16.0mm Fig. (8) ①	CR9EBI-9
	Fig. (8) MR8CI-8 SIMR7B9DS
	Fig. (8) (C) MR8BI-8
ϕ 10mm \times 19.0mm Hex 16.0mm Fig. (12)	
ϕ 10mm \times 22.0mm Hex 16.0mm	MR8BP8HJS
ϕ 10mm \times 26.5mm Hex 14.0mm Fig. (14)	ILMAR7B8 LMAR7CI-8 SILMAR7D9DS ILMAR8C9D LMAR8AI-8E LMAR8BI-9 SILMAR8C9 SILMFR8A8G SILMAR9B9
ϕ 10mm \times 26.5mm Hex 14.0mm Fig. (d)	LMAR9AP8JS
ϕ 12mm \times 26.5mm Bi-Hex 14.0mm	ILZKBR7B8DG PLZKBR7B8DG SILZKBR8B8HG SILKGR9A7EG
ϕ 12mm \times 27.5mm Bi-Hex 14.0mm	SILZKBR8D8S SILZKBR8E8S SILZKGR8A8S SILZKGR8B8S
ϕ 12mm \times 28.0mm Bi-Hex 14.0mm	SILZKG8D7E
ϕ 12mm \times 28.5mm Bi-Hex 14.0mm	SILZKBR8F8S SILZKGR8C8S

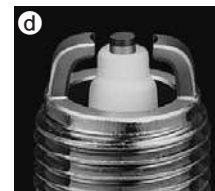

COMPACT TYPES

KOMPAKT STIFT
TIPOS COMPACTOS

TYPES COMPACTES
KOMPACTE TYPEN

	NON-RESISTOR NON-RÉSISTANCE ICKERESISTOR	OHNE WIDERSTAND NO-RESISTOR	RESISTOR RÉSISTANCE RESISTOR	MIT WIDERSTAND RESISTOR
ϕ 18mm \times 16mm Hex 25.4mm	R8160B-10			
ϕ 14mm \times 9.5mm Hex 19.0mm Fig. ①a	BM4A	B2-LM * B4-LM *	BMR2A,-10 BMR4A BMR6A BMR7A	BR2-LM * BR4-LM * * Hex.20.8mm
	BM6A BM7A	BM6 * BM7 * * Hex.20.8mm	BPM4A BPM6A,-10 BPM7A	BPMR4A,-10 BPMR6A,-10 BPMR7A,-9
ϕ 14mm \times 12.7mm Hex 20.8mm Fig. ②a	BL-6H			
ϕ 14mm \times 7.8mm Conical seat Hex 16.0mm Fig. ③a	BM6F BM7F	BM6FY	BMR6F	
	BPM6F BPM7F		BPMR6F	
ϕ 10mm \times 8.6mm Hex 14.0mm Fig. ④a	CM-6			
ϕ 10mm \times 9.5mm Hex 16.0mm Fig. ⑧a			CMR6A CMR7A	
ϕ 10mm \times 12.7mm Hex 16.0mm Fig. ⑧e			CMR5H CMR6H CMR7H	
ϕ 14mm \times 9.5mm Hex 19.0mm Fig. ①c	BPM6Y BPM7Y BPM8Y		BPMR6Y BPMR7Y BPMR8Y	



FARM EQUIPMENT TYPES

LANDMASCHINEN TYPEN
TIPOS MÁQUINAS AGRÍCOLAS

TYPES MACHINES AGRICOLES
FOR JORDBRUKS-MASKINER

PF1/2" \times 22.5mm Hex 23.8mm Fig. ⑤d	G-27 G-2Z
---	----------------------------

SURFACE DISCHARGE TYPES

GLEITFUNKENTYPEN

TYPE À DÉCHARGE SUPERFICIELLE

TIPO DESCARGA EN SUPERFICIE TÅNDSTIFT MED YTGNIISTGAP

ϕ 14mm \times 12.7mm Hex 20.8mm Fig. ⑥f	BUHX(Series gap) BUHXW-1(Series gap)	
	BUH	
	BUHW BUHW-2	BUZHW BUZHW-2
ϕ 14mm \times 19.0mm Hex 20.8mm Fig. ⑦f	BUE	

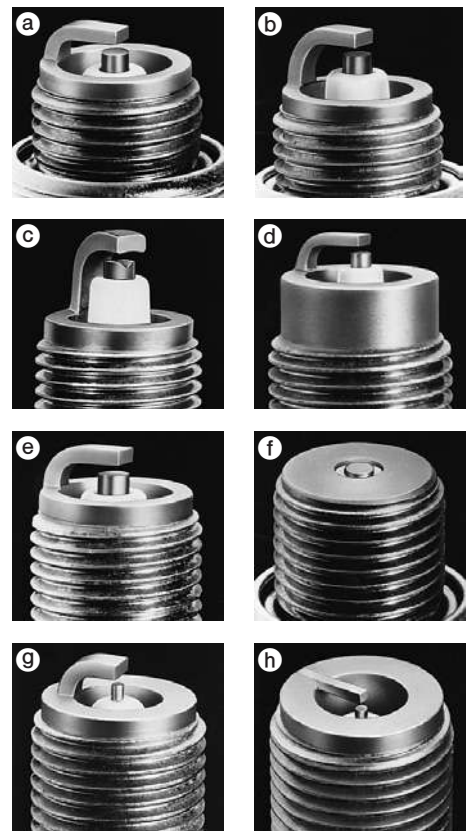

RACING TYPES

RENN-TYPEN

TYPES COURS

TIPOS DE CARRERAS RACERSTIFT

	Nickel electrode Nickel Elektrode Electrodo de nickel Electrodo de níquel Nickel elektrod	Precious metal electrode Elektrode mit sonde-redel metall Electrode en metal precieux Electrodo de metal precioso Ädelmetall elektrod	Platinum electrode Platinel Ektrode Electrodo de platino Electrodo de platino Platina elektrod
ϕ 14mm \times 19.0mm Hex 20.8mm	(Fig. ⑨g) B8EGV BR8EG* B9EGV BR9EG* B10EGP BR10EG* B11EG	(Fig. ⑨g) B8EGV B85EGV B9EGV B95EGV B10EGV B105EGV B11EGV	(Fig. ⑨h) B10EGP

*Resistor Type



IX TYPES

IX TYPEN TYPES IX
TIPOS IX IX-STIFT

	RESISTOR RÉSISTANCE RESISTOR	MIT WIDERSTAND RESISTOR	
ϕ 18mm × 10.9mm Hex 20.8mm Fig. ① a	WR5IX		
ϕ 14mm × 19.0mm Hex 20.8mm Fig. ② b	GR4IX GR5IX		
	Fig. ② c	BR7EIX BR8EIX BR9EIX BR10EIX	
	Fig. ② d	BR8ECSIX BR9ECSIX,-5	
	Fig. ③ d	BR8ECMIX BR9ECMIX BR10ECMIX	
ϕ 14mm × 12.7mm Hex 20.8mm Fig. ④ b	BPR6HIX BPR7HIX BPR8HIX		
	Fig. ④ c	BR6HIX BR7HIX BR8HIX BR9HIX BR10HIX	
ϕ 14mm × 9.5mm Hex 20.8mm Fig. ⑤ a	XR4IX XR5IX XR45IX		
ϕ 14mm × 19.0mm Hex 16.0mm Fig. ⑥ b	BCPR7EDIX		
	Fig. ⑦ b	BCPR5EIX,-11 BCPR6EIX,-11 BCPR7EIX,-11	
	Fig. ⑧ b	BKR4EIX BKR5EIX,-11 BKR6EIX,-11 BKR7EIX,-11 BKR8EIX BKR9EIX	
Fig. ⑧ e	ZFR5FIX-11 ZFR6FIX-11		
ϕ 14mm × 26.5mm Hex 16.0mm Fig. ⑨ b	LFR5AIX-11 LFR6AIX-11 LFR7AIX	LKR6AIX LKR7AIX	LKR6AIX-P LKR6CIX
ϕ 14mm × 17.5mm Conical seat Hex 16.0mm Fig. ⑩ b	BPR6EFIX-10,-15		
	Fig. ⑩ a	TR4IX TR5IX TR6IX TR7IX TR8IX	TR55IX TR65IX TR75IX TR85IX
ϕ 14mm × 20.5mm Conical seat Hex 16.0mm Fig. ⑪ e	TR5-1IX	TR45-1IX TR55-1IX	
ϕ 14mm × 11.2mm Conical seat Hex 16.0mm Fig. ⑫ c	YR5IX YR55IX		
	Fig. ⑫ c	BR6FIX	
Fig. ⑫ a	UR4IX UR5IX UR6IX	UR45IX UR55IX	
	UR6IX		
ϕ 14mm × 25.0mm Conical seat Hex 16.0mm Fig. ⑬ b	LTR5IX-11 LTR6IX-11 LTR7IX-11		
	Fig. ⑬ e	LZTR4AIX-11 LZTR5AIX-13 LZTR6AIX-13 LZTR7AIX-13	

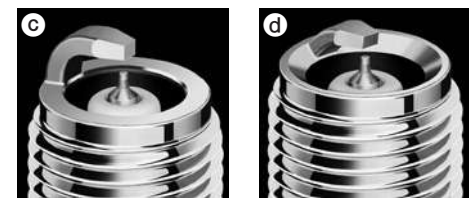
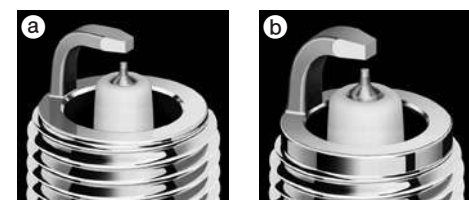

IX TYPES

IX TYPEN TYPES IX
TIPOS IX IX-STIFT

	RESISTOR MIT WIDERSTAND RÉSISTANCE RESISTOR RESISTOR
ϕ 12mm × 19.0mm Hex 16.0mm Fig. ① a	DCPR6EIX DCPR7EIX DCPR8EIX DCPR9EIX
Fig. ① b	DCR7EIX DCR8EIX DCR9EIX
ϕ 12mm × 19.0mm Hex 18.0mm Fig. ② a	DPR7EIX-9 DPR8EIX-9 DPR9EIX-9
Fig. ② b	DR7EIX DR8EIX DR9EIX
ϕ 12mm × 21.0mm Hex 18.0mm Fig. ③ a	DPR8ZIX
ϕ 12mm × 26.5mm Conical seat Hex 14.0mm Fig. ④ d	ZNAR7AIX ZNAR6AIX-11
ϕ 12mm × 26.5mm Hex 14.0mm	LZKR6AIX
ϕ 10mm × 19.0mm Hex 16.0mm Fig. ⑤ a	CPR6EAIX-9S CPR7EAIX-9 CPR9EAIX-9
Fig. ⑤ c	CR7EIX CR8EIX CR9EIX CR10EIX
Fig. ⑥ b	CR8EHIX-9 CR9EHIX-9
ϕ 10mm × 12.7mm Hex 16.0mm Fig. ⑦ b	CR5HIX CR6HIX CR7HIX CR8HIX CR9HIX
ϕ 8mm × 19.0mm Hex 13.0mm Fig. ⑧ e	ER8EHIX ER9EHIX

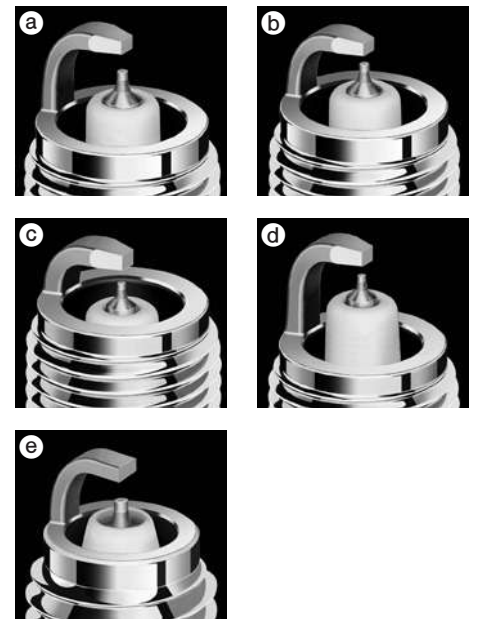



SERIES



IGNITION
PARTS

Series of NGK GLOW PLUGS

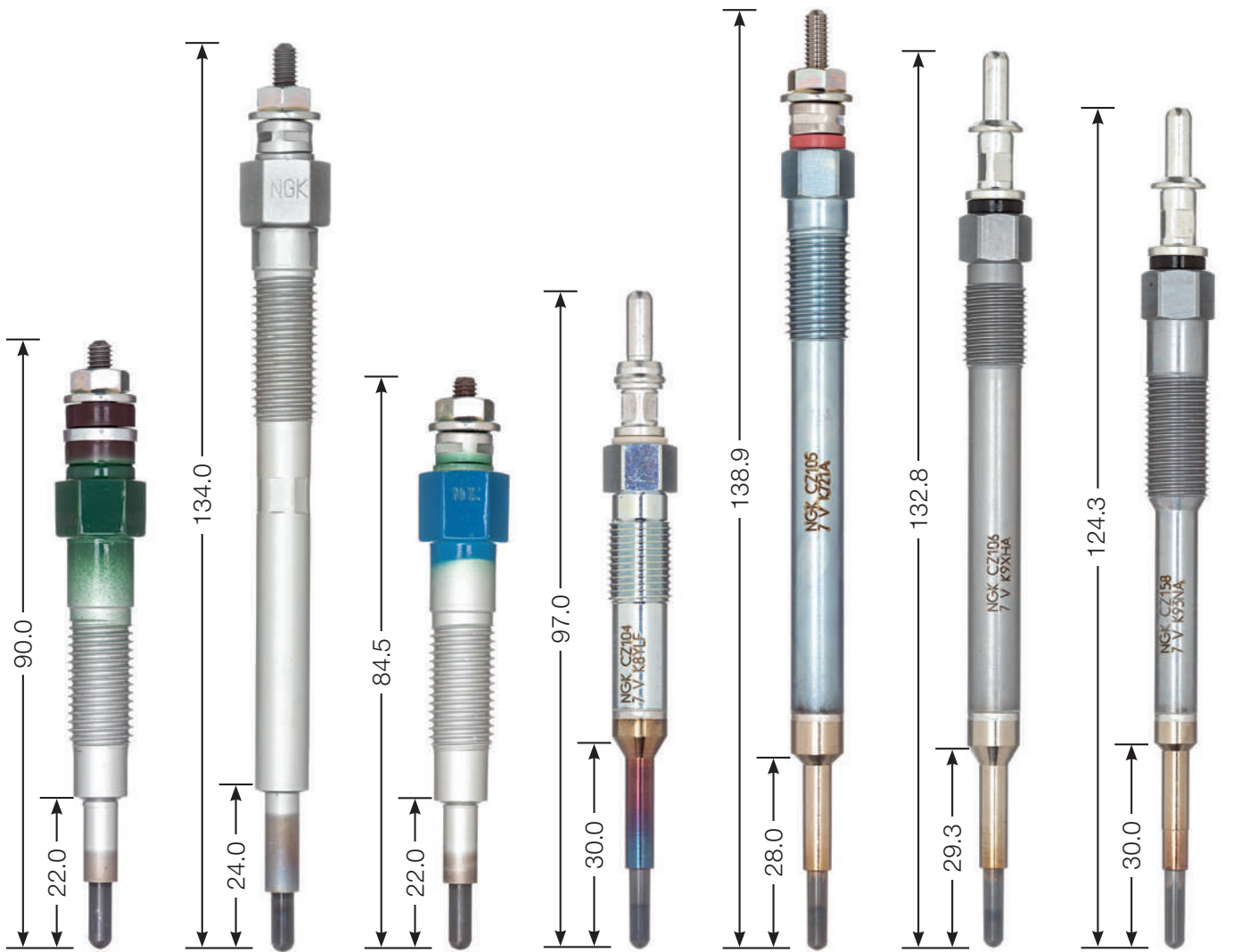

CX 51
M 10 x 1.25
12 Hex
6.5 V

CZ 24
M 10 x 1.25
12 Hex
11 V

CZ 51
M 10 x 1.25
12 Hex
6.5 V

CZ 104
M 10 x 1.0
10 Hex
7 V

CZ 105
M 10 x 1.25
10 Hex
7 V

CZ 106
M 10 x 1.0
10 Hex
7 V

CZ 158
M 10 x 1.0
10 Hex
7 V

DP 52
140

DP 53



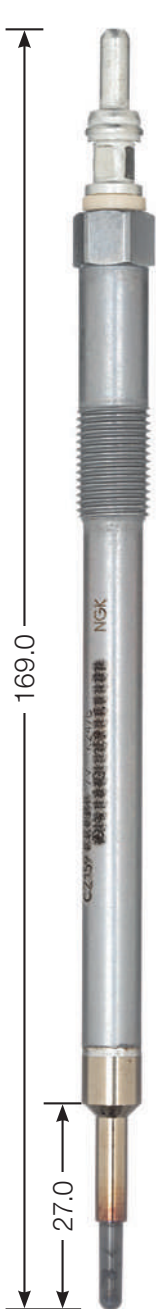

CZ 159
M 10 x 1.0
10 Hex
7 V
DP 84



CZ 163
M 10 x 1.25
12 Hex
7 V
DP 82



CZ 165
M 10 x 1.25
10 Hex
7 V
DP 87



CZ 167
M 10 x 1.0
10 Hex
7 V
DP 91
141



CZ 203
M 10 x 1.25
12 Hex
11 V
DP 68



CZ 251
M 10 x 1.25
12 Hex
11 V
DP 76

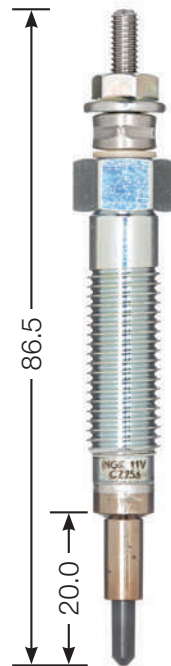

CZ 256
M 10 x 1.25
12 Hex
11 V

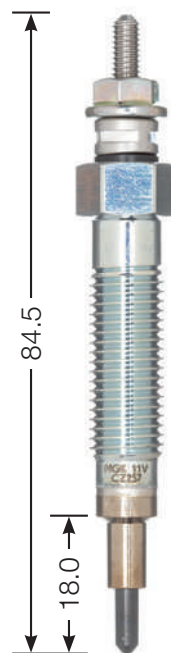

CZ 257
M 10 x 1.25
12 Hex
11 V
DP 83



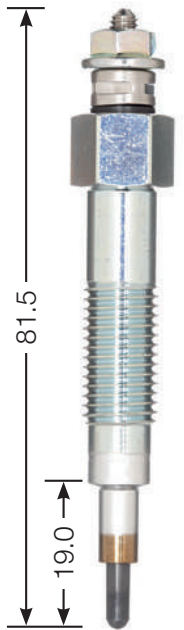

CZ 259
M 10 x 1.25
12 Hex
11 V

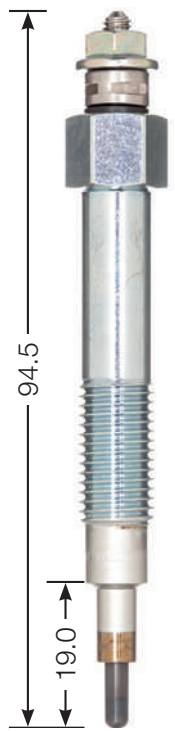

CZ 260
M 10 x 1.25
12 Hex
11 V



CZ 258
M 10 x 1.25
12 Hex
11 V



CZ 267
M 10 x 1.25
10 Hex
11 V
DP 90
142



CZ 271
M 10 x 1.25
10 Hex
11 V



CZ 274
M 10 x 1.25
12 Hex
11 V



CZ 303
M 8 x 1.0
8 Hex
7 V
DP 54

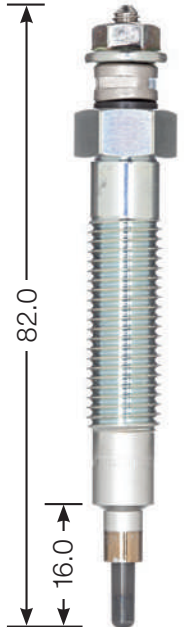

CZ 261
M 10 x 1.25
12 Hex
11 V



CZ 262
M 10 x 1.25
12 Hex
11 V
DP 13



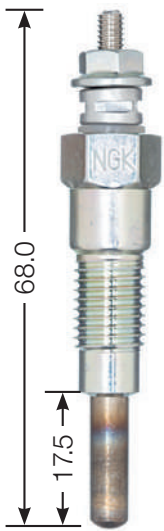

Y-103
M 10 x 1.25
12 Hex
10.5 V

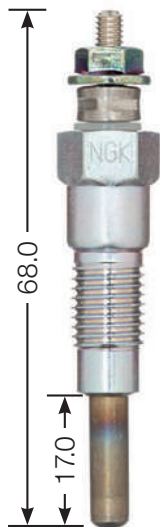

Y-103-1
M 10 x 1.25
12 Hex
9 V



Y-103-2
M 10 x 1.25
12 Hex
9.5 V

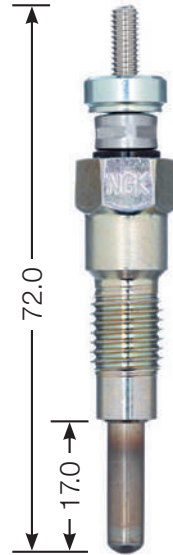

Y-103 K
M 10 x 1.25
12 Hex
10.5 V



Y-103 V
M 10 x 1.25
12 Hex
10.5 V

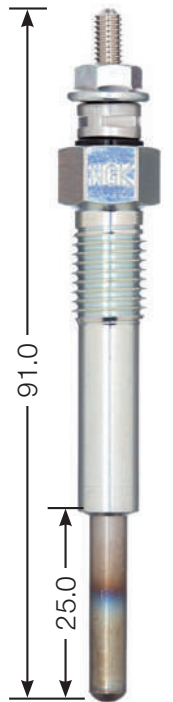

Y-104
M 10 x 1.25
12 Hex
10.5 V

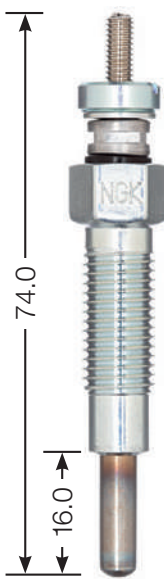

Y-106-1
M 10 x 1.25
12 Hex
10.5 V



CZ 304
M 8 x 1.0
8 Hex
7 V
DP 55



CZ 551
M 10 x 1.0
8 Hex
7 V
DP 85



Y-106 V
M 10 x 1.25
12 Hex
10.5 V

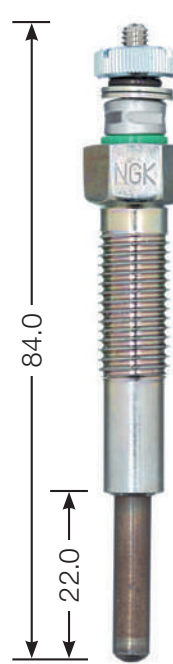

Y-107-1
M 10 x 1.25
12 Hex
10.5 V

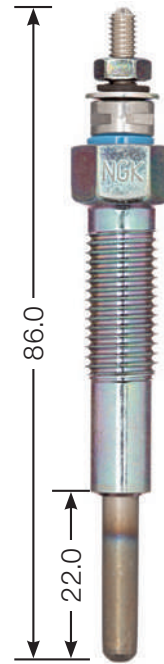

Y-107 R
M 10 x 1.25
12 Hex
10.5 V

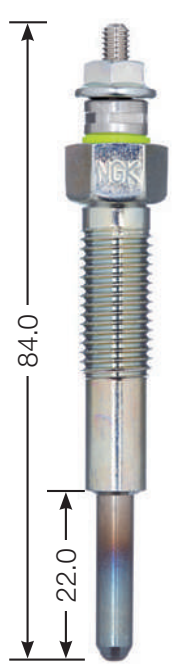

Y-107 V
M 10 x 1.25
12 Hex
10.5 V



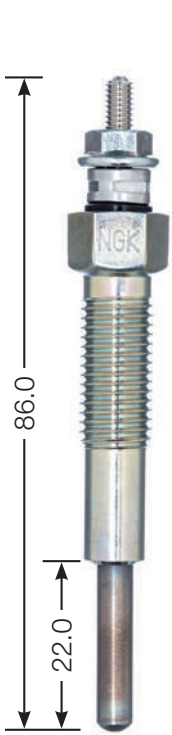

Y-107 T

M 10 x 1.25
12 Hex
8.5 V

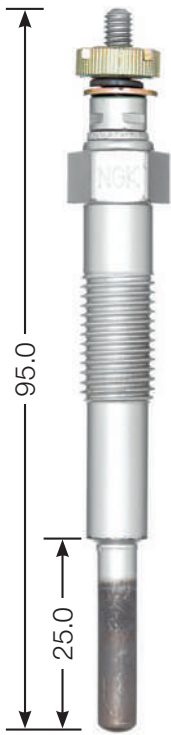

Y-108

M 10 x 1.25
12 Hex
8 V

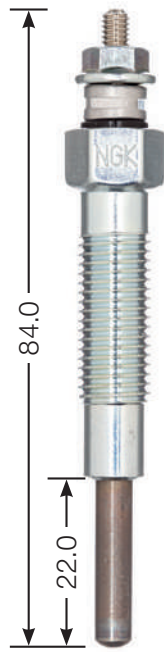

Y-110

M 10 x 1.25
12 Hex
10.5 V



Y-110 V

M 10 x 1.25
12 Hex
10.5 V



Y-112 M1

M 10 x 1.25
12 Hex
11 V

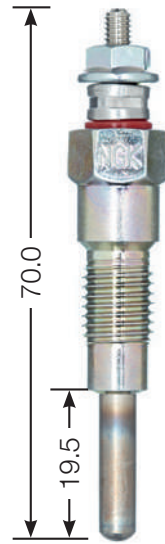

Y-112 R1

M 10 x 1.25
12 Hex
10.5 V

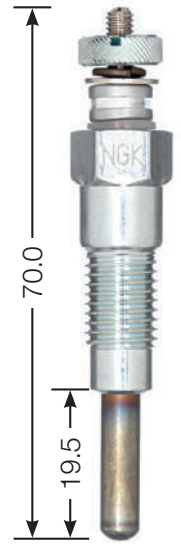

Y-112 T

M 10 x 1.25
12 Hex
11 V

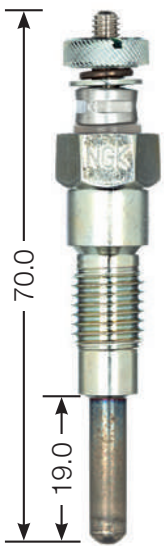

Y-112 TS

M 10 x 1.25
12 Hex
11 V

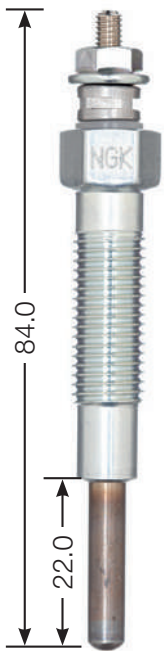

Y-114 T

M 10 x 1.25
12 Hex
10.5 V

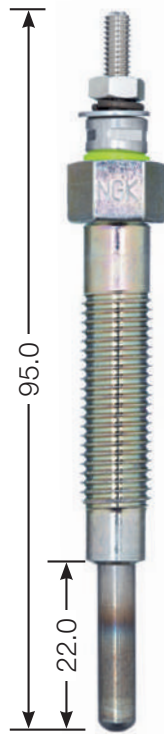

Y-115 R1

M 10 x 1.25
12 Hex
6 V

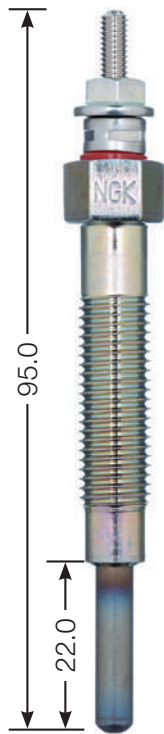

Y-115 T1

M 10 x 1.25
12 Hex
12 V

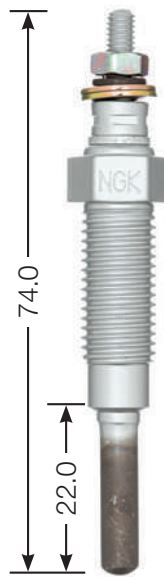

Y-116 V

M 10 x 1.25
12 Hex
10.5 V

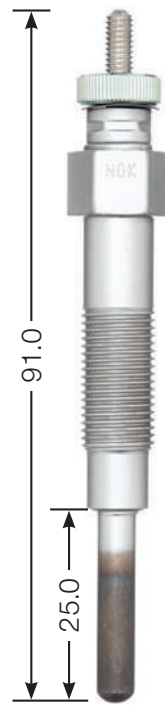

Y-117 RS

M 10 x 1
12 Hex
6.5 V

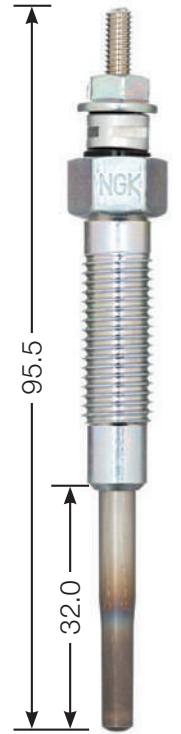

Y-118 R

M 10 x 1.25
12 Hex
7 V



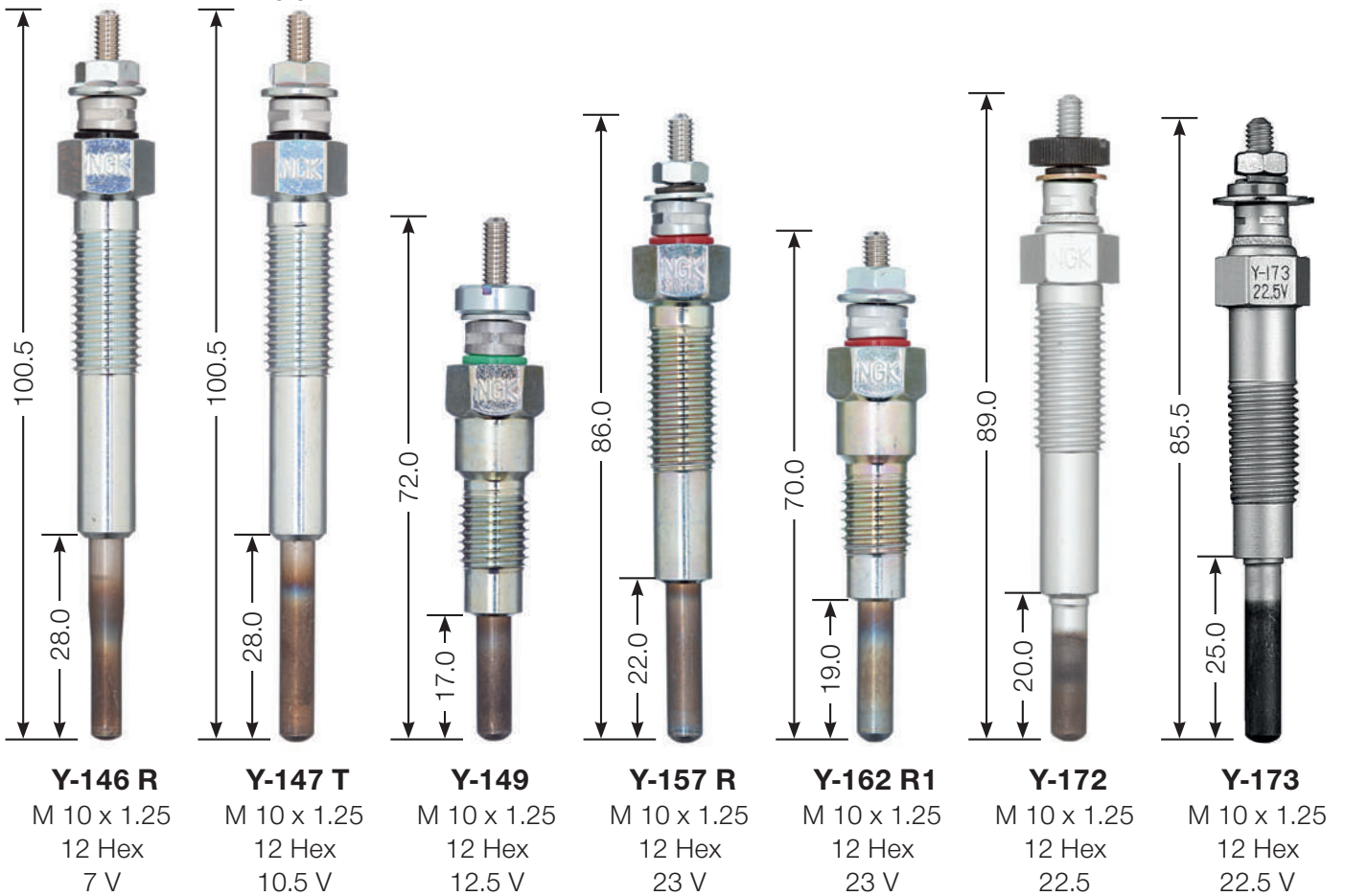
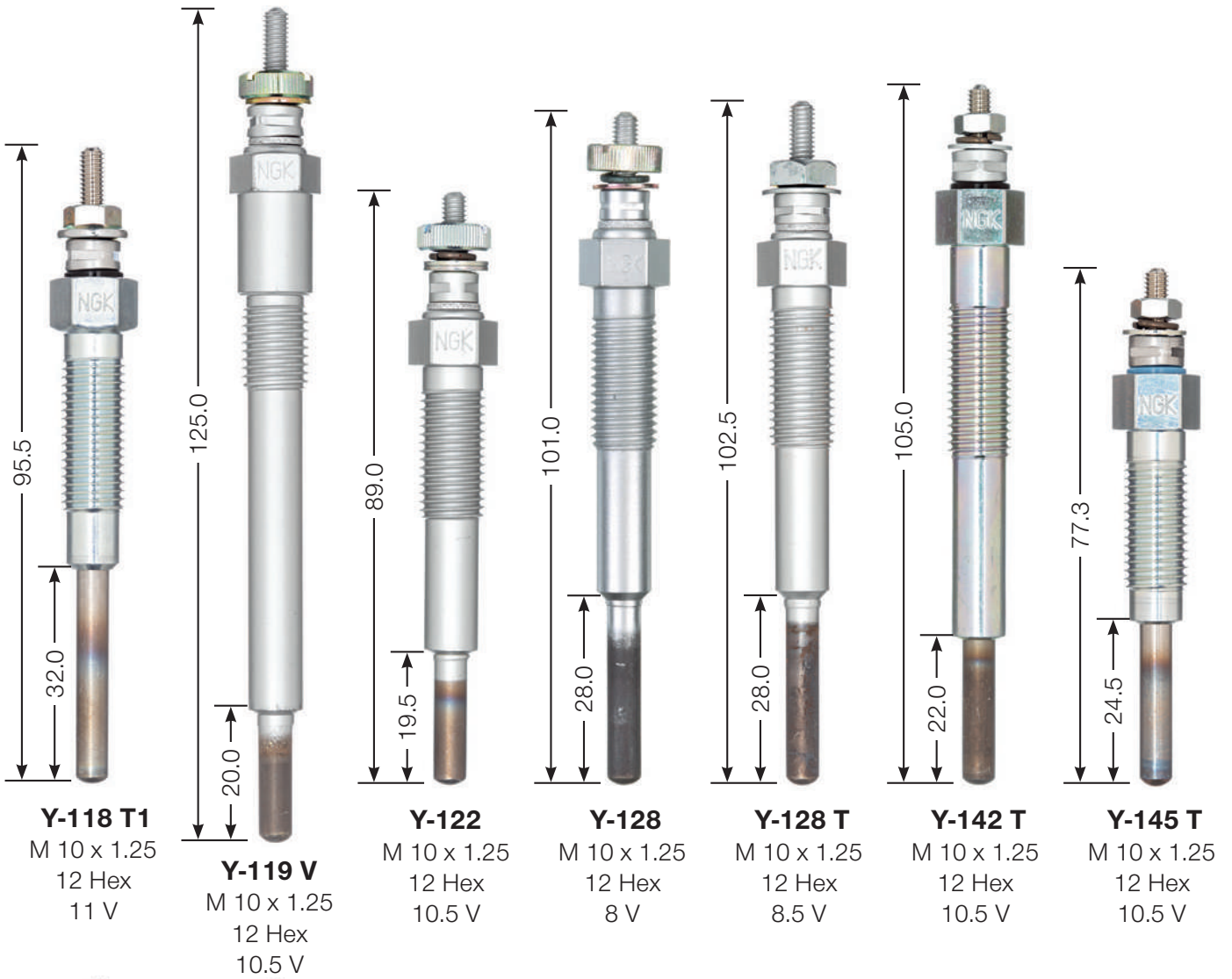



Y-175-2
M 10 x 1.25
12 Hex
22.5 V

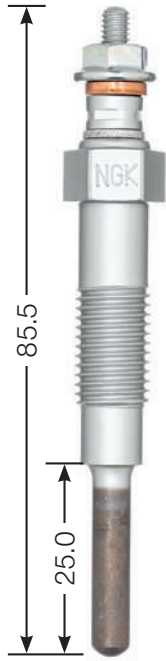

Y-176
M 10 x 1.25
12 Hex
19 V

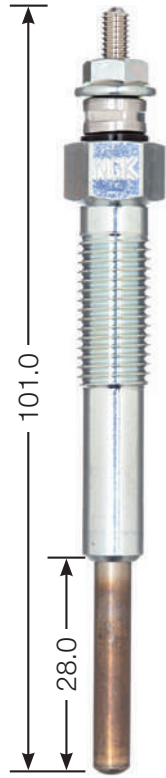

Y-178
M 10 x 1.25
12 Hex
19 V

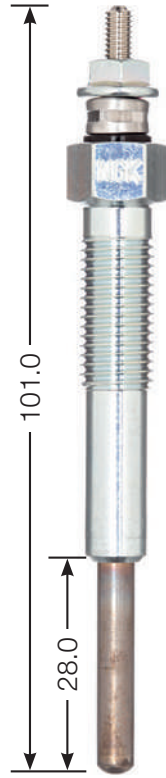

Y-178 T
M 10 x 1.25
12 Hex
20.5 V

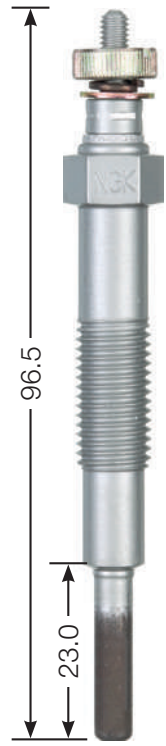

Y-180
M 10 x 1.25
12 Hex
21 V

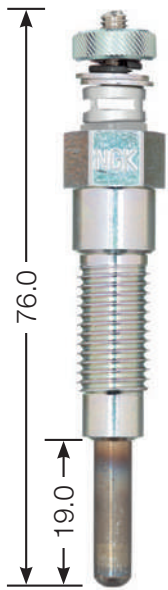

Y-181 T
M 10 x 1.25
12 Hex
23 V

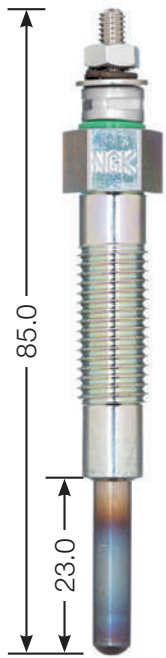

Y-182 T
M 10 x 1.25
12 Hex
22 V

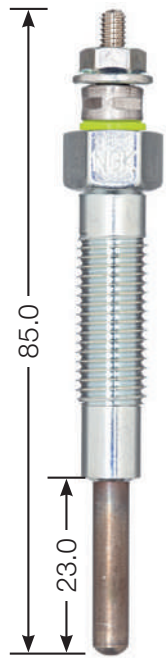

Y-182 T1
M 10 x 1.25
12 Hex
22 V

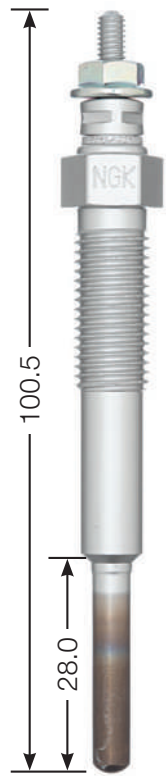

Y-197 R
M 10 x 1.25
12 Hex
14 V

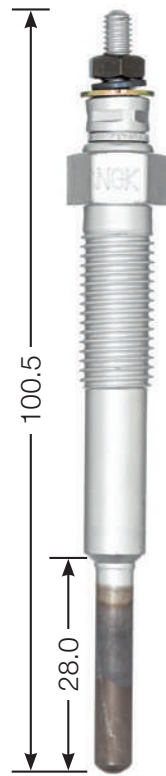

Y-197 T
M 10 x 1.25
12 Hex
23 V

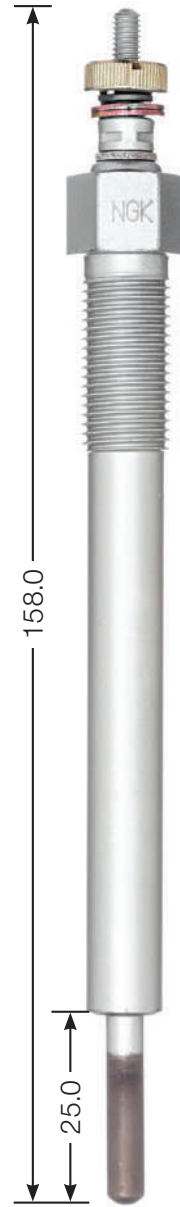

Y-203
M 12 x 1.25
14 Hex
10.5 V



Y-203 V
M 12 x 1.25
14 Hex
10.5 V

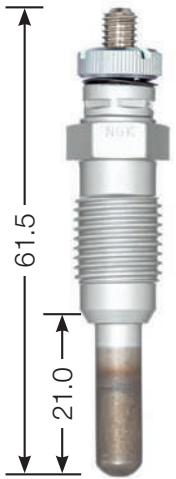

Y-204 RS
M 12 x 1.25
12 Hex
6.5 V

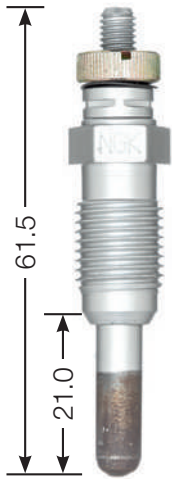

Y-204 TS1
M 12 x 1.25
12 Hex
11 V

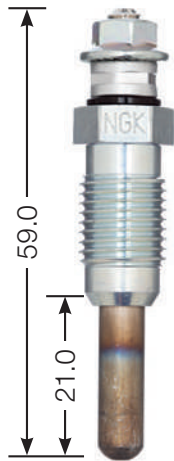

Y-207 T
M 12 x 1.25
12 Hex
11 V



Y-208 T
M 12 x 1.25
12 Hex
11 V



Y-222 T
M 12 x 1.25
14 Hex
11 V



Y-271-2
M 12 x 1.25
12 Hex
20.5 V



Y-272 R1
M 12 x 1.25
14 Hex
23 V



Y-274
M 12 x 1.25
12 Hex
20.5 V



Y-306 R
M 10 x 1.25
12 Hex
5 V

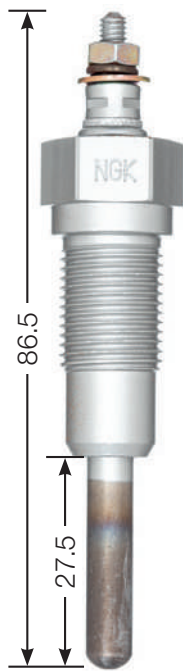

Y-401-3
M 14 x 1.25
17 Hex
10.5 V

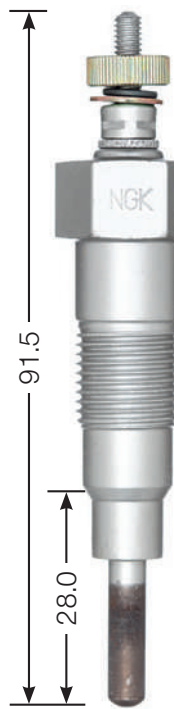

Y-402-2
M 14 x 1.25
17 Hex
8 V

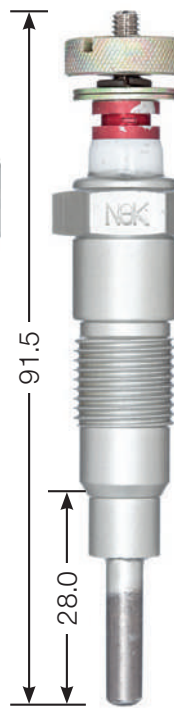

Y-452-1
M 14 x 1.25
17 Hex
19 V





Y-501-U
M 10 x 1.0
10 Hex
11 V
DP 31



Y-502 R
M 10 x 1.0
10 Hex
11 V



Y-503 J
M 10 x 1.0
10 Hex
11 V
DP 10

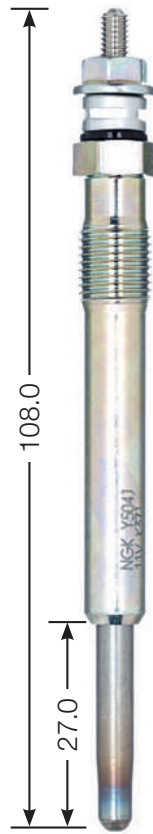

Y-504 J
M 10 x 1.0
10 Hex
11 V
DP 24

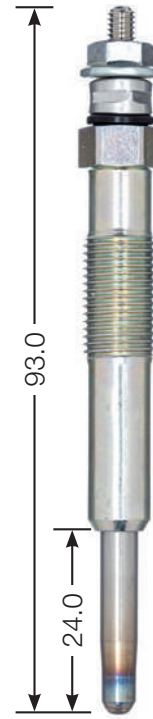

Y-506 J
M 10 x 1.0
10 Hex
11 V
DP 7



Y-507 J
M 10 x 1.0
10 Hex
11 V
DP 32



Y-508 J
M 10 x 1.25
12 Hex
11 V



Y-516 J
M 10 x 1.0
10 Hex
11 V
DP 12



Y-517 J
M 10 x 1.0
10 Hex
11 V





Y-519 J
 M 10 x 1.25
 12 Hex
 11 V
DP 61

Y-522 J
 M 10 x 1.25
 12 Hex
 11 V

Y-523 J
 M 10 x 1.0
 10 Hex
 11 V
DP 37

Y-524 J
 M 10 x 1.0
 10 Hex
 10 V
DP 27
 149

Y-526 J1
 M 10 x 1.25
 12 Hex
 11 V
DP 69

Y-527 J
 M 10 x 1.25
 12 Hex
 11 V
DP 67

Y-529 J
 M 10 x 1.25
 12 Hex
 11 V



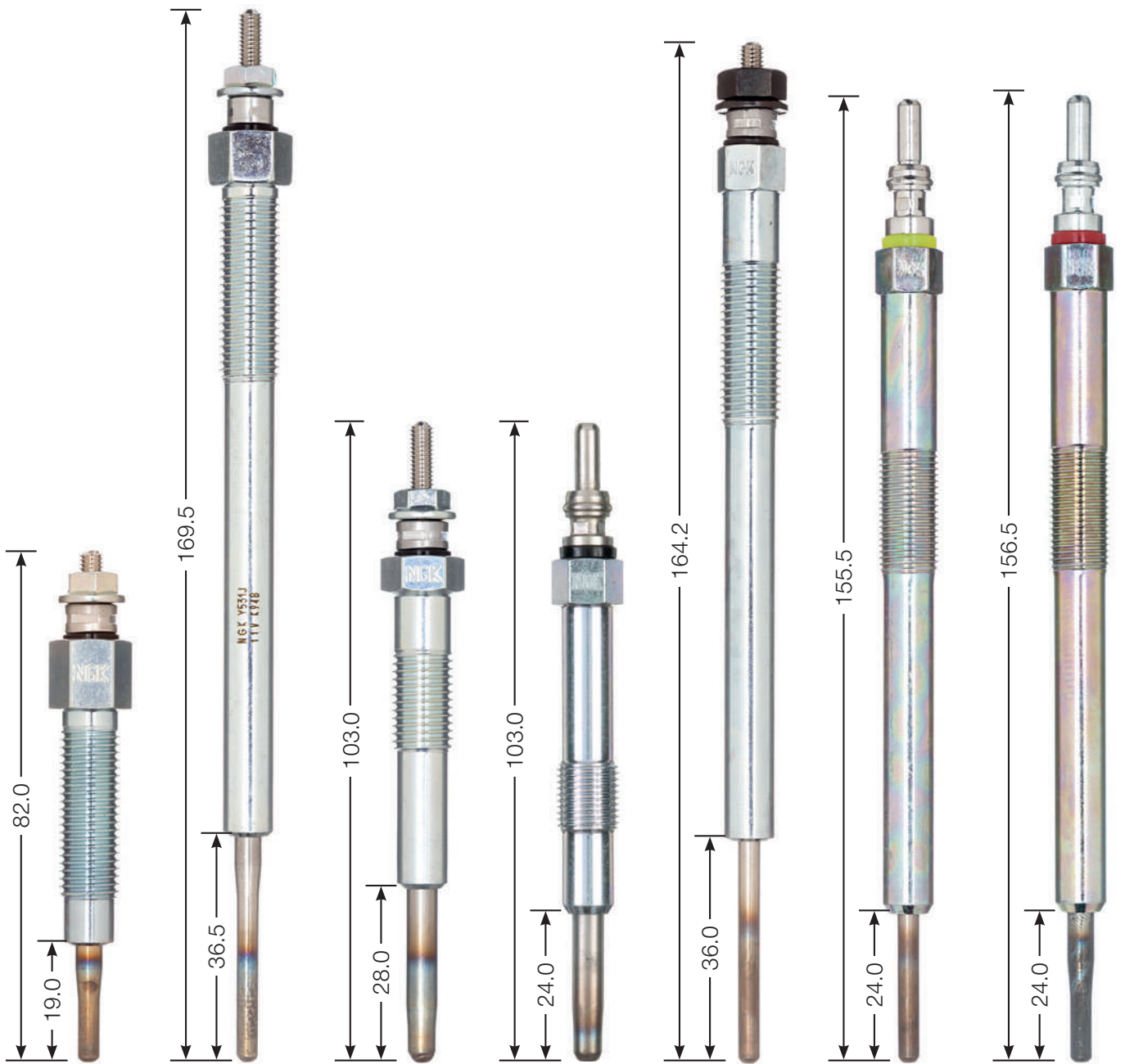

Y-530 J
 M 10 x 1.25
 12 Hex
 11 V

Y-531 J
 M 10 x 1.25
 12 Hex
 11 V
DP 44

Y-532 J
 M 10 x 1.25
 12 Hex
 11 V

Y-534 J
 M 10 x 1.0
 10 Hex
 11 V
DP 36
 150

Y-535 J
 M 10 x 1.25
 10 Hex
 11 V

Y-536 J
 M 10 x 1.0
 10 Hex
 11 V
DP 81

Y-537 AS
 M 10 x 1.0
 10 Hex
 5 V

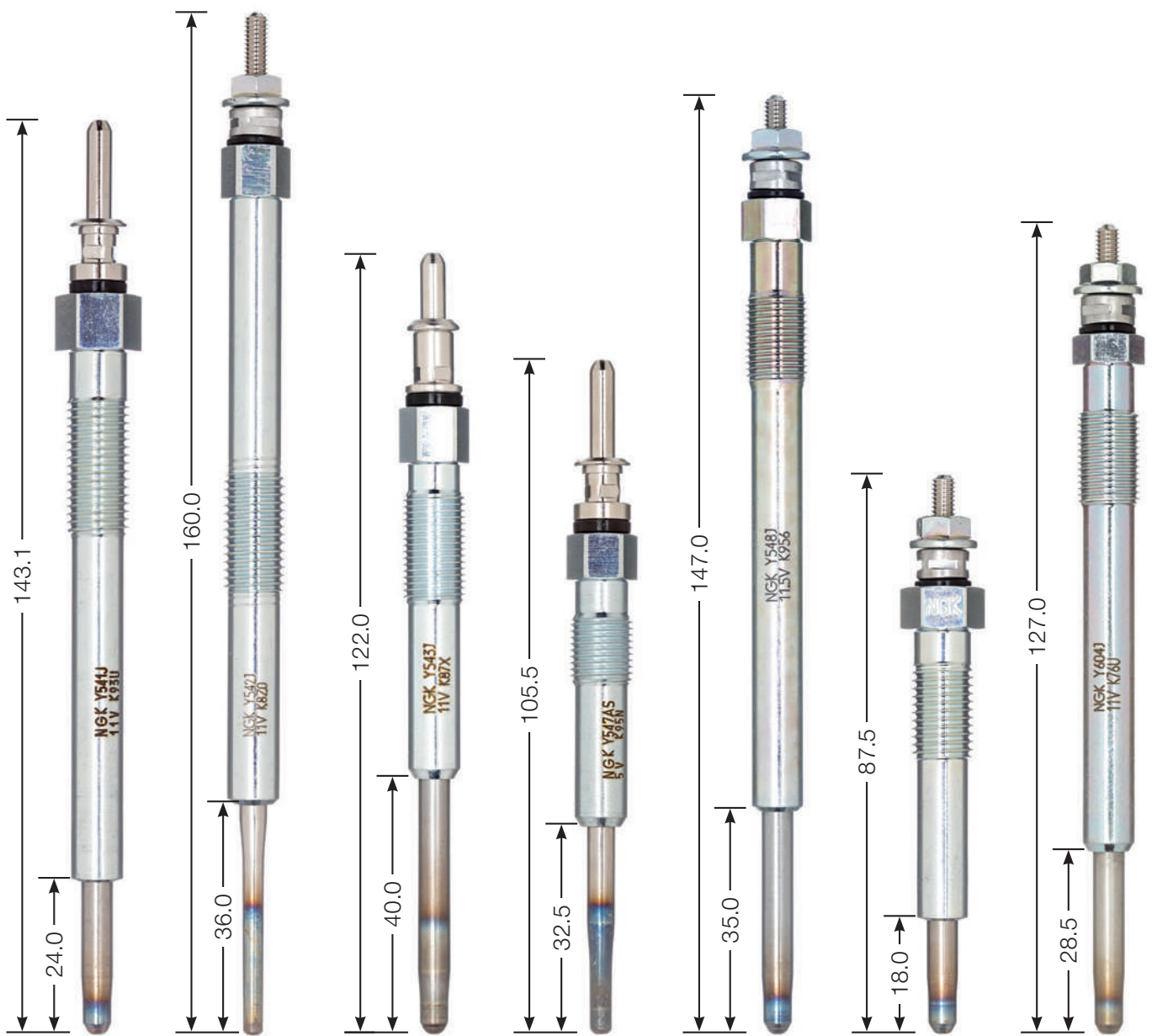

Y-541 J
 M 10 x 1.25
 12 Hex
 11 V
DP 42

Y-542 J
 M 10 x 1.25
 10 Hex
 11 V
DP 45

Y-543 J
 M 10 x 1.0
 10 Hex
 11 V
DP 46

Y-547 AS
 M 10 x 1.0
 10 Hex
 5 V
DP 47
 151

Y-548 J
 M 10 x 1.0
 10 Hex
 11.5 V
DP 75

Y-603 J
 M 10 x 1.25
 12 Hex
 11 V
DP 60

Y-604 J
 M 10 x 1.0
 10 Hex
 11 V

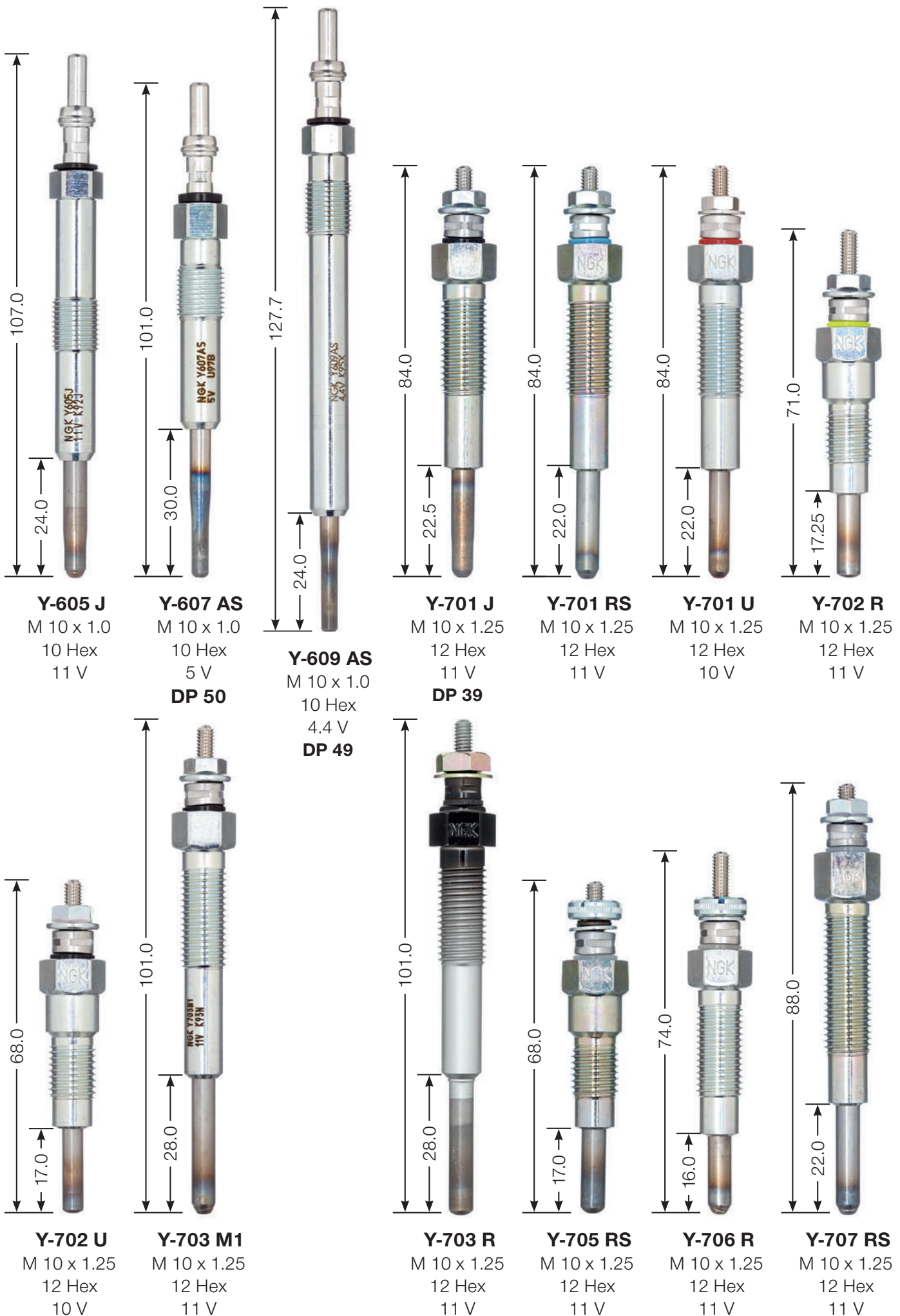

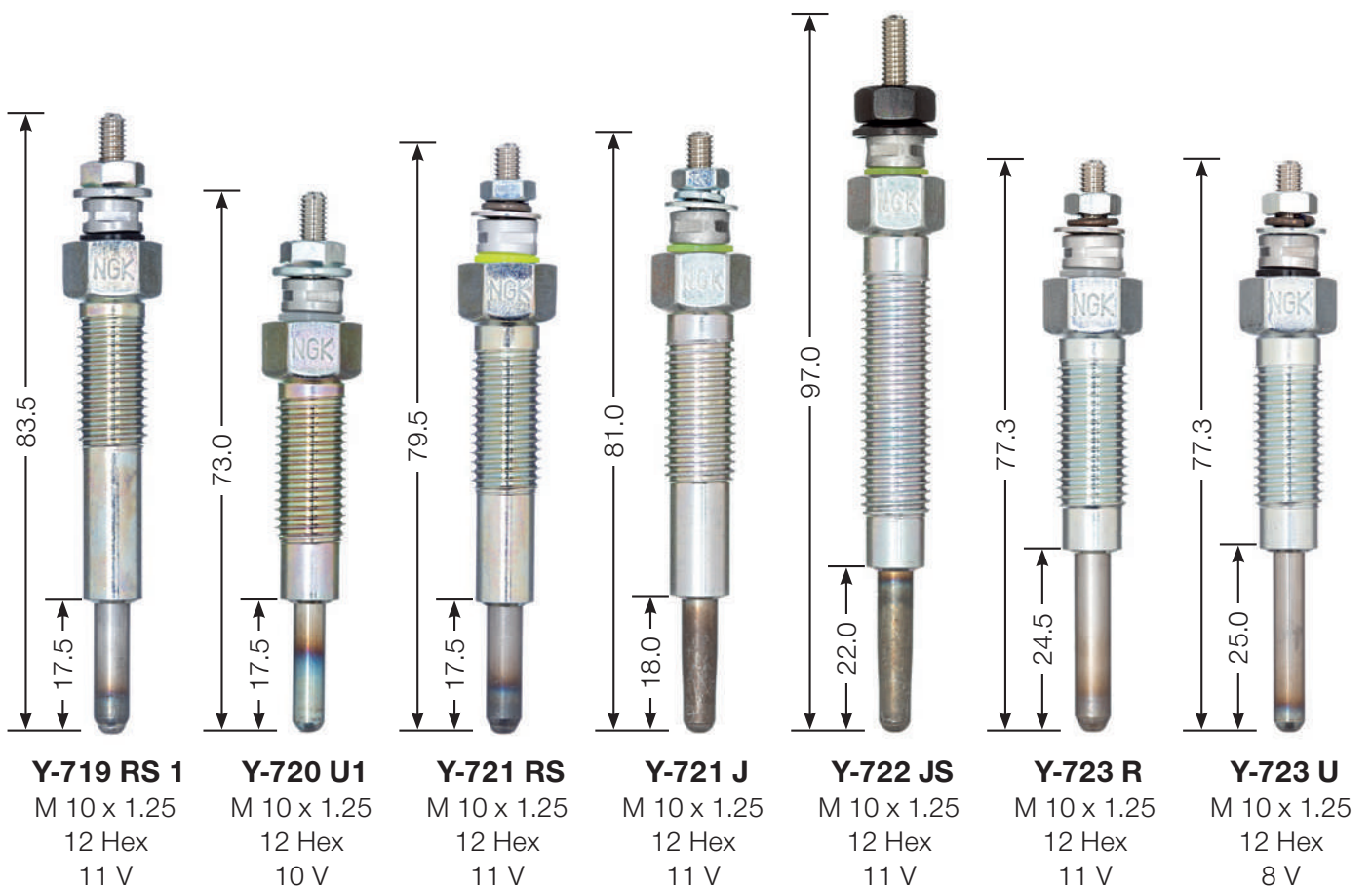
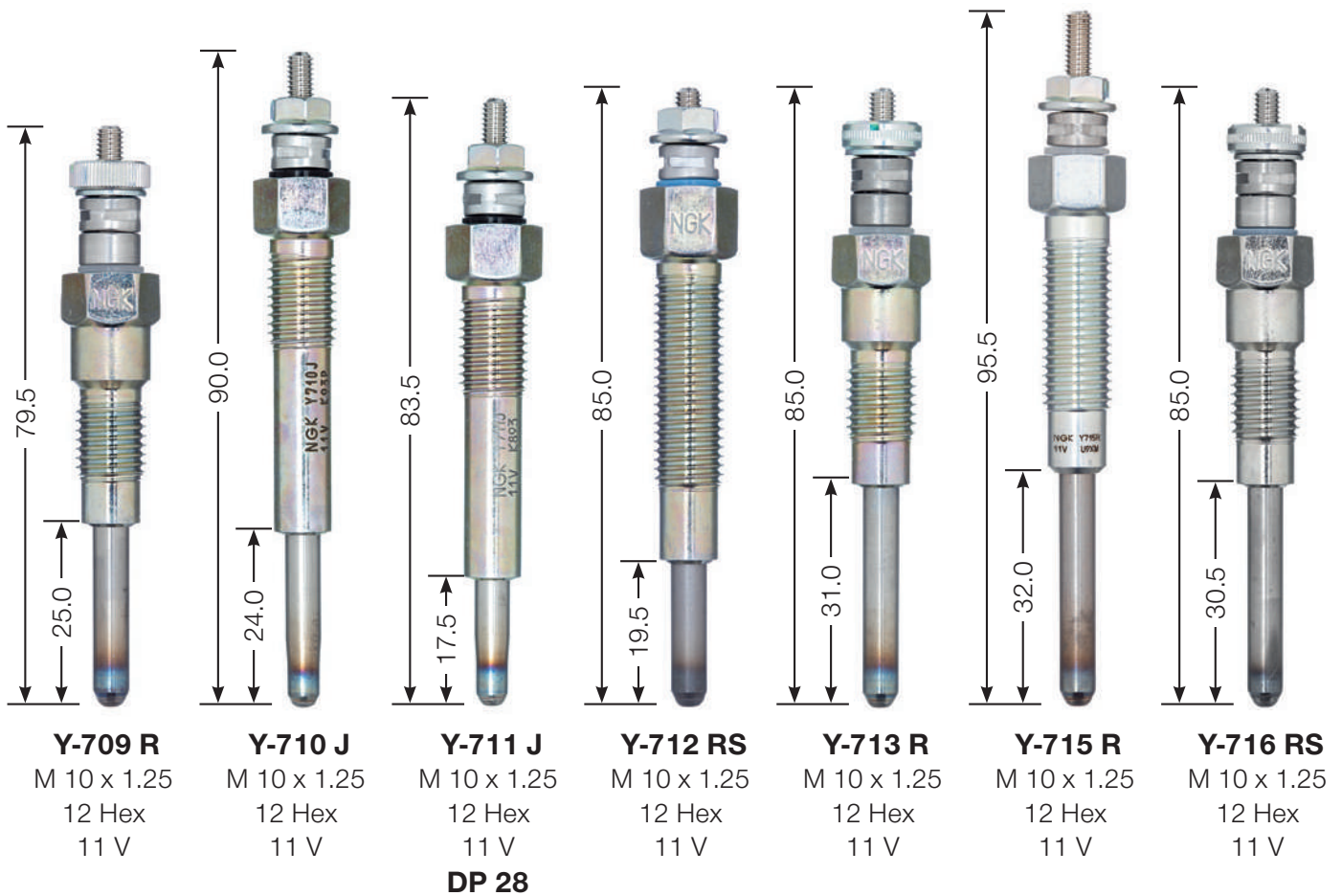

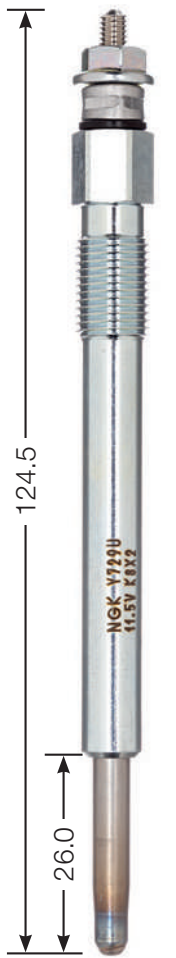

Y-729 U
M 10 x 1.0
10 Hex
10 Hex
11.5 V
DP 34



Y-730 U
M 10 x 1.0
10 Hex
11 V
DP 17



Y-732 J
M 10 x 1.0
10 Hex
12 V
DP 4

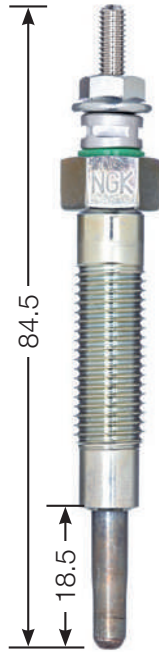

Y-733 J
M 10 x 1.25
12 Hex
11 V
DP 13



Y-738 U
M 10 x 1.0
10 Hex
11 V

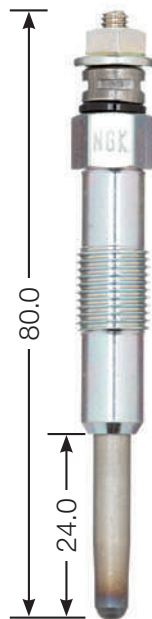

Y-739 R
M 10 x 1.0
10 Hex
11 V



Y-740 U
M 10 x 1.0
10 Hex
11 V
DP 22
154



Y-741 U
M 10 x 1.0
10 Hex
11 V
DP 20



Y-745 U
M 10 x 1.0
10 Hex
11.5 V
DP 11



Y-746 J
M 10 x 1.0
10 Hex
11.5 V
DP 38



Y-747 U
M 10 x 1.0
10 Hex
11 V
DP 26



Y-748 U
M 10 x 1.0
10 Hex
11 V
DP 14



Y-749 J
M 10 x 1.0
10 Hex
11 V

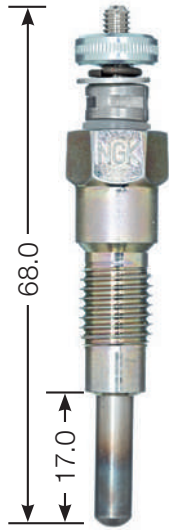

Y-755 RS
M 10 x 1.25
12 Hex
24 V

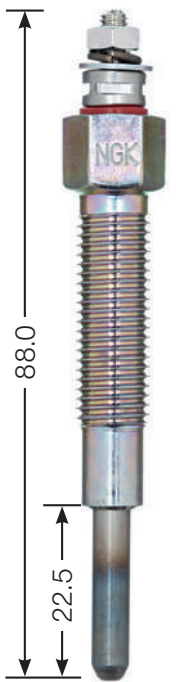

Y-757 RS
M 10 x 1.25
12 Hex
24 V

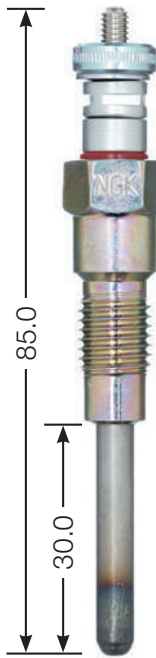

Y-766 MS
M 10 x 1.25
12 Hex
23 V

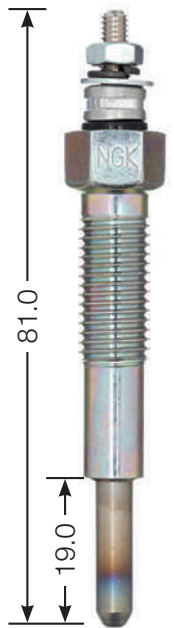

Y-771 R
M 10 x 1.25
12 Hex
24 V



Y-784 M1
M 10 x 1.25
12 Hex
23 V

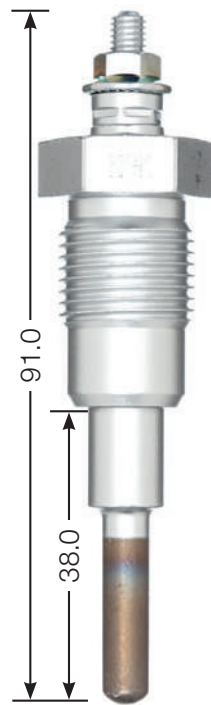

Y-810
M 18 x 1.5
20.6 Hex
10.5 V

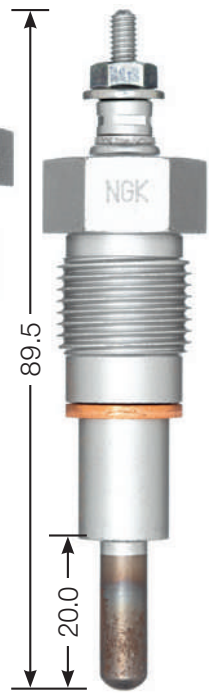

Y-874-1
M 18 x 1.5
19 Hex
22.5 V



Y-904 M1
M 12 x 1.25
12 Hex
11 V



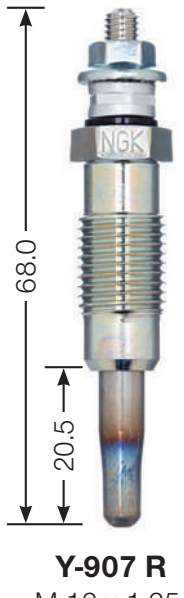

Y-907 R
M 12 x 1.25
12 Hex
11.5 V

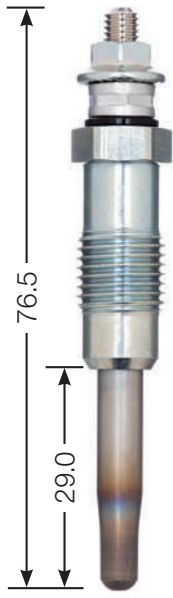

Y-909 R
M 12 x 1.25
12 Hex
11 V

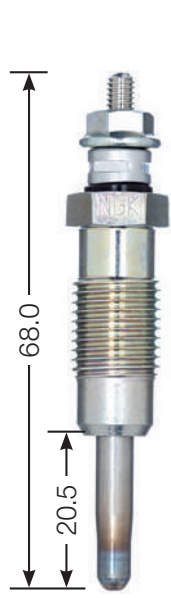

Y-910 J
M 12 x 1.25
12 Hex
11.5 V
DP 3

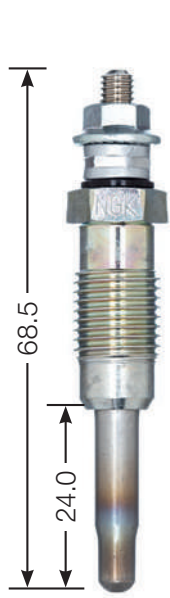

Y-913 J
M 12 x 1.25
12 Hex
11 V
DP 15



Y-916 J
M 12 x 1.25
12 Hex
11.5 V
DP 6



Y-918 J
M 12 x 1.25
12 Hex
12 V
DP 2

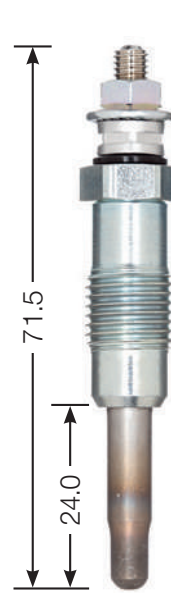

Y-924 J
M 12 x 1.25
12 Hex
11 V
DP 1



Y-925 J
M 12 x 1.25
12 Hex
11.5 V
DP 16



Y-926 U
M 12 x 1.25
12 Hex
11 V

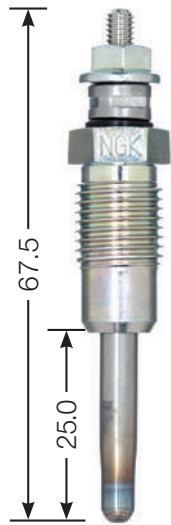

Y-927 J
M 12 x 1.25
12 Hex
11 V
DP 19



Y-928 U
M 12 x 1.25
12 Hex
11 V
DP 29
156

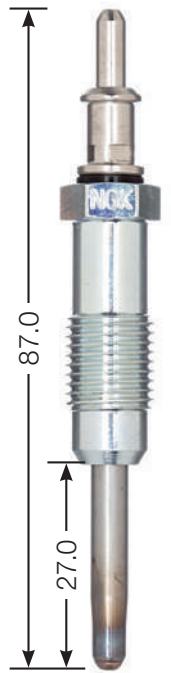

Y-929 U
M 12 x 1.25
12 Hex
11.5 V
DP 41



Y-933 J
M 12 x 1.25
12 Hex
11 V
DP 25

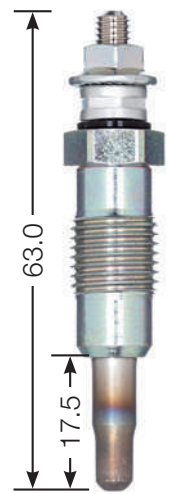

Y-937 J
M 12 x 1.25
12 Hex
10 V
DP 5



Y-930 U
M 12 x 1.25
12 Hex
11.5 V
DP 30



Y-939 J
M 12 x 1.25
12 Hex
11 V
DP 43



Y-955 RS
M 12 x 1.25
14 Hex
24 V



Y-971 M
M 12 x 1.25
12 Hex
23 V



Y1001 J1
M 10 x 1.25
12 Hex
11 V



Y1002 AS
M 10 x 1.0
10 Hex
4.4 V
DP 57



Y1003 AS
M 10 x 1.25
10 Hex
5 V





Y1005 J
M 10 x 1.0
10 Hex
11 V
DP 56

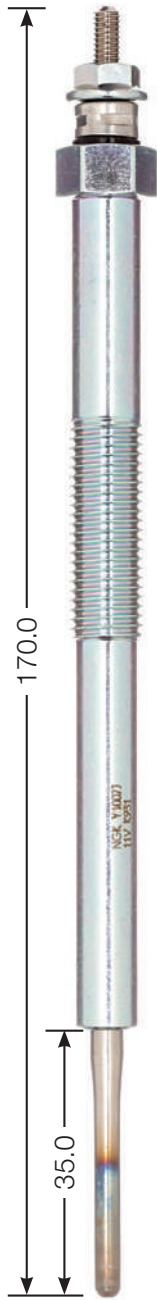

Y1007 J
M 10 x 1.25
12 Hex
11 V
DP 59

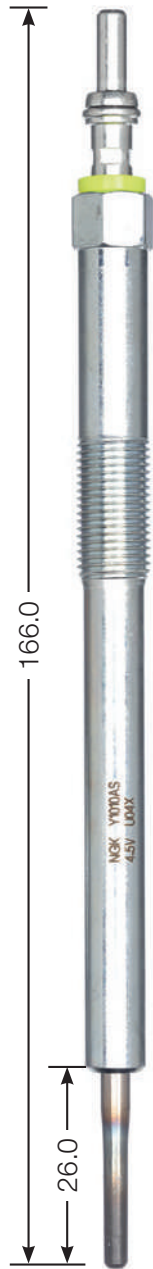

Y1010 AS
M 10 x 1.0
10 Hex
4.4 V



Y1012 J
M 10 x 1.25
10 Hex
11 V
DP 65
158



Y1030 J
M 10 x 1.0
10 Hex
11 V
DP 70



Y1031 J
M 10 x 1.0
10 Hex
11 V
DP 71

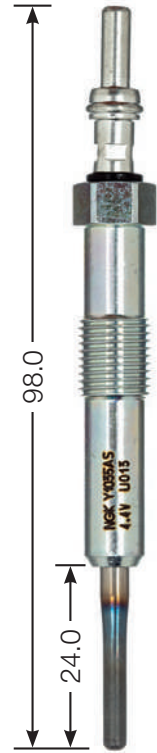

Y1035 AS
M 10 x 1.0
10 Hex
4.4 V
DP 77



Y1036 AS
M 10 x 1.0
10 Hex
4.4 V

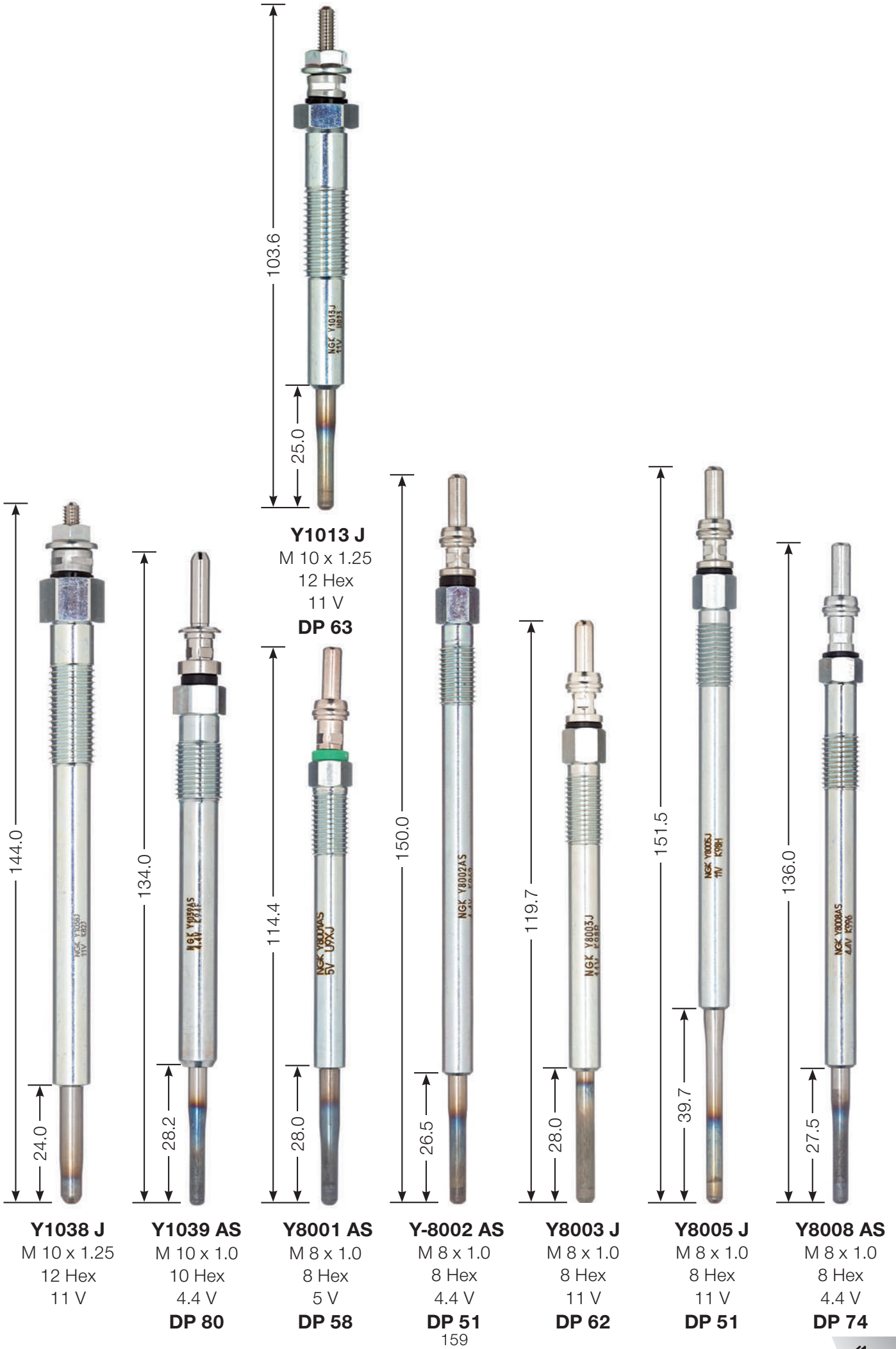



Y8009 AS
M 8 x 1.0
8 Hex
4.4 V



Y8012 AS
M 8 x 1.0
8 Hex
5 V



Y9001 AS
M 9 x 1.0
9 Hex
4.3 V
DP 72



Y9003 AS
M 9 x 1.0
9 Hex
4.4 V
DP 72
160



Y9004 AS
M 9 x 1.0
9 Hex
4.4 V
DP 72

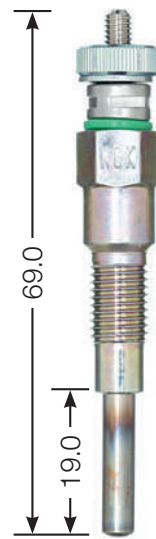

YA 01
M 8 x 1.0
10 Hex
12.5 V

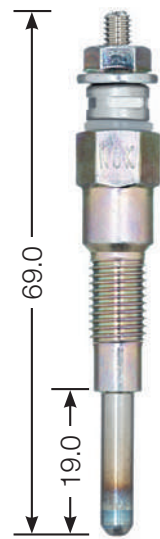

YE 01
M 8 x 1.0
10 Hex
11 V



YE 04
 M 8 x 1.0
 8 Hex
 11 V
DP 40



YE 05
 M 8 x 1.0
 8 Hex
 11 V



YE 07
 M 9 x 1.0
 9 Hex
 11 V

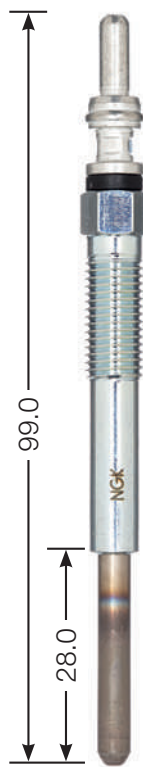

YE 08
 M 8 x 1.0
 8 Hex
 11 V



YE 12
 M 8 x 1.0
 8 Hex
 11 V



YE 13
 M 8 x 1.0
 8 Hex
 11.5 V



YE 14
 M 8 x 1.0
 8 Hex
 4.4 V
DP 48

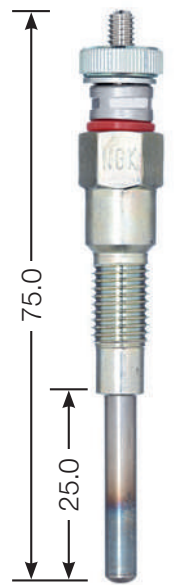

YE 52
 M 8 x 1.0
 10 Hex
 23 V





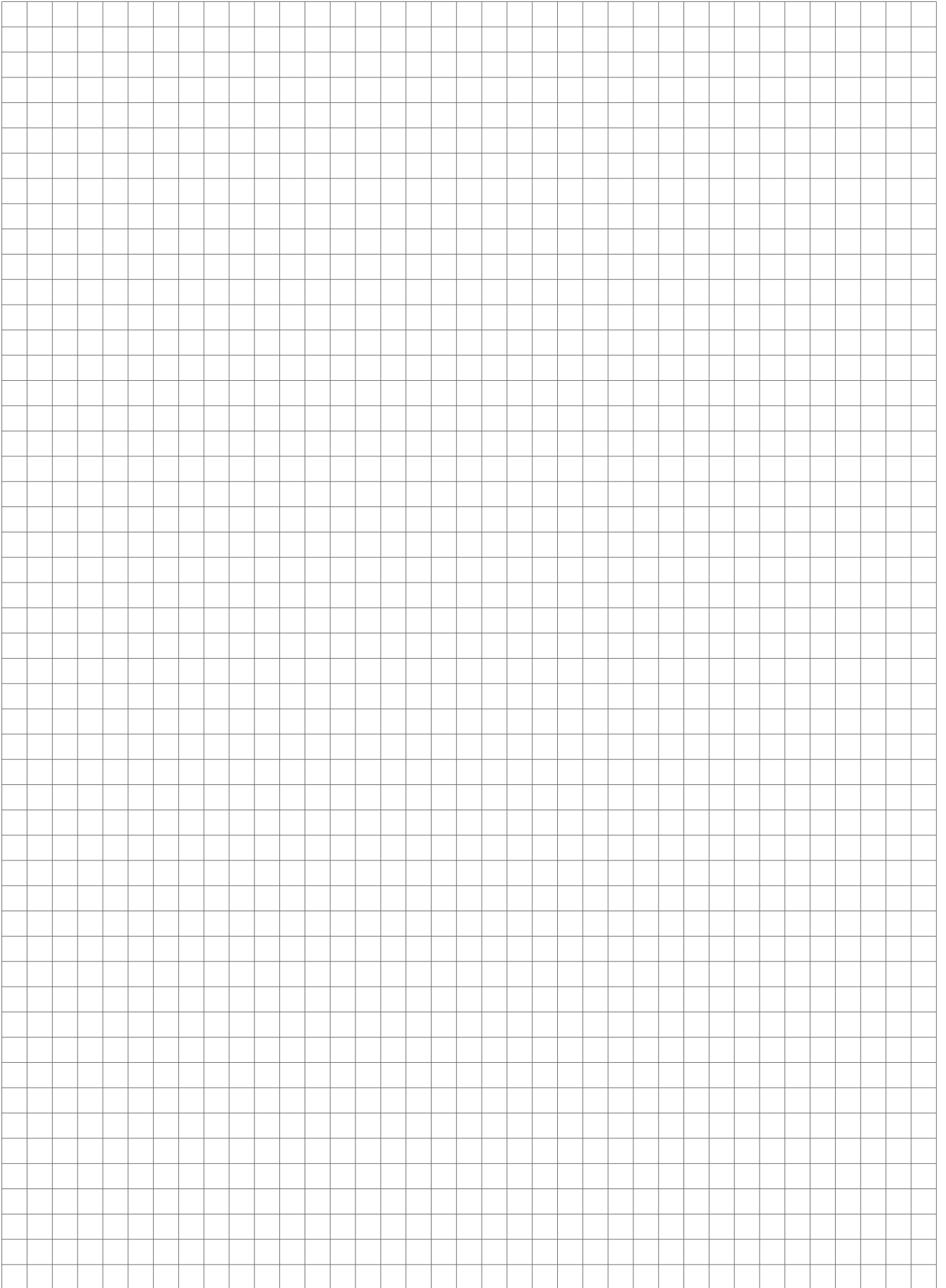

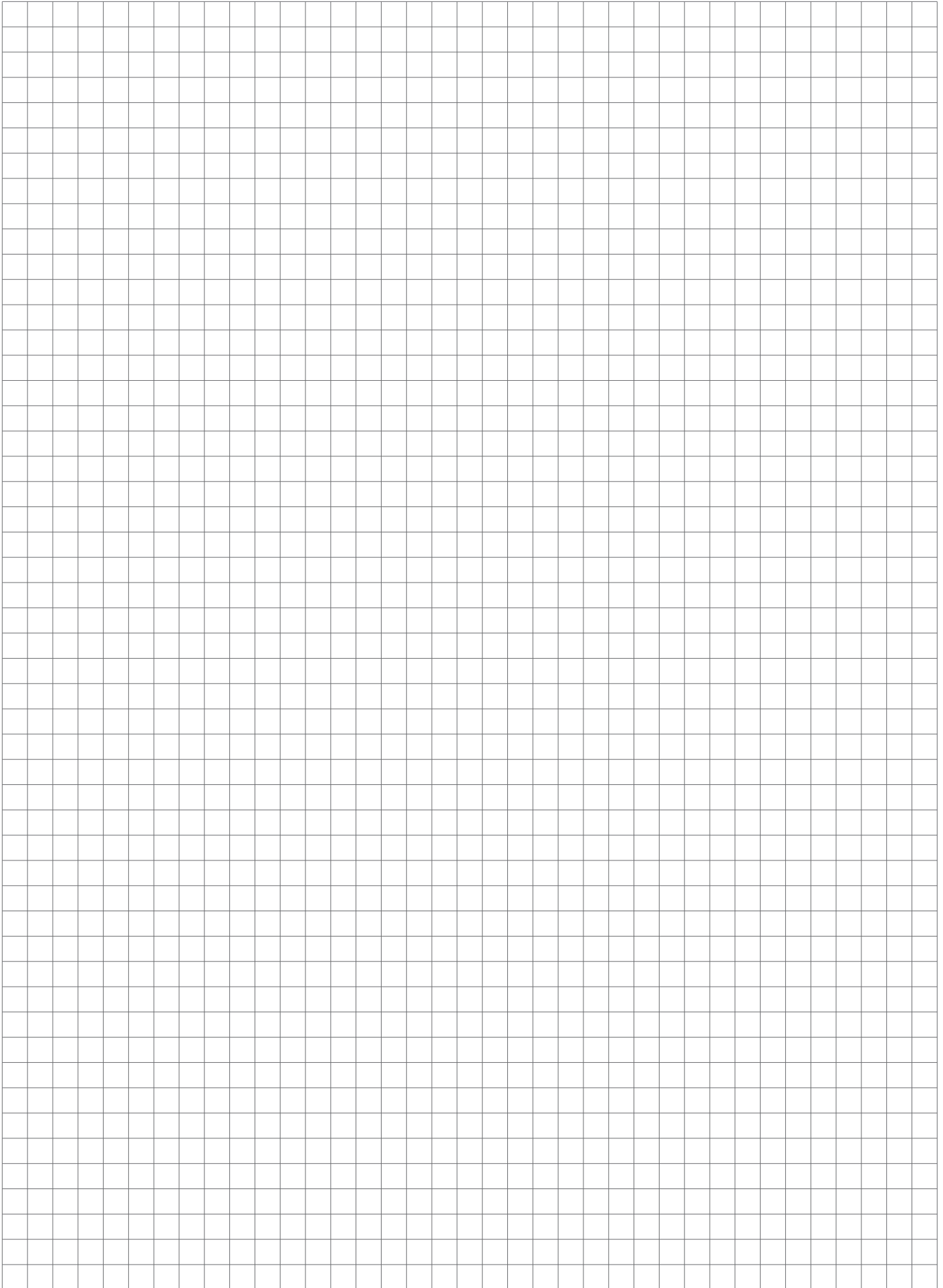



IGNITION
PARTS





l kW C Y I



Stock-Nº

VLINE

LPG/CNG

ABARTH

500 / GRANDE PUNTO / PUNTO EVO

500 C 1.4	312AXD1A	1.4	99	4	05.08-	312A1.000	0,8	IKR9J8	93311		
500 1.4 T-Jet 16V Abarth		1.4	99	4	.08-		0,8	IKR9J8	93311		
500 C 1.4 T-Jet MTA Abarth		1.4	103	4	06.10-		0,8	IKR9J8	93311		
595 1.4	312AXY11, 312AXY1A	1.4	107	4	05.16-	312B4.000	0,8	IKR9J8	93311		
Grande Punto 1.4 T-Jet 16V 180CV SS		1.4	132	4	09.09-		0,8	IKR9J8	93311		
Grande Punto 1.4 T-Jet 16V		1.4	114	4	.07-	199A8.000	0,8	IKR9J8	93311		
Punto EVO Abarth		1.4	120	4	06.10-		0,8	IKR9J8	93311		

ACURA

RSX

RSX		2.0	147	4	.02- .03	K20A2	1,1	IFR7G-11KS	7746		
RSX		2.0		4	.02- .02	K20A3	1,1	IZFR6K11	6994		

SLX

SLX		3.2		6	.96- .97	6VD1	1,1	PFR5G-11	2647		
SLX		3.5		6	.98-	6VE1	1,1	PFR5G-11	2647		

ALFA ROMEO

33

33 1.2	907A4	1.2	57	4	07.90-09.92	AR307.43	0,7	BP6ES	7811		LPG 2
33 i.e		1.3	65	4	02.94-10.94	AR307.32	0,7	BP6ES	7811	4	LPG 2
33 i.e Sport Wagon		1.3	65	4	02.94-10.94	AR307.32-AR301.68	0,7	BP6ES	7811	4	LPG 2
33 1.3 L		1.3		4	.87-01.94	AR305.02, AR305.86, AR305.87	0,7	BP6ES	7811	4	LPG 2
33 1.4 iE	907B3	1.4	66	4	07.90-09.94	AR307.55	0,7	BP6ES	7811		LPG 2
33 i.e.		1.4	66	4	01.92-12.93	AR307.53	0,7	BP6ES	7811	4	LPG 2
33 i.e.; Cat.		1.5	74	4	12.90- .93	AR307.51	0,7	BP6ES	7811	4	LPG 2
33 1.5 L		1.5	77	4	.84- .93	AR307.34-AR305.88	0,7	BP6ES	7811	4	LPG 2
33 1.7 -/iE	907A1D	1.7	77	4	07.90-09.94	AR307.37	0,7	BP6ES	7811		LPG 2
33 1.7 iE	907B1D	1.7	77	4	07.90-09.94	AR307.37	0,7	BP6ES	7811		LPG 2
33 i.e. all 1.7 Ltr.cat.		1.7	77	4	.90- .93	AR307.46, AR307.47	0,9	PFR6B	3500		LPG 1
33 1.7 iE	907B1	1.7	79	4	01.90-03.92	AR307.36	0,7	BP6ES	7811		LPG 2
33 1.7 iE	907A1	1.7	79	4	01.90-09.94	AR307.36	0,7	BP6ES	7811		LPG 2
33 i.e. - 1.7 L		1.7	85	4	.88- .93	AR305.50	0,7	BP6ES	7811	4	LPG 2
33 i.e.- 1.7 Ltr.16V		1.7	95	4	01.88-12.93	AR307.36, AR307.37	0,9	PFR6B	3500		LPG 1

75 (162B)

75 i. (Twin Spark)	162B	2.0	106	4	01.87-02.92	AR061.66 Cat.- AR062.24	0,7	BCP6ES	4930	17	LPG 3
75 i. V6	162B	2.5	110	6	09.85-02.92	AR016.46-AR019.11 Cat.	0,8	BP7ES	2412		BPR8EIX
75 i. V6	162B	3.0	133	6	01.87-02.92	AR061.20-AR061.24 Cat.	0,7	BP6ES	7811	4	LPG 2
75 i. V6	162B	3.0	139	6	02.90-02.92	AR061.503	0,7	PGR6A	4984		

4C (960)

4C 1.8 Tbi	960	1.8	177	4	03.13-	960A1.000	0,6	ILKAR7D6G	93607		
------------	-----	-----	-----	---	--------	-----------	-----	-----------	-------	--	--

8C

8C 4.7		4.7	331	8	01.07-10.10	F136YC	0,7	PMR8C-H	96361		
--------	--	-----	-----	---	-------------	--------	-----	---------	-------	--	--

145 (930)

145 1.4 i.e.	930	1.4	66	4	07.94-12.96	AR33.501	0,7	BP6ES	7811	4	LPG 2
--------------	-----	-----	----	---	-------------	----------	-----	-------	------	---	-------





l kW C
Y
I



Stock-N°

VLINE

LPG/CNG

ALFA ROMEO

145 (930)

145 1.4 i.e. 16V TS	930	1.4	76	4	12.96-01.01	AR33.503	0,9 + 0,7	BKR6EKPA + PMR7A	2513 + 4259		
145 1.6 i.e.	930	1.6	76	4	10.94-12.96	AR33.201	0,7	BP6ES	7811	4	LPG 2
145 1.6 16V TS	930	1.6	82	4	09.97-12.00	AR67.601	0,9 + 0,7	BKR6EKPA + PMR7A	2513 + 4259		
145 1.6 i.e. 16V TS	930	1.6	88	4	12.96-01.01	AR67.601	0,9 + 0,7	BKR6EKPA + PMR7A	2513 + 4259		
145 1.7 i.e. 16V	930	1.7	95	4	10.94-12.96	AR33.401	0,9	PFR6B	3500		LPG 1
145 1.8 i.e. 16V TS	930	1.8	103	4	12.96-12.98	AR67.106	0,9 + 0,7	BKR6EKPA + PMR7A	2513 + 4259		
145 1.8 i.e. 16V	930	1.8	106	4	03.98-01.01	AR32.201	0,9 + 0,7	BKR6EKPA + PMR7A	2513 + 4259		
145 2.0 (Twin Spark)	930A5	2.0	110	4	10.95-12.96	AR67.204	0,9	PFR6B	3500		LPG 1
145 2.0 16V TS	930	2.0	110	4	10.95-01.01	AR67.204	0,9 + 0,7	BKR6EKPA + PMR7A	2513 + 4259		
145 16V (Twin Spark) (Brazil)	930	2.0	110	4	12.96-04.01		0,9 + 0,7	BKR6EKPA + PMR7A	2513 + 4259		
145 2.0 16V	930	2.0	114	4	03.98-01.01	AR32.301	0,9 + 0,7	BKR6EKPA + PMR7A	2513 + 4259		

146 (930)

146 1.4 i.e.	930	1.4	66	4	08.94-02.97	AR33.501	0,7	BP6ES	7811	4	LPG 2
146 1.4 i.e.	930	1.4	66	4	07.95-11.97	AR33.201	0,7	BP6ES	7811	4	LPG 2
146 1.4 i.e. 16V TS	930	1.4	76	4	10.96-12.01	AR33.503	0,9 + 0,7	BKR6EKPA + PMR7A	2513 + 4259		
146 i 16V; L (Twin Spark)	930	1.4	76	4	02.97-03.98	AR33.503	0,9 + 0,7	BKR6EKPA + PMR7A	2513 + 4259		
146 1.4i 16V; L; Junior (Twin Spark)	930	1.4	76	4	04.98-12.01	AR33.503	0,9 + 0,7	BKR6EKPA + PMR7A	2513 + 4259		
146 1.6 i.e.	930	1.6	76	4	07.94-12.97	AR33.201	0,7	BP6ES	7811	4	LPG 2
146 1.6 16V TS	930	1.6	82	4	09.97-12.00	AR67.601	0,9 + 0,7	BKR6EKPA + PMR7A	2513 + 4259		
146 1.6 i.e. 16V TS	930	1.6	88	4	04.96-12.01	AR67.601	0,9 + 0,7	BKR6EKPA + PMR7A	2513 + 4259		
146 1.7	930	1.7	78	4	08.98-04.99	AR32.201	0,9 + 0,7	BKR6EKPA + PMR7A	2513 + 4259		
146 1.7 i.e. 16V	930	1.7	95	4	08.94-02.97	AR33.401	0,9	PFR6B	3500		LPG 1
146 1.8 i.e. 16V TS	930	1.8	103	4	10.96-12.01	AR67.106	0,9 + 0,7	BKR6EKPA + PMR7A	2513 + 4259		
146 1.8 i.e. 16V	930	1.8	106	4	03.96-10.01	AR32.201	0,9 + 0,7	BKR6EKPA + PMR7A	2513 + 4259		
146 2.0 iE (Twin Spark)	930B5	2.0	110	4	10.95-01.01	AR67.204	0,9	PFR6B	3500		LPG 1
146 2.0 16V TS	930	2.0	110	4	10.95-01.01	AR67.204	0,9 + 0,7	BKR6EKPA + PMR7A	2513 + 4259		
146 2.0 16V	930	2.0	114	4	03.98-01.01	AR32.301	0,9 + 0,7	BKR6EKPA + PMR7A	2513 + 4259		

147 (937)

147 1.6 16V (Twin Spark) 105CV	937	1.6	76	4	10.00-	AR37.203	0,8 + 0,7	BKUR6ETB + CR7EKC	6992 + 7004		
147 1.6 LPG	937AXA1A	1.6	77	4	01.09-03.10	AR37.203	0,8	BKUR6ETB	6992		
147 1.6 LPG	937AXA1A	1.6	77	4	01.09-03.10	AR37.203	0,7	CR7EKC	7004		
147 1.6 16V (Twin Spark)	937	1.6	88	4	10.00-	AR32.104	0,9 + 0,7	BKR6EKPA + PMR7A	2513 + 4259		
147 1.6 LPG	937BxB1A	1.6	88	4	03.01-12.09	AR32.104	0,9	BKR6EKPA	2513		
147 1.6 LPG	937BxB1A	1.6	88	4	03.01-12.09	AR32.104	0,7	PMR7A	4259		
147 2.0 16V (Twin Spark)	937	2.0	110	4	10.00-	AR32.310	0,9 + 0,7	BKR6EKPA + PMR7A	2513 + 4259		
147 2.0 JTS	937	2.0	125	4	10.00-	937A1.000	0,9	BKR6EKPA	2513		
147 GTA	937	3.2	184	6	11.02-05.06	932A.000	0,9	PFR6B	3500		LPG 1

155 (167)

155 i (Twin Spark)	167	1.7	86	4	02.92-04.93	AR67.103	0,7	BCP6ES	4930	17	LPG 3
--------------------	-----	-----	----	---	-------------	----------	-----	--------	------	----	-------





l kW C
Y I



Stock-N°

VLINE

LPG/CNG

ALFA ROMEO

155 (167)

155 i.T.S.	167	1.7	95	4	05.93-07.96	AR67.105	0,7	BCP6ES	4930	17	LPG 3
155 i. (Twin Spark)	167	1.8	93	4	02.92-07.96	AR67.102	0,7	BCP6E	6237	17	
155 i.T.S.	167	1.8	93	4	04.94-07.96	AR67.101, AR67.102	0,7	BCP6E	6237	17	
155 i.T.S.L	167	2.0	104	4	02.92-02.95	AR67.201, AR67.202	0,7	BCP6ES	4930	17	LPG 3
155 i.T.S.L	167	2.0	104	4	06.94-		0,7	BCP6ES	4930	17	LPG 3
155 i. (Twin Spark)	167	2.0	106	4	02.92-02.95	AR67.202	0,7	BCP6ES	4930	17	LPG 3
155 i.16V (Twin Spark)	167	2.0	110	4	06.94-01.98	AR67.204	0,9 + 0,7	BKR6EKPA + PMR7A	2513 + 4259		
155 i - Turbo- Turbo 4x4	167	2.0	137	4	08.92-04.98	AR67.203	0,8	BP6ET	1263		LPG 2
155 i.	167	2.5	120	6	02.92-	AR67.301	0,8	BPR7ES	2023	19	BPR8EIX
155 i. V6	167	2.5	120	6	02.92-04.95	AR67.301	0,8	BPR7ES	2023	19	BPR8EIX
155 i. V6	167	2.5	120	6	05.95-02.97	AR67.301	0,7	BP6ES	7811	4	LPG 2

156 (932)

156 1.6 16V (Twin Spark)	932A4	1.6	82	4	09.97-09.05	AR32.102	0,9 + 0,7	BKR6EKPA + PMR7A	2513 + 4259		
156 16V (Twin Spark)	932	1.6	88	4	12.97-05.06	AR32.101	0,9 + 0,7	BKR6EKPA + PMR7A	2513 + 4259		
156 16V (Twin Spark)	932	1.8	106	4	12.97-05.06	AR32.201	0,9 + 0,7	BKR6EKPA + PMR7A	2513 + 4259		
156 2.0 16V (Twin Spark)	932	2.0	114	4	12.97-12.02	AR32.301	0,9 + 0,7	BKR6EKPA + PMR7A	2513 + 4259		
156 2.0 16V (Twin Spark) Selespeed	932	2.0	114	4	05.99-12.02	AR32.301	0,9 + 0,7	BKR6EKPA + PMR7A	2513 + 4259		
156 2.0 JTS	932AXD00, 932AXD01, 932BXD00, 932BXD01	2.0	119	4	03.01-05.06	932A.2000	0,9	BKR6EKPA	2513		
156 2.0 JTS	932	2.0	121	4	11.01-05.06	937A.1000	0,9	BKR6EKPA	2513		
156 2.5 24V	932	2.5	140	6	10.97-05.06	AR32.401	0,9	PFR6B	3500		LPG 1
156 3.2 GTA	932	3.2	184	6	11.02-05.06	932A.000	0,9	PFR6B	3500		LPG 1

159 (939)

159 1.8	939BXL1A, 939AXL1A	1.8	103	4	06.05-11.11	939A4.000	1,1	ZFR5F-11	2262	40	LPG6
159 1.8 16V	939	1.8	103	4	07.05-11.11	939A4.000	1,1	ZFR5F-11	2262	40	LPG6
159 1750 TBi	939	1.8	147	4	05.09-11.11	939B1.000	0,6	ILKAR7D6G	93607		
159 1.9 JTS 16V	939	1.9	118	4	07.05-11.11	939A6.000	0,8	FR5CP	6368		
159 2.2 JTS 16V	939	2.2	136	4	07.05-11.11	939A5.000	0,8	FR5CP	6368		

164 (164)

164 i.T.S.	164	2.0	102	4	06.87-09.92	AR064.16Cat-AR064.20	0,7	BCP6ES	4930	17	LPG 3
164 i.T.S Super / Super L	164	2.0	106	4	07.94-10.98	AR67.201, AR67.202	0,7	BCP6ES	4930	17	LPG 3
164 i.e. Turbo	164	2.0	126	4	01.88-09.92	AR064.76	0,8	BPR7ES	2023	19	BPR8EIX
164 i. V6 turbo Super	164	2.0	148	6	03.91-10.98	AR64.102	0,8	BP7ES	2412		BPR8EIX
164 i.	164	2.0			03.91-		0,8	BP7ES	2412		BPR8EIX
164 i. V6 Super	164	3.0	132	6	01.96-		0,7	PGR6A	4984		
164 i. V6 12V	164	3.0	138	6	01.90-10.98	AR64.305	0,7	BP6ES	7811	4	LPG 2
164 i. V6 24V CF2	164	3.0	155	6	01.87- .92	AR64.301	0,7	PGR6A	4984		
164 i. V6 12V	164	3.0	155	6	.92-10.98	AR66.301	0,9	PFR6B	3500		LPG 1
164 i. V6 24V Super	164	3.0	155	6	07.94-10.98	AR64.304-AR64.308	0,9	PFR6B	3500		LPG 1
164 i. V6 QV	164	3.0	169	6	-10.98	AR16.102	0,7	PGR6A	4984		
164 i. Q.4	164	3.0	171	6	01.90-10.98	AR64.304	0,9	PFR6B	3500		LPG 1
164 12V	164	3.0		6	06.87-09.93	AR06.410, AR06.412	0,7	B7ES	1111		BR8EIX





l kW C Y I



Stock-N°

VLINE

LPG/CNG

ALFA ROMEO

166 (936)

166 2.0 16V (Twin Spark)	936	2.0	114	4	11.98-06.06	AR34.103	0,9 + 0,7	BKR6EKPA + PMR7A	2513 + 4259		
166 2.0 TS	936	2.0	125	4	11.03-06.06	AR36301	0,9 + 0,7	BKR6EKPA + PMR7A	2513 + 4259		
166 2.0 V6 Turbo Super;Prog.Distint.	936	2.0	151	6	11.98-06.06	AR34.102	0,8	BP6E	5637	4	LPG 2
166 24V V6 (Brazil)	936	2.0	151		10.98-06.06		0,9	PFR6B	3500		LPG 1
166 2.5 I V6 24V	936	2.5	140	6	11.98-06.06	AR34.201	0,9	PFR6B	3500		LPG 1
166 3.0 I V6 24V	936	3.0	162	6	11.98-06.06	AR34.301	0,9	PFR6B	3500		LPG 1
166 3.2 V6 24V	936	3.2	176	6	11.03-06.06	936A.6000	0,9	PFR6B	3500		LPG 1

BRERA

Brera 1750 TBI		1.8	147	4	03.09-03.11	939B1.000	0,6	ILKAR7D6G	93607		
Brera 2.2 JTS		2.2	136	4	09.05-03.11	939A5.000	0,8	FR5CP	6368		

GIULIA (952)

Giulia 2.0	952ABA25B	2.0	147	4	08.16-		0,7	ILZKR7G7G	90219		
Giulia 2.0	952ACA45	2.0	206	4	08.16-		0,7	ILZKR7G7G	90219		
Giulia 2.9	952AAM24	2.9	375	6	10.15-		0,7	LKAR8AP7JDS	96748		

GIULIETTA (940)

Giulietta 1.4 TB	940	1.4	77	4	04.11-	940B1.000	0,8	IKR9J8	93311		
Giulietta 1.4 TB	940	1.4	85	4	04.10-	940A6.000, 198A6.000	0,8	IKR9J8	93311		
Giulietta 1.4 TB	940	1.4	88	4	03.10-	198A4.000	0,8	IKR9J8	93311		
Giulietta 1.4 TB BiFuel	940	1.4	88	4	12.11-	198A4.000	0,8	IKR9J8	93311		
Giulietta 1.4 TB	940	1.4	120	4	04.10-	955A8.000	0,8	IKR9J8	93311		
Giulietta 1.4 TB	940	1.4	125	4	03.10-	940A2.000	0,8	IKR9J8	93311		
Giulietta 1750 Tbi Quadrifoglio Verde	940	1.8	173	4	03.10-	940A1.000	0,6	ILKAR7D6G	93607		
Giulietta 1750 Tbi Quadrifoglio Verde	940	1.8	177	4	09.13-	960A1.000	0,6	ILKAR7D6G	93607		

GT (937)

GT 1.8 16V TS	937	1.8	103	4	12.03-	AR32.205	0,9 + 0,7	BKR6EKPA + PMR7A	2513 + 4259		
GT 2.0 JTS	937CXH11, 937CXH1A	2.0	119	4	05.06-09.10	932A.2000	0,9	BKR6EKPA	2513		
GT 2.0 JTS	937	2.0	121	4	12.03-	937A1.000	0,9	BKR6EKPA	2513		
GT	937CXP1B	3.2	176	6	12.03-12.04	936A.000	0,9	PFR6B	3500		LPG 1

GTV (916)

GTV i 16V (Twin Spark)	916	1.8	106	4	06.98-06.02	AR32.201	0,9 + 0,7	BKR6EKPA + PMR7A	2513 + 4259		
GTV 16V (Twin Spark)	916	2.0	110	4	04.95-05.98	AR16.201	0,9 + 0,7	BKR6EKPA + PMR7A	2513 + 4259		
GTV 2.0 L 16V (Twin Spark)	916	2.0	110	4	06.98-	AR32.301	0,9 + 0,7	BKR6EKPA + PMR7A	2513 + 4259		
GTV 2.0 JTS 16V	916	2.0	121	4	06.03-	937A1.000	0,9	BKR6EKPA	2513		
GTV V6 Turbo	916	2.0	147	6	04.95-05.98	AR16.202	0,8	BP7ES	2412		BPR8EIX
GTV 2.0 L V6 turbo L	916	2.0	148	6	06.98-12.99	AR16.202	0,9	BPR6E	6464	2	LPG 2
GTV V6 12V	916	2.0	151	6	09.97-12.00		0,8	BPR7ES	2023	19	BPR8EIX
GTV V6 24V- L	916	3.0	160	6	11.96-12.00	AR16.102	0,9	PFR6B	3500		LPG 1
GTV V6 24V	916	3.0	162	6	02.97-05.98	AR67.601	0,9	PFR6B	3500		LPG 1
GTV V6 24V	916	3.2	176	6	06.03-	936A.6000	0,9	PFR6B	3500		LPG 1

MITO (955)

MITO 0.9 TwinAir	955	0.9	63	2	07.11-	312A2.000	0,8	ILKR9G8	97168		
MITO 0.9 TwinAir	955	0.9	77	2	04.13-	199B6.000	0,8	ILKR9G8	97168		
MITO 1.4	955	1.4	51	4	05.11-	955A9.000	1,0	ZKR7A-10	1691	42	LPG 8



e kW C
Y I

Stock-N°

VLINE

LPG/CNG

ALFA ROMEO**MITO (955)**

MITO 1.4	955	1.4	57	4	03.11-	350A1.000	1,0	ZKR7A-10	1691	42	LPG 8
MITO 1.4	955	1.4	58	4	09.08-	955A1.000	1,0	ZKR7A-10	1691	42	LPG 8
MITO 1.4	955	1.4	70	4	09.08-	199A6.000	1,0	ZKR7A-10	1691	42	LPG 8
MITO 1.4 16V Multiair	955	1.4	77	4	10.09-	955A6.000	1,0	DCPR7E-N-10	4983	43	
MITO 1.4 T-Jet	955	1.4	88	4	09.08-	198A4.000	0,8	IKR9J8	93311		
MITO 1.4 T-Jet Bifuel LPG	955	1.4	88	4	10.09-	198A4.000	0,8	IKR9J8	93311		
MITO 1.4 TB 16V Multiair	955	1.4	99	4	08.09-	955A2.000, 955A7.000	0,8	IKR9J8	93311		
MITO 1.4 T-Jet	955	1.4	110	4	09.08-06.11	198A1.000	0,8	IKR9J8	93311		
MITO 1.4 TB	955	1.4	114	4	09.08-	199A8.000	0,8	IKR9J8	93311		
MITO 1.4 TB	955	1.4	120	4	10.09-	955A8.000	0,8	IKR9J8	93311		
MITO 1.4 TB	955	1.4	125	4	12.09-	940A2.000	0,8	IKR9J8	93311		

SPIDER (115)

Spider i.	115	2.0	86	4	01.90-12.94	AR015.44, AR015.88, AR015.90 Cat.	0,7	BP6ES	7811	4	LPG 2
-----------	-----	-----	----	---	-------------	-----------------------------------	-----	-------	------	---	-------

SPIDER (916)

Spider 16V (Twin Spark)	916	1.8	103	4	06.98-03.01	AR32.201	0,9 + 0,7	BKR6EKPA + PMR7A	2513 + 4259		
Spider 16V (Twin Spark)	916	2.0	110	4	04.95-05.98	AR16.201	0,9 + 0,7	BKR6EKPA + PMR7A	2513 + 4259		
Spider 16V (Twin Spark)	916	2.0	114	4	06.98-	AR32.301	0,9 + 0,7	BKR6EKPA + PMR7A	2513 + 4259		
Spider 2.0 JTS 16V	916	2.0	121	4	06.03-	937A.1000	0,9	BKR6EKPA	2513		
Spider i V6 turbo	916	2.0	147	6	06.98-12.99	AR16.202	0,9	BPR6E	6464	2	LPG 2
Spider i V6 12V	916	3.0	140	6	04.95-05.98	AR16.101, AR16.199	0,8	BPR6ES	7822	2	LPG 2
Spider 3.0 V6 24V	916	3.0	165	6	06.98- .04	AR16.102	0,9	PFR6B	3500		LPG 1
Spider 3.2 V6 24V	916	3.2	176	6	06.03-	936A6.000	0,9	PFR6B	3500		LPG 1

SPIDER (939)

Spider 1750 TBi	939	1.8	147	4	03.09-	939B1.000	0,6	ILKAR7D6G	93607		
Spider 2.2 JTS	939	2.2	136	4	01.06-	939A5.000	0,8	FR5CP	6368		

SPRINT

Sprint Veloce		1.3	64	4	01.90-	AR301.68	0,7	BP6ES	7811	4	LPG 2
---------------	--	-----	----	---	--------	----------	-----	-------	------	---	-------

STELVIO (949)

Stelvio 2.0	949AXF2A	2.0	148	4	12.16-		0,7	ILZKR7G7G	90219	4	
Stelvio 2.0	949AXA2A	2.0	206	4	12.16-		0,7	ILZKR7G7G	90219	4	
Stelvio 2.9	949	2.9	375	6	11.17-		0,7	LKAR8AP7JDS	96748		
Stelvio 2.9 Racing	949AXG2A	2.9	383	6	11.19-		0,7	LKAR8AP7JDS	96748		

SZ

SZ V6 / RZ V6		3.0	152	6	03.90-05.96	AR64.304	0,7	PGR6A	4984		
---------------	--	-----	-----	---	-------------	----------	-----	-------	------	--	--

ALPINA**B 10**

B10 3.2	E39	3.2	191	6	08.97-12.98	S52B32	0,9	BKR6EK	2288	20	LPG 1
B10 3.3	E39	3.3	206	6	02.99-10.03	S52B33	1,5	BKR6EQUP	3199	30	LPG 1
B10 3.5	E34	3.5	187	6	04.88-12.92	B11, 3	0,8	BPR6ES	7822	2	LPG 2
B10 3.5 Biturbo	E34	3.5	265	6	08.89-03.94	B7, 5	0,8	BPR6ES	7822	2	LPG 2
B10 4.0	E34	4.0	232	8	04.93-08.95	F1	1,5	BKR6EQUP	3199	30	LPG 1
B10 4.6	E34	4.6	250	8	03.94-04.96	F2	1,5	BKR6EQUP	3199	30	LPG 1
B10 4.6 V8	E39	4.6	250	8	12.96-10.98	M62B46	0,9	BKR6EK	2288	20	LPG 1





l kW C
y i



Stock-Nº

VLINE

LPG/CNG

ALPINA

B 10

B10 4.6 V8	E39	4.6	255	8	10.98-08.00	M62B46	1,5	BKR6EQUP	3199	30	LPG 1
B10 4.8 V8S	E39	4.8	276	8	01.02-12.03	M62B48	1,5	BKR6EQUP	3199	30	LPG 1

B 12

B12 5.7 E-Kat	E38	5.7	285	12	12.95-09.98	M73B57	0,9	BKR6EK	2288	20	LPG 1
B12 6.0 E-Kat	E38	6.0	316	12	06.99-07.01	M73B60	1,5	BKR6EQUP	3199	30	LPG 1

B 3

B3 3.0	E36	3.0	184	6	04.93-03.96	M50B30	0,9	BKR6EK	2288	20	LPG 1
B3 3.2	E36	3.2	195	6	04.96-03.99	S52B32	0,9	BKR6EK	2288	20	LPG 1
B3 3.2 Cabrio	E36	3.2	195	6	04.96-03.99	S52B32	0,9	BKR6EK	2288	20	LPG 1
B3 3.3	E46	3.3	206	6	03.99-01.05	S52B33	1,5	BKR6EQUP	3199	30	LPG 1

B 3 S

B3 S 3.3	E46	3.3	224	6	08.02-01.06	S52B33	1,5	BKR6EQUP	3199	30	LPG 1
----------	-----	-----	-----	---	-------------	--------	-----	----------	------	----	-------

B 5

B5 4.4	E60	4.4	368	8	03.05-	S62B44 H1/2	0,6	PFR7B	4853		
B5 4.4 Biturbo	F10	4.4	373	8	.10-	M1	0,8	SIZKBR8A8HS	1555		

B 5 S

B5 S 4.4	E60	4.4	390	8	.07-	S62B44 H1/2	0,6	PFR7B	4853		
----------	-----	-----	-----	---	------	-------------	-----	-------	------	--	--

B 6

B6 4.4 Cabrio	E64	4.4	368	8	10.05-	S62B44 H1/2	0,6	PFR7B	4853		
---------------	-----	-----	-----	---	--------	-------------	-----	-------	------	--	--

B 6 S

B6 S 4.4 Cabrio	E64	4.4	390	8	.07-	S62B44 H1/2	0,6	PFR7B	4853		
-----------------	-----	-----	-----	---	------	-------------	-----	-------	------	--	--

B 7

B7 4.4	E65	4.4	368	8	03.05-	S62B44 H1/2	0,6	PFR7B	4853		
B7 4.4 Biturbo	F01	4.4	373	8	05.09-	M1	0,8	SIZKBR8A8HS	1555		

B 8

B8 4.6	E36	4.6	245	8	01.95-11.98	M62B46	0,9	BKR6EK	2288	20	LPG 1
--------	-----	-----	-----	---	-------------	--------	-----	--------	------	----	-------

ROADSTER S

Roadster S 3.4	E85	3.4	221	6	07.03-12.05	E5/2	1,5	BKR6EQUP	3199	30	LPG 1
----------------	-----	-----	-----	---	-------------	------	-----	----------	------	----	-------

ROADSTER V8

Roadster 4.8 V8	E52	4.8	280	8	06.02-10.03	S62 B48	1,5	BKR6EQUP	3199	30	LPG 1
-----------------	-----	-----	-----	---	-------------	---------	-----	----------	------	----	-------

ARO

SPARTANA

Spartana 1.2		1.2	40	4	.97-	C3GD7	0,9	BP5ESZ	4691		LPG 2
--------------	--	-----	----	---	------	-------	-----	--------	------	--	-------

ASIA MOTORS

ROCSTA

Rocsta 1.8		1.8	57	4	02.94-12.97	F8	0,9	BPR5ES	7422	6	LPG 2
------------	--	-----	----	---	-------------	----	-----	--------	------	---	-------

ASTON MARTIN

DB 7

DB 7 3.2		3.2	250	6	09.94-06.99		0,8	BCPR7ES	3330		BCPR7EIX
DB 7 5.9		5.9		12	07.99-11.00		1,3	PTR6D-13	5598		LPG 5
DB 7 5.9		5.9		12	11.00-		1,3	PTR5D-13	6644		

DB 7 VANTAGE

3.2 Turbo 24V Coupe, Cabriolet		3.2	246	6	.95-		0,7	BCPR7ES	3330		BCPR7EIX
48V V12		6.0	420	12	04.00-		1,0	PTR5D-10	3784	31	LPG 5



e kW C
Y I

Stock-N°

VLINE

LPG/CNG

ASTON MARTIN**DB 9**

DB 9 5.9	R1A22, R1B42	5.9	380	12	07.12-	AM11	1,1	SITR7A11G	94949		
DB 9 5.9 GT	R1A22, R1B42	5.9	403	12	04.16-	AM11	1,1	SITR7A11G	94949		

RAPIDE

Rapide 5.9	AMR	5.9	410	12	02.13-	AM11	1,1	SITR7A11G	94949		
------------	-----	-----	-----	----	--------	------	-----	-----------	-------	--	--

V12

V12 5.9	R2C92	5.9	421	12	01.13-	AM28	1,1	SITR7A11G	94949		
---------	-------	-----	-----	----	--------	------	-----	-----------	-------	--	--

V8 VANTAGE

V8 Vantage 4.3	AM305	4.3	283	8	05.05-12.08	AM6U5	1,0	IFR7N10	97105		
V8 Vantage 4.3 N400	AM305	4.3	298	8	01.08-12.10	AM6U5	1,0	IFR7N10	97105		
V8 Vantage 4.7	AM305	4.7	313	8	10.08-	AM07, AM14	1,0	IFR7N10	97105		
V8 Vantage 4.7 /AMR/N430/S	AM305	4.7	321	8	01.11-	AM15	1,0	IFR7N10	97105		
V8 Vantage 4.7 SP10	AM305	4.7	328	8	07.13-	AM15	1,0	IFR7N10	97105		

VANQUISH

Vanquish 5.9	AM310	5.9	421	12	10.12-	AM11	1,1	SITR7A11G	94949		
Vanquish 5.9		5.9		12	06.01-	AM 702	1,3	PTR6D-13	5598		LPG 5

VANTAGE

Vantage 5.3		5.3	410	8	08.93-	10.2:1Comp(Zagato)	0,8	BCR8ES	5430		
-------------	--	-----	-----	---	--------	--------------------	-----	--------	------	--	--

VIRAGE

Virage / Volante 5.3		5.3		8	02.90-01.98	V8 32V	0,8	BCPR6E	1269	12	LPG 3
----------------------	--	-----	--	---	-------------	--------	-----	--------	------	----	-------

AUDI**80 (B4)**

80 1.6	B4	1.6	52	4	08.91-06.94	ABM	0,8	BUR5ET	3377	22	LPG 2
80 1.6	B4	1.6	74	4	06.93-07.95	ADA	0,8	BUR6ET	3172	1	LPG 2
80 2.0	B4	2.0	66	4	09.91-06.95	ABT	0,8	BUR6ET	3172	1	LPG 2
80 Quattro 2.0	8C2	2.0	79	4	11.93-05.95	ADW	0,8	BUR6ET	3172	1	LPG 2
80 Quattro 2.0	8C5	2.0	79	4	11.93-07.95	ADW	0,8	BUR6ET	3172	1	LPG 2
80 2.0 E	B4	2.0	85	4	09.91-07.95	ABK	0,8	BUR6ET	3172	1	LPG 2
80 2.0	8C2	2.0	85	4	09.91-05.95	ABK	0,8	BUR5ET	3377	22	LPG 2
80 Quattro 2.0	8C2	2.0	85	4	09.91-12.94	ABK	0,8	BUR5ET	3377	22	LPG 2
80 2.0	8C5	2.0	85	4	08.92-07.95	ABK	0,8	BUR5ET	3377	22	LPG 2
80 2.0 E 16V	B4	2.0	103	4	08.92-07.95	ACE	0,8	BKUR7ET	7873		
80 S2 quattro	B4	2.2	169	5	02.93-07.95	ABY	0,6	PFR7B	4853		
80 avant RS2 quattro	B4	2.2	232	5	03.94-07.95	ADU	0,6	PFR7B	4853		
80 2.3 E	B4	2.3	98	5	09.91-12.94	NG	0,8	BUR5ET	3377	22	LPG 2
80 2.6 E	B4	2.6	110	6	07.92-07.95	ABC	1,0	BKUR6ET-10	2397	24	LPG 1
80 2.8 E	B4	2.8	128	6	09.91-07.95	AAH	1,0	BKUR6ET-10	2397	24	LPG 1

100 (C4)

100 2.0	4A2, 4A5	2.0	85	4	12.90-07.94	AAD, ABK	0,8	BP5ET	2287		LPG 2
100 2.0	4A5	2.0	85	4	12.90-07.94	ABK	0,8	BP5ET	2287		LPG 2
100 2.0	4A5	2.0	103	4	07.92-07.94	ACE	0,8	BKUR7ET	7873		

A1 (8X)

A1 1.0 TFSi	8XK	1.0	60	3	01.16-	CHZE	0,8	PKER7A8EGS	95463		
A1 Sportback 1.0 TFSi	8XF	1.0	60	3	01.16-	CHZE	0,8	PKER7A8EGS	95463		
A1 1.0 TFSi	8XK	1.0	70	3	03.15-	CHZB	0,8	PKER7A8EGS	95463		





l kW C
Y
I



Stock-N°

VLINE

LPG/CNG

AUDI

A1 (8X)

A1 Sportback 1.0 TFSi	8XF	1.0	70	3	03.15-	CHZB	0,8	PKER7A8EGS	95463		
A1 1.2 TFSi	8X1, 8XA	1.2	63	4	05.10-	CBZA	0,7	IZFR6P7	97153		
A1 1.4 TFSi (KW<103)	8X1, 8XA	1.4	90	4	05.10-	CAXA	0,9	PZFR6R	5758	52	
A1 1.4 TFSi	8XK, 8XF	1.4	92	4	11.14-	CZCA	0,8	PZKER7B8EGS	93231	55	
A1 1.4 TFSi (KW>=103)	8X1, 8XA	1.4	103	4	05.10-	CAXA	0,8	SIZFR6B8EG	96209		
A1 1.4 TFSi COD	8X1, 8XA	1.4	103	4	04.12-	CPTA	0,8	PZKER7B8EGS	93231	55	
A1 1.4 TFSi COD	8XK, 8XF	1.4	110	4	11.14-	CZEA	0,8	PZKER7B8EGS	93231	55	
A1 1.4 TFSi	8X1, 8XA	1.4	136	4	11.10-	CAVG	0,8	SIZFR6B8EG	96209		
A1 1.4 TFSi	8X1	1.4	136	4	01.11-02.11	CAVG	0,9	PZFR6R	5758	52	
A1 S1 2.0 TFSi	8XK, 8XF	2.0	170	4	01.14-	CWZA	0,8	PLFER7A8EG	94833		
A1 quattro 2.0 TFSi	8X1	2.0	188	4	03.12-11.12	CDLH	0,8	PFR7S8EG	1675	50	PFR8S8EG

A1 (GBA)

A1 Sportback 1.0 25 TFSi	GBA	1.0	70	3	11.18-	DKLA	0,8	PKER7A8EGS	95463		
A1 40 2.0 TFSi (For OE-No. 06K905601L; Euro 6)	GBA	2.0	147	4	09.18-	CZPC, DKZC	0,8	ILFER7C8EG	91898		

A1 (GBA/GBH)

A1 30 1.0 TFSi	GBA, GBH	1.0	85	3	07.18-	DKJA, DKRF	0,8	IKER7A8EGS	94224		
A1 35 TFSi	GBA	1.5	110	4	09.18-	DADA	0,8	ILKER7A8EGS	95929		
A1 35 TFSi	GBA, GBH	1.5	110	4	09.18-	DPCA	0,8	ILKER7A8EGS	95929		
A1 City Carver 1.0 25 TFSi	GBH	1.0	70	3	07.19-	DKLA	0,8	PKER7A8EGS	95463		

A2 (8Z0)

A2 1.4	8Z0	1.4	55	4	06.00-04.02	AUA	1,0	BKUR6ET-10	2397	24	LPG 1
A2 1.4	8Z0	1.4	55	4	05.02-08.05	BBY	1,0	BKUR6ET-10	2397	24	LPG 1
A2 1.6 FSI	8Z0	1.6	81	4	05.02-08.05	BAD	0,5	ZFR6S-Q	6449		

A3 1 (8L1)

A3 1.6	8L1	1.6	74	4	09.96-06.01	AEH	1,0	BKUR6ET-10	2397	24	LPG 1
A3 1.6	8L1	1.6	74	4	08.97-06.03	AKL	1,0	BKUR6ET-10	2397	24	LPG 1
A3 1.6	8L1	1.6	74	4	06.99-08.00	APF	1,0	BKUR6ET-10	2397	24	LPG 1
A3 1.6	8L1	1.6	75	4	05.00-04.02	AVU	1,0	BKUR6ET-10	2397	24	LPG 1
A3 1.6	8L1	1.6	75	4	05.02-06.03	BFQ	1,0	BKUR6ET-10	2397	24	LPG 1
A3 1.8	8L1	1.8	92	4	09.96-08.00	AGN	1,0	BKUR6ET-10	2397	24	LPG 1
A3 1.8	8L1	1.8	92	4	11.99-06.03	APG	1,0	BKUR6ET-10	2397	24	LPG 1
A3 1.8 T	8L1	1.8	110	4	12.96-06.03	AGU	0,8	PFR6Q	6458	37	LPG 1
A3 1.8 T	8L1	1.8	110	4	08.98-04.01	AQA	0,8	PFR6Q	6458	37	LPG 1
A3 1.8 T	8L1	1.8	110	4	07.99-04.00	ARZ	0,8	PFR6Q	6458	37	LPG 1
A3 1.8 T	8L1	1.8	110	4	05.00-06.03	AUM	0,8	PFR6Q	6458	37	LPG 1
A3 1.8 T	8L1	1.8	110	4	09.00-06.03	ARX	0,8	PFR6Q	6458	37	LPG 1
A3 1.8 T	8L1	1.8	132	4	11.98-08.00	AJQ	0,8	PFR6Q	6458	37	LPG 1
A3 1.8 T	8L1	1.8	132	4	07.99-05.00	APP	0,8	PFR6Q	6458	37	LPG 1
A3 1.8 T	8L1	1.8	132	4	05.00-06.03	AUQ	0,8	PFR6Q	6458	37	LPG 1
A3 1.8 T	8L1	1.8	132	4	09.00-06.03	ARY	0,8	PFR6Q	6458	37	LPG 1
A3 S3 1.8 quattro	8L1	1.8	154	4	11.98-08.00	APY	0,8	PFR6Q	6458	37	LPG 1
A3 S3 1.8 quattro	8L1	1.8	154	4	09.99-04.01	AUL	0,8	PFR6Q	6458	37	LPG 1
A3 S3 1.8 quattro	8L1	1.8	154	4	09.00-04.02	AMK	0,8	PFR6Q	6458	37	LPG 1
A3 S3 1.8 quattro	8L1	1.8	165	4	08.01-06.03	BAM	0,8	PFR6Q	6458	37	LPG 1





l kW C
Y I



Stock-N°

VLINE

LPG/CNG

AUDI

A3 2 (8P1/8PA/8P7)

A3 1.2 TFSI	8P1, 8PA	1.2	77	4	03.10-08.12	CBZB	0,7	IZFR6P7	97153		
A3 1.4 TFSI	8P1, 8PA, 8P7	1.4	92	4	09.07-05.13	CAXC	0,9	PZFR6R	5758	52	
A3 1.4 TFSI	8P1, 8PA	1.4	92	4	05.10-08.12	CMSA	0,9	PZFR6R	5758	52	
A3 1.6	8P1, 8PA	1.6	75	4	05.03-05.05	BGU	1,0	BKUR6ET-10	2397	24	LPG 1
A3 1.6	8P1, 8PA	1.6	75	4	06.05-08.12	BSE, BSF	1,0	BKUR6ET-10	2397	24	LPG 1
A3 1.6	8P1, 8PA	1.6	75	4	07.08-08.12	CCSA	1,0	BKUR6ET-10	2397	24	LPG 1
A3 1.6 FlexFuel	8P1, 8PA	1.6	75	4	07.08-03.13	CMXA	1,0	BKUR6ET-10	2397	24	LPG 1
A3 1.6 Flexfuel	8P1	1.6	75	4	07.08-08.12	CCSA, CMXA	1,0	BKUR6ET-10	2397	24	LPG 1
A3 Sportback 1.6 Flexfuel	8PA	1.6	75	4	07.08-03.13	CCSA, CMXA	1,0	BKUR6ET-10	2397	24	LPG 1
A3 1.6	8P7	1.6	75	4	09.08-05.10	BSE	1,0	BKUR6ET-10	2397	24	LPG 1
A3 Cabrio 1.6	8P7	1.6	75	4	09.08-05.10	BSE	1,0	BKUR6ET-10	2397	24	LPG 1
A3 1.6	8P1, 8PA	1.6	75	4	05.10-08.12	CMXA	1,0	BKUR6ET-10	2397	24	LPG 1
A3 1.6 FSI	8P1	1.6	85	4	08.03-05.04	BAG	0,5	ZFR6S-Q	6449		
A3 1.6 FSI	8P1, 8PA	1.6	85	4	06.04-12.04	BLP	0,5	ZFR6S-Q	6449		
A3 1.6 FSI	8P1, 8PA	1.6	85	4	01.05-05.07	BLF	0,5	ZFR6S-Q	6449		
A3 1.8 TFSI	8P1, 8PA	1.8	118	4	01.07-05.07	BYT	0,8	PFR7S8EG	1675	50	PFR8S8EG
A3 1.8 TFSI	8P1, 8PA	1.8	118	4	06.07-05.08	BZB	0,8	PFR7S8EG	1675	50	PFR8S8EG
A3 1.8 TFSI	8P1, 8PA	1.8	118	4	07.08-08.12	CDAA	0,8	PFR7S8EG	1675	50	PFR8S8EG
A3 2.0 FSI	8P1	2.0	110	4	05.03-05.04	AXW	1,1	PZFR5N-11T	7742		
A3 2.0 FSI	8P1, 8PA	2.0	110	4	01.04-01.05	BMB	1,1	PZFR5N-11T	7742		
A3 2.0 FSI	8P1, 8PA	2.0	110	4	06.04-11.05	BLY	1,1	PZFR5N-11T	7742		
A3 2.0 FSI	8P1, 8PA	2.0	110	4	06.04-01.05	BLX	1,1	PZFR5N-11T	7742		
A3 2.0 FSI	8P1, 8PA	2.0	110	4	01.05-11.05	BLR	1,1	PZFR5N-11T	7742		
A3 2.0 FSI	8P1, 8PA	2.0	110	4	11.05-06.08	BVZ	1,1	PZFR5N-11T	7742		
A3 2.0 FSI	8P1, 8PA	2.0	110	4	11.05-01.07	BVY	1,1	PZFR5N-11T	7742		
A3 2.0 TFSI	8P1, 8PA	2.0	147	4	09.04-10.05	AXX	0,8	PFR7S8EG	1675	50	PFR8S8EG
A3 2.0 TFSI	8P1, 8PA	2.0	147	4	09.05-08.12	BWA	0,8	PFR7S8EG	1675	50	PFR8S8EG
A3 2.0 TFSI	8P1, 8PA	2.0	147	4	02.08-01.09	CAWB	0,8	PFR7S8EG	1675	50	PFR8S8EG
A3 2.0 TFSI	8P1, 8PA	2.0	147	4	07.08-08.12	CBFA, CCZA	0,8	PFR7S8EG	1675	50	PFR8S8EG
A3 S3 2.0 quattro	8P1	2.0	188	4	02.07-08.12	BZC	0,8	PFR7S8EG	1675	50	PFR8S8EG
A3 S3 2.0	8P1, 8PA	2.0	188	4	07.08-08.12	CDLC	0,8	PFR7S8EG	1675	50	PFR8S8EG
A3 S3 2.0	8P1, 8PA	2.0	195	4	11.06-05.07	BHZ	0,8	PFR7S8EG	1675	50	PFR8S8EG
A3 S3 2.0	8P1, 8PA	2.0	195	4	07.08-08.12	CDLA	0,8	PFR7S8EG	1675	50	PFR8S8EG
A3 3.2 quattro	8P1	3.2	184	6	07.03-08.04	BDB	0,9	IZKR7B	7563		
A3 3.2 quattro	8P1, 8PA	3.2	184	6	09.04-10.05	BMJ	0,9	IZKR7B	7563		
A3 3.2 quattro	8P1, 8PA	3.2	184	6	11.05-05.09	BUB	0,9	IZKR7B	7563		

A3 3 (8V1/8VA)

A3 1.2 TFSI	8V1, 8VA	1.2	77	4	09.12-	CJZA	0,8	PZKER7B8EGS	93231	55	
A3 1.2 TFSI	8V1, 8VA	1.2	81	4	05.14-	CYVB	0,8	PZKER7B8EGS	93231	55	
A3 1.4 TFSI	8V1, 8VA	1.4	90	4	04.12-	CMBA	0,8	PZKER7B8EGS	93231	55	

A3 3 (8V1/8VA/8VS)

A3 1.4 TFSI	8V1, 8VA, 8VS	1.4	90	4	04.12-	CXSA	0,8	PZKER7B8EGS	93231	55	
A3 1.4 TFSI	8V1, 8VA, 8VS, 8V7	1.4	92	4	09.13-	CXSB, CZCA	0,8	PZKER7B8EGS	93231	55	
A3 1.4 TFSI COD	8V1, 8VA, 8VS, 8V7	1.4	103	4	10.12-	CPTA	0,8	PZKER7B8EGS	93231	55	





kW
C
Y
I



Stock-N°

VLINE

LPG/CNG

AUDI

A3 3 (8V1/8VA/8VS)

A3 1.4 TFSI COD	8V1, 8VA, 8VS, 8V7	1.4	110	4	05.14-	CZEA	0,8	PZKER7B8EGS	93231	55	
-----------------	--------------------	-----	-----	---	--------	------	-----	-------------	-------	----	--

A3 3 (8VA)

A3 1.4 TFSI e-tron Hybrid	8VA	1.4	110	4	05.14-	CUKB	0,8	PZKER7B8EGS	93231	55	
---------------------------	-----	-----	-----	---	--------	------	-----	-------------	-------	----	--

A3 3 (8VE/8VK)

A3 1.0 TFSi	8VK	1.0	85	3	07.16-	CHZD	0,8	IKER7A8EGS	94224		
A3 35 TFSi/TFSi	8VE, 8VK	1.5	110	4	05.17-	DADA	0,8	ILKER7A8EGS	95929		
A3 35 TFSi/TFSi	8VE	1.5	110	4	05.17-	DPCA	0,8	ILKER7A8EGS	95929		
A3 Cabrio Quattro 2.0 40 TFSi/TFSi	8VE	2.0	140	4	05.16-	DKZA	0,8	PLFER7A8EG	94833		
S3 2.0 TFSi	8VK	2.0	213	4	07.16-	CJXD, DJHB	0,8	ILFER7C8EG	91898		
S3 2.0 TFSi (For OE-No. 06K905601L)	8VE, 8VK	2.0	228	4	06.16-	DJHA	0,8	ILFER7C8EG	91898		

A3 3 (8VM/8VF)

A3 30 TFSi/TFSi	8VF, 8VM	1.0	85	3	07.16-	CHZD, DKRF	0,8	IKER7A8EGS	94224		
A3 30 g-tron	8VF	1.5	96	4	11.18-	DHFA	0,8	ILKER7B8DES	90560		
A3 35 TFSi/TFSi/TFSi ACT	8VM, 8VF	1.5	110	4	05.17-	DADA, DPCA	0,8	ILKER7A8EGS	95929		
A3 Sportback Quattro 2.0 40 TFSi/TFSi (Euro 6)	8VF	2.0	140	4	05.16-	DKZA	0,8	PLFER7A8EG	94833		
A3 Quattro 2.0 40 TFSi/TFSi (Euro 6)	8VM	2.0	140	4	05.16-	DKZA	0,8	PLFER7A8EG	94833		
S3 2.0 TFSi	8VF, 8VM	2.0	213	4	07.16-	CJXD, DJHB	0,8	ILFER7C8EG	91898		
S3 2.0 TFSi (For OE-No. 06K905601L)	8VF, 8VM	2.0	228	4	06.16-	DJHA	0,8	ILFER7C8EG	91898		
RS3 2.5 TFSi quattro, quattro Sportback	8VM, 8VF	2.5	294	5	04.17-	DAZA	0,7	SILFER8C7ES	91006		

A3 4 (8YA/8YS)

A3 40 TFSIe	8YA	1.4	110	4	06.20-	DGEA	0,8	ILKER7A8EGS	95929		
A3 30 g-tron	8YA	1.5	96	4	07.20-	DHFA	0,8	ILKER7B8DES	90560		
A3 35 TFSi	8YA, 8YS	1.5	110	4	11.19-	DPCA	0,8	ILKER7A8EGS	95929		
A3 35 TFSi Mild Hybrid	8YA, 8YS	1.5	110	4	04.20-	DFYA	0,8	ILKER7A8EGS	95929		

A4 1 (8D2/8D5 B5)

A4 1.6	8D2, 8D5 B5	1.6	74	4	11.94-10.96	ADP	1,0	BKUR6ET-10	2397	24	LPG 1
A4 1.6	8D2, 8D5 B5	1.6	74	4	10.96-07.99	AHL	1,0	BKUR6ET-10	2397	24	LPG 1
A4 1.6	8D2, 8D5 B5	1.6	74	4	08.98-06.00	ANA	1,0	BKUR6ET-10	2397	24	LPG 1
A4 1.6	8D2, 8D5 B5	1.6	74	4	08.98-09.01	ARM	1,0	BKUR6ET-10	2397	24	LPG 1
A4 1.6	8D2, 8D5 B5	1.6	75	4	07.00-11.00	ALZ	1,0	BKUR6ET-10	2397	24	LPG 1
A4 1.8	8D2, 8D5 B5	1.8	85	4	07.95-12.98	AFY	1,0	BKUR6ET-10	2397	24	LPG 1
A4 1.8	8D2, 8D5 B5	1.8	92	4	11.94-04.99	ADR	1,0	BKUR6ET-10	2397	24	LPG 1
A4 1.8	8D2, 8D5 B5	1.8	92	4	07.98-09.01	ARG	1,0	BKUR6ET-10	2397	24	LPG 1
A4 1.8	8D2, 8D5 B5	1.8	92	4	02.99-09.01	APT	1,0	BKUR6ET-10	2397	24	LPG 1
A4 1.8	8D2, 8D5 B5	1.8	92	4	06.00-09.01	AVV	1,0	BKUR6ET-10	2397	24	LPG 1
A4 1.8 T	8D2, 8D5 B5	1.8	110	4	01.96-12.98	AEB	0,8	PFR6Q	6458	37	LPG 1
A4 1.8 T	8D2, 8D5 B5	1.8	110	4	07.98-07.99	ARK	0,8	PFR6Q	6458	37	LPG 1
A4 1.8 T	8D2, 8D5 B5	1.8	110	4	08.98-09.01	APU	0,8	PFR6Q	6458	37	LPG 1
A4 1.8 T	8D2, 8D5 B5	1.8	110	4	05.99-06.00	ANB	0,8	PFR6Q	6458	37	LPG 1
A4 1.8 T (For USA)	8D2, 8D5 B5	1.8	110	4	08.99-05.00	ATW	0,8	PFR6Q	6458	37	LPG 1
A4 1.8 T	8D2, 8D5 B5	1.8	110	4	06.00-09.01	AWT	0,8	PFR6Q	6458	37	LPG 1
A4 1.8 T	8D2, 8D5 B5	1.8	132	4	08.97-09.01	AJL	0,8	PFR6Q	6458	37	LPG 1
A4 2.4 V6 China	8D2, 8D5 B5	2.4	110	6	07.95-07.97	AFM	1,0	BKUR6ET-10	2397	24	LPG 1
A4 2.4 V6	8D2, 8D5 B5	2.4	120	6	08.97-07.98	AJG	0,5	BKR6EKUB	3584		LPG 1





l kW C
Y
I



Stock-N°

VLINE

LPG/CNG

AUDI

A4 1 (8D2/8D5 B5)

A4 2.4 V6	8D2, 8D5 B5	2.4	120	6	08.97-11.00	AMM	0,5	BKR6EKUB	3584		LPG 1
A4 2.4 V6	8D2, 8D5 B5	2.4	120	6	08.98-06.00	APZ	0,5	BKR6EKUB	3584		LPG 1
A4 2.4 V6	8D2, 8D5 B5	2.4	121	6	08.97-07.98	AGA, ALF	0,5	BKR6EKUB	3584		LPG 1
A4 2.4 V6	8D2, 8D5 B5	2.4	121	6	08.98-09.01	AML	0,5	BKR6EKUB	3584		LPG 1
A4 2.4 V6	8D2, 8D5 B5	2.4	121	6	08.98-06.00	ARJ	0,5	BKR6EKUB	3584		LPG 1
A4 2.4 V6 China	8D2, 8D5 B5	2.4	121	6	08.98-09.01	APS	0,5	BKR6EKUB	3584		LPG 1
A4 2.6 V6 China / GUS	8D2, 8D5 B5	2.6	102	6	06.94-10.97	ACZ	1,0	BKUR6ET-10	2397	24	LPG 1
A4 2.6	8D2 B5	2.6	102	6	01.96-07.97	ACZ	1,0	BKUR6ET-10	2397	24	LPG 1
A4 2.6 V6	8D2, 8D5 B5	2.6	110	6	11.94-07.97	ABC	1,0	BKUR6ET-10	2397	24	LPG 1
A4 S4 quattro	8D2, 8D5 B5	2.7	169	6	07.98-08.00	AJK	0,8	PFR6Q	6458	37	LPG 1
A4 S4 quattro	8D2, 8D5 B5	2.7	184	6	07.98-12.98	APB	0,8	PFR6Q	6458	37	LPG 1
A4 S4 quattro	8D2, 8D5 B5	2.7	195	6	10.97-09.01	AGB	0,8	PFR6Q	6458	37	LPG 1
A4 S4 quattro	8D2, 8D5 B5	2.7	195	6	11.00-09.01	AZB	0,8	PFR6Q	6458	37	LPG 1
A4 avant RS4 quattro	8D5 B5	2.7	280	6	06.00-10.00	ASJ	0,8	PFR7Q	7963		
A4 avant RS4 quattro	8D5 B5	2.7	280	6	11.00-09.01	AZR	0,8	PFR7Q	7963		
A4 2.8 V6 (For USA)	8D2, 8D5 B5	2.8	128	6	08.94-07.98	AFC	1,0	BKUR6ET-10	2397	24	LPG 1
A4 2.8 V6	8D2, 8D5 B5	2.8	128	6	11.94-07.97	AAH	1,0	BKUR6ET-10	2397	24	LPG 1
A4 2.8 V6 China, SA	8D2, 8D5 B5	2.8	140	6	03.99-09.01	ATX	0,5	BKR6EKUB	3584		LPG 1
A4 2.8	8D2 B5	2.8	140	6	09.99-10.00	ATX	0,5	BKR6EKUB	3584		LPG 1
A4 Quattro 2.8	8D2 B5	2.8	140	6	09.99-10.00	ATX	0,5	BKR6EKUB	3584		LPG 1
A4 2.8 V6	8D2, 8D5 B5	2.8	142	6	03.96-07.98	ACK	0,5	BKR6EKUB	3584		LPG 1
A4 2.8 V6	8D2, 8D5 B5	2.8	142	6	05.97-07.98	ALG	0,5	BKR6EKUB	3584		LPG 1
A4 2.8 V6	8D2, 8D5 B5	2.8	142	6	07.98-09.01	AMX	0,5	BKR6EKUB	3584		LPG 1
A4 2.8 V6	8D2, 8D5 B5	2.8	142	6	08.98-06.00	APR, AQD	0,5	BKR6EKUB	3584		LPG 1

A4 2 (8E2/8E5 B6)

A4 1.6	8E2, 8E5	1.6	75	4	11.00-11.04	ALZ	1,0	BKUR6ET-10	2397	24	LPG 1
A4 1.8 T	8E2, 8E5	1.8	110	4	12.00-06.02	AWJ	0,8	PFR6Q	6458	37	LPG 1
A4 1.8 T	8E2, 8E5	1.8	120	4	07.02-11.04	BFB	0,8	PFR6Q	6458	37	LPG 1
A4 1.8 T	8E2, 8E5	1.8	120	4	07.02-12.04	BKB	0,8	PFR6Q	6458	37	LPG 1
A4 Quattro 1.8	8E2 B6	1.8	125	4	07.01-12.04	AMB	0,8	PFR6Q	6458	37	LPG 1
A4 1.8 T	8E2, 8E5	1.8	140	4	11.02-12.04	BEX	0,8	PFR6Q	6458	37	LPG 1
A4 2.0	8E2, 8E5	2.0	96	4	12.00-11.04	ALT	1,0	BKUR5ET-10	7553		LPG 1
A4 2.0 FSI	8E2, 8E5	2.0	110	4	07.02-12.04	AWA	1,1	PZFR5N-11T	7742		
A4 2.4 V6	8E2, 8E5	2.4	120	6	09.01-12.04	AMM	0,5	BKR6EKUB	3584		LPG 1
A4 2.4 V6	8E2, 8E5	2.4	125	6	09.01-12.04	BDV	0,5	BKR6EKUB	3584		LPG 1
A4 3.0 V6	8E2, 8E5	3.0	160	6	04.01-10.04	BBJ	0,5	BKR6EKUB	3584		LPG 1
A4 3.0 V6	8E2, 8E5	3.0	162	6	12.00-12.05	ASN	0,5	BKR6EKUB	3584		LPG 1
A4 Quattro 3.0	8E5 B6	3.0	162	6	06.01-10.04	AVK	1,1	PFR6U-11G	5874		
A4 3.0 V6	8E2, 8E5	3.0	162	6	09.01-06.02	AVK	1,1	PFR6U-11G	5874		
A4 S4 4.2 quattro	8E2, 8E5	4.2	253	8	03.03-10.04	BBK	0,5	BKR6EQUA	6872		LPG 1

A4 3 (8EC/8ED)

A4 1.6	8EC, 8ED	1.6	75	4	11.04-	ALZ	1,0	BKUR6ET-10	2397	24	LPG 1
A4 1.8 T	8EC, 8ED	1.8	120	4	11.04-	BFB	0,8	PFR6Q	6458	37	LPG 1
A4 2.0	8EC, 8ED	2.0	96	4	11.04-	ALT	1,0	BKUR5ET-10	7553		LPG 1
A4 2.0 TFSI	8EC, 8ED	2.0	125	4	10.06-	BYK	0,8	PFR7S8EG	1675	50	PFR8S8EG





kw CYI



Stock-No

VLINE

LPG/CNG

AUDI

A4 3 (8EC/8ED)

A4 2.0 TFSI	8EC, 8ED	2.0	125	4	03.07-	BRJ	0,8	PFR7S8EG	1675	50	PFR8S8EG
A4 2.0 TFSI	8EC, 8ED	2.0	147	4	11.04-03.08	BGB	0,8	PFR7S8EG	1675	50	PFR8S8EG
A4 2.0 TFSI	8EC, 8ED	2.0	147	4	09.05-	BWE	0,8	PFR7S8EG	1675	50	PFR8S8EG
A4 2.0 TFSI	8EC, 8ED	2.0	162	4	06.05-	BUL	0,8	PFR7S8EG	1675	50	PFR8S8EG
A4 3.0 V6	8EC, 8ED	3.0	160	6	11.04-07.06	BBJ	0,5	BKR6EKUB	3584		LPG 1
A4 Quattro 3.0	8ED B7	3.0	160	6	11.04-07.06	BBJ	0,5	BKR6EKUB	3584		LPG 1
A4 3.2 FSI	8EC, 8ED	3.2	188	6	01.05-	AUK	0,9	PFR7W-T	6840		
A4 S4 4.2 quattro	8EC, 8ED	4.2	253	8	11.04-	BBK	0,5	BKR6EQUA	6872		LPG 1
A4 S4 4.2 quattro	8EC, 8ED	4.2	253	8	03.06-	BHF	0,5	BKR6EQUA	6872		LPG 1
RS4 Quattro 4.2	8EC B7	4.2	309	8	04.05-12.08	BNS	0,9	PFR7W-TG	5592		
A4 RS4 quattro	8EC, 8ED	4.2	309	8	11.05-	BNS	0,9	PFR7W-TG	5592		

A4 3 (8H7)

A4 Cabrio 3.0	8H7 B6	3.0	160	6	04.02-12.05	BBJ	0,5	BKR6EKUB	3584		LPG 1
---------------	--------	-----	-----	---	-------------	-----	-----	----------	------	--	-------

A4 3 (8HE)

RS4 Cabrio Quattro 4.2	8HE B7	4.2	309	8	02.06-12.08	BNS	0,9	PFR7W-TG	5592		
------------------------	--------	-----	-----	---	-------------	-----	-----	----------	------	--	--

A4 4 (8K2/8K5)

A4 1.8 TFSI	8K2, 8K5	1.8	88	4	01.08-05.08	CABA	0,8	PFR7S8EG	1675	50	PFR8S8EG
A4 1.8 TFSI	8K2, 8K5	1.8	88	4	06.08-	CDHA	0,8	PFR7S8EG	1675	50	PFR8S8EG
A4 1.8 TFSI	8K2, 8K5	1.8	118	4	11.07-05.08	CABB	0,8	PFR7S8EG	1675	50	PFR8S8EG
A4 1.8 TFSI	8K2, 8K5	1.8	118	4	06.08-	CDHB	0,8	PFR7S8EG	1675	50	PFR8S8EG
A4 2.0 TFSI	8K2, 8K5	2.0	132	4	06.08-	CAEA, CDNB	0,8	PFR7S8EG	1675	50	PFR8S8EG
A4 2.0 TFSI flexible fuel	8K2, 8K5	2.0	132	4	11.09-	CFKA	0,8	PFR7S8EG	1675	50	PFR8S8EG
A4 2.0 TFSI	8K2, 8K5	2.0	155	4	06.08-	CDNC	0,8	PFR7S8EG	1675	50	PFR8S8EG
A4 2.0 TFSi	8K2 B8	2.0	162	4	05.13-12.15	CAED	0,8	PFR7S8EG	1675	50	PFR8S8EG
A4 3.0 TFSi	8K2, 8K5	3.0	200	6	02.12-12.15	CMUA, CRED	0,8	PFR8S8EG	94460		
A4 S4 3.0 quattro	8K2, 8K5	3.0	245	6	03.09-	CAKA, CCBA	0,8	PFR8S8EG	94460		
A4 3.2 FSI	8K2, 8K5	3.2	195	6	11.07-	CALA	1,1	PFR6X-11	5757		

A4 5 (8W)

A4 1.4 TFSi	8W2	1.4	110	4	08.15-	CVNA	0,8	PKER7A8EGS	95463		
A4 1.4 TFSi	8W5	1.4	110	4	02.16-	CVNA	0,8	PKER7A8EGS	95463		
A4 35 TFSi Mild Hybrid	8W2, 8W5	2.0	110	4	12.18-	DLVB	0,8	ILFER7C8EG	91898		
A4 45 TFSi Mild Hybrid (For OE-No. 06K905601L)	8W2, 8W5	2.0	180	4	07.18-	DKNA	0,8	ILFER7C8EG	91898		
A4 45 TFSi (For OE-No. 06K905601L)	8WH	2.0	180	4	07.18-	DKNA	0,8	ILFER7C8EG	91898		
A4 2.0 TFSi Mild Hybrid (For OE-No. 06K905601L)	8W2, 8W5, 8WH	2.0	185	4	05.17-	DDWA	0,8	ILFER7C8EG	91898		
A4 Allroad Quattro 2.0 TFSi Mild Hybrid	8WH B9	2.0	185	4	11.18-10.19	DDWA	0,8	PLFER7A8EG	94833		
RS4 2.9 TFSi	8W5	2.9	331	6	09.17-09.19	DECA	0,7	SILKGR9A7ES	93560		
S4 3.0 TFSi	8W2, 8W5	3.0	260	6	05.16-11.19	CWGD	0,7	SILKGR9A7ES	93560		

A5

A5 1.8 TFSI	8T3, 8F7, 8TA	1.8	118	4	05.09-03.12	CDHB	0,8	PFR7S8EG	1675	50	PFR8S8EG
A5 1.8 TFSI	8T3, 8F7, 8TA	1.8	125	4	10.07-11.08	CABD	0,8	PFR7S8EG	1675	50	PFR8S8EG
A5 35 TFSi Mild Hybrid	F53, F5A	2.0	110	4	08.18-	DLVB	0,8	ILFER7C8EG	91898		
A5 2.0 TFSI	8T3, 8F7, 8TA	2.0	132	4	09.08-06.14	CDNB	0,8	PFR7S8EG	1675	50	PFR8S8EG
A5 2.0 TFSI	8T3, 8F7, 8TA	2.0	132	4	03.09-03.12	CAEA	0,8	PFR7S8EG	1675	50	PFR8S8EG





l kW C
Y
I



Stock-N°

VLINE

LPG/CNG

AUDI

A5

A5 2.0 TFSI	8T3, 8F7, 8TA	2.0	155	4	06.08-06.14	CAEB, CDNC	0,8	PFR7S8EG	1675	50	PFR8S8EG
A5 2.0 TFSI	8TA	2.0	155	4	09.09-05.13	CDNC	0,8	PFR7S8EG	94976	50	PFR8S8EG
A5 45 TFSi Mild Hybrid (For OE-No. 06K905601L; Euro 6)	F53, F57, F5A	2.0	180	4	07.18-	DKNA	0,8	ILFER7C8EG	91898		
A5 2.0 TFSi Mild Hybrid (For OE-No. 06K905601L)	F53, F57, F5A	2.0	185	4	05.17-	DDWA, DLHB	0,8	ILFER7C8EG	91898		
RS5 2.9 TFSI	F53, F5P, F5A, F5F	2.9	331	6	04.17-	DECA	0,7	SILKGR9A7ES	93560		
A5 3.0 V6 TFSI quattro	8T3, 8F7, 8TA	3.0	200	6	11.11-	CMUA	0,8	PFR8S8EG	94460		
A5 S5 3.0 FSI quattro	8T3, 8F7, 8TA	3.0	245	6	05.09-	CGWC	0,8	PFR8S8EG	94460		
A5 S5 Coupe/Sportback 3.0 FSI quattro	8T3, 8TA	3.0	245	6	06.09-	CAKA	0,8	PFR8S8EG	94460		
A5 S5 3.0 FSI quattro	8T3	3.0	245	6	10.11-	CGXC	0,8	PFR8S8EG	94460		
S5 3.0 TFSI	F5A, F53, F57, F5E	3.0	260	6	07.16-	CWGD	0,7	SILKGR9A7ES	93560		
A5 3.2 FSI	8T3, 8F7, 8TA	3.2	195	6	06.07-03.12	CALA	1,1	PFR6X-11	5757		
A5 S5 4.2 FSI quattro	8T3	4.2	260	8	06.07-02.12	CAUA	0,9	PFR6W-TG	5547		
A5 RS5 4.2 FSI quattro	8T3	4.2	331	8	03.10-	CFSA	0,8	PFR7S8EG	1675	50	PFR8S8EG
A5 2.0 TFSI	8F7	2.0	165	4	05.13-05.16	CNCD	0,8	PLFER7A8EG	94833		
A5 S5 Cabriolet 3.0 FSI quattro	8F7	3.0	245	6	05.09-	CCBA	1,1	PFR6X-11	5757		
S5 Cabrio Quattro 3.0 TFSI	8F7	3.0	245	6	05.09-01.17	CGWC	0,8	PFR8S8EG	94460		
A5 S5 Cabriolet 3.0 FSI quattro	8F7	3.0	245	6	06.09-	CAKA	1,1	PFR6X-11	5757		
RS5 Cabrio Quattro 4.2 FSI	8F7	4.2	331	8	11.12-08.15	CFSA	0,8	PFR7S8EG	1675	50	PFR8S8EG
A5 1.8 TFSI	8F7, 8TA	1.8	118	4	09.09-03.12	CDHB	0,8	PFR7S8EG	94976	50	PFR8S8EG
S5 3.0 TFSI	8F7, 8TA	3.0	245	6	05.09-01.17	CAKA, CCBA, CGWC	0,8	PFR7S8EG	94976	50	PFR8S8EG

A6

A6		2.0	79	4	06.96-10.97	ADW	0,8	BUR6ET	3172	1	LPG 2
A6 China		2.4	110	6	07.95-10.97	AFM	1,0	BKUR6ET-10	2397	24	LPG 1
A6 China / GUS		2.6	102	6	06.94-10.97	ACZ	1,0	BKUR6ET-10	2397	24	LPG 1
A6 biturbo (For USA)		2.7	187	6	05.99-06.02	APB	0,8	PFR6Q	6458	37	LPG 1
A6 3.2 FSI		3.2	195	6	05.09-	CALA	1,1	PFR6X-11	5757		

A6 1 (4A/C4)

A6 1.8	4A, C4	1.8	92	4	10.95-10.97	ADR	1,0	BKUR6ET-10	2397	24	LPG 1
A6 2.0	4A, C4	2.0	74	4	06.94-06.96	AAE	0,8	BUR6ET	3172	1	LPG 2
A6 2.0	4A2 C4	2.0	79	4	06.94-10.97	ADW	0,8	BUR6ET	3172	1	LPG 2
A6 2.0 E	4A, C4	2.0	85	4	06.94-06.96	ABK	0,8	BUR6ET	3172	1	LPG 2
A6 2.0 16V	4A, C4	2.0	103	4	06.94-10.97	ACE	0,8	BKUR7ET	7873		
A6 S6	4A, C4	2.2	169	5	06.94-07.97	AAN	0,6	PFR7B	4853		
A6 2.3 E	4A, C4	2.3	98	5	06.94-06.96	AAR	0,7	BPR5EKU	5685		LPG 2
A6 2.6 E	4A, C4	2.6	110	6	06.94-10.97	ABC	1,0	BKUR6ET-10	2397	24	LPG 1
A6 2.8 E GUS	4A, C4	2.8	120	6	07.96-10.97	AEJ	0,8	PFR5B-9	2392		PFR6B
A6 2.8 E	4A, C4	2.8	128	6	06.94-10.97	AAH	1,0	BKUR6ET-10	2397	24	LPG 1
A6 2.8 E	4A, C4	2.8	128	6	08.94-06.95	AFC	1,0	BKUR6ET-10	2397	24	LPG 1
A6 2.8 E	4A, C4	2.8	142	6	10.95-07.98	ACK	0,5	BKR6EKUB	3584		LPG 1
A6 S6 4.2	4A, C4	4.2	213	8	09.94-10.97	AEC	0,8	BUR6EFSZ	6837		
A6 S6 Plus	4A, C4	4.2	240	8	06.96-10.97	AHK	0,8	BUR6EFSZ	6837		

A6 2 (4B/C5)

A6 1.8 GUS	4B, C5	1.8	85	4	05.97-05.00	AFY	1,0	BKUR6ET-10	2397	24	LPG 1
------------	--------	-----	----	---	-------------	-----	-----	------------	------	----	-------





l kW C
Y
I



Stock-N°

VLINE

LPG/CNG

AUDI

A6 2 (4B/C5)

A6 1.8	4B, C5	1.8	92	4	12.97-07.99	AJP	1,0	BKUR6ET-10	2397	24	LPG 1
A6 1.8	4B, C5	1.8	92	4	01.99-04.01	AQE, ARH	1,0	BKUR6ET-10	2397	24	LPG 1
A6 1.8 T	4B, C5	1.8	110	4	04.97-01.99	AEB	0,8	PFR6Q	6458	37	LPG 1
A6 1.8 T	4B, C5	1.8	110	4	11.98-05.01	APU	0,8	PFR6Q	6458	37	LPG 1
A6 1.8 T	4B, C5	1.8	110	4	01.99-05.01	ANB	0,8	PFR6Q	6458	37	LPG 1
A6 1.8 T	4B, C5	1.8	110	4	01.99-05.99	ARK	0,8	PFR6Q	6458	37	LPG 1
A6 1.8 T	4B, C5	1.8	110	4	05.00-01.05	AWT	0,8	PFR6Q	6458	37	LPG 1
A6 1.8 T	4B, C5	1.8	132	4	11.97-10.00	AJL	0,8	PFR6Q	6458	37	LPG 1
A6 2.0	4B, C5	2.0	96	4	06.01-01.05	ALT	1,0	BKUR5ET-10	7553		LPG 1
A6 2.4	4B, C5	2.4	99	6	08.97-01.99	ALW	0,5	BKR6EKUB	3584		LPG 1
A6 2.4	4B, C5	2.4	100	6	02.99-05.00	ARN	0,5	BKR6EKUB	3584		LPG 1
A6 2.4	4B, C5	2.4	100	6	06.00-01.05	ASM	0,5	BKR6EKUB	3584		LPG 1
A6 2.4	4B, C5	2.4	120	6	04.97-01.99	AJG	0,5	BKR6EKUB	3584		LPG 1
A6 2.4	4B, C5	2.4	120	6	11.98-05.01	APZ	0,5	BKR6EKUB	3584		LPG 1
A6 2.4	4B, C5	2.4	120	6	06.00-04.01	AMM	0,5	BKR6EKUB	3584		LPG 1
A6 2.4	4B, C5	2.4	121	6	04.97-01.99	AGA	0,5	BKR6EKUB	3584		LPG 1
A6 2.4	4B, C5	2.4	121	6	06.97-01.99	ALF	0,5	BKR6EKUB	3584		LPG 1
A6 2.4	4B, C5	2.4	121	6	04.98-05.01	APC	0,5	BKR6EKUB	3584		LPG 1
A6 2.4	4B, C5	2.4	121	6	11.98-05.01	ARJ	0,5	BKR6EKUB	3584		LPG 1
A6 2.4 China	4B, C5	2.4	121	6	11.98-05.01	APS	0,5	BKR6EKUB	3584		LPG 1
A6 2.4	4B, C5	2.4	121	6	06.00-05.01	AML	0,5	BKR6EKUB	3584		LPG 1
A6 2.4	4B, C5	2.4	125	6	06.01-01.05	BDV	0,5	BKR6EKUB	3584		LPG 1
A6 2.7 T	4B, C5	2.7	169	6	02.99-08.00	AJK	0,8	PFR6Q	6458	37	LPG 1
A6 2.7 T	4B, C5	2.7	169	6	09.00-05.01	AZA	0,8	PFR6Q	6458	37	LPG 1
A6 2.7 T	4B, C5	2.7	184	6	05.00-06.02	ARE	0,8	PFR6Q	6458	37	LPG 1
A6 2.7 T	4B, C5	2.7	184	6	07.02-08.05	BES	0,8	PFR6Q	6458	37	LPG 1
A6 2.8	4B, C5	2.8	132	6	02.98-05.01	AGE	0,5	BKR6EKUB	3584		LPG 1
A6 Quattro 2.8	4B2 C5	2.8	140	6	08.98-05.01	ATX	0,5	BKR6EKUB	3584		LPG 1
A6 2.8	4B, C5	2.8	140	6	07.99-05.01	ATX	0,5	BKR6EKUB	3584		LPG 1
A6 2.8	4B, C5	2.8	142	6	06.97-01.99	ALG	0,5	BKR6EKUB	3584		LPG 1
A6 2.8 (For USA)	4B, C5	2.8	142	6	08.97-07.99	AHA	0,5	BKR6EKUB	3584		LPG 1
A6 2.8	4B, C5	2.8	142	6	11.98-05.01	APR, AQD	0,5	BKR6EKUB	3584		LPG 1
A6 2.8	4B, C5	2.8	142	6	06.00-05.01	AMX	0,5	BKR6EKUB	3584		LPG 1
A6 3.0	4B5 C5	3.0	160	6	06.01-01.05	BBJ	0,5	BKR6EKUB	3584		LPG 1
A6 Quattro 3.0	4B5 C5	3.0	160	6	06.01-01.05	BBJ	0,5	BKR6EKUB	3584		LPG 1
A6 3.0	4B2 C5	3.0	160	6	06.01-01.05	BBJ	0,5	BKR6EKUB	3584		LPG 1
A6 Quattro 3.0	4B2 C5	3.0	160	6	06.01-01.05	BBJ	0,5	BKR6EKUB	3584		LPG 1
A6 3.0	4B, C5	3.0	162	6	06.01-01.05	ASN	0,5	BKR6EKUB	3584		LPG 1
A6 4.2 quattro	4B, C5	4.2	220	8	11.98-01.05	ARS, ASG	0,5	BKR6EQUA	6872		LPG 1
A6 4.2 allroad	4B, C5	4.2	220	8	04.03-08.05	BAS	0,5	BKR6EQUA	6872		LPG 1
A6 RS6 quattro	4B, C5	4.2	331	8	07.02-09.04	BCY	0,8	PFR7Q	7963		
A6 RS6 plus quattro	4B, C5	4.2	353	8	04.04-01.05	BRV	0,8	PFR7Q	7963		

A6 3 (4F2/4F5)

A6 2.0 TFSI	4F2, 4F5	2.0	125	4	06.05-	BPJ	0,8	PFR7S8EG	1675	50	PFR8S8EG
A6 2.4	4F2, 4F5	2.4	130	6	04.04-10.08	BDW	1,1	PFR6X-11	5757		





e kW C
Y
I



Stock-N°

VLINE

LPG/CNG

AUDI

A6 3 (4F2/4F5)

A6 2.8 FSI	4F2, 4F5	2.8	140	6	10.08-	CCDA	1,1	PFR6X-11	5757		
A6 2.8 FSI	4F2, 4F5	2.8	154	6	11.06-	BDX	1,1	PFR6X-11	5757		
A6 2.8 FSI	4F2, 4F5	2.8	162	6	10.08-	CCEA	1,1	PFR6X-11	5757		
A6 3.0 quattro	4F2, 4F5	3.0	160	6	06.01-05.06	BBJ	0,5	BKR6EKUB	3584		LPG 1
A6 3.0 TFSI	4F2, 4F5	3.0	213	6	10.08-	CAJA	0,8	PFR8S8EG	94460		
A6 3.0 TFSI quattro	4F2, 4F5	3.0	220	6	10.08-	CCAA	0,8	PFR8S8EG	94460		
A6 3.2 FSI quattro	4F2	3.2	183	6	09.06-10.08	BYU	0,9	PFR7W-T	6840		
A6 3.2 FSI	4F2, 4F5	3.2	188	6	04.04-	AUK	0,9	PFR7W-T	6840		
A6 3.2 FSI	4F2, 4F5	3.2	188	6	10.08-	BKH	1,1	PFR6X-11	5757		
A6 4.2 quattro	4F2, 4F5	4.2	246	8	04.04-05.06	BAT	0,5	BKR6EQUA	6872		LPG 1
A6 4.2 FSI quattro	4F2, 4F5	4.2	257	8	05.06-	BVJ	0,9	PFR6W-TG	5547		
A6 S6 quattro	4F2, 4F5	5.2	320	10	06.06-	BXA	0,9	PFR6W-TG	5547		

A6 4 (4B6/4B4)

A6 4.2 S6 quattro	4B6, 4B4	4.2	250	8	09.99-01.05	ANK, AQJ	0,7	BKR6EQUP	3199	30	LPG 1
-------------------	----------	-----	-----	---	-------------	----------	-----	----------	------	----	-------

A6 4 (4G2/4G5)

A6 2.0 TFSI	4G2, 4G5	2.0	132	4	05.11-	CDNB	0,8	PFR7S8EG	1675	50	PFR8S8EG
A6 2.0 TFSI	4G2, 4G5	2.0	155	4	03.11-	CAEB	0,8	PFR7S8EG	1675	50	PFR8S8EG
A6 2.0 TFSI Hybrid	4G2, 4G5	2.0	155	4	11.11-	CHJA	0,8	PFR7S8EG	1675	50	PFR8S8EG
A6 3.0 TFSI quattro	4G2, 4G5	3.0	220	6	04.11-	CGWB	0,8	PFR8S8EG	94460		
A6 3.0 TFSI quattro	4G2, 4G5	3.0	228	6	03.11-	CGWD, CGXB, CTUA	0,8	PFR8S8EG	94460		

A6 4 (4GC/4GD)

A6 2.0 TFSi	4GC, 4GD	2.0	185	4	09.14-	CYNB, CYPA	0,8	PLFER7A8EG	94833		
A6 3.0 TFSi quattro	4GC, 4GD	3.0	245	6	09.14-	CREC	0,8	PFR8S8EG	94460		

A6 4 (4GD)

A6 1.8 TFSi	4GD	1.8	140	4	09.14-	CYGA	0,8	PLFER7A8EG	94833		
-------------	-----	-----	-----	---	--------	------	-----	------------	-------	--	--

A6 4 (4GJ)

A6 3.0 TFSi Allroad	4GJ	3.0	245	6	09.14-	CREC	0,8	PFR8S8EG	94460		
---------------------	-----	-----	-----	---	--------	------	-----	----------	-------	--	--

A6 5 (4A)

A6 55 TFSi Mild Hybrid	4A2, 4A5, 4AH	3.0	250	6	02.18-	DLZA	0,7	SILKGR9A7ES	93560		
------------------------	---------------	-----	-----	---	--------	------	-----	-------------	-------	--	--

A6 5 (4A2/4A5)

A6 45 TFSi Mild Hybrid (For OE-No. 06K905601L)	4A2, 4A5	2.0	180	4	08.18-	DKNA, DLHA	0,8	ILFER7C8EG	91898		
A6 2.0	4A5	2.0	79	4	06.94-07.95	ADW	0,8	BUR6ET	3172	1	LPG 2

A7 (4GA)

A7 Sportback 3.0 TFSi	4GA	3.0	220	6	07.10-	CGWB	0,8	PFR8S8EG	94460		
A7 Sportback 3.0 TFSi	4GA	3.0	228	6	05.11-	CGXB	0,8	PFR8S8EG	94460		
A7 Sportback 3.0 TFSi quattro	4GA	3.0	228	6	11.11-	CTTA	0,8	PFR8S8EG	94460		
A7 Sportback 3.0 TFSi quattro	4GA	3.0	245	6	05.14-	CREC	0,8	PFR8S8EG	94460		

A7 (4GF)

A7 Sportback 2.0 TFSi	4GF	2.0	185	4	09.14-	CYPA	0,8	PLFER7A8EG	94833		
-----------------------	-----	-----	-----	---	--------	------	-----	------------	-------	--	--

A7 (4KA)

A7 45 TFSi Mild Hybrid (For OE-No. 06K905601L)	4KA	2.0	180	4	07.18-	DKNA, DLHA	0,8	ILFER7C8EG	91898		
A7 55 TFSi Mild Hybrid	4KA	3.0	250	6	10.17-	DLZA	0,7	SILKGR9A7ES	93560		

A8

A8		4.2	210	8	06.94-12.98	AGH	0,8	BUR6EFSZ	6837		
----	--	-----	-----	---	-------------	-----	-----	----------	------	--	--





kW
C
Y
I



Stock-N°

VLINE

LPG/CNG

AUDI

A8

A8 (CH)	6.0	331	12	02.05-	BTE	1,1	PZFR6J-11	3586		LPG 6
---------	-----	-----	----	--------	-----	-----	-----------	------	--	-------

A8 (4D8)

A8 Quattro 4.2	4D8	4.2	175	8	02.99-04.00	ARU	0,5	BKR6EQUA	6872		LPG 1
----------------	-----	-----	-----	---	-------------	-----	-----	----------	------	--	-------

A8 1 (4D2)

A8 2.8	4D2	2.8	120	6	07.95-03.96	AEJ	0,8	PFR5B-9	2392		PFR6B
A8 2.8	4D2	2.8	128	6	06.94-03.96	AAH	1,0	BKUR6ET-10	2397	24	LPG 1
A8 2.8	4D2	2.8	142	6	04.96-09.98	ACK	0,5	BKR6EKUB	3584		LPG 1
A8 2.8	4D2	2.8	142	6	10.97-12.98	ALG	0,5	BKR6EKUB	3584		LPG 1
A8 2.8	4D2	2.8	142	6	01.99-02.01	APR, AQD	0,5	BKR6EKUB	3584		LPG 1
A8 2.8	4D2	2.8	142	6	05.00-09.02	AMX	0,5	BKR6EKUB	3584		LPG 1
A8 Quattro 3.0	4E2 D3	3.0	160	6	11.03-05.04	BBJ	0,5	BKR6EKUB	3584		LPG 1
A8 3.7	4D2	3.7	169	8	07.95-12.98	AEW	0,8	BUR6EFSZ	6837		
A8 3.7	4D2	3.7	169	8	05.97-12.98	AKJ	0,8	BUR6EFSZ	6837		
A8 3.7	4D2	3.7	191	8	10.98-09.02	AKC, AQG	0,5	BKR6EQUA	6872		LPG 1
A8 Quattro 3.7	4D2	3.7	191	8	10.98-09.02	AKC, AQG	0,5	BKR6EQUA	6872		LPG 1
A8 4.2 quattro	4D2	4.2	180	8	06.94-07.96	AEM	0,8	BUR6EFSZ	6837		
A8 4.2 quattro	4D2	4.2	220	8	06.94-05.99	ABZ	0,8	BUR6EFSZ	6837		
A8 4.2 quattro	4D2	4.2	220	8	06.97-12.98	AKG	0,8	BUR6EFSZ	6837		
A8 4.2 quattro	4D2	4.2	228	8	10.98-09.02	AQF, AUW	0,5	BKR6EQUA	6872		LPG 1
A8 S8 4.2 quattro	4D2	4.2	250	8	09.96-12.98	AHC	0,8	BUR6EFSZ	6837		
A8 S8 4.2 quattro	4D2	4.2	250	8	08.97-12.98	AKH	0,8	BUR6EFSZ	6837		
A8 6.0 W12 quattro	4D2	6.0	309	12	03.01-09.02	AZC	1,1	PZFR6J-11	3586		LPG 6

A8 2 (4E)

A8 2.8 FSI	4E	2.8	154	6	09.07-07.10	BDX	1,1	PFR6X-11	5757		
A8 3.0	4E	3.0	160	6	07.03-05.06	BBJ	0,5	BKR6EKUB	3584		LPG 1
A8 3.0	4E	3.0	162	6	07.03-05.05	ASN	0,5	BKR6EKUB	3584		LPG 1
A8 3.2 FSI	4E	3.2	191	6	06.05-07.10	BPK	0,9	PFR7W-T	6840		
A8 3.7 quattro	4E	3.7	206	8	11.02-05.06	BFL	0,5	BKR6EQUA	6872		LPG 1
A8 4.2 quattro	4E	4.2	246	8	11.02-05.06	BFM	0,5	BKR6EQUA	6872		LPG 1
A8 4.2 FSI quattro	4E	4.2	257	8	06.06-07.10	BVJ	0,9	PFR6W-TG	5547		
A8 S8 5.2 quattro	4E	5.2	331	10	06.06-07.10	BSM	0,9	PFR6W-TG	5547		
S8 Quattro 5.2	4E2, 4E8	5.2	331	10	06.06-07.10	BSM	0,9	PFR6W-TG	5547		
A8 6.0 W12 quattro	4E	6.0	331	12	02.04-07.10	BHT	1,1	PZFR6J-11	3586		LPG 6

A8 3 (4H)

A8 2.0 TFSI Hybrid	4H	2.0	155	4	02.12-	CHJA	0,8	PFR7S8EG	1675	50	PFR8S8EG
A8 3.0 TFSI quattro	4H	3.0	213	6	07.10-	CGWA, CGXA	0,8	PFR8S8EG	94460		
A8 3.0 TFSI quattro	4H	3.0	228	6	11.11-	CGWD	0,8	PFR8S8EG	94460		
A8 3.0 TFSI quattro	4H	3.0	245	6	06.10-	CMDA	0,8	PFR8S8EG	94460		
A8 3.0 TFSI quattro	4H	3.0	245	6	05.11-	CGXC	0,8	PFR8S8EG	94460		
A8 4.2 FSI quattro	4H	4.2	273	8	11.09-	CDRA	0,9	PFR6W-TG	5547		
A8 6.3 W12 quattro	4H	6.3	368	12	01.11-	CEJA	0,8	ILZKR8A	94290		

A8 4 (4N2/4N8)

A8 50 TFSi Mild Hybrid	4N8	3.0	210	6	07.18-	CZSA	0,7	SILKGR9A7ES	93560		
A8 55 TFSi Mild Hybrid/60 TFSi e	4N2, 4N8	3.0	250	6	06.17-	CZSE	0,7	SILKGR9A7ES	93560		





l kW C
Y I



Stock-N°

VLINE

LPG/CNG

AUDI

CABRIO

Cabrio 1.8	1.8	92	4	04.97-08.00	ADR	1,0	BKUR6ET-10	2397	24	LPG 1
Cabrio 2.0	2.0	85	4	01.93-09.98	ABK	0,8	BUR6ET	3172	1	LPG 2
Cabrio 2.0	2.0	103	4	05.95-07.96	ACE	0,8	BKUR7ET	7873		
Cabrio2.3	2.3	98	5	06.91-07.94	NG	0,8	BUR5ET	3377	22	LPG 2
Cabrio 2.6 (China / GUS)	2.6	102	6	05.95-12.99	ACZ	1,0	BKUR6ET-10	2397	24	LPG 1
Cabrio 2.6	2.6	110	6	01.94-08.00	ABC	1,0	BKUR6ET-10	2397	24	LPG 1
Cabrio 2.8	2.8	128	6	11.92-08.00	AAH	1,0	BKUR6ET-10	2397	24	LPG 1

Q2 (GAB)

Q2 30 TFSi/TFSi	GAB	1.0	85	3	10.16-	CHZJ, DKRF	0,8	IKER7A8EGS	94224		
Q2 1.4 TFSi ACT	GAB	1.4	110	4	06.16-	CZEA	0,8	PKER7A8EGS	95463		
Q2 35 TFSi	GAB	1.5	110	4	07.18-	DADA, DPCA	0,8	ILKER7A8EGS	95929		
SQ2 2.0 TFSi	GAB	2.0	221	4	08.18-	DNUE	0,8	ILFER7C8EG	91898		

Q3 (8UB)

Q3 1.4 TFSi	8UB	1.4	110	4	10.13-	CHPB, CZDA, CZEA	0,8	PZKER7B8EGS	93231	55	
Q3 2.0 TFSi	8UB	2.0	125	4	06.11-	CCZC	0,8	PFR7S8EG	1675	50	PFR8S8EG
Q3 2.0 TFSi	8UB	2.0	155	4	06.11-	CPSA	0,8	PFR7S8EG	1675	50	PFR8S8EG

Q3 (F3B)

Q3 35 TFSi	F3B	1.5	110	4	08.18-	DADA, DPCA	0,8	ILKER7A8EGS	95929		
Q3 35 TFSi Mild Hybrid	F3B	1.5	110	4	11.19-	DFYA	0,8	ILKER7A8EGS	95929		
Q3 40 TFSi	F3B	2.0	140	4	09.18-	DKTC	0,8	ILFER7C8EG	91898		
Q3 45 TFSi	F3B	2.0	169	4	07.18-	DKTA	0,8	ILFER7C8EG	91898		
RSQ3 Quattro 2.5 TFSi	F3B	2.5	294	5	10.19-	DAZA, DNWA	0,7	SILFER8C7ES	91006		

Q3 (F3N)

Q3 35 TFSi	F3N	1.5	110	4	09.19-	DPCA	0,8	ILKER7A8EGS	95929		
Q3 35 TFSi Mild Hybrid	F3N	1.5	110	4	11.19-	DFYA	0,8	ILKER7A8EGS	95929		
RSQ3 Sportback Quattro 2.5 TFSi	F3N	2.5	294	5	10.19-	DAZA, DNWA	0,7	SILFER8C7ES	91006		

Q5 (8R)

Q5 2.0 TFSi	8R	2.0	130	4	09.09-10.09	CDNA	0,8	PFR7S8EG	1675	50	PFR8S8EG
Q5 2.0 TFSi	8R	2.0	132	4	08.09-	CDNB	0,8	PFR7S8EG	1675	50	PFR8S8EG
Q5 2.0 TFSi	8R	2.0	155	4	11.08-09.12	CDNC	0,8	PFR7S8EG	1675	50	PFR8S8EG
Q5 2.0 TFSi	8R	2.0	155	4	05.10-09.12	CAEB	0,8	PFR7S8EG	1675	50	PFR8S8EG
Q5 2.0 TFSi Hybrid	8R	2.0	155	4	06.11-	CHJA	0,8	PFR7S8EG	1675	50	PFR8S8EG
Q5 3.2 V6 FSI	8R	3.2	199	6	11.08-09.12	CALB	1,1	PFR6X-11	5757		

Q5 (FYB)

Q5 45 TFSi Mild Hybrid	FYB	2.0	180	4	08.18-	DNTA	0,8	ILFER7C8EG	91898		
SQ5 3.0 TFSi	FYB	3.0	260	6	11.16-	CWGD	0,7	SILKGR9A7ES	93560		

Q7 (4L)

Q7 3.0 TFSi	4L	3.0	200	6	05.10-	CJTC, CJWB, CTWA	0,8	PFR8S8EG	94460		
Q7 3.0 TFSi	4L	3.0	200	6	07.10-	CJWC	0,8	PFR8S8EG	94460		
Q7 3.0 TFSi	4L	3.0	245	6	05.10-	CJTB	0,8	PFR8S8EG	94460		
Q7 3.0 TFSi	4L	3.0	245	6	07.10-	CNAA	0,8	PFR8S8EG	94460		
Q7 3.6 FSI	4L	3.6	206	6	08.06-05.10	BHK	0,9	ILZKR7A	1961		
Q7 4.2 FSI	4L	4.2	257	8	03.06-12.10	BAR	0,9	PFR6W-TG	5547		

Q7 (4LB)

Q7 3.0 TFSi quattro	4LB	3.0	245	6	05.10-08.15	CJWB, CTWA	0,8	PFR8S8EG	94460		
---------------------	-----	-----	-----	---	-------------	------------	-----	----------	-------	--	--





l kW C
Y
I



Stock-N°

VLINE

LPG/CNG

AUDI

Q7 (4LB)

Q7 Quattro 4.2 FSi	4LB	4.2	257	8	03.06-05.10	BAR	0,9	PFR6W-TG	5547		
--------------------	-----	-----	-----	---	-------------	-----	-----	----------	------	--	--

Q7 (4MB)

Q7 55 TFSi Mild Hybrid	4MB	3.0	250	6	07.19-	DCBD	0,7	SILKGR9A7ES	93560		
------------------------	-----	-----	-----	---	--------	------	-----	-------------	-------	--	--

Q8 (4MN)

Q8 55 TFSi Mild Hybrid	4MN	3.0	250	6	02.18-	DCBD	0,7	SILKGR9A7ES	93560		
------------------------	-----	-----	-----	---	--------	------	-----	-------------	-------	--	--

R8

R8 4.2		4.2	309	8	04.07-	BYH	0,9	PFR7W-TG	5592		
--------	--	-----	-----	---	--------	-----	-----	----------	------	--	--

R8 5.2		5.2	386	10	04.09-09.10	BUJ	0,9	PFR7W-TG	5592		
--------	--	-----	-----	----	-------------	-----	-----	----------	------	--	--

R8 Spyder Quattro 5.2 FSi	429	5.2	386	10	02.10-09.10	BUJ, CTYA	0,9	PFR7W-TG	5592		
---------------------------	-----	-----	-----	----	-------------	-----------	-----	----------	------	--	--

R8 5.2		5.2	386	10	09.10-	BUJ	0,8	PFR7S8EG	1675	50	PFR8S8EG
--------	--	-----	-----	----	--------	-----	-----	----------	------	----	----------

R8 5.2 GT		5.2	412	10	11.10-	CMPA	0,8	PFR7S8EG	1675	50	PFR8S8EG
-----------	--	-----	-----	----	--------	------	-----	----------	------	----	----------

R8 Spyder Quattro 5.2 FSi Plus	4S9	5.2	449	10	05.17-05.17	CSPA	0,8	PFR7S8EG	1675	50	PFR8S8EG
--------------------------------	-----	-----	-----	----	-------------	------	-----	----------	------	----	----------

TT (8J3/8J9)

TT 1.8TFSI	8J3, 8J9	1.8	118	4	06.08-	CDAA	0,8	PFR7S8EG	1675	50	PFR8S8EG
------------	----------	-----	-----	---	--------	------	-----	----------	------	----	----------

TT 2.0 TFSI	8J3, 8J9	2.0	147	4	08.06-	BWA	0,8	PFR7S8EG	1675	50	PFR8S8EG
-------------	----------	-----	-----	---	--------	-----	-----	----------	------	----	----------

TT 2.0 TFSI	8J3, 8J9	2.0	147	4	06.08-06.10	CCZA	0,8	PFR7S8EG	1675	50	PFR8S8EG
-------------	----------	-----	-----	---	-------------	------	-----	----------	------	----	----------

TT 2.0 TFSI	8J3, 8J9	2.0	155	4	05.10-06.14	CESA	0,8	PFR7S8EG	1675	50	PFR8S8EG
-------------	----------	-----	-----	---	-------------	------	-----	----------	------	----	----------

TT 2.0 TFSI quattro	8J3, 8J9	2.0	155	4	05.10-06.14	CETA	0,8	PFR7S8EG	1675	50	PFR8S8EG
---------------------	----------	-----	-----	---	-------------	------	-----	----------	------	----	----------

TT 2.0 TFSI quattro	8J3, 8J9	2.0	195	4	05.08-	CDLA	0,8	PFR7S8EG	1675	50	PFR8S8EG
---------------------	----------	-----	-----	---	--------	------	-----	----------	------	----	----------

TT 2.0 TFSI quattro	8J3, 8J9	2.0	195	4	05.10-	CDMA	0,8	PFR7S8EG	1675	50	PFR8S8EG
---------------------	----------	-----	-----	---	--------	------	-----	----------	------	----	----------

TT 2.0 TFSI quattro	8J3, 8J9	2.0	200	4	05.08-	CDLB	0,8	PFR7S8EG	1675	50	PFR8S8EG
---------------------	----------	-----	-----	---	--------	------	-----	----------	------	----	----------

TT 3.2 V6 quattro	8J3, 8J9	3.2	184	6	08.06-	BUB	0,9	IZKR7B	7563		
-------------------	----------	-----	-----	---	--------	-----	-----	--------	------	--	--

TT (8N3)

TT 1.8 (Chassis No →8NX015500)	8N3	1.8	132	4	10.98-06.06	AJQ, APP, ATC, AUQ	1,0	BKUR6ET-10	2397	24	LPG 1
--------------------------------	-----	-----	-----	---	-------------	--------------------	-----	------------	------	----	-------

TT Quattro 1.8 (Chassis No →8NX015500)	8N3	1.8	132	4	10.98-06.06	AJQ, ARY, ATC, AUQ	1,0	BKUR6ET-10	2397	24	LPG 1
--	-----	-----	-----	---	-------------	--------------------	-----	------------	------	----	-------

TT Quattro 1.8	8N3	1.8	165	4	10.98-12.98	APX, BAM	1,0	BKUR6ET-10	2397	24	LPG 1
----------------	-----	-----	-----	---	-------------	----------	-----	------------	------	----	-------

TT (8N3/8N9)

TT 1.8T	8N3, 8N9	1.8	110	4	01.01-06.06	AUM	0,8	PFR6Q	6458	37	LPG 1
---------	----------	-----	-----	---	-------------	-----	-----	-------	------	----	-------

TT 1.8T	8N3, 8N9	1.8	120	4	09.05-06.06	BVP	0,8	PFR6Q	6458	37	LPG 1
---------	----------	-----	-----	---	-------------	-----	-----	-------	------	----	-------

TT 1.8T	8N3, 8N9	1.8	132	4	10.98-08.00	AJQ	0,8	PFR6Q	6458	37	LPG 1
---------	----------	-----	-----	---	-------------	-----	-----	-------	------	----	-------

TT 1.8T	8N3, 8N9	1.8	132	4	09.99-09.00	APP	0,8	PFR6Q	6458	37	LPG 1
---------	----------	-----	-----	---	-------------	-----	-----	-------	------	----	-------

TT 1.8T	8N3, 8N9	1.8	132	4	09.00-05.05	ARY	0,8	PFR6Q	6458	37	LPG 1
---------	----------	-----	-----	---	-------------	-----	-----	-------	------	----	-------

TT 1.8T	8N3, 8N9	1.8	132	4	09.00-06.06	AUQ	0,8	PFR6Q	6458	37	LPG 1
---------	----------	-----	-----	---	-------------	-----	-----	-------	------	----	-------

TT 1.8T (For USA)	8N3, 8N9	1.8	132	4	09.00-06.06	AWP	0,8	PFR6Q	6458	37	LPG 1
-------------------	----------	-----	-----	---	-------------	-----	-----	-------	------	----	-------

TT 1.8T quattro	8N3, 8N9	1.8	140	4	09.05-06.06	BVR	0,8	PFR6Q	6458	37	LPG 1
-----------------	----------	-----	-----	---	-------------	-----	-----	-------	------	----	-------

TT 1.8T quattro	8N3, 8N9	1.8	165	4	10.98-08.01	APX	0,8	PFR6Q	6458	37	LPG 1
-----------------	----------	-----	-----	---	-------------	-----	-----	-------	------	----	-------

TT 1.8T (For USA)	8N3, 8N9	1.8	165	4	03.00-08.02	AMU	0,8	PFR6Q	6458	37	LPG 1
-------------------	----------	-----	-----	---	-------------	-----	-----	-------	------	----	-------

TT 1.8T quattro	8N3, 8N9	1.8	165	4	09.00-05.05	BAM	0,8	PFR6Q	6458	37	LPG 1
-----------------	----------	-----	-----	---	-------------	-----	-----	-------	------	----	-------

TT 1.8T quattro	8N3, 8N9	1.8	180	4	03.05-05.05	BFV	0,8	PFR6Q	6458	37	LPG 1
-----------------	----------	-----	-----	---	-------------	-----	-----	-------	------	----	-------

TT 3.2 V6 quattro	8N3, 8N9	3.2	184	6	07.03-06.06	BHE	0,9	IZKR7B	7563		
-------------------	----------	-----	-----	---	-------------	-----	-----	--------	------	--	--

TT (8N9)

TT 1.8 (Chassis No →8NX015500)	8N9	1.8	132	4	10.98-06.06	AJQ, APP, ATC, AUQ	1,0	BKUR6ET-10	2397	24	LPG 1
--------------------------------	-----	-----	-----	---	-------------	--------------------	-----	------------	------	----	-------

TT Quattro 1.8 (Chassis No →8NX015500)	8N9	1.8	132	4	10.98-06.06	AJQ, ARY, AUQ	1,0	BKUR6ET-10	2397	24	LPG 1
--	-----	-----	-----	---	-------------	---------------	-----	------------	------	----	-------



e kW C
Y I

Stock-N°

VLINE

LPG/CNG

AUDI**TT (FV3/FV9)**

TT RS 2.5 TFSi quattro	FV3, FV9	2.5	294	5	05.16-	DAZA	0,7	SILFER8C7ES	91006		
------------------------	----------	-----	-----	---	--------	------	-----	-------------	-------	--	--

TT (FVP/FVR)

TT 40 TFSi	FVP, FVR	2.0	145	4	07.18-	DKZB	0,8	ILFER7C8EG	91898		
TT 45 TFSi	FVP, FVR	2.0	180	4	07.18-	DKTB	0,8	ILFER7C8EG	91898		
TTS 2.0 TFSi (For OE-No. 06K905601L)	FVP, FVR	2.0	225	4	08.18-	DNUF	0,8	ILFER7C8EG	91898		

AUSTIN**METRO**

Metro 310		1.0		4	09.89-04.92		0,7	BP6ES	7811	4	LPG 2
Metro 310		1.3		4	09.89-04.92		0,8	BPR6ES	7822	2	LPG 2

AUTOBIANCHI**Y10**

Y10 Fire		1.0	32	4	10.87-09.92	156A2.100 Cat	0,8	BCPR6ES	2330	12	LPG 3
Y10 i.e Mia		1.1	37	4	01.94-10.96	156C.046	0,8	BCPR6ES	2330	12	LPG 3
Y10 i.e Igloo		1.1	37	4	03.94-10.96	156C.046	0,8	BCPR6ES	2330	12	LPG 3
Y10 i.e Junior		1.1	37	4	03.94-10.96	156C.046	0,8	BCPR6ES	2330	12	LPG 3
Y10 i.e 4WD Sestrieres		1.1	37	4	03.94-10.96	156C.046	0,8	BCPR6ES	2330	12	LPG 3
Y10 i.e Selectronic Ville		1.1	37	4	03.94-01.95	156C.046	0,8	BCPR6ES	2330	12	LPG 3
Y10 Fire IE (all models)		1.1	41	4	01.89-10.96	156C.000	0,8	BCPR6ES	2330	12	LPG 3
Y10 i.e GT/i.e GT Kat./Elite		1.3	53	4	11.87-09.92	156C5.046	0,8	BPR6ES	7822	2	LPG 2

AZLK (MOSKWITCZ)**ALEKO**

Aleko		1.5		4	-12.00		0,8	BP7ES	2412		BPR8EIX
Aleko		1.8	70	4	12.86-12.00		0,8	BPR6ES	7822	2	LPG 2
Aleko		2.0	83	4	01.86-12.00	REN-F3R	0,9	BPR5ES	7422	6	LPG 2

BENTLEY**BENTAYGA**

Bentayga 3.0 Hybrid	4V1	3.0	250	6	08.18-	DCBE	0,7	SILKGR9A7ES	93560		
---------------------	-----	-----	-----	---	--------	------	-----	-------------	-------	--	--

CONTINENTAL

Continental GT, GTC 4.0	393, 394	4.0	373	8	07.16-	CMMC, CYCB	0,7	SILFER8C7ES	91006		
Continental GT, GTC 4.0 -/S	393	4.0	388	8	07.16-	CMMD, CYCA	0,7	SILFER8C7ES	91006		

FLYING SPUR

Flying Spur 4.0	4W2	4.0	373	8	07.16-	CMMC, CYCB	0,7	SILFER8C7ES	91006		
Flying Spur 4.0 S	4W2	4.0	388	8	07.16-	CYCA	0,7	SILFER8C7ES	91006		

BMW**1 (SERIES) E81**

116i 1.6	E81	1.6	85	4	08.07-	N45B16	0,5	BKR6EQU	6002		LPG 1
116i 1.6	E81	1.6	90	4	08.07-09.12	N43B16	0,5	ZKBR7A-HTU	91785		
118i 2.0	E81	2.0	95	4	09.06-	N46B20	1,1	IZFR6H11	4294		
118i 2.0	E81	2.0	105	4	05.07-	N43B20	0,5	ZKBR7A-HTU	91785		
120i 2.0	E81	2.0	125	4	03.07-09.12	N43B20	0,5	ZKBR7A-HTU	91785		
130i 3.0	E81	3.0	190	6	03.05-09.12	N52B30A, N52B30B, N52B30BF	1,1	ILZFR6D11	1208		
130i 3.0	E81	3.0	195	6	09.06-	N52B30	1,1	ILZFR6D11	1208		
130i 3.0	E81	3.0	195	6	03.07-11.09	N52B30A, N52B30B, N52B30BF	1,1	PLZFR6A-11S	5987		





l kW
C
Y
I



Stock-N°

VLINE

LPG/CNG

BMW

1 (SERIES) E81

130i 3.0	E81	3.0	195	6	12.09-09.12	N52B30A, N52B30B, N52B30BF	1.1	LZFR6AP11GS	95712		
----------	-----	-----	-----	---	-------------	----------------------------	-----	-------------	-------	--	--

1 (SERIES) E82

120i Coupe 2.0	E82	2.0	115	4	06.09-	N46B20B	0,5	ZKBR7A-HTU	91785		
125i Coupe 3.0	E82	3.0	160	6	03.08-11.09	N52B30A, N52B30B, N52B30BF	1,1	ILZFR6D11	1208		
125i Coupe 3.0	E82	3.0	160	6	03.08-11.09	N52B30A, N52B30B, N52B30BF	1,1	PLZFR6A-11S	5987		
125i Coupe 3.0	E82	3.0	160	6	12.09-	N52B30A, N52B30B, N52B30BF	1,1	LZFR6AP11GS	95712		

1 (SERIES) E87

116i 1.6	E87	1.6	85	4	09.04-	N45B16	0,5	BKR6EQU	6002		LPG 1
116i 1.6	E87	1.6	90	4	08.07-	N43B16	0,5	ZKBR7A-HTU	91785		
116i 2.0	E87	2.0	90	4	10.07-09.12	N43B20A	0,5	ZKBR7A-HTU	91785		
118i 2.0	E87	2.0	95	4	09.04-	N46B20	1,1	IZFR6H11	4294		
118i 2.0	E87	2.0	105	4	05.07-	N43B20	0,5	ZKBR7A-HTU	91785		
120i 2.0	E87	2.0	110	4	09.04-	N46B20	1,1	IZFR6H11	4294		
120i 2.0	E87	2.0	120	4	03.07-09.12	N43B20A	0,5	ZKBR7A-HTU	91785		
120i 2.0	E87	2.0	125	4	12.06-09.12	N43B20	0,5	ZKBR7A-HTU	91785		
130i 3.0	E87	3.0	190	6	03.07-11.09	N52B30A, N52B30B, N52B30BF	1,1	ILZFR6D11	1208		
130i 3.0	E87	3.0	190	6	03.07-11.09	N52B30A, N52B30B, N52B30BF	1,1	PLZFR6A-11S	5987		
130i 3.0	E87	3.0	190	6	12.09-06.11	N52B30A, N52B30B, N52B30BF	1,1	LZFR6AP11GS	95712		
130i 3.0	E87	3.0	195	6	09.05-	N52B30	1,1	ILZFR6D11	1208		
130i 3.0	E87	3.0	195	6	09.05-02.07	N52B30A, N52B30BF	1,1	ILZFR6D11	1208		
130i 3.0	E87	3.0	195	6	09.05-02.07	N52B30A, N52B30BF	1,1	PLZFR6A-11S	5987		
130i 3.0	E87	3.0	195	6	01.10-09.12	N52B30A, N52B30B, N52B30BF	1,1	LZFR6AP11GS	95712		

1 (SERIES) E88

118i Cabrio 2.0	E88	2.0	105	4	04.08-	N43B20	0,5	ZKBR7A-HTU	91785		
120i Cabrio 2.0	E88	2.0	125	4	04.08-	N43B20	0,5	ZKBR7A-HTU	91785		
125i Cabrio 3.0	E88	3.0	160	6	12.07-11.09	N52B30A, N52B30B, N52B30BF	1,1	ILZFR6D11	1208		
125i Cabrio 3.0	E88	3.0	160	6	12.07-11.09	N52B30A, N52B30B, N52B30BF	1,1	PLZFR6A-11S	5987		
125i Cabrio 3.0	E88	3.0	160	6	12.09-	N52B30A, N52B30B, N52B30BF	1,1	LZFR6AP11GS	95712		

1 (SERIES) F20

114i 1.6	F20	1.6	75	4	11.11-	N13B16A	0,8	PLZKBR7B8G	91530		
116i 1.5	F20	1.5	80	3	03.15-	B38B15A	0,8	SILZKGR8B8S	94201		
116i 1.6	F20	1.6	100	4	06.11-	N13B16A	0,8	PLZKBR7B8G	91530		
118i 1.5	F20	1.5	100	3	03.15-	B38B15A	0,8	SILZKGR8B8S	94201		
118i 1.5	F20	1.5	100	3	07.15-06.19	B38B15A	0,8	SILZKGR8B8S	94201		
118i 1.6	F20	1.6	125	4	06.11-	N13B16A	0,8	PLZKBR7B8G	91530		
120i 1.6	F20	1.6	130	4	03.15-	N13B16A	0,8	PLZKBR7B8G	91530		
120i 2.0	F20	2.0	135	4	09.15-	B48B20A	0,8	SILZKGR8B8S	94201		
120i 2.0	F20	2.0	135	4	07.16-06.19	B48B20A	0,8	SILZKGR8B8S	94201		
125i 2.0	F20	2.0	160	4	03.12-	N20B20A	0,75	SILZKBR8D8S	97506		
125i 2.0	F20	2.0	160	4	08.14-	N20B20A	0,75	SILZKBR8D8S	97506		
125i 2.0	F20	2.0	165	4	09.15-	B48B20B	0,8	SILZKGR8B8S	94201		
125i 2.0	F20	2.0	175	4	07.12-	N20B20A	0,75	SILZKBR8D8S	97506		





l kW C
Y
I



Stock-N°

VLINE

LPG/CNG

BMW

1 (SERIES) F20

M140i xDrive 3.0	F20	3.0	250	6	09.15-	B58B30A	0,8	SILZKGR8B8S	94201		
M140i 3.0	F20	3.0	250	6	10.15-	B58B30A	0,8	SILZKGR8B8S	94201		
M140i 3.0	F20	3.0	250	6	07.16-06.19	B58B30A	0,8	SILZKGR8B8S	94201		

1 (SERIES) F21

116i 1.5	F21	1.5	80	3	03.15-	B38B15A	0,8	SILZKGR8B8S	94201		
118i 1.5	F21	1.5	100	3	03.15-	B38B15A	0,8	SILZKGR8B8S	94201		
120i 1.6	F21	1.6	130	4	03.15-	N13B16A	0,8	PLZKBR7B8G	91530		
120i 2.0	F21	2.0	135	4	10.15-	B48B20A	0,8	SILZKGR8B8S	94201		
125i 2.0	F21	2.0	160	4	12.11-	N20B20A	0,75	SILZKBR8D8S	97506		
125i 2.0	F21	2.0	165	4	10.15-	B48B20B	0,8	SILZKGR8B8S	94201		
125i 2.0	F21	2.0	175	4	07.12-	N20B20A	0,75	SILZKBR8D8S	97506		
M140i xDrive 3.0	F21	3.0	250	6	09.15-	B58B30A	0,8	SILZKGR8B8S	94201		
M140i 3.0	F21	3.0	250	6	10.15-	B58B30A	0,8	SILZKGR8B8S	94201		

2 (SERIES) F22

218i Coupe 1.5	F22	1.5	100	3	01.15-	B38B15A	0,8	SILZKGR8B8S	94201		
220i Coupe 2.0	F22	2.0	135	4	04.15-	N20B20A, N20B20B	0,75	SILZKBR8D8S	97506		
220i Coupe 2.0	F22	2.0	135	4	09.15-	B48B20A	0,8	SILZKGR8B8S	94201		
228i Coupe 2.0	F22	2.0	180	4	04.15-	N20B20A	0,75	SILZKBR8D8S	97506		
230i Coupe 2.0	F22	2.0	185	4	09.15-	B48B20B	0,8	SILZKGR8B8S	94201		
M240i Coupe 3.0	F22	3.0	250	6	09.15-	B58B30A	0,8	SILZKGR8B8S	94201		
M240i xDrive Coupe 3.0	F22	3.0	250	6	09.15-	B58B30A	0,8	SILZKGR8B8S	94201		

2 (SERIES) F23

218i Cabrio 1.5	F23	1.5	100	3	01.15-	B38B15A	0,8	SILZKGR8B8S	94201		
220i Cabrio 2.0	F23	2.0	135	4	04.15-	N20B20A, N20B20B	0,75	SILZKBR8D8S	97506		
220i Cabrio 2.0	F23	2.0	135	4	09.15-	B48B20A	0,8	SILZKGR8B8S	94201		
228i Cabrio 2.0	F23	2.0	180	4	04.15-	N20B20A	0,75	SILZKBR8D8S	97506		
230i Cabrio 2.0	F23	2.0	185	4	09.15-	B48B20B	0,8	SILZKGR8B8S	94201		
M240i Cabrio 3.0	F23	3.0	250	6	09.15-	B58B30A	0,8	SILZKGR8B8S	94201		
M240i xDrive Cabrio 3.0	F23	3.0	250	6	09.15-	B58B30A	0,8	SILZKGR8B8S	94201		

2 (SERIES) F45

216i Active Tourer 1.5	F45	1.5	75	3	11.15-	B38A15A	0,8	SILZKGR8B8S	94201		
218i Active Tourer 1.5	F45	1.5	100	3	09.14-	B38A15A	0,8	SILZKGR8B8S	94201		
220i Active Tourer 2.0	F45	2.0	120	4	11.14-	B48A20A	0,8	SILZKGR8B8S	94201		
220i Active Tourer 2.0	F45	2.0	141	4	09.14-	B48A20A	0,8	SILZKGR8B8S	94201		
225e xDrive Active Tourer 1.5 Hybrid	F45	1.5	100	3	03.16-	B38A15A	0,8	SILZKGR8B8S	94201		
225i Active Tourer 2.0	F45	2.0	170	4	09.14-	B48A20B	0,8	SILZKGR8B8S	94201		
225i xDrive Active Tourer 2.0	F45	2.0	170	4	09.14-	B48A20B	0,8	SILZKGR8B8S	94201		

2 (SERIES) F46

216i Gran Tourer 1.5	F46	1.5	75	3	07.15-	B38A15A	0,8	SILZKGR8B8S	94201		
218i Gran Tourer 1.5	F46	1.5	100	3	03.15-	B38A15A	0,8	SILZKGR8B8S	94201		
220i Gran Tourer 2.0	F46	2.0	120	4	03.15-	B48A20A	0,8	SILZKGR8B8S	94201		
220i Gran Tourer 2.0	F46	2.0	141	4	03.15-	B48A20A	0,8	SILZKGR8B8S	94201		

3 (SERIES) E30

316i 1.6	E30	1.6	73	4	09.88-09.94	M40B16	0,9	BKR6EK	2288	20	LPG 1
318i Touring 1.8	E30	1.8	82	4	04.89-09.94	M40B18	0,9	BKR6EK	2288	20	LPG 1





l kW C
Y
I



Stock-N°

VLINE

LPG/CNG

BMW

3 (SERIES) E30

318i 1.8	E30	1.8	83	4	09.87-04.91	M40B18	0,9	BKR6EK	2288	20	LPG 1
320i Touring 2.0	E30	2.0	90	6	01.88-08.91	M20B20	0,8	ZGR5A	5839	15	
325i Touring 2.5	E30	2.5	125	6	07.87- .91	M20B25	0,8	ZGR5A	5839	15	
325iX 2.5	E30	2.5	125	6	12.86-01.91	M20B25	0,8	ZGR5A	5839	15	
325iX Touring 2.5	E30	2.5	125	6	06.88- .91	M20B25	0,8	ZGR5A	5839	15	

3 (SERIES) E36

316g Compact 1.6	E36, 5	1.6	65	4	02.96-07.00	M43B16	0,9	BKR6EK	2288	20	LPG 1
316i 1.6	E36	1.6	73	4	05.91-08.93	M40B16	0,9	BKR6EK	2288	20	LPG 1
316i 1.6	E36	1.6	75	4	08.93-05.99	M43B16	0,9	BKR6EK	2288	20	LPG 1
316i Compact 1.6	E36, 5	1.6	75	4	04.94-12.98	M43B16	0,9	BKR6EK	2288	20	LPG 1
316i Compact 1.9	E36, 5	1.9	77	4	04.98-08.00	M43B19	0,9	BKR6EK	2288	20	LPG 1
316i Compact 1.9	E36	1.9	77	4	01.99-08.00	M43B194E1	1,5	BKR6EQUP	3199	30	LPG 1
318i 1.8	E36	1.8	83	4	10.90-09.93	M40B18	0,9	BKR6EK	2288	20	LPG 1
318i 1.8	E36	1.8	85	4	08.93-09.99	M43B18	0,9	BKR6EK	2288	20	LPG 1
318i Touring 1.8	E36, 3	1.8	85	4	09.94-09.99	M43B18	0,9	BKR6EK	2288	20	LPG 1
318iS 1.8	E36	1.8	103	4	10.91-03.96	M42B18	0,9	BKR6EK	2288	20	LPG 1
318iS Coupe 1.9	E36	1.9	103	4	01.96-09.99	M44B19	0,9	BKR6EK	2288	20	LPG 1
318ti Compact 1.8	E36, 5	1.8	103	4	11.94-02.96	M42B18	0,9	BKR6EK	2288	20	LPG 1
318ti Compact 1.9	E36, 5	1.9	103	4	02.95-12.98	M44B19	0,9	BKR6EK	2288	20	LPG 1
320i 2.0	E36	2.0	110	6	01.90-07.95	M50B20	0,9	BKR6EK	2288	20	LPG 1
320i Touring 2.0	E36, 3	2.0	110	6	04.94-05.99	M52B20	0,9	BKR6EK	2288	20	LPG 1
320i 2.0	E36	2.0	110	6	09.94-09.99	M52B20	0,9	BKR6EK	2288	20	LPG 1
323i 2.5	E36	2.5	125	6	06.95-04.99	M52B25	0,9	BKR6EK	2288	20	LPG 1
323i Touring 2.5	E36, 3	2.5	125	6	12.95-05.99	M52B25	0,9	BKR6EK	2288	20	LPG 1
323ti Compact 2.5	E36, 5	2.5	125	6	10.97-12.98	M52B25	0,9	BKR6EK	2288	20	LPG 1
325i 2.5	E36	2.5	141	6	12.89-12.94	M50B25	0,9	BKR6EK	2288	20	LPG 1
328i 2.8	E36	2.8	142	6	01.95-09.99	M52B28	0,9	BKR6EK	2288	20	LPG 1
328i Touring 2.8	E36, 3	2.8	142	6	05.95-05.99	M52B28	0,9	BKR6EK	2288	20	LPG 1

3 (SERIES) E46

316Ci Coupe 1.6	E46	1.6	75	4	04.99-02.02	M43B16	1,5	BKR6EQUP	3199	30	LPG 1
316Ci Coupe 1.8	E46	1.8	85	4	03.02-02.04	N40B18	1,5	BKR6EQUP	3199	30	LPG 1
316Ci Coupe 1.8	E46	1.8	85	4	03.04-05.06	N45B18	1,1	IZFR6H11	4294		
316i 1.6	E46	1.6	85	4	06.02-02.05	N40B16A	1,5	BKR6EQUP	3199	30	LPG 1
316i Compact 1.6 Ti	E46	1.6	85	4	06.02-02.05	N40B16A	1,5	BKR6EQUP	3199	30	LPG 1
316i 1.6	E46	1.6	85	4	09.03-01.05	N45B16	1,1	IZFR6H11	4294		
316i 1.8	E46, 4	1.8	85	4	10.01-02.04	N42B18	1,5	BKR6EQUP	3199	30	LPG 1
316i Touring 1.8	E46, 3	1.8	85	4	10.01-02.04	N42B18	1,5	BKR6EQUP	3199	30	LPG 1
316i 1.8	E46, 4	1.8	85	4	09.03-01.05	N46B18	1,1	IZFR6H11	4294		
316i Touring 1.8	E46, 3	1.8	85	4	10.03-07.05	N46B18	1,1	IZFR6H11	4294		
316i 1.9	E46, 4	1.9	77	4	01.99-09.01	M43B19	1,5	BKR6EQUP	3199	30	LPG 1
316ti Compact 1.8	E46, 5	1.8	85	4	05.01-02.04	N42B18	1,5	BKR6EQUP	3199	30	LPG 1
316ti Compact 1.8	E46, 5	1.8	85	4	09.03-12.04	N46B18	1,1	IZFR6H11	4294		
318Ci Coupe 1.9	E46, 2	1.9	87	4	09.99-08.01	M43B19	1,5	BKR6EQUP	3199	30	LPG 1
318Ci Cabrio 2.0	E46, C	2.0	105	4	12.00-03.05	N42B20	1,5	BKR6EQUP	3199	30	LPG 1
318Ci Coupe 2.0	E46, 2	2.0	105	4	09.01-02.04	N42B20	1,5	BKR6EQUP	3199	30	LPG 1





l kW C
Y
I



Stock-N°

VLINE

LPG/CNG

BMW

3 (SERIES) E46

318Ci Coupe 2.0	E46, 2	2.0	110	4	10.03-05.06	N46B20	1,1	IZFR6H11	4294		
318Ci Cabrio 2.0	E46, C	2.0	110	4	04.05-08.06	N46B20	1,1	IZFR6H11	4294		
318i Touring 1.9	E46	1.9	85	4	10.99-09.01	M43B194E1	1,5	BKR6EQUP	3199	30	LPG 1
318i Coupe 1.9	E46	1.9	85	4	12.99-08.01	M43B194E1	1,5	BKR6EQUP	3199	30	LPG 1
318i 1.9	E46, 4	1.9	87	4	04.98-08.01	M43B19	1,5	BKR6EQUP	3199	30	LPG 1
318i Touring 1.9	E46, 3	1.9	87	4	09.00-08.01	M43B19	1,5	BKR6EQUP	3199	30	LPG 1
318i Compact 2.0 Ti	E46	2.0	100	4	03.01-12.04	N42B20A	1,5	BKR6EQUP	3199	30	LPG 1
318i 2.0	E46	2.0	100	4	09.01-02.05	N42B20A	1,5	BKR6EQUP	3199	30	LPG 1
318i Cabrio 2.0	E46	2.0	100	4	09.01-12.06	N42B20A	1,5	BKR6EQUP	3199	30	LPG 1
318i Coupe 2.0	E46	2.0	100	4	01.03-12.04	N42B20A	1,5	BKR6EQUP	3199	30	LPG 1
318i Touring 2.0	E46, 3	2.0	105	4	12.00-02.04	N42B20	1,5	BKR6EQUP	3199	30	LPG 1
318i 2.0	E46, 4	2.0	105	4	09.01-02.04	N42B20	1,5	BKR6EQUP	3199	30	LPG 1
318i Cabrio 2.0	E46	2.0	105	4	09.01-12.06	N46B20A	1,1	IZFR6H11	4294		
318i 2.0	E46, 4	2.0	105	4	10.03-02.05	N46B20	1,1	IZFR6H11	4294		
318ti Compact 2.0	E46, 5	2.0	105	4	03.01-02.04	N42B20	1,5	BKR6EQUP	3199	30	LPG 1
318 ti Compact 2.0	E46, 5	2.0	105	4	09.03-12.04	N46B20	1,1	IZFR6H11	4294		
320Ci Coupe 2.0	E46, 2	2.0	110	6	11.98-08.01	M52B20	1,5	BKR6EQUP	3199	30	LPG 1
320Ci Coupe 2.2	E46, 2	2.2	125	6	01.00-03.03	M54B22	1,5	BKR6EQUP	3199	30	LPG 1
320Ci Cabrio 2.2	E46, C	2.2	125	6	02.00-08.06	M54B22	1,5	BKR6EQUP	3199	30	LPG 1
320i 2.0	E46, 4	2.0	110	6	07.97-07.01	M52B20	1,5	BKR6EQUP	3199	30	LPG 1
320i Touring 2.0	E46, 3	2.0	110	6	05.98-08.01	M52B20	1,5	BKR6EQUP	3199	30	LPG 1
320i 2.2	E46	2.2	120	6	08.00-12.07	M54B226S1	1,5	BKR6EQUP	3199	30	LPG 1
320i 2.2	E46, 4	2.2	125	6	06.00-01.05	M54B22	1,5	BKR6EQUP	3199	30	LPG 1
320i Touring 2.2	E46, 3	2.2	125	6	05.01-07.05	M54B22	1,5	BKR6EQUP	3199	30	LPG 1
323Ci Coupe 2.5	E46, 2	2.5	125	6	03.98-08.00	M52B25	1,5	BKR6EQUP	3199	30	LPG 1
323Ci Cabrio 2.5	E46, C	2.5	125	6	11.98-09.00	M52B25	1,5	BKR6EQUP	3199	30	LPG 1
323i 2.5	E46	2.5	120	6	03.98-09.00	M52B256S4	1,5	BKR6EQUP	3199	30	LPG 1
323i 2.5	E46, 4	2.5	125	6	07.97-10.00	M52B25	1,5	BKR6EQUP	3199	30	LPG 1
325Ci Coupe 2.5	E46, 2	2.5	141	6	01.00-05.06	M54B25	1,5	BKR6EQUP	3199	30	LPG 1
325Ci Cabrio 2.5	E46, C	2.5	141	6	02.00-08.06	M54B25	1,5	BKR6EQUP	3199	30	LPG 1
325i 2.5	E46, 4	2.5	141	6	01.00-01.05	M54B25	1,5	BKR6EQUP	3199	30	LPG 1
325i Touring 2.5	E46, 3	2.5	141	6	02.00-07.05	M54B25	1,5	BKR6EQUP	3199	30	LPG 1
325ti Compact 2.5	E46, 5	2.5	141	6	03.00-12.04	M54B25	1,5	BKR6EQUP	3199	30	LPG 1
325Xi 2.5	E46, 4	2.5	141	6	01.00-12.04	M54B25	1,5	BKR6EQUP	3199	30	LPG 1
325Xi Touring 2.5	E46, 3	2.5	141	6	02.00-05.05	M54B25	1,5	BKR6EQUP	3199	30	LPG 1
328Ci Coupe 2.8	E46, 2	2.8	142	6	03.98-06.00	M52B28	1,5	BKR6EQUP	3199	30	LPG 1
328i 2.8	E46, 4	2.8	142	6	04.97-05.00	M52B28	1,5	BKR6EQUP	3199	30	LPG 1
328i Touring 2.8	E46, 3	2.8	142	6	05.98-06.00	M52B28	1,5	BKR6EQUP	3199	30	LPG 1
330Ci Coupe 3.0	E46, 2	3.0	170	6	09.99-05.06	M54B30	1,5	BKR6EQUP	3199	30	LPG 1
330Ci Cabrio 3.0	E46, C	3.0	170	6	12.99-08.06	M54B30	1,5	BKR6EQUP	3199	30	LPG 1
330i 3.0	E46	3.0	168	6	01.01-12.05	M54B306S3	1,5	BKR6EQUP	3199	30	LPG 1
330i 3.0	E46, 4	3.0	170	6	09.99-01.05	M54B30	1,5	BKR6EQUP	3199	30	LPG 1
330i Touring 3.0	E46, 3	3.0	170	6	09.99-07.05	M54B30	1,5	BKR6EQUP	3199	30	LPG 1
330Xi 3.0	E46, 4	3.0	170	6	09.99-12.04	M54B30	1,5	BKR6EQUP	3199	30	LPG 1
330Xi Touring 3.0	E46, 3	3.0	170	6	09.99-05.05	M54B30	1,5	BKR6EQUP	3199	30	LPG 1





l kW C
Y
I



Stock-N°

VLINE

LPG/CNG

BMW

3 (SERIES) E90

316i 1.6	E90	1.6	85	4	02.06-12.11	N45B16	0,5	BKR6EQU	6002		LPG 1
316i 1.6	E90	1.6	90	4	09.07-12.11	N43B16A	0,5	ZKBR7A-HTU	91785		
318i 2.0	E90	2.0	95	4	09.04-	N46B20	1,1	IZFR6H11	4294		
318i 2.0	E90	2.0	100	4	06.07-12.11	N43B20A	0,5	ZKBR7A-HTU	91785		
318i 2.0	E90	2.0	105	4	07.07-	N43B20	0,5	ZKBR7A-HTU	91785		
320i 2.0	E90	2.0	110	4	03.05-	N46B20	1,1	IZFR6H11	4294		
320i 2.0	E90	2.0	115	4	03.07-12.11	N43B20A	0,5	ZKBR7A-HTU	91785		
320i 2.0	E90	2.0	125	4	05.07-	N43B20	0,5	ZKBR7A-HTU	91785		
323i 2.5	E90	2.5	130	6	03.05-03.07	N52B25A, N52B25B, N52B25BE, N52B25BF	1,1	ILZFR6D11	1208		
323i 2.5	E90	2.5	140	6	09.06-11.09	N52B25A, N52B25BF	1,1	ILZFR6D11	1208		
323i 2.5	E90	2.5	140	6	09.06-11.09	N52B25A, N52B25BF	1,1	PLZFR6A-11S	5987		
323i 2.5	E90	2.5	140	6	03.08-12.11	N52B25A	1,1	LZFR6AP11GS	95712		
325i 2.5	E90	2.5	155	6	01.06-06.07	N52B25A	1,1	ILZFR6D11	1208		
325i 2.5	E90	2.5	160	6	12.04-11.09	N52B25A, N52B25B, N52B25BF	1,1	PLZFR6A-11S	5987		
325i 2.5 Xi	E90	2.5	160	6	09.05-08.08	N52B25A	1,1	PLZFR6A-11S	5987		
325i 2.5	E90	2.5	160	6	12.09-12.11	N52B25A, N52B25B, N52B25BF	1,1	LZFR6AP11GS	95712		
325i xDrive 2.5	E90	2.5	160	6	01.10-12.11	N52NB25A	1,1	LZFR6AP11GS	95712		
325i 3.0	E90	3.0	155	6	06.06-12.11	N53B30A	0,5	ZKBR7A-HTU	91785		
325i xDrive 3.0	E90	3.0	155	6	09.08-10.11	N53B30A	0,5	ZKBR7A-HTU	91785		
325i 3.0	E90	3.0	160	6	09.07-	N53B30	0,5	ZKBR7A-HTU	91785		
328i 3.0	E90	3.0	172	6	09.06-12.09	N51B30A	1,1	ILZFR6D11	1208		
328i 3.0	E90	3.0	172	6	09.06-12.09	N51B30A	1,1	PLZFR6A-11S	5987		
328i 3.0	E90	3.0	172	6	01.10-12.11	N51B30A	1,1	LZFR6AP11GS	95712		
320i 2.0	E90	2.0	120	4	03.07-12.11	N43B20A	0,5	ZKBR7A-HTU	91785		
330i 3.0	E90	3.0	190	6	12.04-11.09	N52B30A, N52B30BF	1,1	PLZFR6A-11S	5987		
330i 3.0	E90	3.0	190	6	03.05-	N52B30	1,1	ILZFR6D11	1208		
330i 3.0 Xi	E90	3.0	190	6	10.05-06.07	N52B30A	1,1	PLZFR6A-11S	5987		
330i 3.0	E90	3.0	190	6	12.09-10.11	N52B30A, N52B30BF	1,1	LZFR6AP11GS	95712		
330i 3.0	E90	3.0	200	6	03.07-11.09	N52B30A, N52B30BF	1,1	ILZFR6D11	1208		
330i 3.0	E90	3.0	200	6	03.07-11.09	N52B30A, N52B30BF	1,1	PLZFR6A-11S	5987		
330i 3.0	E90	3.0	200	6	07.07-	N53B30	0,5	ZKBR7A-HTU	91785		
330i 3.0	E90	3.0	200	6	12.09-12.11	N52B30A, N52B30BF	1,1	LZFR6AP11GS	95712		

3 (SERIES) E91

318i Touring 2.0	E91	2.0	95	4	03.06-	N46B20	1,1	IZFR6H11	4294		
318i Touring 2.0	E91	2.0	100	4	09.07-12.11	N43B20A	0,5	ZKBR7A-HTU	91785		
318i Touring 2.0	E91	2.0	105	4	09.07-	N43B20	0,5	ZKBR7A-HTU	91785		
320i Touring 2.0	E91	2.0	110	4	10.05-	N46B20	1,1	IZFR6H11	4294		
320i Touring 2.0	E91	2.0	115	4	06.07-10.12	N43B20A	0,5	ZKBR7A-HTU	91785		
320i Touring 2.0	E91	2.0	120	4	06.07-05.12	N43B20A	0,5	ZKBR7A-HTU	91785		
320i Touring 2.0	E91	2.0	125	4	09.07-	N43B20	0,5	ZKBR7A-HTU	91785		
323i Touring 2.5	E91	2.5	130	6	04.06-06.07	N52B25A	1,1	ILZFR6D11	1208		
325i Touring 2.5	E91	2.5	155	6	11.05-12.09	N52B25A	1,1	ILZFR6D11	1208		
325i Touring 2.5	E91	2.5	155	6	11.05-12.09	N52B25A	1,1	PLZFR6A-11S	5987		
325i Touring 2.5	E91	2.5	155	6	01.10-12.10	N52B25A	1,1	LZFR6AP11GS	95712		





l kW C
Y I



Stock-N°

VLINE

LPG/CNG

BMW

3 (SERIES) E91

325i xDrive Touring 2.5	E91	2.5	160	6	06.04-08.08	N52B25A	1,1	PLZFR6A-11S	5987		
325i Touring 2.5	E91	2.5	160	6	12.04-08.08	N52B25A	1,1	PLZFR6A-11S	5987		
325i Touring 2.5 Xi	E91	2.5	160	6	08.05-08.08	N52B25A	1,1	PLZFR6A-11S	5987		
325i Touring 3.0	E91	3.0	155	6	06.06-12.11	N53B30	0,5	ZKBR7A-HTU	91785		
325i Touring 3.0 Xi	E91	3.0	155	6	09.07-08.08	N53B30A	0,5	ZKBR7A-HTU	91785		
325i xDrive Touring 3.0	E91	3.0	155	6	09.08-06.12	N53B30A	0,5	ZKBR7A-HTU	91785		
325i Touring 3.0	E91	3.0	160	6	09.07-	N53B30	0,5	ZKBR7A-HTU	91785		
330i Touring 3.0	E91	3.0	190	6	09.05-	N52B30	1,1	ILZFR6D11	1208		
330i Touring 3.0	E91	3.0	190	6	09.05-08.07	N52B30A	1,1	PLZFR6A-11S	5987		
330i Touring 3.0 Xi	E91	3.0	190	6	10.05-08.07	N52B30A	1,1	PLZFR6A-11S	5987		
330i Touring 3.0	E91	3.0	200	6	09.07-	N53B30	0,5	ZKBR7A-HTU	91785		

3 (SERIES) E92

316i Coupe 1.6	E92	1.6	90	4	08.07-	N43B16A	0,5	ZKBR7A-HTU	91785		
320i Coupe 2.0	E92	2.0	115	4	10.06-	N46B20	1,1	IZFR6H11	4294		
320i Coupe 2.0	E92	2.0	120	4	01.07-	N43B20A	0,5	ZKBR7A-HTU	91785		
320i Coupe 2.0	E92	2.0	125	4	03.07-	N43B20	0,5	ZKBR7A-HTU	91785		
323i Coupe 2.5	E92	2.5	140	6	03.08-11.09	N52B25A	1,1	ILZFR6D11	1208		
323i Coupe 2.5	E92	2.5	140	6	03.08-11.09	N52B25A	1,1	PLZFR6A-11S	5987		
323i Coupe 2.5	E92	2.5	140	6	12.09-12.11	N52B25A	1,1	LZFR6AP11GS	95712		
325i xDrive Coupe 2.5	E92	2.5	150	6	03.12-	N52NB25A	1,1	LZFR6AP11GS	95712		
325i Coupe 2.5	E92	2.5	150	6	03.13-	N52NB25A	1,1	LZFR6AP11GS	95712		
325i Coupe 2.5	E92	2.5	155	6	03.10-06.13	N52B25A, N52B25AF, N52B25BF	1,1	ILZFR6D11	1208		
325i Coupe 2.5	E92	2.5	155	6	03.10-06.13	N52B25A, N52B25AF, N52B25BF	1,1	PLZFR6A-11S	5987		
325i Coupe 2.5	E92	2.5	160	6	06.06-02.10	N52B25A, N52B25AF, N52B25BF	1,1	PLZFR6A-11S	5987		
325i Coupe 2.5	E92	2.5	160	6	08.06-	N52NB25A, N52NB25BF	1,1	LZFR6AP11GS	95712		
325i Coupe 2.5 Xi	E92	2.5	160	6	09.06-11.09	N52B25A	1,1	PLZFR6A-11S	5987		
325i xDrive Coupe 2.5	E92	2.5	160	6	09.06-11.09	N52B25A	1,1	PLZFR6A-11S	5987		
325i Coupe 2.5 Xi	E92	2.5	160	6	12.09-02.10	N52B25A	1,1	LZFR6AP11GS	95712		
325i xDrive Coupe 2.5	E92	2.5	160	6	12.09-03.12	N52B25A	1,1	LZFR6AP11GS	95712		
325i xDrive Coupe 2.5	E92	2.5	160	6	03.10-03.12	N52NB25A	1,1	LZFR6AP11GS	95712		
325i Coupe 3.0	E92	3.0	155	6	10.06-	N53B30	0,5	ZKBR7A-HTU	91785		
325i xDrive Coupe 3.0	E92	3.0	155	6	09.08-06.13	N53B30A	0,5	ZKBR7A-HTU	91785		
325i Coupe 3.0	E92	3.0	160	6	09.07-	N53B30	0,5	ZKBR7A-HTU	91785		
330i Coupe 3.0	E92	3.0	190	6	03.10-06.13	N52B30A	1,1	LZFR6AP11GS	95712		
330i Coupe 3.0	E92	3.0	200	6	09.06-	N52B30	1,1	ILZFR6D11	1208		
330i Coupe 3.0	E92	3.0	200	6	09.06-11.09	N52B30A, N52B30BF	1,1	ILZFR6D11	1208		
330i Coupe 3.0 Xi	E92	3.0	200	6	09.06-11.09	N52B30A	1,1	PLZFR6A-11S	5987		
330i Coupe 3.0	E92	3.0	200	6	09.06-11.09	N52B30A, N52B30BF	1,1	PLZFR6A-11S	5987		
330i Coupe 3.0 Xi	E92	3.0	200	6	09.06-02.10	N53B30A	0,5	ZKBR7A-HTU	91785		
330i Coupe 3.0	E92	3.0	200	6	09.06-06.13	N53B30A	0,5	ZKBR7A-HTU	91785		
330i Coupe 3.0	E92	3.0	200	6	09.07-	N53B30	0,5	ZKBR7A-HTU	91785		
330i Coupe 3.0 Xi	E92	3.0	200	6	01.09-02.10	N52B30A	1,1	LZFR6AP11GS	95712		
330i Coupe 3.0	E92	3.0	200	6	12.09-06.13	N52B30A, N52B30BF	1,1	LZFR6AP11GS	95712		





kW
C
Y
I



Stock-N°

VLINE

LPG/CNG

BMW

3 (SERIES) E93

320i Cabrio 2.0	E93	2.0	120	4	01.07-	N43B20A	0,5	ZKBR7A-HTU	91785		
320i Cabrio 2.0	E93	2.0	125	4	04.07-	N46B20	1,1	IZFR6H11	4294		
325i Cabrio 2.5	E93	2.5	160	6	12.06-11.09	N52B25A	1,1	PLZFR6A-11S	5987		
325i Cabrio 2.5	E93	2.5	160	6	01.10-	N52NB25A	1,1	LZFR6AP11GS	95712		
325i Cabrio 3.0	E93	3.0	155	6	03.07-	N53B30	0,5	ZKBR7A-HTU	91785		
325i Cabrio 3.0	E93	3.0	160	6	09.07-	N53B30	0,5	ZKBR7A-HTU	91785		
330i Cabrio 3.0	E93	3.0	200	6	03.07-11.09	N52B30A, N52B30BF	1,1	ILZFR6D11	1208		
330i Cabrio 3.0	E93	3.0	200	6	03.07-11.09	N52B30A, N52B30BF	1,1	PLZFR6A-11S	5987		
330i Cabrio 3.0	E93	3.0	200	6	04.07-	N52B30	1,1	ILZFR6D11	1208		
330i Cabrio 3.0	E93	3.0	200	6	09.07-	N53B30	0,5	ZKBR7A-HTU	91785		
330i Cabrio 3.0	E93	3.0	200	6	01.10-	N52NB30A, N52NB30B, N52NB30BF	1,1	LZFR6AP11GS	95712		

3 (SERIES) F30

318i 1.5	F30	1.5	100	3	07.15-	B38B15A	0,8	SILZKGR8B8S	94201		
320i 1.6	F30	1.6	125	4	10.12-	N13B16A	0,8	PLZKBR7B8G	91530		
320i xDrive 2.0	F30	2.0	135	4	11.11-	N20B20A	0,75	SILZKBR8D8S	97506		
320i 2.0	F30	2.0	135	4	01.12-	N20B20A, N20B20B	0,75	SILZKBR8D8S	97506		
320i 2.0	F30	2.0	135	4	07.15-	B48B20A	0,8	SILZKGR8B8S	94201		
320i xDrive 2.0	F30	2.0	135	4	07.15-	B48B20A	0,8	SILZKGR8B8S	94201		
328i 2.0	F30	2.0	180	4	10.11-	N20B20A, N26B20A	0,75	SILZKBR8D8S	97506		
328i xDrive 2.0	F30	2.0	180	4	10.11-	N20B20A	0,75	SILZKBR8D8S	97506		
330e 2.0 Hybrid	F30	2.0	135	4	01.16-	B48B20A	0,8	SILZKGR8B8S	94201		
330i 2.0	F30	2.0	185	4	07.15-	B46B20B, B48B20B	0,8	SILZKGR8B8S	94201		
330i xDrive 2.0	F30	2.0	185	4	07.15-	B48B20B	0,8	SILZKGR8B8S	94201		
340i 3.0	F30	3.0	240	6	07.15-	B58B30A	0,8	SILZKGR8B8S	94201		
340i xDrive 3.0	F30	3.0	240	6	07.15-	B58B30A	0,8	SILZKGR8B8S	94201		
340i 3.0 M Performance Power Kit	F30	3.0	265	6	10.15-	B58B30A	0,8	SILZKGR8B8S	94201		
340i xDrive 3.0 M Performance Power Kit	F30	3.0	265	6	10.15-	B58B30A	0,8	SILZKGR8B8S	94201		

3 (SERIES) F31

316i Touring 1.6	F31	1.6	100	4	11.12-	N13B16A	0,8	PLZKBR7B8G	91530		
318i Touring 1.5	F31	1.5	100	3	07.15-	B38B15A	0,8	SILZKGR8B8S	94201		
320i Touring 2.0	F31	2.0	135	4	06.12-	N20B20B	0,75	SILZKBR8D8S	97506		
320i xDrive Touring 2.0	F31	2.0	135	4	03.13-	N20B20A	0,75	SILZKBR8D8S	97506		
320i Touring 2.0	F31	2.0	135	4	07.15-	B48B20A	0,8	SILZKGR8B8S	94201		
320i xDrive Touring 2.0	F31	2.0	135	4	07.15-	B48B20A	0,8	SILZKGR8B8S	94201		
328i Touring 2.0	F31	2.0	180	4	06.12-	N20B20A	0,75	SILZKBR8D8S	97506		
328i xDrive Touring 2.0	F31	2.0	180	4	02.13-	N20B20A	0,75	SILZKBR8D8S	97506		
330i Touring 2.0	F31	2.0	185	4	07.15-	B48B20B	0,8	SILZKGR8B8S	94201		
330i xDrive Touring 2.0	F31	2.0	185	4	07.15-	B48B20B	0,8	SILZKGR8B8S	94201		
330i Touring 2.0	F31	2.0	185	4	07.15-06.19	B48B20B	0,8	SILZKGR8B8S	94201		
340i Touring 3.0	F31	3.0	240	6	07.15-	B58B30A	0,8	SILZKGR8B8S	94201		
340i xDrive Touring 3.0	F31	3.0	240	6	07.15-	B58B30A	0,8	SILZKGR8B8S	94201		
340i Touring 3.0	F31	3.0	240	6	07.15-06.19	B58B30A	0,8	SILZKGR8B8S	94201		
340i Touring 3.0 M Performance Power Kit	F31	3.0	265	6	07.15-	B58B30A	0,8	SILZKGR8B8S	94201		
340i xDrive Touring 3.0 M Performance Power Kit	F31	3.0	265	6	07.15-	B58B30A	0,8	SILZKGR8B8S	94201		





l kW C
Y
I



Stock-N°

VLINE

LPG/CNG

BMW

3 (SERIES) F34

320i Gran Turismo 2.0	F34	2.0	120	4	06.16-	B48B20A	0,8	SILZKGR8B8S	94201		
320i xDrive Gran Turismo 2.0	F34	2.0	120	4	07.16-	B48B20A	0,8	SILZKGR8B8S	94201		
320i Gran Turismo 2.0	F34	2.0	135	4	03.13-	N20B20A, N20B20B	0,75	SILZKBR8D8S	97506		
320i xDrive Gran Turismo 2.0	F34	2.0	135	4	07.13-	N20B20A	0,75	SILZKBR8D8S	97506		
320i Gran Turismo 2.0	F34	2.0	135	4	06.16-	B48B20A	0,8	SILZKGR8B8S	94201		
320i xDrive Gran Turismo 2.0	F34	2.0	135	4	06.16-	B48B20A	0,8	SILZKGR8B8S	94201		
328i Gran Turismo 2.0	F34	2.0	180	4	03.13-	N20B20A	0,75	SILZKBR8D8S	97506		
328i xDrive Gran Turismo 2.0	F34	2.0	180	4	07.13-	N20B20A	0,75	SILZKBR8D8S	97506		
330i xDrive Gran Turismo 2.0	F34	2.0	183	4	07.16-	B48B20B	0,8	SILZKGR8B8S	94201		
330i Gran Turismo 2.0	F34	2.0	185	4	06.16-	B48B20B	0,8	SILZKGR8B8S	94201		
330i xDrive Gran Turismo 2.0	F34	2.0	185	4	06.16-	B46B20B	0,8	SILZKGR8B8S	94201		
340i Gran Turismo 3.0	F34	3.0	240	6	06.16-	B58B30A	0,8	SILZKGR8B8S	94201		
340i xDrive Gran Turismo 3.0	F34	3.0	240	6	06.16-	B58B30A	0,8	SILZKGR8B8S	94201		
340i Gran Turismo 3.0 M Performance Power Kit	F34	3.0	265	6	07.16-	B58B30A	0,8	SILZKGR8B8S	94201		
340i xDrive Gran Turismo 3.0 M Performance Power Kit	F34	3.0	265	6	07.16-	B58B30A	0,8	SILZKGR8B8S	94201		

3 (SERIES) F92

316i 1.6	F30	1.6	100	4	08.12-	N13B16A	0,8	PLZKBR7B8G	91530		
----------	-----	-----	-----	---	--------	---------	-----	------------	-------	--	--

3 (SERIES) G20

320i 1.6	G20	1.6	125	4	03.19-	B48B16A	0,8	SILZKGR8B8S	94201		
----------	-----	-----	-----	---	--------	---------	-----	-------------	-------	--	--

4 (SERIES) F32

418i Coupe 1.5	F32	1.5	100	3	02.16-	B38B15A	0,8	SILZKGR8B8S	94201		
420i Coupe 2.0	F32	2.0	120	4	03.16-	B48B20A	0,8	SILZKGR8B8S	94201		
420i xDrive Coupe 2.0	F32	2.0	120	4	03.16-	B48B20A	0,8	SILZKGR8B8S	94201		
420i Coupe 2.0	F32	2.0	135	4	11.13-	N20B20A, N20B20B	0,75	SILZKBR8D8S	97506		
420i xDrive Coupe 2.0	F32	2.0	135	4	11.13-	N20B20B	0,75	SILZKBR8D8S	97506		
420i xDrive Coupe 2.0	F32	2.0	135	4	02.16-	B48B20A	0,8	SILZKGR8B8S	94201		
420i Coupe 2.0	F32	2.0	135	4	03.16-	B48B20A	0,8	SILZKGR8B8S	94201		
428i Coupe	F32	2.0	180	4	07.13-	N20B20A, N26B20A	0,75	SILZKBR8D8S	97506		
428i xDrive Coupe	F32	2.0	180	4	07.13-	N20B20A	0,75	SILZKBR8D8S	97506		
430i Coupe 2.0	F32	2.0	183	4	03.16-	B48B20B	0,8	SILZKGR8B8S	94201		
430i xDrive Coupe 2.0	F32	2.0	183	4	03.16-	B48B20B	0,8	SILZKGR8B8S	94201		
430i Coupe	F32	2.0	185	4	03.16-	B48B20B	0,8	SILZKGR8B8S	94201		
430i xDrive Coupe	F32	2.0	185	4	03.16-	B48B20B	0,8	SILZKGR8B8S	94201		
440i Coupe 3.0	F32	3.0	240	6	03.16-	B58B30A	0,8	SILZKGR8B8S	94201		
440i xDrive Coupe 3.0	F32	3.0	240	6	03.16-	B58B30A	0,8	SILZKGR8B8S	94201		
440i Coupe 3.0 M Performance Power Kit	F32	3.0	265	6	03.16-	B58B30A	0,8	SILZKGR8B8S	94201		
440i xDrive Coupe 3.0 M Performance Power Kit	F32	3.0	265	6	03.16-	B58B30A	0,8	SILZKGR8B8S	94201		

4 (SERIES) F33

420i Cabrio 2.0	F33	2.0	120	4	03.16-	B48B20A	0,8	SILZKGR8B8S	94201		
420i Cabrio 2.0	F33	2.0	135	4	07.14-	N20B20B	0,75	SILZKBR8D8S	97506		
420i Cabrio 2.0	F33	2.0	135	4	03.16-	B48B20A	0,8	SILZKGR8B8S	94201		
428i Cabrio	F33	2.0	180	4	10.13-	N20B20A, N26B20A	0,75	SILZKBR8D8S	97506		
428i xDrive Cabrio	F33	2.0	180	4	01.14-	N20B20A	0,75	SILZKBR8D8S	97506		
430i Cabrio	F33	2.0	185	4	03.16-	B48B20B	0,8	SILZKGR8B8S	94201		





kW
C
Y
I



Stock-N°

VLINE

LPG/CNG

BMW

4 (SERIES) F33

430i xDrive Cabrio	F33	2.0	185	4	03.16-	B48B20B	0,8	SILZKGR8B8S	94201		
440i Cabrio 3.0	F33	3.0	240	6	03.16-	B58B30A	0,8	SILZKGR8B8S	94201		
440i xDrive Cabrio 3.0	F33	3.0	240	6	03.16-	B58B30A	0,8	SILZKGR8B8S	94201		
440i Cabrio 3.0 M Performance Power Kit	F33	3.0	265	6	03.16-	B58B30A	0,8	SILZKGR8B8S	94201		
440i xDrive Cabrio 3.0 M Performance Power Kit	F33	3.0	265	6	03.16-	B58B30A	0,8	SILZKGR8B8S	94201		

4 (SERIES) F36

418i Gran Coupe 1.5	F36	1.5	100	3	06.15-	B38B15A	0,8	SILZKGR8B8S	94201		
420i Gran Coupe 2.0	F36	2.0	120	4	03.16-	B48B20A	0,8	SILZKGR8B8S	94201		
420i xDrive Gran Coupe 2.0	F36	2.0	120	4	03.16-	B48B20A	0,8	SILZKGR8B8S	94201		
420i Gran Coupe 2.0	F36	2.0	135	4	03.14-	N20B20B	0,75	SILZKBR8D8S	97506		
420i xDrive Gran Coupe 2.0	F36	2.0	135	4	07.14-	N20B20A	0,75	SILZKBR8D8S	97506		
420i xDrive Gran Coupe 2.0	F36	2.0	135	4	02.16-	B48B20A	0,8	SILZKGR8B8S	94201		
420i Gran Coupe 2.0	F36	2.0	135	4	03.16-	B48B20A	0,8	SILZKGR8B8S	94201		
428i Gran Coupe	F36	2.0	180	4	03.14-	N20B20A	0,75	SILZKBR8D8S	97506		
428i xDrive Gran Coupe	F36	2.0	180	4	03.14-	N20B20A	0,75	SILZKBR8D8S	97506		
430i xDrive Gran Coupe 2.0	F36	2.0	183	4	03.16-	B48B20B	0,8	SILZKGR8B8S	94201		
430i Gran Coupe	F36	2.0	185	4	03.16-	B48B20B	0,8	SILZKGR8B8S	94201		
430i xDrive Gran Coupe	F36	2.0	185	4	03.16-	B48B20B	0,8	SILZKGR8B8S	94201		
440i Gran Coupe 3.0	F36	3.0	240	6	03.16-	B58B30A	0,8	SILZKGR8B8S	94201		
440i xDrive Gran Coupe 3.0	F36	3.0	240	6	03.16-	B58B30A	0,8	SILZKGR8B8S	94201		
440i Gran Coupe 3.0 M Performance Power Kit	F36	3.0	265	6	03.16-	B58B30A	0,8	SILZKGR8B8S	94201		
440i xDrive Gran Coupe 3.0 M Performance Power Kit	F36	3.0	265	6	03.16-	B58B30A	0,8	SILZKGR8B8S	94201		

5 (SERIES) E34

518g Touring 1.8	E34	1.8	75	4	11.95-06.96	M43B18	0,9	BKR6EK	2288	20	LPG 1
518i 1.8	E34	1.8	83	4	09.89-04.94	M40B18	0,9	BKR6EK	2288	20	LPG 1
518i 1.8	E34	1.8	85	4	05.94-06.96	M43B18	0,9	BKR6EK	2288	20	LPG 1
520i 2.0	E34	2.0	95	6	01.88-08.91	M20B20	0,8	ZGR5A	5839	15	
520i 2.0	E34	2.0	110	6	03.89-06.96	M50B20	0,9	BKR6EK	2288	20	LPG 1
525i 2.5	E34	2.5	125	6	01.88-08.91	M20B25	0,8	ZGR5A	5839	15	
525i 2.5	E34	2.5	141	6	01.89-06.96	M50B25	0,9	BKR6EK	2288	20	LPG 1
525iX 2.5	E34	2.5	141	6	01.92-09.95	M50B25	0,9	BKR6EK	2288	20	LPG 1
525iX Touring 2.5	E34	2.5	141	6	01.92-09.96	M50B25	0,9	BKR6EK	2288	20	LPG 1
530i 3.0	E34	3.0	138	6	01.88-08.91	M30B30	0,8	ZGR5A	5839	15	
530i 3.0	E34	3.0	155	8	04.92-06.96	M60B30	0,9	BKR6EK	2288	20	LPG 1
535i 3.5	E34	3.5	155	6	01.88-08.92	M30B35	0,8	ZGR5A	5839	15	
540i 4.0	E34	4.0	210	8	03.92-06.96	M60B40	0,9	BKR6EK	2288	20	LPG 1

5 (SERIES) E39

520i 2.0	E39	2.0	110	6	01.96-08.98	M52B20	0,9	BKR6EK	2288	20	LPG 1
520i Touring 2.0	E39	2.0	110	6	03.97-08.98	M52B20	0,9	BKR6EK	2288	20	LPG 1
520i 2.0	E39	2.0	110	6	09.98-06.03	M52B20	1,5	BKR6EQU	3199	30	LPG 1
520i Touring 2.0	E39	2.0	110	6	09.98-07.01	M52B20	1,5	BKR6EQU	3199	30	LPG 1
520i 2.2	E39	2.2	120	6	09.00-06.03	M54B226S1	1,5	BKR6EQU	3199	30	LPG 1
520i Touring 2.2	E39	2.2	120	6	09.00-12.03	M54B226S1	1,5	BKR6EQU	3199	30	LPG 1
520i Touring 2.2	E39	2.2	125	6	04.00-12.03	M54B22	1,5	BKR6EQU	3199	30	LPG 1





l kW C
Y
I



Stock-N°

VLINE

LPG/CNG

BMW

5 (SERIES) E39

520i 2.2	E39	2.2	125	6	08.00-06.03	M54B22	1,5	BKR6EQUP	3199	30	LPG 1
520i 2.2	E39	2.2	125	6	08.00-09.03	M54B22	1,5	BKR6EQUP	3199	30	LPG 1
520i Touring 2.2	E39	2.2	125	6	08.00-05.04	M54B22	1,5	BKR6EQUP	3199	30	LPG 1
523i Touring 2.5	E39	2.5	120	6	06.96-09.98	M52B256S3	0,9	BKR6EK	2288	20	LPG 1
523i 2.5	E39	2.5	125	6	12.95-08.98	M52B25	0,9	BKR6EK	2288	20	LPG 1
523i Touring 2.5	E39	2.5	125	6	03.97-08.98	M52B25	0,9	BKR6EK	2288	20	LPG 1
523i 2.5	E39	2.5	125	6	09.98-12.00	M52B25	1,5	BKR6EQUP	3199	30	LPG 1
523i Touring 2.5	E39	2.5	125	6	09.98-12.00	M52B25	1,5	BKR6EQUP	3199	30	LPG 1
525i 2.5	E39	2.5	141	6	11.99-11.03	M54B25	1,5	BKR6EQUP	3199	30	LPG 1
525i Touring 2.5	E39	2.5	141	6	04.00-12.03	M54B25	1,5	BKR6EQUP	3199	30	LPG 1
528i 2.8	E39	2.8	142	6	12.95-08.98	M52B28	0,9	BKR6EK	2288	20	LPG 1
528i Touring 2.8	E39	2.8	142	6	03.97-08.98	M52B28	0,9	BKR6EK	2288	20	LPG 1
528i 2.8	E39	2.8	142	6	09.98-11.00	M52B28	1,5	BKR6EQUP	3199	30	LPG 1
528i Touring 2.8	E39	2.8	142	6	09.98-12.00	M52B28	1,5	BKR6EQUP	3199	30	LPG 1
530i Touring 3.0	E39	3.0	170	6	11.99-12.03	M54B30	1,5	BKR6EQUP	3199	30	LPG 1
530i 3.0	E39	3.0	170	6	04.00-06.03	M54B30	1,5	BKR6EQUP	3199	30	LPG 1
535i 3.5	E39	3.5	180	8	06.96-08.98	M62B35	0,9	BKR6EK	2288	20	LPG 1
535i 3.5	E39	3.5	180	8	09.98-09.03	M62B35	1,5	BKR6EQUP	3199	30	LPG 1
535i 3.5	E39	3.5	180	8	09.98-06.03	M62B358S2	0,9	BKR6EK	2288	20	LPG 1
540i 4.4	E39	4.4	210	8	04.96-08.98	M62B44	0,9	BKR6EK	2288	20	LPG 1
540i Touring 4.4	E39	4.4	210	8	03.97-08.98	M62B44	0,9	BKR6EK	2288	20	LPG 1
540i 4.4	E39	4.4	210	8	09.98-11.03	M62B44	1,5	BKR6EQUP	3199	30	LPG 1
540i Touring 4.4	E39	4.4	210	8	09.98-12.03	M62B44	1,5	BKR6EQUP	3199	30	LPG 1

5 (SERIES) E60

520i 2.0	E60	2.0	120	4	09.07-08.10	N43B20A	0,5	ZKBR7A-HTU	91785		
520i 2.0	E60	2.0	125	4	05.07-03.10	N43B20	0,5	ZKBR7A-HTU	91785		
520i 2.2	E60	2.2	125	6	02.02-02.05	M54B22	1,5	BKR6EQUP	3199	30	LPG 1
523i 2.5	E60	2.5	130	6	10.04-02.07	N52B25A, N52B25B, N52B25BE	1,1	PLZFR6A-11S	5987		
523i 2.5	E60	2.5	140	6	02.07-03.10	N52B25A, N53B25A	0,5	ZKBR7A-HTU	91785		
523i 2.5	E60	2.5	140	6	03.07-12.09	N52B25A, N52B25BE	1,1	ILZFR6D11	1208		
523i 2.5	E60	2.5	140	6	03.07-12.09	N52B25A, N52B25BE	1,1	PLZFR6A-11S	5987		
525i 2.5	E60	2.5	141	6	09.03-12.04	M54B25	1,5	BKR6EQUP	3199	30	LPG 1
525i 2.5	E60	2.5	155	6	07.05-11.09	N52B25A	1,1	ILZFR6D11	1208		
525i 2.5	E60	2.5	155	6	07.05-11.09	N52B25A	1,1	PLZFR6A-11S	5987		
525i 2.5	E60	2.5	155	6	12.09-03.10	N52B25A	1,1	LZFR6AP11GS	95712		
525i 2.5	E60	2.5	160	6	03.05-03.10	N52B25A, N52B25B, N52B25BF, N52NB25A	1,1	LZFR6AP11GS	95712		
525i 2.5	E60	2.5	160	6	03.05-12.09	N52B25A, N52B25B, N52B25BF	1,1	PLZFR6A-11S	5987		
525i 2.5 Xi	E60	2.5	160	6	04.05-02.07	N52B25A	1,1	PLZFR6A-11S	5987		
525i 2.5	E60	2.5	160	6	03.07-	N53B25	0,5	ZKBR7A-HTU	91785		
525i 3.0	E60	3.0	155	6	01.07-03.10	N53B30A	0,5	ZKBR7A-HTU	91785		
530i 3.0	E60	3.0	170	6	07.03-12.04	M54B30	1,5	BKR6EQUP	3199	30	LPG 1
530i 3.0 Xi	E60	3.0	190	6	09.04-02.07	N52B30A	1,1	PLZFR6A-11S	5987		
530i 3.0	E60	3.0	190	6	10.04-	N52B30	1,1	ILZFR6D11	1208		
530i 3.0	E60	3.0	190	6	03.05-03.07	N52B30A, N52B30BF	1,1	PLZFR6A-11S	5987		





l kW C
Y
I



Stock-N°

VLINE

LPG/CNG

BMW

5 (SERIES) E60

530i 3.0	E60	3.0	200	6	01.07-	N53B30	0,5	ZKBR7A-HTU	91785		
530i 3.0 Xi	E60	3.0	200	6	02.07-10.09	N52B30A	1,1	ILZFR6D11	1208		
530i 3.0 Xi	E60	3.0	200	6	02.07-10.09	N52B30A	1,1	PLZFR6A-11S	5987		
530i 3.0	E60	3.0	200	6	03.07-12.09	N52B30A, N52B30BF	1,1	ILZFR6D11	1208		
530i 3.0	E60	3.0	200	6	03.07-12.09	N52B30A, N52B30BF	1,1	PLZFR6A-11S	5987		
530i xDrive 3.0	E60	3.0	200	6	09.08-12.09	N53B30A	0,5	ZKBR7A-HTU	91785		
540i 4.0	E60	4.0	225	8	10.05-11.09	N62B40	1,1	IZFR6H11	4294		
545i 4.4	E60	4.4	245	8	09.03-10.05	N62B44	1,5	BKR6EQUP	3199	30	LPG 1
550i 4.8	E60	4.8	270	8	02.05-	N62B48	1,1	IZFR6H11	4294		

5 (SERIES) E61

520i Touring 2.0	E61	2.0	120	4	09.07-08.10	N43B20A	0,5	ZKBR7A-HTU	91785		
520i Touring 2.0	E61	2.0	125	4	09.07-05.10	N43B20A	0,5	ZKBR7A-HTU	91785		
523i Touring 2.5	E61	2.5	130	6	10.04-02.07	N52B25A, N52B25B, N52B25BE	1,1	LZFR6AP11GS	95712		
523i Touring 2.5	E61	2.5	130	6	03.05-12.10	N52B25A, N52B25B, N52B25BE, N52NB25A	1,1	LZFR6AP11GS	95712		
523i Touring 2.5	E61	2.5	140	6	03.07-03.10	N53B25	0,5	ZKBR7A-HTU	91785		
525i Touring 2.5	E61	2.5	141	6	05.04-12.04	M54B25	1,5	BKR6EQUP	3199	30	LPG 1
525i Touring 2.5	E61	2.5	155	6	03.05-11.09	N52B25A	1,1	ILZFR6D11	1208		
525i Touring 2.5	E61	2.5	155	6	03.05-11.09	N52B25A	1,1	PLZFR6A-11S	5987		
525i Touring 2.5	E61	2.5	155	6	12.09-05.10	N52B25A	1,1	LZFR6AP11GS	95712		
525i Touring 2.5	E61	2.5	160	6	10.04-11.09	N52B25A, N52B25B, N52B25BF	1,1	PLZFR6A-11S	5987		
525i Touring 2.5 Xi	E61	2.5	160	6	03.05-02.07	N52B25A	1,1	PLZFR6A-11S	5987		
525i Touring 2.5	E61	2.5	160	6	03.07-	N53B25	0,5	ZKBR7A-HTU	91785		
525i Touring 2.5	E61	2.5	160	6	12.09-05.10	N52B25A, N52B25B, N52B25BF	1,1	LZFR6AP11GS	95712		
525i Touring 3.0	E61	3.0	155	6	01.07-12.10	N53B30A	0,5	ZKBR7A-HTU	91785		
530i Touring 3.0	E61	3.0	190	6	09.04-02.07	N52B30A, N52B30BF	1,1	PLZFR6A-11S	5987		
530i Touring 3.0 Xi	E61	3.0	190	6	04.05-02.07	N52B30A	1,1	PLZFR6A-11S	5987		
530i Touring 3.0	E61	3.0	190	6	10.05-	N52B30	1,1	ILZFR6D11	1208		
530i Touring 3.0 Xi	E61	3.0	200	6	09.06-09.08	N53B30A	0,5	ZKBR7A-HTU	91785		
530i Touring 3.0	E61	3.0	200	6	01.07-	N53B30	0,5	ZKBR7A-HTU	91785		
530i Touring 3.0	E61	3.0	200	6	01.07-11.09	N52B30A	1,1	ILZFR6D11	1208		
530i Touring 3.0	E61	3.0	200	6	01.07-11.09	N52B30A	1,1	PLZFR6A-11S	5987		
530i Touring 3.0	E61	3.0	200	6	12.09-12.10	N52B30A	1,1	LZFR6AP11GS	95712		
545i Touring 4.4	E61	4.4	245	8	05.04-08.05	N62B44	1,5	BKR6EQUP	3199	30	LPG 1
550i Touring 4.8	E61	4.8	270	8	02.05-	N62B48	1,1	IZFR6H11	4294		

5 (SERIES) F10

520i 1.6	F10	1.6	125	4	08.13-	N20B16A	0,75	SILZKBR8D8S	97506		
520i 2.0	F10	2.0	120	4	09.11-	N20B20A, N20B20B	0,75	SILZKBR8D8S	97506		
520i 2.0	F10	2.0	120	4	04.15-	N20B20A, N20B20B	0,75	SILZKBR8D8S	97506		
520i 2.0	F10	2.0	135	4	09.11-	N20B20A, N20B20B	0,75	SILZKBR8D8S	97506		
520i 2.0	F10	2.0	135	4	04.15-	N20B20A, N20B20B	0,75	SILZKBR8D8S	97506		
523i 2.5	F10	2.5	150	6	03.10-	N52NB25A	1,1	LZFR6AP11GS	95712		
523i 3.0	F10	3.0	150	6	03.10-06.13	N53B30	0,5	ZKBR7A-HTU	91785		
523i 3.0	F10	3.0	155	6	01.10-08.11	N53B30A	0,5	ZKBR7A-HTU	91785		
528i 2.0	F10	2.0	180	4	09.11-	N20B20A	0,75	SILZKBR8D8S	97506		





e kW C
Y
I



Stock-N°

VLINE

LPG/CNG

BMW

5 (SERIES) F10

528i xDrive 2.0	F10	2.0	180	4	09.11-	N20B20A	0,75	SILZKBR8D8S	97506		
528i 2.0	F10	2.0	180	4	04.15-	N20B20A	0,75	SILZKBR8D8S	97506		
528i xDrive 2.0	F10	2.0	180	4	04.15-	N20B20A	0,75	SILZKBR8D8S	97506		
528i 3.0	F10	3.0	190	6	03.10-	N52NB30A	1,1	LZFR6AP11GS	95712		
528i 3.0	F10	3.0	190	6	03.10-	N53B30	0,5	ZKBR7A-HTU	91785		
530i 3.0	F10	3.0	190	6	03.10-06.13	N52B30A, N52B30AF, N52B30BF	1,1	PLZFR6A-11S	5987		
530i 3.0	F10	3.0	200	6	09.11-07.13	N52NB30A, N52NB30BF	1,1	LZFR6AP11GS	95712		

5 (SERIES) F11

520i Touring 2.0	F11	2.0	135	4	09.11-	N20B20A, N20B20B	0,75	SILZKBR8D8S	97506		
520i Touring 2.0	F11	2.0	135	4	04.15-	N20B20A, N20B20B	0,75	SILZKBR8D8S	97506		
523i Touring 2.5	F11	2.5	150	6	11.09-11.09	N52B25A, N52B25AF, N52B25B	1,1	PLZFR6A-11S	5987		
523i Touring 2.5	F11	2.5	150	6	04.10-12.11	N52NB25A	1,1	LZFR6AP11GS	95712		
523i Touring 3.0	F11	3.0	150	6	08.10-12.11	N53B30	0,5	ZKBR7A-HTU	91785		
528i Touring 2.0	F11	2.0	180	4	09.11-	N20B20A	0,75	SILZKBR8D8S	97506		
528i xDrive Touring 2.0	F11	2.0	180	4	09.11-	N20B20A	0,75	SILZKBR8D8S	97506		
528i Touring 2.0	F11	2.0	180	4	04.15-	N20B20A	0,75	SILZKBR8D8S	97506		
528i xDrive Touring 2.0	F11	2.0	180	4	04.15-	N20B20A	0,75	SILZKBR8D8S	97506		
530i Touring 3.0	F11	3.0	190	6	03.10-06.13	N52B30A, N52B30AF	1,1	PLZFR6A-11S	5987		
530i Touring 3.0	F11	3.0	200	6	07.11-06.13	N53B30A	0,5	ZKBR7A-HTU	91785		
530i Touring 3.0	F11	3.0	200	6	09.11-07.13	N52NB30A, N52NB30AF	1,1	LZFR6AP11GS	95712		

5 (SERIES) G30

520i 1.6	G30	1.6	125	4	07.17-	B48B16A	0,8	SILZKGR8B8S	94201		
520i 2.0	G30	2.0	120	4	07.17-06.18	B48B20A	0,8	SILZKGR8B8S	94201		
520i 2.0	G30	2.0	135	4	07.17-06.18	B48B20A	0,8	SILZKGR8B8S	94201		
520i 2.0 M Performance Power Kit	G30	2.0	155	4	07.17-06.18	B48B20A	0,8	SILZKGR8B8S	94201		
530e 2.0 Plug-In Hybrid	G30	2.0	120	4	07.19-	B48B20A	0,8	SILZKGR8B8S	94201		
530e xDrive 2.0 Plug-In Hybrid	G30	2.0	120	4	07.19-	B48B20A	0,8	SILZKGR8B8S	94201		
530e 2.0 Plug-In Hybrid	G30	2.0	135	4	03.17-	B46B20B, B48B20A	0,8	SILZKGR8B8S	94201		
530e xDrive 2.0 Plug-In Hybrid	G30	2.0	135	4	07.19-	B48B20A	0,8	SILZKGR8B8S	94201		
530i xDrive 2.0	G30	2.0	183	4	09.16-06.19	B46B20B	0,8	SILZKGR8B8S	94201		
530i 2.0	G30	2.0	185	4	09.16-	B46B20B, B48B20B	0,8	SILZKGR8B8S	94201		
530i xDrive 2.0	G30	2.0	185	4	09.16-	B46B20B, B48B20B	0,8	SILZKGR8B8S	94201		
540i 3.0	G30	3.0	250	6	09.16-	B58B30A	0,8	SILZKGR8B8S	94201		
540i xDrive 3.0	G30	3.0	250	6	09.16-	B58B30A	0,8	SILZKGR8B8S	94201		
540i 3.0 Performance Power Kit	G30	3.0	265	6	09.16-	B58B30A	0,8	SILZKGR8B8S	94201		
540i xDrive 3.0 Performance Power Kit	G30	3.0	265	6	09.16-	B58B30A	0,8	SILZKGR8B8S	94201		

5 (SERIES) G31

520i Touring 2.0	G31	2.0	120	4	07.17-06.18	B48B20A	0,8	SILZKGR8B8S	94201		
520i Touring 2.0	G31	2.0	135	4	07.17-06.18	B48B20A	0,8	SILZKGR8B8S	94201		
520i Touring 2.0 M Performance Power Kit	G31	2.0	155	4	07.17-06.18	B48B20A	0,8	SILZKGR8B8S	94201		
530i Touring 2.0	G31	2.0	185	4	03.17-06.18	B48B20B	0,8	SILZKGR8B8S	94201		
530i xDrive Touring 2.0	G31	2.0	185	4	07.17-06.18	B48B20B	0,8	SILZKGR8B8S	94201		
540i xDrive Touring 3.0	G31	3.0	250	6	03.17-06.20	B58B30A	0,8	SILZKGR8B8S	94201		
540i xDrive Touring 3.0	G31	3.0	250	6	03.17-	B58B30A	0,8	SILZKGR8B8S	94201		





l kW
C
Y
I



Stock-N°

VLINE

LPG/CNG

BMW

5 (SERIES) G31

540i xDrive Touring 3.0 M Performance Power Kit	G31	3.0	265	6	03.17-06.20	B58B30A	0,8	SILZKGR8B8S	94201		
---	-----	-----	-----	---	-------------	---------	-----	-------------	-------	--	--

6 (SERIES) E63

630Ci 3.0	E63	3.0	190	6	02.04-	N52B30	1,1	ILZFR6D11	1208		
630Ci 3.0	E63	3.0	200	6	03.07-05.10	N53B30	0,5	ZKBR7A-HTU	91785		
630i Coupe 3.0	E63	3.0	190	6	09.04-08.07	N52B30A, N52B30BF	1,1	PLZFR6A-11S	5987		
630i Coupe 3.0	E63	3.0	190	6	12.09-12.11	N52B30A, N52B30BF	1,1	LZFR6AP11GS	95712		
630i Coupe 3.0	E63	3.0	200	6	09.07-08.10	N52B30A, N52B30B, N52B30BF	1,1	ILZFR6D11	1208		
630i Coupe 3.0	E63	3.0	200	6	09.07-08.10	N52B30A, N52B30B, N52B30BF	1,1	PLZFR6A-11S	5987		
635Ci 3.6	E63	3.6	200	8	09.04-	N62B36	1,5	BKR6EQUP	3199	30	LPG 1
645Ci 4.4	E63	4.4	245	8	09.02-08.05	N62B44	1,5	BKR6EQUP	3199	30	LPG 1
650Ci 4.8	E63	4.8	270	8	10.05-	N62B48	1,1	IZFR6H11	4294		

6 (SERIES) E64

630Ci Cabrio 3.0	E64	3.0	190	6	09.04-	N52B30	1,1	ILZFR6D11	1208		
630Ci Cabrio 3.0	E64	3.0	200	6	03.07-02.11	N53B30	0,5	ZKBR7A-HTU	91785		
630i Cabrio 3.0	E64	3.0	190	6	09.04-08.07	N52B30A, N52B30B, N52B30BF	1,1	ILZFR6D11	1208		
630i Cabrio 3.0	E64	3.0	190	6	09.04-08.07	N52B30A, N52B30B, N52B30BF	1,1	PLZFR6A-11S	5987		
630i Cabrio 3.0	E64	3.0	190	6	12.09-12.11	N52B30A, N52B30B, N52B30BF	1,1	LZFR6AP11GS	95712		
630i Cabrio 3.0	E64	3.0	200	6	09.07-11.09	N52B30A, N52B30B, N52B30BF	1,1	ILZFR6D11	1208		
630i Cabrio 3.0	E64	3.0	200	6	09.07-11.09	N52B30A, N52B30B, N52B30BF	1,1	PLZFR6A-11S	5987		
630i Cabrio 3.0	E64	3.0	200	6	12.09-08.10	N52B30A, N52B30B, N52B30BF	1,1	LZFR6AP11GS	95712		
645Ci Cabrio 4.4	E64	4.4	245	8	02.04-09.05	N62B44	1,5	BKR6EQUP	3199	30	LPG 1
650Ci Cabrio 4.8	E64	4.8	270	8	03.05-	N62B48	1,1	IZFR6H11	4294		

6 (SERIES) G32

630i Gran Turismo 2.0	G32	2.0	183	4	06.17-06.19	B48B20B	0,8	SILZKGR8B8S	94201		
630i Gran Turismo 2.0	G32	2.0	190	4	06.17-06.20	B48B20B	0,8	SILZKGR8B8S	94201		
640i Gran Turismo 3.0	G32	3.0	250	6	06.17-06.20	B58B30A	0,8	SILZKGR8B8S	94201		
640i xDrive Gran Turismo 3.0	G32	3.0	250	6	06.17-06.20	B58B30A	0,8	SILZKGR8B8S	94201		
640i xDrive Gran Turismo 3.0	G32	3.0	250	6	06.17-	B58B30C	0,8	SILZKGR8B8S	94201		
640i Gran Turismo 3.0	G32	3.0	265	6	06.17-	B58B30A	0,8	SILZKGR8B8S	94201		
640i xDrive Gran Turismo 3.0	G32	3.0	265	6	06.17-	B58B30A, B58B30C	0,8	SILZKGR8B8S	94201		

7 (SERIES) E32

730i 3.0	E32	3.0	136	6	09.86-08.92	M30B30	0,8	ZGR5A	5839	15	
730i 3.0	E32	3.0	160	8	04.92-09.94	M60B30	0,9	BKR6EK	2288	20	LPG 1
735i 3.4	E32	3.4	155	6	09.86-07.92	M30B35	0,8	ZGR5A	5839	15	
740i 4.0	E32	4.0	210	8	04.92-09.94	M60B40	0,9	BKR6EK	2288	20	LPG 1
750i 5.0	E32	5.0	220	12	09.87-09.94	M70B50	0,8	ZFR5F	5165	53	LPG 6

7 (SERIES) E38

728i 2.8	E38	2.8	142	6	09.95-08.98	M52B28	0,9	BKR6EK	2288	20	LPG 1
728i 2.8	E38	2.8	142	6	09.98-11.01	M52B28	1,5	BKR6EQUP	3199	30	LPG 1
730i 3.0	E38	3.0	160	8	09.94-09.95	M60B30	0,9	BKR6EK	2288	20	LPG 1
735i 3.5	E38	3.5	175	8	03.96-08.98	M62B35	0,9	BKR6EK	2288	20	LPG 1
735i 3.5	E38	3.5	175	8	09.98-	M62B35	1,5	BKR6EQUP	3199	30	LPG 1





l kW C
y
i



Stock-N°

VLINE

LPG/CNG

BMW

7 (SERIES) E38

740i 4.0	E38	4.0	210	8	09.94-05.95	M60B40	0,9	BKR6EK	2288	20	LPG 1
740i 4.4	E38	4.4	210	8	05.95-08.98	M62B44	0,9	BKR6EK	2288	20	LPG 1
740i 4.4 -/iL	E38	4.4	210	8	02.96-07.01	M62B448S1	0,9	BKR6EK	2288	20	LPG 1
740i 4.4	E38	4.4	210	8	09.99-11.01	M62B44	1,5	BKR6EQUP	3199	30	LPG 1
750i 5.4	E38	5.4	240	12	11.94-	M73B54	1,5	BKR6EQUP	3199	30	LPG 1

7 (SERIES) E65

730i 3.0	E65	3.0	170	6	10.02-02.05	M54B30	1,5	BKR6EQUP	3199	30	LPG 1
730i 3.0	E65	3.0	190	6	03.05-	N52B30	1,1	ILZFR6D11	1208		
730i 3.0	E65	3.0	190	6	03.05-08.08	N52B30A, N52B30BF	1,1	ILZFR6D11	1208		
730i 3.0	E65	3.0	190	6	03.05-08.08	N52B30A, N52B30BF	1,1	PLZFR6A-11S	5987		
735i 3.6	E65	3.6	200	8	07.01-02.05	N62B36	1,5	BKR6EQUP	3199	30	LPG 1
740i 4.0	E65	4.0	225	8	01.05-11.09	N62B40	1,1	IZFR6H11	4294		
745i 4.4	E65	4.4	245	8	07.01-02.05	N62B44	1,5	BKR6EQUP	3199	30	LPG 1
750i 4.8	E65	4.8	270	8	01.05-	N62B48	1,1	IZFR6H11	4294		
760i 6.0	E65	6.0	327	12	01.03-	N73B60	1,5	BKR6EQUP	3199	30	LPG 1

7 (SERIES) E66

730i 3.0 Li	E66	3.0	190	6	03.05-08.08	N52B30A, N52B30BF	1,1	ILZFR6D11	1208		
730i 3.0 Li	E66	3.0	190	6	03.05-08.08	N52B30A, N52B30BF	1,1	PLZFR6A-11S	5987		

7 (SERIES) F01

730i 3.0	F01	3.0	190	6	09.09-12.09	N52B30A, N52B30AF, N52B30BF	1,1	ILZFR6D11	1208		
730i 3.0	F01	3.0	190	6	09.09-12.09	N52B30A, N52B30AF, N52B30BF	1,1	PLZFR6A-11S	5987		
730i 3.0	F01	3.0	190	6	01.10-08.15	N52B30A, N52B30AF, N52B30BF	1,1	LZFR6AP11GS	95712		
750i 4.4	F01	4.4	300	8	10.08-	N63B44	0,8	SIZKBR8A8HS	1555		

7 (SERIES) F02

730i 3.0 Li	F02	3.0	190	6	06.09-12.09	N52B30A, N52B30AF, N52B30BF	1,1	ILZFR6D11	1208		
730i 3.0 Li	F02	3.0	190	6	06.09-12.09	N52B30A, N52B30AF, N52B30BF	1,1	PLZFR6A-11S	5987		
730i 3.0 Li	F02	3.0	190	6	01.10-08.15	N52B30A, N52B30AF, N52B30BF	1,1	LZFR6AP11GS	95712		

7 (SERIES) G11

730i 2.0	G11	2.0	183	4	11.15-02.19	B48B20B	0,8	SILZKGR8B8S	94201		
730i 2.0	G11	2.0	190	4	02.16-	B48B20B	0,8	SILZKGR8B8S	94201		
740e 2.0 Hybrid	G11	2.0	190	4	04.16-	B48B20B	0,8	SILZKGR8B8S	94201		
740i 3.0	G11	3.0	240	6	09.15-	B58B30A	0,8	SILZKGR8B8S	94201		

7 (SERIES) G12

740i xDrive 3.0	G12	3.0	240	6	03.16-	B58B30A	0,8	SILZKGR8B8S	94201		
740e 2.0 Hybrid	G12	2.0	190	4	04.16-	B48B20B	0,8	SILZKGR8B8S	94201		
740e xDrive 2.0 Hybrid	G12	2.0	190	4	04.16-	B48B20B	0,8	SILZKGR8B8S	94201		

8 (SERIES) E31

840Ci 4.0	E31	4.0	210	8	12.93-02.96	M60B40	0,9	BKR6EK	2288	20	LPG 1
840Ci 4.4	E31	4.4	210	8	03.96-05.99	M62B44	0,9	BKR6EK	2288	20	LPG 1
850Ci 5.0	E31	5.0	220	12	05.89-10.94	M70B50	0,8	ZFR5F	5165	53	LPG 6
850Ci 5.4	E31	5.4	240	12	10.94-05.99	M73B54	1,5	BKR6EQUP	3199	30	LPG 1
850Csi 5.6	E31	5.6	280	12	02.93-11.96	S70B56	0,8	ZFR5F	5165	53	LPG 6





l kW
C
Y
I



Stock-N°

VLINE

LPG/CNG

BMW

I8 (SERIES) I12

i8 1.5 Hybrid	I12	1.5	170	3	03.14-	B38K15A	0,8	SILZKGR8C8S	95248		
----------------------	------------	-----	-----	---	--------	---------	-----	--------------------	--------------	--	--

M3 / M5 / M6 (SERIES)

M3 3.2	E36	3.2	236	6	11.95-10.99	S50B32	0,7	PKR7A	3641		
M3 3.2	E46	3.2	252	6	07.99-08.06	S54B32	0,9	DCPR8EKP	7415		
M3 CSL 3.2	E46	3.2	265	6	09.02-12.03	S54B32	0,9	DCPR8EKP	7415		
M3 4.0	E92	4.0	309	8	03.07-	S65B40	0,9	LKR8AP	4471		
M3 4.0	E90	4.0	309	8	09.07-	S65B40	0,9	LKR8AP	4471		
M3 4.0	E93	4.0	309	8	09.07-	S65B40	0,9	LKR8AP	4471		
M5 5.0	E39	5.0	294	8	09.98-07.03	S62B50	1,5	BKR6EQUP	3199	30	LPG 1
M5 5.0	E60	5.0	373	10	11.04-	S85B50	0,9	LKR8AP	4471		
M5 Touring 5.0	E61	5.0	373	10	03.07-04.10	S85B50A	0,9	LKR8AP	4471		
M6 5.0	E63	5.0	373	10	09.04-	S85B50	0,9	LKR8AP	4471		
M6 Cabrio 5.0	E64	5.0	373	10	07.05-	S85B50	0,9	LKR8AP	4471		

X1 (SERIES) E84

X1 sDrive 16i 1.6	E84	1.6	105	4	03.13-	N20B16A	0,75	SILZKBR8D8S	97506		
X1 xDrive 18i 2.0	E84	2.0	110	4	09.08-	N46B20	1,1	IZFR6H11	4294		
X1 sDrive 20i 2.0	E84	2.0	135	4	09.11-	N20B20A	0,75	SILZKBR8D8S	97506		
X1 xDrive 20i 2.0	E84	2.0	135	4	09.11-	N20B20A	0,75	SILZKBR8D8S	97506		
X1 xDrive 28i 2.0	E84	2.0	180	4	04.11-	N20B20A	0,75	SILZKBR8D8S	97506		
X1 xDrive 25i 3.0	E84	3.0	160	6	01.10-12.12	N52B30A	1,1	LZFR6AP11GS	95712		
X1 xDrive 28i 3.0	E84	3.0	190	6	09.09-12.09	N52B30A	1,1	ILZFR6D11	1208		
X1 xDrive 28i 3.0	E84	3.0	190	6	09.09-12.09	N52B30A	1,1	PLZFR6A-11S	5987		
X1 xDrive 28i 3.0	E84	3.0	190	6	01.10-06.15	N52NB30A	1,1	LZFR6AP11GS	95712		
X1 xDrive 28i 3.0	E84	3.0	194	6	03.10-06.11	N52B30A	1,1	LZFR6AP11GS	95712		

X1 (SERIES) F48

X1 sDrive 20i 2.0	F48	2.0	141	4	09.15-	B48A20A	0,8	SILZKGR8B8S	94201		
X1 xDrive 20i 2.0	F48	2.0	141	4	09.15-	B48A20B	0,8	SILZKGR8B8S	94201		
X1 xDrive 25i 2.0	F48	2.0	170	4	09.15-	B48A20B	0,8	SILZKGR8B8S	94201		

X2 (SERIES) F39

X2 sDrive 18i 1.5	F39	1.5	100	3	03.18-	B32S15A	0,8	SILZKGR8B8S	94201		
X2 sDrive 20i 2.0	F39	2.0	141	4	11.17-	B42S20A	0,8	SILZKGR8B8S	94201		

X3 (SERIES) E70

X3si xDrive 30i 3.0	E70	3.0	200	6	12.09-06.10	N52B30A	1,1	LZFR6AP11GS	95712		
X5 M 4.4	E70	4.4	408	8	06.09-10.13	S63B44A	0,75	SILZKBR8D8S	97506		

X3 (SERIES) E83

X3 xDrive 20i 2.0	E83	2.0	110	4	09.05-	N46B20	1,1	IZFR6H11	4294		
X3 xDrive 20i 2.0	E83	2.0	110	4	09.08-08.11	N46B20B	1,1	IZFR6H11	4294		
X3 xDrive 25i	E83	2.5	141	6	01.04-	M54B25	1,5	BKR6EQUP	3199	30	LPG 1
X3si 2.5	E83	2.5	155	6	08.06-08.08	N52B25A, N52B25AF, N52B25BF	1,1	ILZFR6D11	1208		
X3 xDrive 25i 2.5	E83	2.5	155	6	09.08-12.09	N52B25A, N52B25AF, N52B25BF	1,1	ILZFR6D11	1208		
X3 xDrive 25i 2.5	E83	2.5	155	6	09.08-12.09	N52B25A, N52B25AF, N52B25BF	1,1	PLZFR6A-11S	5987		
X3 xDrive 25i Si	E83	2.5	155	6	01.10-12.11	N52B25A, N52B25B, N52B25BF	1,1	LZFR6AP11GS	95712		
X3 xDrive 25i 2.5	E83	2.5	155	6	01.10-08.10	N52B25A, N52B25AF, N52B25BF	1,1	LZFR6AP11GS	95712		



e kW C
Y I

Stock-N°

VLINE

LPG/CNG

BMW**X3 (SERIES) E83**

X3 xDrive 25i 2.5	E83	2.5	160	6	09.08-12.09	N52B25A, N52B25AF, N52B25BF	1,1	ILZFR6D11	1208		
X3 xDrive 25i Si	E83	2.5	160	6	01.10-12.11	N52B25A, N52B25B, N52B25BF	1,1	LZFR6AP11GS	95712		
X3 xDrive 30 3.0	E83	3.0	170	6	01.04-	M54B30	1,5	BKR6EQUP	3199	30	LPG 1
X3 xDrive 30 3.0	E83	3.0	200	6	06.06-	N52B30	1,1	ILZFR6D11	1208		
X3si 3.0	E83	3.0	200	6	08.06-08.08	N52B30A, N52B30BF	1,1	PLZFR6A-11S	5987		
X3si xDrive 30i 3.0	E83	3.0	200	6	09.08-09.09	N52B30A, N52B30BF	1,1	ILZFR6D11	1208		
X3si xDrive 30i 3.0	E83	3.0	200	6	09.08-09.09	N52B30A, N52B30BF	1,1	PLZFR6A-11S	5987		
X3si xDrive 30i	E83	3.0	200	6	10.09-12.11	N52B30A, N52B30B, N52B30BF	1,1	LZFR6AP11GS	95712		

X3 (SERIES) F25

X3 sDrive 18i 1.6	F25	1.6	125	4	04.14-	N20B16A	0,75	SILZKBR8D8S	97506		
X3 sDrive 20i 1.6	F25	1.6	125	4	04.14-	N20B16A	0,75	SILZKBR8D8S	97506		
X3 xDrive 20i 2.0	F25	2.0	135	4	09.11-	N20B20A	0,75	SILZKBR8D8S	97506		
X3 sDrive 20i 2.0	F25	2.0	135	4	02.14-	N20B20A	0,75	SILZKBR8D8S	97506		
X3 xDrive 28i 2.0	F25	2.0	180	4	12.10-	N20B20A	0,75	SILZKBR8D8S	97506		
X3 xDrive 28i 3.0	F25	3.0	190	6	01.11-	N52NB30A, N52NB30AF, N52NB30BF	1,1	LZFR6AP11GS	95712		

X3 (SERIES) G01

X3 sDrive 20i 1.6	G01	1.6	125	4	12.17-	B48B16A	0,8	SILZKGR8B8S	94201		
X3 sDrive 20i 2.0	G01	2.0	135	4	12.17-07.19	B48B20A	0,8	SILZKGR8B8S	94201		
X3 xDrive 20i 2.0	G01	2.0	135	4	12.17-07.19	B48B20A	0,8	SILZKGR8B8S	94201		
X3 xDrive 30i 2.0	G01	2.0	183	4	08.17-07.19	B48B20B	0,8	SILZKGR8B8S	94201		
X3 xDrive 30i 2.0	G01	2.0	185	4	08.17-07.19	B48B20B	0,8	SILZKGR8B8S	94201		
X3 xDrive M40i 3.0	G01	3.0	260	6	09.18-08.19	B58B30A	0,8	SILZKGR8B8S	94201		
X3 xDrive M40i 3.0	G01	3.0	265	6	08.17-08.19	B58B30A	0,8	SILZKGR8B8S	94201		

X4 (SERIES) F26

X4 xDrive 20i 2.0	F26	2.0	135	4	04.14-	N20B20A	0,75	SILZKBR8D8S	97506		
X4 xDrive 28i 2.0	F26	2.0	180	4	04.14-	N20B20A	0,75	SILZKBR8D8S	97506		

X4 (SERIES) G02

X4 xDrive 20i 2.0	G02	2.0	135	4	04.18-	B48B20A	0,8	SILZKGR8B8S	94201		
X4 xDrive 30i 2.0	G02	2.0	183	4	04.18-07.19	B48B20B	0,8	SILZKGR8B8S	94201		
X4 xDrive 30i 2.0	G02	2.0	185	4	04.18-	B48B20B	0,8	SILZKGR8B8S	94201		
X4 xDrive M40i 3.0	G02	3.0	260	6	04.18-	B58B30A	0,8	SILZKGR8B8S	94201		
X4 xDrive M40i 3.0	G02	3.0	265	6	04.18-	B58B30A	0,8	SILZKGR8B8S	94201		

X5 (SERIES) E53

X5i 4x4 3.0	E53	3.0	170	6	08.99-09.06	M54B30	1,5	BKR6EQUP	3199	30	LPG 1
X5i 4x4 4.4	E53	4.4	210	8	10.98-09.03	M62B44	1,5	BKR6EQUP	3199	30	LPG 1
X5i 4x4 4.4	E53	4.4	235	8	01.03-09.06	N62B44	1,5	BKR6EQUP	3199	30	LPG 1
X5is 4x4 4.6	E53	4.6	255	8	01.01-09.03	M62B46	1,5	BKR6EQUP	3199	30	LPG 1
X5is 4x4 4.8	E53	4.8	265	8	11.03-09.06	N62B48	1,1	IZFR6H11	4294		

X5 (SERIES) E70

X5 xDrive 30i 3.0	E70	3.0	172	6	02.07-11.09	N52B30A	1,1	ILZFR6D11	1208		
X5 xDrive 30i 3.0	E70	3.0	172	6	02.07-11.09	N52B30A	1,1	PLZFR6A-11S	5987		
X5 xDrive 30i 3.0	E70	3.0	172	6	12.09-12.10	N52B30A	1,1	LZFR6AP11GS	95712		
X5si 3.0	E70	3.0	200	6	10.06-09.08	N52B30A, N52B30AF, N52B30BF	1,1	PLZFR6A-11S	5987		





l kW C
Y
I



Stock-N°

VLINE

LPG/CNG

BMW

X5 (SERIES) E70

X5 xDrive 30i 3.0	E70	3.0	200	6	10.08-11.09	N52B30A	1,1	ILZFR6D11	1208		
X5 xDrive 30i 3.0	E70	3.0	200	6	10.08-11.09	N52B30A	1,1	PLZFR6A-11S	5987		
X5 xDrive 48i 4.8	E70	4.8	261	8	10.08-03.10	N62B48B	1,1	IZFR6H11	4294		

X6 (SERIES) E71

X6 M 4.4	E71	4.4	408	8	06.09-07.14	S63B44A	0,75	SILZKBR8D8S	97506		
----------	-----	-----	-----	---	-------------	---------	------	-------------	-------	--	--

Z3 (SERIES) E36

Z3 1.8	E36	1.8	85	4	02.96-09.98	M43B18	0,9	BKR6EK	2288	20	LPG 1
Z3 1.8	E36	1.8	85	4	01.98-02.99	M43B18	1,5	BKR6EQUP	3199	30	LPG 1
Z3 1.9	E36	1.9	87	4	03.99-06.02	M43B19	1,5	BKR6EQUP	3199	30	LPG 1
Z3 1.9	E36	1.9	103	4	11.95-03.99	M44B19	0,9	BKR6EK	2288	20	LPG 1
Z3 2.0	E36	2.0	110	6	09.98-12.00	M52B20	1,5	BKR6EQUP	3199	30	LPG 1
Z3 Cabrio 2.2	E36	2.2	120	6	08.00-01.03	M54B226S1	1,5	BKR6EQUP	3199	30	LPG 1
Z3 2.2	E36	2.2	125	6	12.99-06.02	M54B22	1,5	BKR6EQUP	3199	30	LPG 1
Z3 2.8	E36	2.8	142	6	06.96-09.98	M52B28	0,9	BKR6EK	2288	20	LPG 1
Z3 2.8	E36	2.8	142	6	01.98-05.00	M52B28	1,5	BKR6EQUP	3199	30	LPG 1
Z3 Coupe 2.8	E36	2.8	142	6	01.98-12.00	M52B28	1,5	BKR6EQUP	3199	30	LPG 1
Z3 Coupe 2.8	E36	2.8	142	6	01.98-05.00	M52B286S1, M52B286S2	0,9	BKR6EK	2288	20	LPG 1
Z3 Cabrio 2.8	E36	2.8	143	6	01.96-07.00	M52B286S1, M52B286S2	0,9	BKR6EK	2288	20	LPG 1
Z3 3.0	E36	3.0	170	6	09.99-06.02	M54B30	1,5	BKR6EQUP	3199	30	LPG 1
Z3 Coupe 3.0	E36	3.0	170	6	09.99-06.02	M54B30	1,5	BKR6EQUP	3199	30	LPG 1
Z3 M 3.2	E36	3.2	236	6	04.96-06.00	S50B32	0,7	PKR7A	3641		
Z3 M Coupe 3.2	E36	3.2	236	6	09.97-07.00	S50B32	0,7	PKR7A	3641		
Z3 M 3.2	E36	3.2	239	6	03.00-05.02	S54B32	0,9	DCPR8EKP	7415		
Z3 M Coupe 3.2	E36	3.2	239	6	03.00-05.02	S54B32	0,9	DCPR8EKP	7415		

Z4 (SERIES) E85

Z4 2.0	E85	2.0	110	4	09.04-	N46B20	1,1	IZFR6H11	4294		
Z4 2.2	E85	2.2	125	6	09.03-	M54B22	1,5	BKR6EQUP	3199	30	LPG 1
Z4 2.5	E85	2.5	141	6	04.03-	M54B25	1,5	BKR6EQUP	3199	30	LPG 1
Z4 Cabrio 2.5 Si	E85	2.5	155	6	09.05-02.09	N52B25A	1,1	ILZFR6D11	1208		
Z4 Cabrio 2.5 Si	E85	2.5	155	6	09.05-02.09	N52B25A	1,1	PLZFR6A-11S	5987		
Z4 Cabrio 2.5 Si	E85	2.5	160	6	01.06-08.08	N52B25A	1,1	PLZFR6A-11S	5987		
Z4 3.0	E85	3.0	170	6	04.03-	M54B30	1,5	BKR6EQUP	3199	30	LPG 1
Z4si 3.0	E85	3.0	195	6	10.05-	N52B30	1,1	ILZFR6D11	1208		
Z4si Cabrio 3.0	E85	3.0	195	6	01.06-08.08	N52B30A, N52B30BF	1,1	PLZFR6A-11S	5987		
Z4 M 3.2	E85	3.2	252	6	03.06-	S54B32	0,9	DCPR8EKP	7415		

Z4 (SERIES) E86

Z4si Coupe 3.0	E86	3.0	195	6	10.05-	N52B30	1,1	ILZFR6D11	1208		
Z4si Coupe 3.0	E86	3.0	195	6	04.06-08.08	N52B30A	1,1	PLZFR6A-11S	5987		
Z4 M Coupe 3.2	E86	3.2	252	6	10.05-	S54B32	0,9	DCPR8EKP	7415		

Z4 (SERIES) E89

Z4 sDrive 18i Cabrio 2.0	E89	2.0	115	4	03.13-	N20B20A	0,75	SILZKBR8D8S	97506		
Z4 sDrive 20i Cabrio 2.0	E89	2.0	135	4	09.11-	N20B20A	0,75	SILZKBR8D8S	97506		
Z4 sDrive 28i Cabrio 2.0	E89	2.0	180	4	09.11-	N20B20A	0,75	SILZKBR8D8S	97506		
Z4 sDrive 23i Cabrio 2.5	E89	2.5	150	6	01.10-	N52B25A, N52B25BF	1,1	LZFR6AP11GS	95712		





l kW C
Y
I



Stock-N°

VLINE

LPG/CNG

BMW

Z4 (SERIES) E89

Z4 sDrive 30i Cabrio 3.0	E89	3.0	190	6	02.09-12.09	N52B30A, N52B30B, N52B30BF	1,1	PLZFR6A-11S	5987		
Z4 sDrive 30i Cabrio 3.0	E89	3.0	190	6	01.10-	N52B30A, N52B30B, N52B30BF	1,1	LZFR6AP11GS	95712		
Z4 sDrive 30i Cabrio 3.0	E89	3.0	195	6	05.09-11.09	N52B30A	1,1	PLZFR6A-11S	5987		
Z4 sDrive 30i Cabrio 3.0	E89	3.0	195	6	12.09-08.11	N52B30A	1,1	LZFR6AP11GS	95712		

Z8 (SERIES) E52

Z8 5.0	E52	5.0	294	8	06.00-07.03	S62B50	1,5	BKR6EQUP	3199	30	LPG 1
--------	-----	-----	-----	---	-------------	--------	-----	----------	------	----	-------

BUICK

CENTURY

Century		2.2		4	.93- .94		1,0	TR4	3754		LPG 5
Century		2.2		4	.95- .96		1,5	TR55-1	2683		
Century		3.1		6	.94- .99	M OHV V6	1,3	TR55IX	7164		LPG 5
Century		3.1		6	.00-	J OHV V6	1,3	TR55IX	7164		LPG 5

LACROSSE

Lacrosse		3.6		6	.05-	V6 7 FI 217	1,0	PLTR6A-10G	3587		
Lacrosse		3.6		6	.05-	V6 2 FI	1,5	TR55	3951		LPG 5

LESABRE

LeSabre		3.0		6	.86-	L V6	1,0	TR5	2238		LPG 5
LeSabre		3.8		6	.92- .95	L V6	1,5	ITR4A15	5599		LPG 5
LeSabre		3.8		6	.96- .01	K V6	1,5	ITR4A15	5599		LPG 5
LeSabre		3.8		6	.02-	K V6	1,5	ITR4A15	5599		LPG 5

PARK AVENUE

Park Avenue		3.8		6	.91-	K V6	1,5	ITR4A15	5599		LPG 5
Park Avenue		3.8		6	.92- .97	1 V6 Super Charged	1,5	ITR4A15	5599		LPG 5
Park Avenue		3.8		6	.02-	V6 1 FI Supercharged, V6 K FI	1,5	TR55	3951		LPG 5

REGAL

Regal		3.8		6	.96-	K V6 MFI, SC V6 MFI 1	1,5	ITR4A15	5599		LPG 5
-------	--	-----	--	---	------	-----------------------	-----	---------	------	--	-------

RIVERA

Rivera		3.8		6	.96- .97	K V6 MFI	1,5	ITR4A15	5599		LPG 5
Rivera		3.8		6	.96-	SC V6 MFI 1	1,5	ITR4A15	5599		LPG 5

CADILLAC

ALLANTE

Allante		4.6		8	.91- .94	8, 9 MFI	1,5	TR55	3951		LPG 5
---------	--	-----	--	---	----------	----------	-----	------	------	--	-------

BLS

BLS 2.0 T		2.0	129	4	04.06-	B207L	1,0	PFR6T-10G	5542		
BLS 2.0 T Flexpower		2.0	147	4	12.07-	Z20LER	1,0	PFR6T-10G	5542		
BLS 2.0 T		2.0	154	4	04.06-	B207R	1,0	PFR6T-10G	5542		

BROUGHAM

Brougham		5.0		8	.91- .92	E TBI	1,1	UR4	6630		UR5IX
Brougham		5.7		8	.91- .92	7 TBI	1,3	UR5	2771		UR6IX
Brougham		5.7		8	.93-	7 TBI	1,1	UR4	6630		UR5IX

CATERA

Catera		3.0		6	.97- .01	R DOHC MFI	0,8	BKR5EK	7956	23	LPG 1
--------	--	-----	--	---	----------	------------	-----	--------	------	----	-------





l kW C
Y
I



Stock-N°

VLINE

LPG/CNG

CADILLAC

CONCOURS

Concours	4.6		8	.94- .94	Y SFI	1,5	TR55	3951		LPG 5
Concours	4.6		8	.95- .95	Y MFI	1,5	TR55	3951		LPG 5
Concours	4.6		8	.96- .98	9 MFI	1,5	TR55	3951		LPG 5

CTS-V

CTS-V	5.7	298	8	.05-		1,5	TR55	3951		LPG 5
-------	-----	-----	---	------	--	-----	------	------	--	-------

DE VILLE

De Ville	4.6		8	.96- .98	Y MFI	1,5	TR55	3951		LPG 5
De Ville	4.6		8	.99-	Y MFI	1,5	TR55	3951		LPG 5
De Ville	4.6		8	.01-	9 MFI	1,5	TR55	3951		LPG 5
De Ville	4.9		8	.91- .91	B MFI	1,5	TR55	3951		LPG 5
De Ville	4.9		8	.92- .95	B MFI	1,5	TR55	3951		LPG 5

ELDORADO

Eldorado	4.6		8	.93- .93	9, Y MFI	1,5	TR55	3951		LPG 5
Eldorado	4.6		8	.94- .98	9 MFI/SFI, Y MFI, SFI	1,5	TR55	3951		LPG 5
Eldorado	4.6		8	.99-	V8 MFI 9, V8 MFI Y	1,5	TR55	3951		LPG 5
Eldorado	4.9		8	.92- .93	B MFI	1,5	TR55	3951		LPG 5

SEVILLE

Seville	4.6		8	.99-	V8 MFI 9, V8 MFI Y	1,5	TR55	3951		LPG 5
---------	-----	--	---	------	--------------------	-----	------	------	--	-------

SRX

SRX Sport Luxury	4.6	239	8	10.04-	A V8 FI	1,5	PTR5D-10	6344	31	LPG 5
------------------	-----	-----	---	--------	---------	-----	----------	------	----	-------

XLR

XLR	4.6	239	8	.05-	A V8 FI	1,5	TR55	3951		LPG 5
-----	-----	-----	---	------	---------	-----	------	------	--	-------

CATERHAM

SUPER

Super Seven HPC	2.0	110	4	07.91-	Opel 16V	0,8	BCPR7ES	3330		BCPR7EIX
-----------------	-----	-----	---	--------	----------	-----	---------	------	--	----------

CHEVROLET

ALERO

Alero	3.4		6	03.99-	LA1	1,5	TR55	3951		LPG 5
-------	-----	--	---	--------	-----	-----	------	------	--	-------

AVEO

Aveo 1.2 ECOTEC	T300	1.2	51	4	06.11-12.15	LWD	0,9	ZFR6V-G	8894		
Aveo 1.2		1.2	53	4	02.05- .08	F12S3	1,1	BPR5EY-11	3028		LPG 2
Aveo 1.2		1.2	55	4	04.08-12.11	B12D1	0,9	DCPR8E	4339		LPG 8
Aveo 1.2	T250	1.2	55	4	01.09-12.12	LMU	0,9	DCPR8E	4339		LPG 8
Aveo 1.2 BiFuel	T255	1.2	60	4	06.08-11.12	LMU	0,9	DCPR8E	4339		LPG 8
Aveo 1.2		1.2	62	4	04.08-	B12D1	0,9	DCPR8E	4339		LPG 8
Aveo 1.2 (For OE-No. 55565219)	T300	1.2	63	4	03.11-	LDC	0,9	ZFR6V-G	8894		
Aveo 1.2 (For OE-No. 25197812)	T300	1.2	63	4	03.11-	LDC	0,7	IZFR5R7G	94123		
Aveo 1.4		1.4	69	4	02.05- .08	F14D3	1,1	BKR6E-11	2756	14	LPG 1
Aveo 1.4 16V SX		1.4	69	4	12.05- .08	F14D3 DOHC	1,1	BKR6E-11	2756	14	LPG 1
Aveo 1.4	T250	1.4	74	4	01.08-	F14D4	0,9	ZFR6U-9	90318		
Aveo 1.4	T255	1.4	74	4	04.08-	F14D4, G14D	0,9	ZFR6U-9	90318		
Aveo 1.4		1.4	74	4	.08-	F14D4	1,1	ZFR6F-11	4291		LPG 6
Aveo 1.4 ECOTEC	T300	1.4	74	4	06.11-	LDD	0,9	ZFR6V-G	8894		
Aveo 1.6 DVVT	T300	1.6	85	4	06.11-	LDE	0,9	ZFR6V-G	8894		





e kW C
Y
I



Stock-Nº

VLINE

LPG/CNG

CHEVROLET

BLAZER

Blazer	4.3		6	.95- .05	V6 W EFI	1,3	UR5	2771		UR6IX
Blazer	4.3		6	.96- .02	V6 W EFI	1,0	TR5	2238		LPG 5
Blazer	4.3		6	.03- .03	V6 X EFI	1,0	TR5	2238		LPG 5
Blazer	5.7		8	.87- .93	V8 K EFI, V8 K TBI	1,3	UR5	2771		UR6IX
Blazer	5.7		8	.94- .94	V8 K EFI	1,3	UR6	7773		
Blazer	5.7		8	.94-	V8 K TBI	1,3	UR6	7773		

CAMARO

Camaro	2.8		6	.82-	1 2 bbl CID173	1,3	UR5	2771		UR6IX
Camaro	3.1		6	.90- .92	T V6 EFI	1,3	UR5	2771		UR6IX
Camaro	3.4		6	.93- .95	S V6 EFI	1,3	UR5	2771		UR6IX
Camaro 3.6 VVTi	EE37	3.6	224	6	09.09-12.10	LLT	1,1	ILTR6E11	90117	
Camaro 3.6 VVTi	EE37	3.6	227	6	09.09-12.12	LLT	1,1	ILTR6E11	90117	
Camaro 3.6 -/VVTi	EE37	3.6	241	6	12.12-12.15	LFX	1,1	ILTR6E11	90117	
Camaro	3.8		6	.96-	V6 MFI K	1,5	TR55	3951		LPG 5
Camaro	3.8		6	.01-		1,5	ITR4A15	5599		LPG 5
Camaro	5.0		8	.82-	7 EFI CID305	1,1	UR4	6630		UR5IX
Camaro	5.0		8	.83-	S EFI CID305	1,1	UR4	6630		UR5IX
Camaro	5.0		8	.85- .92	F V8 EFI	1,1	UR4	6630		UR5IX
Camaro	5.0		8	.88- .92	E V8 EFI	1,1	UR4	6630		UR5IX
Camaro	5.7		8	.87- .92	V8 EFI Alu Heads	0,9	FR4	5155		
Camaro	5.7		8	.87- .92	V8 EFI Cast Iron Heads	1,1	UR4	6630		UR5IX
Camaro	5.7		8	.93- .97	P V8 EFI	1,5	TR55	3951		LPG 5
Camaro	5.7		8	.98- .02	G V8 EFI	1,5	TR55	3951		LPG 5

CAPTIVA

Captiva 2.4	2.4	100	4	09.06-	Z24SED	0,8	BKR5EK	7956	23	LPG 1
Captiva 3.0 VVT	C140	3.0	186	6	01.12-	LFW	1,1	ILTR6E11	90117	
Captiva 3.0 VVT	C140	3.0	190	6	01.10-	A30XH	1,1	ILTR6E11	90117	
Captiva 3.2		3.2	169	6	09.06-	Z32SED	1,3	PTR5A-13	2467	25 LPG 4

CORVETTE

Corvette	5.7	294	8	.97- .00	G V8 EFI	1,5	TR55	3951		LPG 5
Corvette	5.7		8	.88- .91	8 V8 EFI Cast Iron Heads	1,1	UR4	6630		UR5IX
Corvette	5.7		8	.90- .92	J V8 EFI ZR1	1,5	TR55	3951		LPG 5
Corvette	5.7		8	.92- .96	P V8 EFI	1,5	TR55	3951		LPG 5
Corvette	5.7		8	.93- .95	J V8 EFI	1,5	TR55	3951		LPG 5
Corvette	5.7		8	.96- .96	5 V8 EFI	1,5	TR55	3951		LPG 5
Corvette	5.7		8	.01- .03	G V8 EFI	1,5	TR55	3951		LPG 5
Corvette	5.7		8	.01- .01	S V8 EFI	1,5	TR55	3951		LPG 5
Corvette	5.7		8	.03- .04	V8	1,5	PZTR5A-15	7862		
Corvette	6.0		8	.05-	V8	1,5	PZTR5A-15	7862		

CRUZE

Cruze 1.4 ECOTEC	J305	1.4	103	4	06.12-	A14NET	0,7	IFR7X7G	91039	
Cruze 1.6	J300, J305	1.6	83	4	05.09-	F16D4	1,1	ZFR6F-11	4291	LPG 6
Cruze 1.6 DVVT	J300	1.6	86	4	12.12-	F16D4	0,9	ZFR6U-9	90318	
Cruze 1.6 DVVT	J305	1.6	86	4	12.12-	F16D4	0,9	ZFR6U-9	90318	
Cruze 1.6 DVVT	J308	1.6	86	4	12.12-12.15	F16D4	0,9	ZFR6U-9	90318	





l kW C
Y
I



Stock-Nº

VLINE

LPG/CNG

CHEVROLET

CRUZE

Cruze 1.6	J300, J305	1.6	91	4	05.09-	F16D4	1,1	ZFR6F-11	4291		LPG 6
Cruze 1.6 DVVT	J308	1.6	91	4	08.12-12.13	F16D4	0,9	ZFR6U-9	90318		
Cruze 1.8	J300, J305	1.8	104	4	05.09-	F18D4	1,1	ZFR6F-11	4291		LPG 6
Cruze 1.8 DVVT BiFuel	J305	1.8	104	4	06.11-12.15	F18D4	0,9	ZFR6U-9	90318		
Cruze 1.8 DVVT	J308	1.8	104	4	08.12-	F18D4	0,9	ZFR6U-9	90318		

EPICA

Epica		2.0	106	6	06.06-	XK	0,8	BKUR6ETB	6992		
Epica		2.5	115	6	06.06-		1,1	IFR6E11	6741		

EVANDA

Evanda		2.0	96	4	02.05-	T20SED DOHC 16v	0,8	BKR5EK	7956	23	LPG 1
--------	--	-----	----	---	--------	-----------------	-----	--------	------	----	-------

KALOS

Kalos 1.2		1.2	53	4	02.05-	B12S1	1,1	BPR5EY-11	3028		LPG 2
Kalos 1.4		1.4	61	4	02.05-	F14S3 SOHC	0,8	BPR6ES	7822	2	LPG 2
Kalos 1.4 16V SX		1.4	69	4	02.05-	F14D3 DOHC	1,1	BKR6E-11	2756	14	LPG 1

LACETTI

Lacetti		1.4	70	4	02.05-	F14D3	1,1	BKR6E-11	2756	14	LPG 1
Lacetti		1.6	80	4	02.05-	F16D3	1,1	BKR6E-11	2756	14	LPG 1
Lacetti 1.8		1.8	89	4	08.05-	F18D3	0,8	BKUR6ETB	6992		

LUMINA

Lumina		3.8		6	.98-	V6 MFI K	1,5	ITR4A15	5599		LPG 5
--------	--	-----	--	---	------	----------	-----	---------	------	--	-------

MALIBU

Malibu 1.8		1.8	108	4	01.16-12.17	U18YHY	0,8	SILNAR7B7	93227		
Malibu		2.4		4	.97- .99	T MFI DOHC	1,5	TR55	3951		LPG 5
Malibu 3.0	V300	3.0	196	6	09.14-12.15	LFW	1,1	ILTR6E11	90117		
Malibu		3.1		6	.97- .99	M V6 MFI	1,5	TR55	3951		LPG 5
Malibu		3.1		6	.00-	J V6 SFI	1,5	TR55	3951		LPG 5

MATIZ

Matiz		0.8	38	3	02.05-	F8CV	1,1	BCPR5EY-11	4120		LPG 3
Matiz		1.0	47	4	02.05-	B10S	1,1	BCPR5EY-11	4120		LPG 3

METRO

Metro		1.0		3	.98-	L3 TBI 6	1,1	BPR6ES-11	4824	13	LPG 2
Metro		1.3		4	.98-	L4 TBI 9	1,1	BKR6E-11	2756	14	LPG 1

NUBIRA

Nubira 1.6		1.6	80	4	02.05-	A16DMS DOHC	1,1	BKR6E-11	2756	14	LPG 1
Nubira 1.8 CDX		1.8	89	4	02.05-	T18SED	0,8	BKR5EK	7956	23	LPG 1
Nubira 1.8		1.8	89	4	08.05-	F18D3	0,8	BKUR6ETB	6992		

ORLANDO

Orlando 1.8 DVVT BiFuel	J309	1.8	104	4	06.11-12.15	F18D4	0,9	ZFR6U-9	90318		
-------------------------	------	-----	-----	---	-------------	-------	-----	---------	-------	--	--

PRIZUM

Prizum		1.8		4	.98- .99	L4 MPI 8 DOHC	1,1	BKR5EKB-11	3967		
Prizum		1.8		4	.00-	L4 MPI 8 DOHC	1,1	IFR5T11	4996		

REZZO

Rezzo / Tacuma U100		1.6	77	4	02.05-	A16DMS	1,1	BKR5E-11	6953	33	LPG 1
Rezzo / Tacuma		1.8	72	4	.00-	F18S2 SOHC	0,9	BPR5ES	7422	6	LPG 2
Rezzo / Tacuma U100		2.0	89	4	02.05-	T20SED	0,8	BKR5EK	7956	23	LPG 1



e kW C
Y I

Stock-N°

VLINE

LPG/CNG

CHEVROLET**SPARK**

Spark 1.0 / 1.0 LPG	M300	1.0	50	4	03.10-	B10D1	0,9	DCPR8E	4339		LPG 8
Spark 1.2 / 1.2 LPG	M300	1.2	60	4	03.10-	B12D1	0,9	DCPR8E	4339		LPG 8

TAHOE

Tahoe		4.8		8	.00- .00	V FI V8	1,5	TR55	3951		LPG 5
Tahoe		4.8		8	.01-	V FI V8	1,5	TR55	3951		LPG 5
Tahoe		5.3	201	8	.00-	T FI V8	1,5	TR55	3951		LPG 5
Tahoe		5.3		8	.02- .03	Z FLEX V8	1,5	TR55	3951		LPG 5
Tahoe		5.3		8	.04-	Z FI V8	1,5	TR55	3951		LPG 5
Tahoe		5.3		8	.05-	Z FLEX V8 323	1,5	TR55	3951		LPG 5
Tahoe		5.7	147	8	04.96- .00	R V8	1,5	TR55	3951		LPG 5

TRAIL BLAZER

Trail Blazer 4.2 LTZ		4.2	201	6	.02- .03	S EFI	1,3	PTR5A-13	2467	25	LPG 4
Trail Blazer 5.3		5.3		8	.03-	V8 P EFI	1,5	TR55	3951		LPG 5

TRAX

Trax 1.4 BiFuel	76	1.4	103	4	04.13-12.15	A14NET	0,7	IFR7X7G	91039		
Trax 1.4 ECOTEC	76	1.4	103	4	04.13-	A14NET	0,7	IFR7X7G	91039		

CHRYSLER**300**

300		2.7		6	.05-	V6 R FI Dir. Ign.	1,3	LZTR5A-13	4612		
-----	--	-----	--	---	------	-------------------	-----	-----------	------	--	--

300 C

300 C		2.7	142	6	01.05-	V6	1,3	LZTR5A-13	4612		
300 C		3.5	183	6	07.04-	V6 G FI	1,3	ZFR5LP-13G	7781		
300 C (Twin Spark)		5.7	250	8	09.04-12.08	V8 HEMI	1,1	LZTR4A-11	5444		
300 C SRT8 (Twin Spark)		6.1	316	8	.06-	W V	1,3	PLZTR5A-13	4998		

300 M

300 M		2.7	150	6	08.00-09.04	V6 EER	1,3	LZTR5A-13	4612		
300 M		3.5	189	6	09.99-	V6 G FI	1,3	ZFR5LP-13G	7781		
300 M		3.5		6	.03-	V6 K FI Dir. Ign.	1,3	ZFR5LP-13G	7781		

300C

CHRYSLER 300C 5.7 HEMI/HEMI SRT8	LE	5.7	250	8	01.09-12.10	EZB, EZD, EZH	1,1	LZFR5CI-11	92145		
CHRYSLER 300C 5.7 HEMI	LE	5.7	265	8	05.09-12.10	EZH	1,1	LZFR5CI-11	92145		
CHRYSLER 300C 5.7 HEMI	LE	5.7	268	8	01.09-12.10	EZH	1,1	LZFR5CI-11	92145		

ASPEN

CHRYSLER Aspen 5.7 (HG)		5.7	254	8	01.09-12.09	EZB	1,1	LZFR5CI-11	92145		
CHRYSLER Aspen 5.7 HEMI	HG	5.7	280	8	04.08-12.08	EZD	1,1	LZFR5CI-11	92145		
CHRYSLER Aspen 5.7 (HG)		5.7	293	8	01.09-	EZE	1,1	LZFR5CI-11	92145		

CIRRUS

Cirrus		2.4		4	.99-	X DOHC	1,3	FR45	3686		
Cirrus		2.5		6	.95-	V6 MPI H DOHC	1,1	PFR5G-11	2647		

CONCORDE

Concorde		2.7		6	.98-	V6 MPI R DOHC	1,3	PTR5A-13	2467	25	LPG 4
Concorde		3.3		6	.93- .96	V6 MPI T	1,2	GR45	4268		GR5IX
Concorde		3.3		6	.94- .94	V6 FF U	1,2	GR45	4268		GR5IX
Concorde		3.5		6	.93- .97	V6 MPI F	0,9	FR5-1	7252		





l kW C
Y
I



Stock-N°

VLINE

LPG/CNG

CHRYSLER

DODGE VIPER

Dodge Viper	8.0		10	.96-	E MPI V10	0,9	FR5-1	7252		
-------------	-----	--	----	------	-----------	-----	-------	------	--	--

IMPERIAL

Imperial	3.3		6	.90- .91	V6 MPI 3	1,2	GR45	4268		GR5IX
Imperial	3.8		6	.91- .93	V6 MPI L	1,2	GR45	4268		GR5IX

NEON

Neon	1.8		4	03.98-10.99		0,9	BKR6E	6962	28	LPG 1
Neon LE	2.0	98	4	01.95-	ECB 16V	0,8	BCPR6ES	2330	12	LPG 3

PT

PT Cruiser 2.0	2.0	104	4	06.00-		1,1	LZTR4A-11	5444		
PT Cruiser 2.4	2.4	105	4	08.05-	EDZ	1,1	LZTR4A-11	5444		
PT Cruiser 2.4	2.4	110	4	06.00-	EDZ	1,1	LZTR4A-11	5444		
PT Cruiser GT 2.4	2.4	164	4	08.03-	EDV	1,1	LZTR4A-11	5444		

SEBRING

Sebring	2.0	104	4	06.01-	EC4	1,1	LZTR4A-11	5444		
Sebring	2.0		4	.95- .99	L4 MPI Y DOHC	1,1	BKR6EIX-11	3764		LPG 1
Sebring	2.4		4	.96- .98	L4 MPI X DOHC	1,1	FR45	3686		
Sebring	2.4		4	.01-	4G64 SOHC	1,1	BKR5E-11	6953	33	LPG 1
Sebring	2.5		6	.95- .99	V6 MPI N DOHC	1,1	PFR5G-11	2647		

STRATUS

Stratus	2.0	96	4	.00-		0,9	BKR6E	6962	28	LPG 1
Stratus	2.0	98	4	.95- .00	ECB 16V	0,8	BCPR6ES	2330	12	LPG 3
Stratus	2.5	120	6	04.95-	EEB V6 MPI	1,1	PFR6B-11	4014		PFR7B

VOYAGER 1

Voyager 1	3.0	100	6	.88- .91	EFA	1,1	BPR5ES-11	4424		LPG 2
-----------	-----	-----	---	----------	-----	-----	-----------	------	--	-------

VOYAGER 2

Voyager 2	2.0	98	4	.97-01.01	ECB COO	0,9	BKR6E	6962	28	LPG 1
Voyager 2	2.4	110	4	.96-01.01	EDZ BOO	1,1	ZFR5A-11	5084		LPG 6
Voyager 2	2.5	72	4	.91- .95	EDM	0,8	BPR6ES	7822	2	LPG 2
Voyager 2	3.3	116	6	.96-01.01	EGA V6 MPI R	0,9	GR4IX	97382		GR5IX
Voyager 2	3.3	120	6	.91- .95	EGA V6 MPI R	1,3	GR4	2635		GR5IX
Voyager 2	3.3	122	6	.96-01.01	EGA V6 MPI	0,9	GR4	2635		GR5IX
Voyager 2	3.8	122	6	.96-01.01	EGH V6 MPI	0,9	GR4	2635		GR5IX

VOYAGER 3

Voyager 3	2.4	108	4	03.01-	EDZ	1,3	LZTR5A-13	4612		
Voyager 3	2.4	112	4	.00-		1,3	FR45	3686		

VOYAGER 4

Voyager 4 3.3 (RG)	3.3	128	6	03.01-	EGA	1,3	PLZTR5A-13	4998		
--------------------	-----	-----	---	--------	-----	-----	------------	------	--	--

CITROËN

AX

AX 1.0i	1.0	30	4	10.86-	TU9	0,7	BCP6ES	4930	17	LPG 3
AX 1.0i	1.0	37	4	07.92-	TU9.M Cat.	0,8	BKR5EK	7956	23	LPG 1
AX 1.0i	1.0	37	4	03.95-	TU9M CDZ	0,8	BKR5EK	7956	23	LPG 1
AX 1.0i	1.0		4	09.86-06.92	TU9 C1A	0,8	BCP5ES	7496	16	LPG 3
AX 1.0i	1.0		4	07.92-02.95	TU9M CDZ	0,8	BCPR5ES	6130	32	LPG 3
AX 1.1	1.1	44	4	07.92-06.95	TU1M HDZ Cat.	0,8	BCPR5ES	6130	32	LPG 3





e kW C
y
i



Stock-N°

VLINE

LPG/CNG

CITROËN

AX

AX 1.1i	1.1		4	09.86-06.92	TU1 H1A	0,8	BCP5ES	7496	16	LPG 3
AX 1.1i	1.1		4	07.92-06.95	TU1M HDZ	0,8	BCPR5ES	6130	32	LPG 3
AX 1.1i	1.1		4	07.95-	TU1M HDZ	0,8	BKR5EK	7956	23	LPG 1
AX 1.3i Sport	1.3	69	4	02.87-12.92	TU24 M4A	0,8	BKUR7ET	7873		
AX 1.4i	1.4	55	4	07.92-	TU3MC Cat.	0,9	BKR6EK	2288	20	LPG 1
AX 1.4i GT	1.4	55	4	07.92-	TU3FM Cat.	0,9	BKR6EK	2288	20	LPG 1
AX 1.4i	1.4	55	4	07.94-	TU3FM	0,9	BKR6EK	2288	20	LPG 1
AX 1.4	1.4		4	09.86-12.92	TU3 K1A, TU3A K1G	0,8	BCP5ES	7496	16	LPG 3
AX 1.4 GT	1.4		4	10.87-12.92	TU3S K2A	0,7	BCP6ES	4930	17	LPG 3
AX 1.4 Gti	1.4		4	09.91-12.92	TU3J2 K6B	0,9	BKR6EK	2288	20	LPG 1
AX 1.4i Gti	1.4		4	09.91-12.92	TU3FJ2Z	0,9	BKR6EK	2288	20	LPG 1
AX 1.4	1.4		4	07.92-	TU3M Cat.	0,8	BCPR5ES	6130	32	LPG 3
AX 1.4i	1.4		4	07.92-06.95	TU3MC KDX	0,8	BCPR5ES	6130	32	LPG 3
AX 1.4i GT	1.4		4	07.92-06.95	TU3MC KDX	0,8	BCPR5ES	6130	32	LPG 3
AX 1.4 Gti	1.4		4	07.92-	TU3J2 KFZ	0,9	BKR6EK	2288	20	LPG 1
AX 1.4i	1.4		4	07.95-	TU3MC KDX	0,9	BKR6EK	2288	20	LPG 1

BERLINGO

Berlingo	GBHFXB, GCHF XB, GCHTXB, MAHDZE, MAHDZV, MAHFXB, MBHDZV, MBHFXB, MCHDZE, MCHDZF, MCHF WB, MCHF XB	1.1	44	4	07.96-03.08	TU1M +	0,9	BCPR5ES	6130	32	LPG 3
Berlingo	MBHDZE, MCHDZE	1.1	44	4	07.96-10.02	TU1M +	0,9	BCPR5ES	6130	32	LPG 3
Berlingo 1.1i		1.1	44	4	07.96-	TU1M HDZ	0,9	BKR6EK	2288	20	LPG 1
Berlingo	GBHFXB, GCHF XB, GCHTXB, MAHDZE, MAHDZV, MAHFXB, MBHDZV, MBHFXB, MCHDZE, MCHDZF, MCHF WB, MCHF XB	1.1	44	4	07.96-03.08	TU1JP	0,9	BKR6EZ	4619	38	LPG 1
Berlingo 1.1	G HFX, G HTX, M HDZ, M HFX	1.1	44	4	07.96-03.08	TU1JP	0,9	BKR6EZ	4619	38	LPG 1
Berlingo 1.1	G HFX, GHTX, MHDZ, MHFX	1.1	44	4	07.96-03.08	TU1M +	0,9	BKR6EZ	4619	38	LPG 1
Berlingo MultiSpace 1.1	G HTX, M HDZ, M HFX	1.1	44	4	07.96-05.08	TU1JP	0,9	BKR6EZ	4619	38	LPG 1
Berlingo MultiSpace 1.1	GHTX, MHDZ, MHFX	1.1	44	4	07.96-05.08	TU1M +	0,9	BKR6EZ	4619	38	LPG 1
Berlingo MultiSpace 1.4	G KFW	1.4	53	4	11.02-10.05	TU3JP	0,9	BKR6EZ	4619	38	LPG 1
Berlingo 1.4i		1.4	55	4	07.96-12.99	TU3JP-KFX,KFW	0,9	BKR6EK	2288	20	LPG 1
Berlingo 1.4i		1.4	55	4	01.00-	TU3JP KFX	0,9	BKR6EZ	4619	38	LPG 1





l kW C
Y
I



Stock-N°

VLINE

LPG/CNG

CITROËN

BERLINGO

Berlingo 1.4	G KFW, M KFX	1.4	57	4	08.99-05.08	TU3JP	0,9	BKR6EZ	4619	38	LPG 1
Berlingo 1.6 95 Vti		1.6	72	4	07.10-	EP6CDTR	0,8	PLZKBR7B8G	91530		
Berlingo 1.6i 16V		1.6	80	4	02.01-	TU5JP4-NFU	0,9	LF6B	6677	47	LPG 7
Berlingo 1.6 120 Vti		1.6	88	4	11.09-	EP6C	0,8	PLZKBR7B8G	91530		
Berlingo	7BNFSB, 7BNFSC, 7CNFSC	1.6	88	4	11.09-	EP6C	0,8	PLZKBR7B8G	91530		
Berlingo 1.6	7 5FS	1.6	88	4	11.09-	EP6C	0,8	PLZKBR7B8G	91530		
Berlingo 1.6 155 THP		1.6	115	4	04.08-	EP6CDTR	0,8	PLZKBR7B8G	91530		
Berlingo 1.8i		1.8	66	4	07.96-	XU7JB LFX	0,9	BKR6EK	2288	20	LPG 1

BERLINGO MULTISPACE

Berlingo	GJHTXB, MFHDZE, MFHFWBA	1.1	44	4	07.96-05.08	TU1M +	0,9	BCPR5ES	6130	32	LPG 3
Berlingo	MFHDZE	1.1	44	4	07.96-10.02	TU1M +	0,9	BCPR5ES	6130	32	LPG 3
Berlingo	GJHTXB, MFHDZE, MFHFWBA	1.1	44	4	07.96-05.08	TU1JP	0,9	BKR6EZ	4619	38	LPG 1
Berlingo	GJKFWBGL	1.4	53	4	11.02-10.05	TU3JP	0,9	BKR6EZ	4619	38	LPG 1
Berlingo	GJKFWB	1.4	54	4	05.05-05.08	TU3JP	0,9	BKR6EZ	4619	38	LPG 1
Berlingo	GJKFWB, MFK5AF, MFKFXFA	1.4	55	4	07.96-10.08	TU3JP	0,9	BKR6EZ	4619	38	LPG 1
Berlingo	MFKFXFA	1.4	55	4	11.96-10.02	TU3JP	0,9	BKR6EZ	4619	38	LPG 1
Berlingo Multispace 1.4i		1.4	55	4	01.97-12.99	TU3JP KFX, KFW	0,9	BKR6EK	2288	20	LPG 1
Berlingo Multispace 1.4i		1.4	55	4	01.00-	TU3JP KFX, KFW	0,9	BKR6EZ	4619	38	LPG 1
Berlingo Multispace 1.6i		1.6	81	4	02.01-	TU5JP4-NFU	0,9	LF6B	6677	47	LPG 7
Berlingo	7JF01B, 7JF01C	1.6	88	4	11.09-	EP6C	0,8	PLZKBR7B8G	91530		
Berlingo Multispace 1.8i		1.8	66	4	07.97-	XU7JB LFX	0,9	BKR6EK	2288	20	LPG 1

BX 14

BX 14		1.4	47	4	07.88-	TU3.A	0,9	BCP5ES	7496	16	LPG 3
-------	--	-----	----	---	--------	-------	-----	--------	------	----	-------

BX 15

BX 15		1.5	59	4	07.87-06.92	XU5.1C	0,9	BCP5ES	7496	16	LPG 3
-------	--	-----	----	---	-------------	--------	-----	--------	------	----	-------

BX 16

BX 16		1.6	68	4	04.88-06.92	XU5.2C	0,9	BCP6ES	4930	17	LPG 3
BX 16 16V		1.6		4	07.87-06.92	XU9.J4	0,9	BCP6ET	4563		LPG 3
BX 16		1.6		4	07.92-	XU5MZ BDZ Cat.	0,9	BCPR5ES	6130	32	LPG 3
BX 16i Image, Millésime		1.6		4	07.92-	XU5M BDY cat.	0,9	BCPR5ES	6130	32	LPG 3
BX 16 16V		1.6		4	07.92-	XU9.J4 Cat.	0,9	BCPR6ET	2197		LPG 3

BX 19

BX 19		1.9	77	4	07.89-06.92	XU92C, XU92C D2E	0,9	BCP6ES	4930	17	LPG 3
BX 19i Gti, Tri, Tzi / 4x4		1.9		4	07.86-06.92	XU9J2 D6A	0,9	BCP6ES	4930	17	LPG 3
BX 19i Gti 16S		1.9		4	07.87-06.92	XU9J4 D6C	0,9	BCP6ET	4563		LPG 3
BX 19i Gti		1.9		4	07.88-06.92	XU9.J2	0,9	BCP6ES	4930	17	LPG 3
BX 19i		1.9		4	07.92-	XU9.JA DKZ Cat.	0,9	BCPR5ES	6130	32	LPG 3
BX 19i Gti 16S		1.9		4	07.92-	XU9J4 DFW cat.	0,9	BCPR6ET	2197		LPG 3

C1

C1	PMCFAC	1.0	50	3	06.05-12.12	384F	1,1	LF6C-11	5788	48	
C1	PMCFAC, PNCFAF	1.0	50	3	06.05-03.14	1KR-FE	1,1	LF6C-11	5788	48	





e kW C
y
i



Stock-N°

VLINE

LPG/CNG

CITROËN

C1

C1 1.0 VTi	PSCFB2, PSCFBB	1.0	51	3	04.14-	1KR-FE	1,1	LFR6C-11	5788	48	
C1 1.2 VTi	PAHMTB	1.2	60	3	04.14-	EB2D	1,0	LZKR6AI-10G	97999		

C1 I

C1 I 1.0		1.0	50	3	06.05-	1KR-FE	1,1	LFR6C-11	5788	48	
----------	--	-----	----	---	--------	--------	-----	----------	------	----	--

C1 II

C1 II 1.0 Vti (Euro 5 / Euro 6)	PSCFB2, PSCFB3, PSCFBB, PSCFBC	1.0	51	3	04.14-	1KR	1,1	DF6H-11B	5989		
C1 II 1.0 Vti 68		1.0	51	3	.14-		1,0	LZKR6AI-10G	97999		
C1 II 1.0 VTi/VTi 72 (Euro 5 / Euro 6)	PSCFB4, PSCFBD	1.0	53	3	06.18-	1KR	1,1	DF6H-11B	5989		
C1 II 1.2 Vti 82		1.2	60	3	.14-	EB2D	1,0	LZKR6AI-10G	97999		

C15

C15 E		1.0	33	4	09.88-	TU9 C1A	0,9	BCP5ES	7496	16	LPG 3
C15 E		1.1	44	4	09.92-06.95	TU1.M HDZ Cat.	0,9	BCPR5ES	6130	32	LPG 3
C15 E		1.1		4	10.88-	TU1 H1A	0,9	BCP5ES	7496	16	LPG 3
C15 E		1.4		4	10.87-	TU3A K1G	0,9	BCP5ES	7496	16	LPG 3
C15E		1.1		4	07.95-	TU1M HDZ	0,8	BKR5EK	7956	23	LPG 1

C2

C2	JMHFXB	1.1	44	4	07.03-12.09	TU1A, TU1JP	0,9	BKR6EZ	4619	38	LPG 1
C2	JGHFXB	1.1	44	4	11.03-12.09	TU1A, TU1JP	0,9	BKR6EZ	4619	38	LPG 1
C2 1.1	JGHFXB	1.1	44	4	11.03-12.09	TU1A, TU1JP	0,9	BKR6EZ	4619	38	LPG 1
C2		1.1	45	4	08.03-	TU1JP	0,9	BKR6EZ	4619	38	LPG 1
C2	JMKFVB, JMKFVC	1.4	54	4	09.03-12.09	TU3A, TU3JP	0,9	BKR6EZ	4619	38	LPG 1
C2	JMKFVB, JMKFVC	1.4	55	4	07.03-12.09	TU3JP	0,9	BKR6EZ	4619	38	LPG 1
C2 1.4	JMKFVB, JMKFVC	1.4	55	4	07.03-12.09	TU3JP	0,9	BKR6EZ	4619	38	LPG 1
C2		1.4	55	4	08.03-	TU3JP	0,9	BKR6EZ	4619	38	LPG 1
C2	JMKFUB, JMKFUC	1.4	65	4	04.05-12.09	ET3J4	0,9	LZKAR7A	6799	54	
C2	JMNFUB, JMNFUC	1.6	80	4	07.03-10.10	TU5JP4	0,9	LFR6B	6677	47	LPG 7
C2 16V		1.6	81	4	08.03-	TU5JP4	0,9	LFR6B	6677	47	LPG 7
C2 16V		1.6	92	4	01.05-	TU5JP4	0,9	LFR6B	6677	47	LPG 7

C25

C25		2.0	58	4	09.81-03.94	XM7T, XN1T, XN1TA	0,9	BP6ES	7811	4	LPG 2
-----	--	-----	----	---	-------------	-------------------	-----	-------	------	---	-------

C3

C3	FCHF5, FCHF6, FCHF7, FNHFXB, FNHFXC	1.1	44	4	02.02-12.09	TU1A, TU1JP	0,9	BKR6EZ	4619	38	LPG 1
C3		1.1	44	4	04.02-	TU1A-HFX, TU1JP-HFZ, HFY	0,9	BKR6EZ	4619	38	LPG 1
C3 1.1 BiFuel	FNHFXB	1.1	44	4	06.06-12.09	TU1A	0,9	BKR6EZ	4619	38	LPG 1
C3 1.1 BiFuel	FCHF6, FNHFXB	1.1	44	4	06.06-12.09	TU1A	0,9	BKR6EZ	4619	38	LPG 1
C3	SCHFV0	1.1	44	4	01.10-	TU1A	0,9	BKR6EZ	4619	38	LPG 1
C3 1.1 BiFuel	SCHFV0	1.1	44	4	11.10-09.16	TU1A	0,9	BKR6EZ	4619	38	LPG 1
C3 1.2 PureTech 68/VTi	SXHMM6, SXHMP6	1.2	50	3	07.16-	EB2FAD, EB2FB	1,0	LZKR6AI-10G	97999		





l kW C
Y
I



Stock-N°

VLINE

LPG/CNG

CITROËN

C3

C3 1.2 VTi LPG	SXHMx6	1.2	60	3	07.16-	EB2F	1,0	LZKR6AI-10G	97999		
C3 Aircross 1.2 PureTech 82	2RHMRc, 2RHMZB	1.2	60	3	06.17-	EB2F, EB2FA	1,0	LZKR6AI-10G	97999		
C3 1.2 PureTech 82 LPG	SXHMR6	1.2	61	3	05.18-	EB2FA	1,0	LZKR6AI-10G	97999		
C3 1.2 PureTech 82	SXHMR6	1.2	61	3	05.18-	EB2FA	1,0	LZKR6AI-10G	97999		
C3 1.2 PureTech 82	SXHMR6	1.2	61	3	03.19-	EB2FA	1,0	LZKR6AI-10G	97999		
C3 1.2 THP	SXHNPS, SXHNZ6, SXHNZT	1.2	81	3	07.16-	EB2DT	0,8	ILZKBR7B8G	97968		
C3 Aircross 1.2 PureTech 110	2RHNPJ, 2RHNPX, 2RHNZB, 2RHNZW	1.2	81	3	06.17-	EB2DT	0,8	ILZKBR7B8G	97968		
C3 1.2 PureTech 110	SXHNZ6	1.2	81	3	03.19-	EB2DT	0,8	ILZKBR7B8G	97968		
C3 Aircross 1.2 PureTech 130	2RHNSJ, 2RHNYH	1.2	96	3	07.17-	EB2DTS	0,8	ILZKBR7B8G	97968		
C3	FCKFVB, FCKFVC, FCKFVE, FCKFVF, FNKFVB, FNKFVC, FNKFVE, FNKFVF	1.4	54	4	02.02-12.09	TU3JP	0,9	BKR6EZ	4619	38	LPG 1
C3	SCKFT0, SCKFTC	1.4	54	4	11.09-	TU3A, TU3AE5	0,9	BKR6EZ	4619	38	LPG 1
C3		1.4	55	4	04.02-	TU3A-KFV	0,9	BKR6EZ	4619	38	LPG 1
C3 / Pluriel		1.4	55	4	04.02-	TU3JP-KFX, KFV	0,9	BKR6EZ	4619	38	LPG 1
C3 / Pluriel		1.4	55	4	.03-	TU3JP	0,9	BKR6EZ	4619	38	LPG 1
C3	FCKFUC	1.4	65	4	11.03-08.10	ET3J4	0,9	LZKAR7A	6799	54	
C3		1.4	66	4	10.03-	ET3J4-KFU	0,9	LZKAR7A	6799	54	
C3 1.4 LPG	SC8FN0	1.4	70	4	11.09-09.16	EP3C	0,8	PLZKBR7B8G	91530		
C3 Picasso 1.4 BiFuel	SH8FN0	1.4	70	4	06.11-	EP3C	0,8	PLZKBR7B8G	91530		
C3 1.4 VTi	SC8FR0	1.4	72	4	07.10-09.16	EP3C	0,8	PLZKBR7B8G	91530		
C3 / Pluriel		1.6	81	4	04.02-	TU5JP4-NFU	0,9	LFR6B	6677	47	LPG 7
C3 / Pluriel 16V		1.6	81	4	.03-	TU5JP4	0,9	LFR6B	6677	47	LPG 7
C3 Picasso 1.6 VTi	SH5FW0, SH5FW8	1.6	84	4	07.09-	EP6	0,8	PLZKBR7B8G	91530		
C3 1.6 VTi	SXNFPT	1.6	85	4	02.17-	EC5F	0,9	LFR6B	6677	47	LPG 7

C3 II

C3 II 1.0 PureTech VTi 68		1.0	50	3	03.12-	EB0	1,0	LZKR6AI-10G	97999		
C3 II 1.1		1.1	44	4	11.09-	TU1A	0,9	BKR6EZ	4619	38	LPG 1
C3 1.1 BiFuel	SCHFV0	1.1	44	4	11.10-	TU1A	0,9	BKR6EZ	4619	38	LPG 1
C3 II 1.2 PureTech VTi 82		1.2	60	3	03.12-	EB2	1,0	LZKR6AI-10G	97999		
C3 1.4 BiFuel	FCKFVBD	1.4	54	4	09.08-12.09	TU3JP	0,9	BKR6EZ	4619	38	LPG 1
C3 II 1.4		1.4	54	4	11.09-	TU3A	0,9	BKR6EZ	4619	38	LPG 1
C3 1.4 BiFuel	SCKFT0	1.4	54	4	07.10-	TU3A	0,9	BKR6EZ	4619	38	LPG 1
C3 1.4 LPG	SC8FN0	1.4	70	4	11.09-	EP3C	0,8	PLZKBR7B8G	91530		
C3 1.4 VTi	SC8FP0	1.4	70	4	11.09-	EP3C	0,8	PLZKBR7B8G	91530		
C3 II 1.4 95 VTi		1.4	72	4	11.09-	EP3C	0,8	PLZKBR7B8G	91530		
C3 1.4 VTi	SC8FR0	1.4	72	4	07.10-	EP3C	0,8	PLZKBR7B8G	91530		
C3 II 1.6 VTi 120		1.6	88	4	11.09-	EP6C	0,8	PLZKBR7B8G	91530		

C3 PICASSO

C3 Picasso 1.4 95 VTi		1.4	70	4	12.08-	EP3	0,8	PLZKBR7B8G	91530		
-----------------------	--	-----	----	---	--------	-----	-----	------------	-------	--	--





l kW C
Y
I



Stock-N°

VLINE

LPG/CNG

CITROËN

C3 PICASSO

C3 Picasso 1.4 BiFuel	SH8FN0	1.4	70	4	06.11-	EP3C	0,8	PLZKBR7B8G	91530		
C3 Picasso 1.6 VTi	SH5FW0, SH5FW8	1.6	85	4	07.09-	EP6	0,8	PLZKBR7B8G	91530		
C3 Picasso 1.6 120 VTI		1.6	88	4	02.09-	EP6	0,8	PLZKBR7B8G	91530		
C3 Picasso 1.6 VTi	SH5FS0, SH5FS8, SH5FW0	1.6	88	4	02.09-	EP6, EP6C	0,8	PLZKBR7B8G	91530		

C3 PLURIEL

C3 Pluriel	HBKFVB, HBKFVC	1.4	54	4	05.03-12.11	TU3JP	0,9	BKR6EZ	4619	38	LPG 1
C3 Pluriel	HBKFVB	1.4	55	4	07.03-12.11	TU3A	0,9	BKR6EZ	4619	38	LPG 1
C3 Pluriel 1.4	HBKFVB	1.4	55	4	07.03-12.11	TU3A	0,9	BKR6EZ	4619	38	LPG 1

C4

C4 Cactus 1.2 PureTech 82	OPHMZA	1.2	60	3	05.19-	EB2	1,0	LZKR6AI-10G	97999		
C4 Cactus 1.2 THP 110	OPHNPJ, OPHNZB, OPHNZW	1.2	81	3	09.14-	EB2DT, EB2DTM	0,8	ILZKBR7B8G	97968		
C4 Cactus 1.2 PureTech 110	OPHNPJ, OPHNZB, OPHNZW	1.2	81	3	05.19-	EB2DT, EB2DTM	0,8	ILZKBR7B8G	97968		
C4 SpaceTourer 1.2 PureTech 130	3DHNSR, 3DHNYM, 3DHNYT	1.2	96	3	04.18-	EB2DTS	0,8	ILZKBR7B8G	97968		
Grand C4 SpaceTourer 1.2 PureTech 130	3AHNSR, 3AHNYM, 3AHNYT, 3EHNSR, 3EHNYM, 3EHNYT	1.2	96	3	04.18-	EB2DTS	0,8	ILZKBR7B8G	97968		
C4 16V		1.4	65	4	11.04-	ET3J4-KFU	0,9	LZKAR7A	6799	54	
C4 1.4 VTi	NC5FR0	1.4	70	4	11.09-	EP3C	0,8	PLZKBR7B8G	91530		
C4 16V		1.6	81	4	11.04-	TU5JP4-NFU	0,9	LF6R6B	6677	47	LPG 7
C4 1.6 120 Vti		1.6	88	4	06.08-	EP6	0,8	PLZKBR7B8G	91530		
C4 1.6 VTi	LA5FWB, LA5FWF	1.6	88	4	06.08-07.11	EP6	0,8	PLZKBR7B8G	91530		
C4 1.6 VTi	LC5FWB, LC5FWF	1.6	88	4	06.08-07.11	EP6	0,8	PLZKBR7B8G	91530		
C4 1.6 VTi	NC5FS0, NC5FS9	1.6	88	4	11.09-	EP6C	0,8	PLZKBR7B8G	91530		
C4 1.6 BiFuel	NC5FS0	1.6	88	4	09.11-	EP6C	0,8	PLZKBR7B8G	91530		
C4 Grand Picasso 1.6 VTi	DA5FS0, DE5FS0	1.6	88	4	08.13-	EP6C	0,8	PLZKBR7B8G	91530		
C4 1.6 16V		1.6	103	4	06.08-	EP6DT	0,8	PLZKBR7B8G	91530		
C4 1.6 THP	LA5FTH	1.6	103	4	06.08-07.11	EP6DT	0,8	PLZKBR7B8G	91530		
C4	LARFNB	2.0	100	4	09.04-07.07	EW10J4	0,9	LF5R5B	7113	46	LPG 7
C4 1.6 THP	LC5FTF, LC5FTH	1.6	103	4	06.08-07.11	EP6DT	0,8	PLZKBR7B8G	91530		
C4	LCRFNB	2.0	100	4	09.04-07.07	EW10J4	0,9	LF5R5B	7113	46	LPG 7
C4 16V		2.0	100	4	11.04-	EW10J4 RFN	0,9	LF5R5B	7113	46	LPG 7
C4 Picasso 1.6 THP	UD5FTF	1.6	103	4	06.08-12.10	EP6DT	0,8	PLZKBR7B8G	91530		
C4 1.6 16V		1.6	110	4	06.08-	EP6DT	0,8	PLZKBR7B8G	91530		
C4 1.6 THP	LA5FXF, LA5FXH	1.6	110	4	06.08-07.11	EP6DT	0,8	PLZKBR7B8G	91530		
C4	LCRFJC, LCRFJF	2.0	103	4	09.04-07.11	EW10A	0,9	LF5R5B	7113	46	LPG 7
C4 1.6 THP	LC5FXH	1.6	110	4	06.08-07.11	EP6DT	0,8	PLZKBR7B8G	91530		
C4 16V		2.0	103	4	11.04-	EW10A	0,9	LF5R5B	7113	46	LPG 7
C4 Grand Picasso 1.6 THP	DA5FV8, DE5FV8	1.6	115	4	08.13-	EP6CDT	0,8	PLZKBR7B8G	91530		





l kW C
Y
I



Stock-N°

VLINE

LPG/CNG

CITROËN

C4

C4	LARFJB	2.0	103	4	10.06-12.07	EW10A	0,9	LFR5B	7113	46	LPG 7
C4	LARFKB	2.0	130	4	09.04-12.10	EW10J4S	0,9	LFR5B	7113	46	LPG 7
C4	LCRFKB	2.0	130	4	02.05-07.08	EW10J4S	0,9	LFR5B	7113	46	LPG 7
C4 2.0 16V		2.0		4	11.04-	EW10A	0,9	LFR5B	7113	46	LPG 7

C4 AIRCROSS

C4 Aircross 1.6		1.6	86	4	04.12-	4A92	1,1	DILFR5A11	93759		
C4	BUAFYU, BUAFYW, BUAFZM, BUAFZP	2.0	110	4	04.12-	4B11	0,8	FR6EI	2687		FR6EI

C4 CACTUS

C4 Cactus 1.2 VTi	OPHMUA	1.2	55	3	03.14-	EB2D	1,0	LZKR6AI-10G	97999		
C4 Cactus 1.2 VTi	OPHMZA, OPHMZB	1.2	60	3	09.14-	EB2	1,0	LZKR6AI-10G	97999		

C4 GRAND PICASSO

C4 Grand Picasso 1.6 120 Vti		1.6	88	4	06.08-	EP6	0,8	PLZKBR7B8G	91530		
C4 Grand Picasso 1.6 VTi	UA5FWC, UF5FWC	1.6	88	4	06.08-08.13	EP6	0,8	PLZKBR7B8G	91530		
C4 Grand Picasso 1.6 VTi	DA5FS0, DE5FS0	1.6	88	4	08.13-	EP6C	0,8	PLZKBR7B8G	91530		
C4 Grand Picasso 1.6 16V		1.6	103	4	06.08-	EP6DT	0,8	PLZKBR7B8G	91530		
C4 Grand Picasso 1.6 THP	UA5FTF, UF5FTF	1.6	103	4	06.08-12.10	EP6DT	0,8	PLZKBR7B8G	91530		
C4 Grand Picasso 1.6 16V		1.6	110	4	06.08-	EP6DT	0,8	PLZKBR7B8G	91530		
C4 Grand Picasso 1.6 THP	UA5FX8, UA5FXH, UF5FX8, UF5FXH	1.6	110	4	06.08-08.13	EP6DT	0,8	PLZKBR7B8G	91530		
C4 Grand Picasso 1.6 155 THP		1.6	115	4	08.10-	EP6CDT	0,8	PLZKBR7B8G	91530		
C4 Grand Picasso 1.8i 16V		1.8		4	09.06-	EW7A	0,9	LFR5B	7113	46	LPG 7
C4 Grand Picasso 2.0		2.0	105	4	09.06-	EW10A	0,9	LFR5B	7113	46	LPG 7
C4 Grand Picasso 2.0 16V		2.0		4	09.06-	EW10A	0,9	LFR5B	7113	46	LPG 7

C4 II

C4 II 1.4 VTi 95		1.4	70	4	11.09-	EP3C	0,8	PLZKBR7B8G	91530		
C4 II 1.6 VTi 120		1.6	88	4	11.09-	EP6C	0,8	PLZKBR7B8G	91530		
C4 II 1.6 155 THP		1.6	115	4	11.09-	EP6CDT	0,8	PLZKBR7B8G	91530		

C4 PICASSO

C4 Picasso 1.6 120 VTi		1.6	88	4	06.08-	EP6	0,8	PLZKBR7B8G	91530		
C4 Picasso 1.6 VTi	UD5FS8, UD5FWC	1.6	88	4	06.08-08.13	EP6, EP6C	0,8	PLZKBR7B8G	91530		
C4 Picasso 1.6 VTi	DD5FS0	1.6	88	4	02.13-	EP6C	0,8	PLZKBR7B8G	91530		
C4 Picasso 1.6 16V		1.6	103	4	06.08-	EP6DT	0,8	PLZKBR7B8G	91530		
C4 Picasso 1.6 THP	UD5FTF	1.6	103	4	06.08-12.10	EP6DT	0,8	PLZKBR7B8G	91530		
C4 Picasso 1.6 16V		1.6	110	4	06.08-	EP6DT	0,8	PLZKBR7B8G	91530		
C4 Picasso 1.6 THP	UD5FXH	1.6	110	4	06.08-08.13	EP6DT	0,8	PLZKBR7B8G	91530		
C4 Picasso 1.6 155 THP		1.6	115	4	08.10-	EP6CDT	0,8	PLZKBR7B8G	91530		
C4	UD6FYC	1.8	92	4	02.07-12.11	EW7A	0,9	LFR5B	7113	46	LPG 7
C4 Picasso 1.8 BiFuel	UD6FYC	1.8	92	4	02.07-12.10	EW7A	0,9	LFR5B	7113	46	LPG 7
C4 Picasso 1.8i 16V		1.8		4	02.07-	EW7A	0,9	LFR5B	7113	46	LPG 7
C4 Picasso 2.0		2.0	105	4	02.07-	EW10A	0,9	LFR5B	7113	46	LPG 7
C4 Picasso 2.0 16V		2.0		4	02.07-	EW10A	0,9	LFR5B	7113	46	LPG 7





l kW C
Y
I



Stock-N°

VLINE

LPG/CNG

CITROËN

C4 PICASSO II

C4 Picasso II 1.6 VTi 120	1.6	88	4	02.13-	EP6C	0,8	PLZKBR7B8G	91530		
C4 Picasso II 1.6 THP 155	1.6	115	4	02.13-	EP6CDT	0,8	PLZKBR7B8G	91530		

C5

C5 1.6 VTi	RW5FS8, RW5FSA	1.6	88	4	07.10-	EP6C	0,8	PLZKBR7B8G	91530		
C5 Estate/Break 1.6 THP	RW5FN8, RW5FNA	1.6	110	4	04.09-	EP6CDT	0,8	PLZKBR7B8G	91530		
C5 1.6 THP	RD5FN8, RD5FNA	1.6	110	4	07.10-	EP6CDT	0,8	PLZKBR7B8G	91530		
C5	DC6FZB, DC6FZE	1.8	85	4	05.01-08.04	EW7J4	0,9	LFR5B	7113	46	LPG 7
C5	RC6FZB	1.8	85	4	09.04-08.05	EW7J4	0,9	LFR5B	7113	46	LPG 7
C5		1.8	86	4	06.02-	EW7J4 6FZ	0,9	LFR5B	7113	46	LPG 7
C5	RC6FYB	1.8	92	4	09.05-01.08	EW7A	0,9	LFR5B	7113	46	LPG 7
C5	RD6FYC	1.8	92	4	02.08-	EW7A	0,9	LFR5B	7113	46	LPG 7
C5		2.0	100	4	10.00-	EW10J4 RFN	0,9	LFR5B	7113	46	LPG 7
C5	DCRFNC, DCRFNF	2.0	100	4	10.00-08.04	EW10J4	0,9	LFR5B	7113	46	LPG 7
C5	RCRFJB, RCRFJC	2.0	103	4	09.04-01.08	EW10A	0,9	LFR5B	7113	46	LPG 7
C5	RDRFJC, RDRFJF	2.0	103	4	02.08-	EW10A	0,9	LFR5B	7113	46	LPG 7
C5 2.0 Bioflex	RDRFJF	2.0	103	4	02.08-12.12	EW10A	0,9	LFR5B	7113	46	LPG 7
C5 2.0 Bioflex	RWRFJF	2.0	103	4	02.08-	EW10A	0,9	LFR5B	7113	46	LPG 7
C5		2.0	105	4	09.04-	EW10A	0,9	LFR5B	7113	46	LPG 7
C5 2.0 16V		2.0		4	09.04-	EW10A	0,9	LFR5B	7113	46	LPG 7
C5	DCXFXC, DCXFXF	3.0	152	6	10.00-08.04	ES9J4S	1,1	PLFR5A-11	6240		LPG 7
C5		3.0	154	6	10.00-	ES9J4S XFX	1,1	PLFR5A-11	6240		LPG 7

C5 ESTATE/BREAK

C5	DE6FZB, DE6FZE	1.8	85	4	05.01-08.04	EW7J4	0,9	LFR5B	7113	46	LPG 7
C5	RE6FZB	1.8	85	4	09.04-08.05	EW7J4	0,9	LFR5B	7113	46	LPG 7
C5	RE6FYB	1.8	92	4	09.05-01.08	EW7A	0,9	LFR5B	7113	46	LPG 7
C5	RW6FYC	1.8	92	4	02.08-	EW7A	0,9	LFR5B	7113	46	LPG 7
C5	DERFNC, DERFNF	2.0	100	4	03.01-08.04	EW10J4	0,9	LFR5B	7113	46	LPG 7
C5	RCRFJC, RERFJB, RERFJC	2.0	103	4	09.04-01.08	EW10A	0,9	LFR5B	7113	46	LPG 7
C5	RERFJB, RERFJC	2.0	103	4	11.04-01.08	EW10A	0,9	LFR5B	7113	46	LPG 7
C5	RWRFJC, RWRFJF	2.0	103	4	02.08-	EW10A	0,9	LFR5B	7113	46	LPG 7
C5	DEXFXC, DEXFXF	3.0	152	6	03.01-08.04	ES9J4S	1,1	PLFR5A-11	6240		LPG 7
C5	DEXFXH, DEXFXR	3.0	173	6	06.03-08.04	ES9J4SHP	1,1	PLFR5A-11	6240		LPG 7

C5 III

C5 III 1.6 120 Vti		1.6	88	4	07.10-	EP6C	0,8	PLZKBR7B8G	91530		
C5 III 1.6 155 THP		1.6	115	4	06.09-	EP6CDT	0,8	PLZKBR7B8G	91530		
C5 III 1.8		1.8	92	4	02.08-	EW7A	0,9	LFR5B	7113	46	LPG 7
C5 III 2.0		2.0	103	4	02.08-	EW10A	0,9	LFR5B	7113	46	LPG 7
C5 III 3.0 V6		3.0	155	6	02.08-	ES9A	1,1	PLFR5A-11	6240		LPG 7

C6

C6 3.0 V6		3.0	155	6	08.05-	ES9A, ES9J4S	1,1	PLFR5A-11	6240		LPG 7
-----------	--	-----	-----	---	--------	--------------	-----	-----------	------	--	-------





l kW C
Y
I



Stock-N°

VLINE

LPG/CNG

CITROËN

C8

C8		2.0	100	4	06.02-	EW10J4 RFN	0,9	LFR5B	7113	46	LPG 7
C8		2.0	104	4	09.05-	EW10A	0,9	LFR5B	7113	46	LPG 7
C8 2.0 16V		2.0		4	09.05-	EW10A	0,9	LFR5B	7113	46	LPG 7
C8		2.2	118	4	06.02-	EW12J4-3FZ	0,9	LFR5B	7113	46	LPG 7
C8 V6		3.0	150	6	10.02-	ES9J4S	1,1	PLFR5A-11	6240		LPG 7

C-CROSSER

C-Crosser 2.0 Mivec	VUMMCC, VUMMCF, VMMCC, VMMCF	2.0	108	4	11.10-12.12	4B11	0,8	FR6EI	2687		FR6EI
C-Crosser		2.4	125	4	09.07-	VUSFZC, VUSFZF, VVSFZC, VVSFZF	0,8	FR5EI	1313		FR6EI
C-Crosser Enterprise 2.4 Mivec (Euro 4)	VUSFZC, VUSFZF, VVSFZC, VVSFZF	2.4	125	4	01.09-12.12	4B12	0,8	FR5EI	1313		FR6EI

C-ELYSEE

C-Elysée 1.2 VTi 72		1.2	52	3	.12-	EB2M	1,0	LZKR6AI-10G	97999		
C-Elysée 1.2 VTi	DDHMZ6	1.2	60	3	12.14-	EB2F	1,0	LZKR6AI-10G	97999		
C-Elysée 1.2 PureTech 82	DDHMRP	1.2	61	3	02.18-	EB2FA	1,0	LZKR6AI-10G	97999		
C-Elysée 1.6 115 VTi		1.6	84	4	.12-	EC5	0,8	PLZKBR7B8G	91530		
C-Elysée 1.6 VTi	DDNFP0, DDNFP9, DDNFPT	1.6	85	4	06.12-	EC5	0,9	LFR6B	6677	47	LPG 7

DISPATCH

Dispatch	BZRFNC, BZRFNF	2.0	102	4	03.00-10.06	EW10J4	0,9	LFR5B	7113	46	LPG 7
Dispatch	VF7RFHC	2.0	103	4	03.09-03.11	EW10A	0,9	LFR5B	7113	46	LPG 7

DS3

DS3 1.2 PureTech VTi 82		1.2	60	3	.11-	EB2	1,0	LZKR6AI-10G	97999		
DS3 1.4 95 Vti		1.4	70	4	04.10-	EP3C	0,8	PLZKBR7B8G	91530		
DS3 1.6 120 Vti		1.6	88	4	04.10-	EP6C	0,8	PLZKBR7B8G	91530		
DS3 1.6 VTi	SB5FS0, SB5FS9	1.6	88	4	01.13-07.15	EP6C	0,8	PLZKBR7B8G	91530		
DS3 1.6 THP	SA5FX8	1.6	110	4	01.10-07.15	EP6DT	0,8	PLZKBR7B8G	91530		
DS3 1.6 THP	SB5FN8, SB5FX8	1.6	110	4	01.13-07.15	EP6CDT, EP6DT	0,8	PLZKBR7B8G	91530		
DS3 1.6 155 THP		1.6	115	4	04.10-	EP6DT, EP6CDT	0,8	PLZKBR7B8G	91530		
DS3 1.6 THP	SB5FRH	1.6	115	4	01.13-07.15	EP6DT	0,8	PLZKBR7B8G	91530		
DS3 1.6 THP Racing	SA5FF8	1.6	149	4	02.11-07.15	EP6DTS	0,8	ILZKR8C8G	90909		
DS3 1.6 THP Racing	SB5FD8	1.6	149	4	03.14-07.15	EP6DTS	0,8	ILZKR8C8G	90909		
DS3 1.6 THP Racing	SA5FD8, SB5FD8	1.6	152	4	02.11-07.15	EP6DTS	0,8	ILZKR8C8G	90909		

DS4

DS4 1.6 120 Vti		1.6	88	4	04.11-	EP6C	0,8	PLZKBR7B8G	91530		
DS4 1.6 VTi	NX5FS0	1.6	88	4	04.11-07.15	EP6C	0,8	PLZKBR7B8G	91530		
DS4 1.6 THP	NX5FEA	1.6	110	4	04.11-07.15	EP6CDTMD	0,8	ILZKBR7B8G	97968		
DS4 1.6 155 THP		1.6	115	4	04.11-	EP6DT, EP6CDT	0,8	PLZKBR7B8G	91530		
DS4 1.6 THP	NX5FV8	1.6	115	4	04.11-07.15	EP6CDT	0,8	PLZKBR7B8G	91530		
DS4 1.6 200 THP		1.6	147	4	04.11-	EP6CDTX	0,8	ILZKBR7B8G	97968		

DS5

DS5 1.6 THP	KF5FE8	1.6	110	4	11.11-07.15	EP6CDTMD	0,8	ILZKBR7B8G	97968		
DS5 1.6 155 THP		1.6	115	4	11.11-	EP6CDT	0,8	PLZKBR7B8G	91530		





l kW C
Y I



Stock-N°

VLINE

LPG/CNG

CITROËN

DS5

DS5 1.6 THP	KF5FM8	1.6	121	4	01.12-07.15	EP6CDTM	0,8	ILZKBR7B8G	97968		
DS5 1.6 200 THP		1.6	147	4	11.11-	EP6CDTX	0,8	ILZKBR7B8G	97968		

EVASION

Evasion		1.8	72	4	09.96-06.00	XU7JP LFW	0,8	BKR5EK	7956	23	LPG 1
Evasion		2.0	89	4	07.94-03.95	XU10J2 RFU	0,9	BCPR5ES	6130	32	LPG 3
Evasion		2.0	90	4	04.95-05.00	XU10J2 RFU	0,8	BKR5EK	7956	23	LPG 1
Evasion		2.0	101	4	06.00-	EW10J4 RFR	0,9	LFR5B	7113	46	LPG 7
Evasion Turbo		2.0	110	4	09.94-05.00	XU10J2TE RGX	0,9	BKR6EK	2288	20	LPG 1

JUMPER

Jumper		2.0	81	4	04.95-	XU10.J2U RFW	0,9	BKR6EK	2288	20	LPG 1
Jumper		2.0	81	4	-03.95	XU10.J2U RFW	0,9	BCPR6ES	2330	12	LPG 3

JUMPY

Jumpy		1.6	59	4	10.95-	1580 SPI 220A2.000	0,9	BCPR7ES	3330		BCPR7EIX
Jumpy 2.0 Hdi		2.0	100	4	06.01-	EW10J4 RFN	0,9	LFR5B	7113	46	LPG 7
Jumpy 2.0 16V		2.0	105	4	12.06-	EW10A	0,9	LFR5B	7113	46	LPG 7

NÉMO

Nemo	AAKFTB, AAKFVB	1.4	54	4	11.07-	TU3AE5	0,9	BKR6EZ	4619	38	LPG 1
Nemo	ABKFTB, ABKFVB, AJKFTB, AJKFVB	1.4	54	4	04.09-	TU3A	0,9	BKR6EZ	4619	38	LPG 1
Nemo 1.4		1.4	54	4	02.08-	KFV (TU3A)	0,9	BKR6EZ	4619	38	LPG 1

SAXO I

Saxo I		1.0	37	4	02.96-09.99	TU9M CDZ	0,8	BKR5EK	7956	23	LPG 1
Saxo I		1.1	44	4	02.96-08.99	TU1M + HDZ	0,9	BKR6EK	2288	20	LPG 1
Saxo I		1.4	55	4	02.96-08.99	TU3JP KFW, TU3JP + KFX	0,9	BKR6EK	2288	20	LPG 1
Saxo I 1.6		1.6	66	4	07.98-08.99	TU5JP-NFZ	0,9	BKR6EK	2288	20	LPG 1

SAXO II

Saxo II		1.0	37	4	09.99-12.00	TU9M CDZ	0,8	BKR5EK	7956	23	LPG 1
Saxo II		1.1	44	4	09.99-	TU1M + HDZ	0,9	BKR6EK	2288	20	LPG 1
Saxo II		1.1	44	4	06.00-	TU1JP HFX	0,9	BKR6EZ	4619	38	LPG 1
Saxo II		1.4	55	4	09.99-	TU3JP KFW, TU3JP + KFX	0,9	BKR6EZ	4619	38	LPG 1
Saxo II 1.6	S0NFZD, S0NFZF, S1NFZD	1.6	65	4	05.96-06.03	TU5JP-NFZ	0,9	BKR6EZ	4619	38	LPG 1
Saxo II 1.6		1.6	66	4	09.99-12.00	TU5JP-NFZ	0,9	BKR6EZ	4619	38	LPG 1
Saxo II 1.6		1.6	66	4	01.01-	TU5JP-NFT	0,9	BKR6EZ	4619	38	LPG 1
Saxo II 1.6	S6NFTB	1.6	74	4	02.01-04.04	TU5JP-NFT	0,9	BKR6EZ	4619	38	LPG 1
Saxo II 1.6		1.6	88	4	03.01-04.02	TU5JP-NFX	0,9	BKR6EK	2288	20	LPG 1

SYNERGIE

Synergie	AFRFNC, AFRFNF	2.0	100	4	09.00-02.03	EW10J4	0,9	LFR5B	7113	46	LPG 7
----------	-------------------	-----	-----	---	-------------	--------	-----	-------	------	----	-------

XANTIA

Xantia		1.6	66	4	06.93-05.95	XU5JP BFZ	0,9	BCPR5ES	6130	32	LPG 3
Xantia		1.6	66	4	06.95-	XU5JP BFZ	0,8	BKR5EK	7956	23	LPG 1
Xantia		1.8	66	4	01.98-	XU7JB LFX	0,9	BKR6EK	2288	20	LPG 1
Xantia		1.8	76	4	07.93-03.95	XU7JP LFZ	0,9	BCPR5ES	6130	32	LPG 3





l kW C
Y
I



Stock-N°

VLINE

LPG/CNG

CITROËN

XANTIA

Xantia	1.8	76	4	04.95-	XU7JP LFZ	0,8	BKR5EK	7956	23	LPG 1
Xantia 16V	1.8	82	4	07.95-	XU7JP4 LFY	0,8	BKR5EK	7956	23	LPG 1
Xantia	2.0	90	4	03.93-05.95	XU10J2C RFX	0,9	BCPR5ES	6130	32	LPG 3
Xantia	2.0	90	4	06.95-	XU10J2C RFX	0,8	BKR5EK	7956	23	LPG 1
Xantia 16V	2.0	99	4	06.95-	XU10J4R RFV	0,8	BKR5EK	7956	23	LPG 1
Xantia turbo	2.0	110	4	07.96-	XU10J2TE RGX	0,9	BKR6EK	2288	20	LPG 1
Xantia 16V	2.0	112	4	.93-	XU10J4D	0,9	BKR6ES	3783	28	LPG 1
Xantia	3.0	142	6	03.97-	ES9J4 XFZ	0,9	BKR6EK	2288	20	LPG 1

XM

XM	2.0	99	4	07.94-12.00	XU10J4R RFV	0,8	BKR5EK	7956	23	LPG 1
XM Turbo	2.0	110	4	11.92-12.00	XU10J2TE RGX	0,9	BKR6EK	2288	20	LPG 1
XM	2.0	110	4	.96-	XU10J2CTE	0,9	BKR6EK	2288	20	LPG 1
XM	2.0		4	05.89-12.92	XU102C-R2A	0,9	BCP6ES	4930	17	LPG 3
XM	2.0		4	05.89-12.92	XU10J2 R6A	0,9	BCPR6ES	2330	12	LPG 3
XM	2.0		4	05.92-12.00	XU10J2 RFZ Cat.	0,9	BCPR5ES	6130	32	LPG 3
XM 16V	2.0		4	07.94-		0,9	BCPR6ES	2330	12	LPG 3
XM V6 24V	3.0	140	6	01.97-12.00	ES9J4-XFZ	0,9	BKR6EK	2288	20	LPG 1
XM	3.0		6	05.89-06.94	ZPJ-SFZ	0,9	BCPR6ET	2197		LPG 3
XM	3.0		6	07.94-06.97	ZPJ-UFZ	0,9	BCPR6ET	2197		LPG 3
XM V6 24V	3.0		6	07.94-07.97	ZPJ4-UKZ	0,9	BCPR7ET	2164		BCPR7EIX

XSARA

Xsara 1.4 BiFuel	N1KFX	1.4	55	4	07.97-08.00	TU3JP	0,9	BKR6EZ	4619	38	LPG 1
Xsara		1.4	55	4	09.97-08.00	TU3JP KFX	0,9	BKR6EK	2288	20	LPG 1
Xsara Estate/Break 1.4	N2KFX	1.4	55	4	10.97-08.05	TU3JP	0,9	BKR6EZ	4619	38	LPG 1
Xsara 1.4	N0KFX	1.4	55	4	03.98-03.05	TU3JP	0,9	BKR6EZ	4619	38	LPG 1
Xsara 1.4	N3KFX	1.4	55	4	05.98-10.04	TU3JP	0,9	BKR6EZ	4619	38	LPG 1
Xsara Estate/Break 1.4 BiFuel	N2KFX	1.4	55	4	05.98-08.00	TU3JP	0,9	BKR6EZ	4619	38	LPG 1
Xsara 1.4 BiFuel	N3KFX	1.4	55	4	06.99-08.00	TU3JP	0,9	BKR6EZ	4619	38	LPG 1
Xsara Estate/Break 1.4	N4KFX	1.4	55	4	09.00-03.05	TU3JP	0,9	BKR6EZ	4619	38	LPG 1
Xsara 1.6	N1NFZ	1.6	65	4	07.97-08.00	TU5JP	0,9	BKR6EZ	4619	38	LPG 1
Xsara 1.6	N0NFZ	1.6	65	4	02.98-08.00	TU5JP	0,9	BKR6EZ	4619	38	LPG 1
Xsara Estate/Break 1.6	N2NFZ	1.6	65	4	05.98-08.00	TU5JP	0,9	BKR6EZ	4619	38	LPG 1
Xsara		1.6	66	4	09.97-08.00	TU5JP-NFZ	0,9	BKR6EK	2288	20	LPG 1
Xsara Picasso 1.6	CHNFVB	1.6	74	4	04.01-10.04	TU5JP	0,9	BKR6EZ	4619	38	LPG 1
Xsara		1.8	66	4	09.97-08.00	XU7JB LFX	0,9	BKR6EK	2288	20	LPG 1
Xsara 16V		1.8	75	4	09.97-08.00	XU7JP LFZ	0,8	BKR5EK	7956	23	LPG 1
Xsara 16V		1.8	82	4	09.97-08.00	XU7JP4 LFY	0,8	BKR5EK	7956	23	LPG 1
Xsara 2.0	N0RFS	2.0	120	4	06.97-08.00	XU10J4RS	0,9	BCPR6ET	2197		LPG 3
Xsara 16V		2.0	120	4	09.97-08.00	XU10J4RS RFS	0,9	BKR6EK	2288	20	LPG 1

XSARA II

Xsara 2		1.4	55	4	09.00-	TU3JP KFW	0,9	BKR6EZ	4619	38	LPG 1
Xsara 2 16V		1.6	81	4	09.00-	TU5JP4-NFU	0,9	LFR6B	6677	47	LPG 7
Xsara 2 16V		1.8	86	4	09.00-	EW7J4 6FZ	0,9	LFR5B	7113	46	LPG 7
Xsara 2 16V		2.0	100	4	09.00-	EW10J4 RFN	0,9	LFR5B	7113	46	LPG 7
Xsara 2 2.0i 16V VTS		2.0	123	4	09.00-	XU10J4RS RFS	0,9	BKR5EZ	7642	36	LPG 1





l kW C
Y
I



Stock-N°

VLINE

LPG/CNG

CITROËN

XSARA PICASSO

Xsara Picasso	1.6	66	4	12.99-	TU5JP-NFZ, TU5JP-NFV	0,9	BKR6EZ	4619	38	LPG 1
Xsara Picasso 1.8i 16V	1.8	86	4	12.99-	EW7J4-6FZ	0,9	LFR5B	7113	46	LPG 7
Xsara Picasso	2.0	101	4	09.00-	EW10J4 RFM	0,9	LFR5B	7113	46	LPG 7

ZX

ZX 1.1	1.1	40	4	03.91-06.92	TU1	0,9	BCP5ES	7496	16	LPG 3	
ZX 1.1	1.1	44	4	07.92-03.96	TU1M HDZ	0,9	BCPR5ES	6130	32	LPG 3	
ZX 1.1	1.1	44	4	04.96-	TU1M	0,8	BKR5EK	7956	23	LPG 1	
ZX 1.1i	1.1	44	4	04.96-	TU1M HDZ	0,8	BKR5EK	7956	23	LPG 1	
ZX 1.4	1.4	55	4	03.91-12.92	TU32 K2C	0,9	BCP5ES	7496	16	LPG 3	
ZX 1.4	1.4	55	4	03.91-06.97	TU3MC KDX	0,9	BCPR6ES	2330	12	LPG 3	
ZX	N2	1.4	55	4	03.91-05.98	TU3M	0,9	BKR6EK	2288	20	LPG 1
ZX 1.4	1.4	55	4	07.92-06.97	TU3MC KDY Cat.	0,9	BKR6EK	2288	20	LPG 1	
ZX 1.4	1.4	55	4	07.97-	TU3JP KFX, TU3JP-KFX	0,9	BKR6EK	2288	20	LPG 1	
ZX 1.6	1.6	65	4	03.91-06.93	XU5M BDY cat.	0,9	BCPR5ES	6130	32	LPG 3	
ZX 1.6	1.6	66	4	07.93-06.95	XU5JP Cat.	0,9	BCPR5ES	6130	32	LPG 3	
ZX 1.6i	1.6	66	4	07.93-06.95	XU5JP BFZ	0,9	BCPR5ES	6130	32	LPG 3	
ZX 1.6	1.6	66	4	07.95-07.98	TU5JP	0,8	BKR5EK	7956	23	LPG 1	
ZX 1.6i	1.6	66	4	07.95-07.98	XU5JP BFZ	0,8	BKR5EK	7956	23	LPG 1	
ZX 1.8	1.8	76	4	07.92-06.95	XU7JP LFZ	0,9	BCPR5ES	6130	32	LPG 3	
ZX 1.8	1.8	76	4	07.95-	XU7JP Cat.	0,8	BKR5EK	7956	23	LPG 1	
ZX 1.8i	1.8	76	4	07.95-	XU7JP LFZ	0,8	BKR5EK	7956	23	LPG 1	
ZX 1.8	1.8	82	4	07.97-	XU7JP4 LFY	0,8	BKR5EK	7956	23	LPG 1	
ZX 1.9	1.9	88	4	07.92-	XU9JA DKZ Cat.	0,9	BCPR5ES	6130	32	LPG 3	
ZX 1.9	1.9	96	4	03.91-06.92	XU9JA D6A	0,9	BCP6ES	4930	17	LPG 3	
ZX 2.0	2.0	90	4	07.92-03.96	XU10J2C	0,9	BCPR5ES	6130	32	LPG 3	
ZX 2.0i	2.0	90	4	07.92-03.96	XU10J2 RFX	0,9	BCPR5ES	6130	32	LPG 3	
ZX 2.0	2.0	90	4	04.96-	XU10J2C Cat.	0,8	BKR5EK	7956	23	LPG 1	
ZX 2.0i	2.0	90	4	04.96-	XU10J2 RFX	0,8	BKR5EK	7956	23	LPG 1	
ZX 2.0	2.0	110	4	11.92-06.96	XU10J4D RFT Cat.	0,9	BKR6EK	2288	20	LPG 1	
ZX 2.0	2.0	110	4	07.94-06.96	XU10J4D	0,9	BCPR6ES	2330	12	LPG 3	
ZX 2.0	2.0	110	4	07.96-	XU10J4RS RFS	0,9	BKR5EZ	7642	36	LPG 1	
ZX 2.0	N2	2.0	120	4	05.96-06.97	XU10J4RS	0,9	BCPR6ET	2197	LPG 3	
ZX 2.0	N2	2.0	122	4	09.96-10.97	XU10J4RS	0,9	BCPR6ET	2197	LPG 3	

DACIA

DOKKER

Dokker 1.2 TCe	FE, KE	1.2	85	4	11.12-	H5F 402	0,7	ILKAR7F7G	90061		
Dokker 1.2 TCe	KEAY, KEM0, FEAY	1.2	85	4	11.12-	H5F408	0,7	ILKAR7F7G	90061		
Dokker 1.3 TCe 100	KENU, FENU	1.3	75	4	08.19-	H5H470	0,7	SILZKFR8D7G	90912		
Dokker 1.3 TCe 130	KENE, FENE	1.3	96	4	03.19-	H5H470	0,7	SILZKFR8D7G	90912		
Dokker 1.6 16V	FE, KE	1.6	61	4	11.12-	K7M812	0,9	BKR6EK	2288	20	LPG 1
Dokker 1.6 16V LPG	FE, KE	1.6	61	4	11.13-	K7M812	0,9	BKR6EK	2288	20	LPG 1
Dokker 1.6 SCe	KEAV, FEAV	1.6	75	4	04.15-	H4M738	0,9	LZKAR7D-9D	94951		
Dokker 1.6 LPG	KENB	1.6	80	4	08.18-	H4M740	0,9	LZKAR7D-9D	94951		





l kW C
Y
I



Stock-N°

VLINE

LPG/CNG

DACIA

DUSTER

Duster 1.6	HSA5, HSA8, HSA9, HSM, HSMR	1.6	77	4	03.10-01.18	K4M490, K4M606, K4M646, K4M690	0,9	BKR6EK	2288	20	LPG 1
Duster 1.6 Hi-Flex	HSAM, HSAS	1.6	77	4	01.11-01.18	K4M696	0,9	BKR6EK	2288	20	LPG 1

DUSTER II

Duster 1.2 TCe	HS	1.2	92	4	10.13-	H5F402	0,7	ILKAR7F7G	90061		
Duster 1.6	HS	1.6	77	4	03.10-	K4M690, K4M696	0,9	BKR6EK	2288	20	LPG 1
Duster 1.6 LPG	HS	1.6	77	4	03.10-	K4M616, K4M642	0,9	BKR6EK	2288	20	LPG 1
Duster 1.6 SCe LPG	HSAV	1.6	80	4	06.15-	H4M740	0,9	LZKAR7D-9D	94951		
Duster 1.6 SCe	HSAV	1.6	84	4	06.15-	H4M730, H4M738	0,9	LZKAR7D-9D	94951		
Duster 1.6 SCe	HSJA	1.6	84	4	06.15-	H4M430	0,9	LZKAR7D-9D	94951		

DUSTER III

Duster 1.2 TCe 125	HMMMA	1.2	92	4	10.17-	H5F408, H5F410	0,7	ILKAR7F7G	90061		
Duster 1.3 TCe 130	HMMF	1.3	96	4	01.19-	H5H470, H5H480	0,7	SILZKFR8D7G	90912		
Duster 1.3 TCe 150	HMM3	1.3	110	4	01.19-	H5H470, H5H480	0,7	SILZKFR8D7G	90912		

LODGY

Lodgy 1.2 TCe	JS	1.2	85	4	03.12-	H5F 402	0,7	ILKAR7F7G	90061		
Lodgy 1.2 TCe	JSAY, JSM0	1.2	85	4	03.12-	H5F408	0,7	ILKAR7F7G	90061		
Lodgy 1.3 TCe 100	JSNU	1.3	75	4	01.19-	H5H470	0,7	SILZKFR8D7G	90912		
Lodgy 1.3 TCe 130	JSNE	1.3	96	4	01.19-	H5H470	0,7	SILZKFR8D7G	90912		
Lodgy 1.6	JS	1.6	61	4	03.12-	K7M812	0,9	BKR6EK	2288	20	LPG 1
Lodgy 1.6 LPG	JS	1.6	61	4	11.13-	K7M812	0,9	BKR6EK	2288	20	LPG 1
Lodgy 1.6 SCe	JSAV	1.6	75	4	04.15-	H4M738	0,9	LZKAR7D-9D	94951		
Lodgy 1.6 SCe LPG	JSAV	1.6	75	4	04.15-	H4M740	0,9	LZKAR7D-9D	94951		
Lodgy 1.6 SCe LPG	JSNB	1.6	80	4	08.18-	H4M740	0,9	LZKAR7D-9D	94951		
Lodgy Stepway 1.6 SCe LPG	JSNB	1.6	80	4	05.19-	H4M740	0,9	LZKAR7D-9D	94951		

LOGAN

Logan 0.9 TCe	L8M1, L8MA	0.9	66	3	11.12-	H4B400, H4B408	0,7	ILKAR7F7G	90061		
Logan MCV 0.9 TCe	K8M1, K8MA	0.9	66	3	04.13-	H4B400, H4B408	0,7	ILKAR7F7G	90061		
Logan MCV Stepway 0.9 TCe	K8M1	0.9	66	3	09.16-	H4B408	0,7	ILKAR7F7G	90061		
Logan MCV 1.0 SCe	K8JC	1.0	54	3	12.16-	B4D400	0,9	LZKAR7B	5942		
Logan 1.0 SCe	L8JC	1.0	54	3	01.17-	B4D400	0,9	LZKAR7B	5942		
Logan 1.0 Hi-Flex	LS0R, LS1G	1.0	56	4	01.11-10.12	D4D760	0,9	LZKAR7B	5942		
Logan 1.2 LPG	L8MG, L8MP	1.2	53	4	02.13-	D4F734	0,9	LZKAR7B	5942		
Logan MCV 1.2 LPG	K8MG, K8MP	1.2	53	4	02.13-	D4F734	0,9	LZKAR7B	5942		
Logan MCV 1.2	K8J3, K8MG, K8MP	1.2	54	4	05.15-	D4F732	0,9	LZKAR7B	5942		
Logan 1.4	LS0A, LS0C, LS0E, LS0G	1.4	55	4	08.04-12.12	K7J710	0,9	BKR6EK	2288	20	LPG 1
Logan MCV 1.4	KS0A, KS0E, KS0G	1.4	55	4	08.06-12.12	K7J710	0,9	BKR6EK	2288	20	LPG 1
Logan 1.4	FS0A, FS0C, FS0E	1.4	55	4	10.07-12.12	K7J710	0,9	BKR6EK	2288	20	LPG 1
Logan MCV 1.6 LPG	KS0D, KS0F	1.6	62	4	08.06-06.13	K7M718	0,8	BKR5EK	7956	23	LPG 1
Logan MCV 1.6 LPG	KS0D, KS0F	1.6	62	4	08.06-06.13	K7M718	0,9	BKR6EK	2288	20	LPG 1
Logan 1.6	FS03	1.6	62	4	05.10-06.13	K7M800	0,9	BKR6EK	2288	20	LPG 1
Logan 1.6 LPG	FS03	1.6	62	4	05.10-12.12	K7M818	0,9	BKR6EK	2288	20	LPG 1
Logan MCV 1.6	K8JB	1.6	62	4	06.13-	K7M812	0,9	BKR6EK	2288	20	LPG 1





l kW C
Y I



Stock-N°

VLINE

LPG/CNG

DACIA

LOGAN

Logan 1.6	L8ME, L8MV	1.6	63	4	06.13-08.16	K7M812	0,9	BKR6EK	2288	20	LPG 1
Logan 1.6 LPG	LS0D, LS0F	1.6	64	4	08.04-03.11	K7M718	0,9	BKR6EK	2288	20	LPG 1
Logan 1.6	LS0B, LS0D, LS0F, LS0H	1.6	64	4	09.04-06.13	K7M710	0,8	BKR5EK	7956	23	LPG 1
Logan 1.6	LS0B, LS0D, LS0F, LS0H	1.6	64	4	09.04-06.13	K7M710	0,9	BKR6EK	2288	20	LPG 1
Logan MCV 1.6	KS0B, KS0D, KS0F	1.6	64	4	08.06-06.13	K7M710	0,8	BKR5EK	7956	23	LPG 1
Logan MCV 1.6	KS0B, KS0D, KS0F	1.6	64	4	08.06-06.13	K7M710	0,9	BKR6EK	2288	20	LPG 1
Logan 1.6	FS0B, FS0D, FS0F, FS1E	1.6	64	4	10.07-06.13	K7M710	0,8	BKR5EK	7956	23	LPG 1
Logan 1.6	FS0B, FS0D, FS0F, FS1E	1.6	64	4	10.07-06.13	K7M710	0,9	BKR6EK	2288	20	LPG 1
Logan 1.6	US0B, US0D, US0F, US0H, US11, US1E	1.6	64	4	03.08-12.12	K7M710	0,8	BKR5EK	7956	23	LPG 1
Logan 1.6	LS09, LS0L, LS0M, LS0P, LS0V, LS18, LS1S, LS1V, LS1Y	1.6	77	4	01.06-12.12	K4M690, K4M694, K4M696, K4M697, K4M698	0,9	BKR6EK	2288	20	LPG 1
Logan MCV 1.6	KS0L, KS0M, KS0P, KS1S	1.6	77	4	08.06-06.13	K4M690, K4M696, K4M697	0,9	BKR6EK	2288	20	LPG 1
Logan 1.6	US1Y	1.6	77	4	01.10-08.13	K4M690	0,9	BKR6EK	2288	20	LPG 1
Logan 1.6 Hi-Flex	LS1S	1.6	77	4	07.10-12.12	K4M696	0,9	BKR6EK	2288	20	LPG 1
Logan 1.6	L8M9, L8MT	1.6	77	4	01.13-	K4M842	0,9	BKR6EK	2288	20	LPG 1

LOGAN I

Logan I 1.2 16V	LS	1.2	55	4	02.06-	D4F732, D4F734	0,9	LZKAR7B	5942		
Logan I 1.2 16V LPG	LS	1.2	55	4	02.06-	D4F732, D4F734	0,9	LZKAR7B	5942		
Logan I 1.4 MPI	LS, FS	1.4	55	4	09.04-	K7J 710	0,9	BKR6E	6962	28	LPG 1
Logan I 1.4 MPI LPG	LS	1.4	55	4	02.06-	K7J710, K7J714	0,9	BKR6EK	2288	20	LPG 1
Logan I 1.6 MPI	LS, FS	1.6	62	4	05.10-12.12	K7M 800	0,9	BKR6EK	2288	20	LPG 1
Logan I 1.6 MPI (Renault Engine)	LS, FS	1.6	64	4	09.04-06.13	K7M710	0,9	BKR6E	6962	28	LPG 1
Logan I 1.6 16V	LS	1.6	77	4	02.06-	K4M690, K4M696	0,9	BKR6EK	2288	20	LPG 1

LOGAN II

Logan II 0.9 TCe 90	L8	0.9	66	3	11.12-	H4B 400	0,7	ILKAR7J7G	91121		
Logan II 1.2 16V	L8	1.2	55	4	11.12-	D4F732, D4F734	0,9	LZKAR7B	5942		
Logan II 1.2 16V LPG	L8	1.2	55	4	02.13-	D4F732, D4F734	0,9	LZKAR7B	5942		
Logan II 1.6	L8	1.6	60	4	04.14-	K7M812	0,9	BKR6EK	2288	20	LPG 1

LOGAN MCV I

Logan MCV I 1.4 MPI	KS	1.4	55	4	08.06-12.12	K7J 710	0,9	BKR6E	6962	28	LPG 1
Logan MCV I 1.6 MPI	KS	1.6	62	4	05.10-06.13	K7M 800	0,9	BKR6EK	2288	20	LPG 1
Logan MCV I 1.6	KS	1.6	64	4	08.06-06.13	K7M 710	0,9	BKR6EK	2288	20	LPG 1
Logan MCV I 1.6 LPG	KS	1.6	64	4	08.06-06.13	K7M710, K7M718	0,9	BKR6EK	2288	20	LPG 1
Logan MCV I 1.6 16V	KS	1.6	77	4	08.06-06.13	K4M690, K4M696, K4M697	0,9	BKR6EK	2288	20	LPG 1
Logan MCV I 1.6 16V HiFlex	KS	1.6	77	4	11.09-06.13	K4M694, K4M696	0,9	BKR6EK	2288	20	LPG 1

LOGAN MCV II

Logan MCV II 0.9 TCe 90	K8	0.9	66	3	02.13-	H4B 400	0,7	ILKAR7J7G	91121		
Logan MCV II 1.2 16V	K8	1.2	55	4	02.13-	D4F732, D4F734	0,9	LZKAR7B	5942		
Logan MCV II 1.2 16V LPG	K8	1.2	55	4	02.13-	D4F732, D4F734	0,9	LZKAR7B	5942		

LOGAN PICK-UP

Logan Pick-up 1.4 MPI	US	1.4	55	4	01.09-	K7J 710	0,9	BKR6E	6962	28	LPG 1
-----------------------	----	-----	----	---	--------	---------	-----	-------	------	----	-------





l kW C Y I



Stock-Nº

VLINE

LPG/CNG

DACIA

LOGAN PICK-UP

Logan Pick-up 1.6 LPG	US	1.6	62	4	05.10-	K7M 710	0,9	BKR6EK	2288	20	LPG 1
Logan Pick-up 1.6 MPI	US	1.6	62	4	05.10-	K7M 800	0,9	BKR6EK	2288	20	LPG 1
Logan Pick-up 1.6	US	1.6	64	4	03.08-	K7M710, K7M718	0,9	BKR6EK	2288	20	LPG 1

NOVA

Nova 1.4		1.4	48	4	04.96-03.01	C2J	0,7	BPR6HS	7022	3	BPR7HIX
Nova 1.6		1.6	53	4	04.96-03.03		0,9	BPR5ES	7422	6	LPG 2

SANDERO

Sandero 0.9 TCe	B8M1, B8MA	0.9	66	3	01.13-	H4B400, H4B408	0,7	ILKAR7F7G	90061		
Sandero Stepway 0.9 TCe	B8M1, B8MA	0.9	66	3	01.13-	H4B400, H4B408	0,7	ILKAR7F7G	90061		
Sandero 0.9 TCe LPG	B8M1	0.9	66	3	09.15-	H4B410	0,7	ILKAR7F7G	90061		
Sandero Stepway 0.9 TCe LPG	B8M1	0.9	66	3	09.15-	H4B410	0,7	ILKAR7F7G	90061		
Sandero 1.0 Hi-Flex	BS0R, BS1G	1.0	56	4	01.11-12.12	D4D760	0,9	LZKAR7B	5942		
Sandero 1.2	B8J3, B8MG, B8MP, B8MU, B8MY	1.2	54	4	05.15-	D4F732	0,9	LZKAR7B	5942		
Sandero Stepway 1.6 LPG	BS03	1.6	60	4	01.11-12.12	K7M818	0,9	BKR6EK	2288	20	LPG 1
Sandero 1.6 LPG	BS03	1.6	62	4	05.10-10.12	K7M818	0,9	BKR6EK	2288	20	LPG 1
Sandero 1.6	BS0B, BS0D, BS0F, BS0H	1.6	64	4	12.07-12.12	K7M710	0,8	BKR5EK	7956	23	LPG 1
Sandero 1.6	BS0B, BS0D, BS0F, BS0H	1.6	64	4	12.07-12.12	K7M710	0,9	BKR6EK	2288	20	LPG 1
Sandero 1.6 Hi-Flex	BS1H	1.6	64	4	06.08-12.12	K7M732	0,9	BKR6EK	2288	20	LPG 1
Sandero 1.6 LPG	BS0D	1.6	64	4	06.08-12.12	K7M718	0,9	BKR6EK	2288	20	LPG 1
Sandero Stepway 1.6	BS0B, BS0D, BS0F, BS0H	1.6	64	4	01.09-12.12	K7M710	0,8	BKR5EK	7956	23	LPG 1
Sandero Stepway 1.6	BS0B, BS0D, BS0F, BS0H	1.6	64	4	01.09-12.12	K7M710	0,9	BKR6EK	2288	20	LPG 1
Sandero Stepway 1.6 LPG	BS0D	1.6	64	4	01.10-12.12	K7M718	0,9	BKR6EK	2288	20	LPG 1

SANDERO I

Sandero I 1.2 16V	BS	1.2	55	4	11.08-	D4F 732	0,9	LZKAR7B	5942		
Sandero I 1.2 16V LPG	BS	1.2	55	4	11.08-	D4F 732	0,9	LZKAR7B	5942		
Sandero I 1.4 Mpi	BS	1.4	55	4	06.08-	K7J 710	0,9	BKR6E	6962	28	LPG 1
Sandero I 1.6 Mpi 85	BS	1.6	62	4	05.10-	K7M 800	0,9	BKR6EK	2288	20	LPG 1
Sandero I 1.6 Mpi	BS	1.6	64	4	06.08-	K7M 710	0,9	BKR6E	6962	28	LPG 1
Sandero I 1.6 Hi-Flex	BS1H	1.6	64	4	06.08-12.12	K7M732	0,9	BKR6EK	2288	20	LPG 1
Sandero I 1.6 16V Bifuel	BS	1.6	77	4	01.11-	K4M 696	0,9	BKR6EK	2288	20	LPG 1

SANDERO II

Sandero II 0.9 TCe 90	B8	0.9	66	3	01.13-	H4B 400	0,7	ILKAR7J7G	91121		
Sandero II 1.2 16V LPG	B8	1.2	53	4	01.13-	D4F 734	0,9	LZKAR7B	5942		
Sandero II 1.2 16V	B8	1.2	55	4	01.13-	D4F 732	0,9	LZKAR7B	5942		
Sandero II 1.6	B8	1.6	61	4	11.12-	K7M812	0,9	BKR6EK	2288	20	LPG 1

DAEWOO

ARANOS

Aranos 1.8	AJ	1.8	70	4	07.95-11.97	Y18L	0,9	BPR5ES	7422		LPG 2
Aranos		1.8	70	4	11.94-12.99	SOHC	0,9	BPR5ES	7422	6	LPG 2
Aranos		2.0	81	4	11.94-12.99	SOHC	1,1	BPR5ES-11	4424		LPG 2

CIELO

Cielo		1.5	57	4	08.94-08.97	G15MF SOHC	0,8	BPR6ES	7822	2	LPG 2
Cielo		1.5	74	4	08.94-08.97	A15MF DOHC	1,1	BKR6E-11	2756	14	LPG 1





l kW C
Y
I



Stock-N°

VLINE

LPG/CNG

DAEWOO

ESPERO

Espero	1.5	66	4	.95-10.99	A15MF DOHC 16V	1,1	BKR6E-11	2756	14	LPG 1
Espero	1.8	66	4	02.95-10.99	C18LE	0,8	BPR6ES	7822	2	LPG 2
Espero	2.0	77	4	02.95-10.99	C20LE	0,8	BPR6ES	7822	2	LPG 2

EVANDA

Evanda	2.0	96	4	.03-02.05	T20SED	0,8	BKR5EK	7956	23	LPG 1
--------	-----	----	---	-----------	--------	-----	--------	------	----	-------

KALOS

Kalos 1.2 SE	1.2	53	4	04.03-02.05	B12S1	1,1	BPR5EY-11	3028		LPG 2
Kalos 1.4 SE S100	1.4	61	4	09.02-02.05	F14S3	0,8	BPR6ES	7822	2	LPG 2
Kalos 1.4 SE	1.4	61	4	04.03-02.05	F14S3 SOHC	0,8	BPR6ES	7822	2	LPG 2
Kalos 1.4 SX	1.4	69	4	04.03-02.05	F14D3 DOHC	1,1	BKR6E-11	2756	14	LPG 1

LACETTI

Lacetti	1.4	68	4	09.03-02.05	F14D3	1,1	BKR6E-11	2756	14	LPG 1
Lacetti	1.6	80	4	09.03-02.05	F16D3	1,1	BKR6E-11	2756	14	LPG 1
Lacetti	1.8	90	4	09.03-02.05	T18SED	0,8	BKR5EK	7956	23	LPG 1

LANOS

Lanos	1.4	55	4	05.97-02.05	A14SMS SOHC	0,8	BPR6ES	7822	2	LPG 2
Lanos	1.5	63	4	05.97-02.05	A15SMS SOHC	0,8	BPR6ES	7822	2	LPG 2
Lanos	1.6	78	4	05.97-02.05	A16DMS DOHC	1,1	BKR6E-11	2756	14	LPG 1

LEGANZA

Leganza	2.0	100	4	07.97-12.02	X20SED DOHC	0,8	BKR5EK	7956	23	LPG 1
Leganza	2.2		4	07.97-12.02	T22SED DOHC	0,9	BKR6EK	2288	20	LPG 1

MATIZ

Matiz	0.8	38	3	06.98-02.05	F8CV	1,1	BCPR5EY-11	4120		LPG 3
Matiz	1.0	47	4	03.03-02.05	B10S	1,1	BCPR5EY-11	4120		LPG 3

MUSSO

Musso	2.0	100	4	09.96-	M 161.940	0,8	BCP5ES	7496	16	LPG 3
Musso 16V	2.3	110	4	11.96-	M 161.970	0,8	BCP5ES	7496	16	LPG 3
Musso E32	3.2	162	6	05.96-	Mercedes M162990	0,8	BCP5ES	7496	16	LPG 3

NEW BROUGHAM

New Brougham	2.0	85	4	01.96-02.97	SOHC	1,1	BPR5ES-11	4424		LPG 2
New Brougham	2.0	106	4	01.96-02.97	DOHC 16V	0,8	BKR5EK	7956	23	LPG 1
New Brougham	2.2	110	4	01.96-02.97	DOHC 16V	0,8	BKR5EK	7956	23	LPG 1

NEW PRINCE

New Prince	1.8	81	4	04.96-02.97	SOHC	1,1	BPR5ES-11	4424		LPG 2
New Prince	1.8	101	4	04.96-02.97	DOHC 16V	0,8	BKR5EK	7956	23	LPG 1
New Prince	2.0	85	4	04.96-02.97	SOHC	1,1	BPR5ES-11	4424		LPG 2
New Prince	2.0	106	4	04.96-02.97	DOHC 16V	0,8	BKR5EK	7956	23	LPG 1

NEXIA

Nexia	1.5	55	4	02.95-	OHC	0,8	BPR6ES	7822	2	LPG 2
Nexia	1.5	66	4	02.95-	DOHC 16V	1,1	BKR6E-11	2756	14	LPG 1
Nexia	1.8	74	4	12.95-10.96	C18LE SOHC	0,8	BPR6ES	7822	2	LPG 2

NUBIRA

Nubira	1.6	80	4	07.97-02.05	A16DMS DOHC	1,1	BKR6E-11	2756	14	LPG 1
Nubira 1.8 CDX	1.8	90	4	.03-02.05	T18SED	0,8	BKR5EK	7956	23	LPG 1
Nubira	2.0	99	4	07.97-02.05	X20SED DOHC	0,8	BKR5EK	7956	23	LPG 1





l kW C
Y
I



Stock-N°

VLINE

LPG/CNG

DAEWOO

REZZO

Rezzo / Tacuma U100	1.6	77	4	.01-02.05	A16DMS	1,1	BKR5E-11	6953	33	LPG 1
Rezzo / Tacuma U100	2.0	89	4	.01-02.05	T20SED	0,8	BKR5EK	7956	23	LPG 1

TACUMA

Tacuma	1.6		4	.01-	L4 DOHC	1,1	BKR6E-11	2756	14	LPG 1
Tacuma	1.8		4	.01-	L4 SOHC	0,9	BPR5ES	7422	6	LPG 2
Tacuma	2.0		4	.01-	L4 DOHC	0,8	BKR5EK	7956	23	LPG 1

DAIHATSU

APPLAUSE I

Applause 1.6	A101	1.6	73	4	09.97-05.00	HDE	1,1	BKR6E-11	2756	14	LPG 1
Applause 1.6	A101	1.6	77	4	06.89-08.97	HDE	1,0	BKUR6EK	2213		

CHARADE

Charade G10	1.0	38	3	.81-	CB20	0,8	BPR5EY	2828	9	LPG 2
Charade G11	1.0	38	3	.83-	CB22	0,8	BPR5EY	2828	9	LPG 2
Charade GTti G100	1.0	74	3	03.87-	CB80	0,8	BPR6EKN	1128		
Charade G102	1.3	66	4	07.91-	HC-E	1,1	BKR6E-11	2756	14	LPG 1
Charade G112 4WD	1.3	66	4	02.97-	HC-E	1,1	BKR6E-11	2756	14	LPG 1

COPEN

Copen L880K	0.66	50	4	09.03-	JB-DET	1,1	IFR6J11	7658		
Copen L881	1.3	64	4	10.05-	K3-VE	1,1	BKR6EY-11	4368		LPG 1

CUORE

Cuore L501	0.85	32	3	05.95-04.96	ED20	0,8	BPR6EY	6427		LPG 2
Cuore L501	0.85	32	3	05.96-	ED20	1,1	BPR5EY-11	3028		LPG 2
Cuore L701	1.0	40	3	10.98-09.01	EJ-DE	1,1	BKR5E-11	6953	33	LPG 1
Cuore L701	1.0	43	3	07.01-	EJ-VE	0,9	BKR5EKC	5216		LPG 1
Cuore L251	1.0	43	3	05.03-	EJ-VE	0,9	BKR5EKC	5216		LPG 1
Cuore 1.0 Top L276	1.0	52	3	09.07-	1KR-FE	1,1	ILFR6T11	4904		

FOURTRAK

Fourtrak	2.2		4	.86-	DL52	0,8	BPR5EY	2828	9	LPG 2
----------	-----	--	---	------	------	-----	--------	------	---	-------

GRAN MOVE

Gran Move L901	1.0	40	3	10.99-	EJ-DE	1,0	BKUR6EK	2213			
Gran Move G303	1.5	66	4	04.97-	HE-EG	1,1	BKR6E-11	2756	14	LPG 1	
Gran Move 1.6	G301	1.6	67	4	05.98-09.00	HDEP	1,1	BKR6E-11	2756	14	LPG 1
Gran Move G301	1.6	67	4	07.99-	HD-EP	1,1	BKR6E-11	2756	14	LPG 1	
Gran Move 1.6	G301	1.6	67	4	10.00-09.03	HDEP	1,0	BKUR6EK	2213		
Gran Move 1.6	G301	1.6	77	4	09.97-09.00	HDEP	1,1	BKR6E-11	2756	14	LPG 1
Gran Move 1.6	G301	1.6	77	4	10.00-07.02	HDEP	1,0	BKUR6EK	2213		

HIJET

Hijet	1.0		3	.86-	CB42	0,8	BPR5EY	2828	9	LPG 2
Hijet	1.3	48	4	08.98-	HC-ES	1,0	BKUR6EK	2213		

MATERIA

Materia 1.3	1.3	67	4	12.06-	K3-VE	0,9	IKR7D	4759		
Materia 1.5	1.5	76	4	12.06-	3SZ-VE	0,9	IKR7D	4759		

MIRA

Mira	0.85		3	01.93- .97	ED10 (K)	0,9	BPR6EY	6427		LPG 2
------	------	--	---	------------	----------	-----	--------	------	--	-------





l kW C
Y
I



Stock-N°

VLINE

LPG/CNG

DAIHATSU

MOVE

Move L601	0.85	31	3	.97-10.00	ED20	1,1	BPR5EY-11	3028		LPG 2
Move L901	1.0	40	3	10.99-09.02	EJ-DE	1,0	BKUR6EK	2213		

PYZAR

Pyzar 1.6	G301	1.6	67	4	06.98-08.00	HDEP	1,1	BKR6E-11	2756	14	LPG 1
Pyzar 1.6	G301	1.6	67	4	09.00-07.02	HDEP	1,0	BKUR6EK	2213		

ROCKY

Rocky F80		2.0	65	4	04.84-04.93	3Y	0,8	BP5EY	7327		LPG 2
Rocky F85		2.0	65	4	04.84-04.93	3Y	0,8	BP5EY	7327		LPG 2

SIRION

Sirion (M100)(M110)		1.0	40	3	06.98- .00	EJ-DE	1,0	BKUR6EK	2213		
Sirion (M100)(M110)		1.0	43	3	05.00- .04	EJ-VE	0,9	BKR5EKC	5216		LPG 1
Sirion (M300)		1.0	51	3	01.05-	1KR-FE	1,1	ILFR6T11	4904		
Sirion (M301)		1.3	64	4	01.05-06.07	K3-VE	1,1	BKR6EY-11	4368		LPG 1
Sirion (M301)		1.3	64	4	07.07-	K3-VE	0,9	DCPR7EA-9	6651		
Sirion (M301 / M311)		1.3	67	4	03.08-	K3-VE	0,9	DCPR7EA-9	6651		
Sirion (M101)(M111)		1.3	75	4	09.01- .04	K3-VE2	1,0	BKUR6ETB-10	5742		

TERIOS

Terios 1.3 J100		1.3	61	4	09.97- .00	HC-EJ Alu. Cyl. Head	1,0	BKUR6EK	2213		
Terios 1.3 J102		1.3	63	4	05.00-12.05	K3-VE	1,0	BKUR6ETB-10	5742		
Terios 1.3 J211		1.3		4	.08-	K3-VE	1,1	BKR6EY-11	4368		LPG 1
Terios 1.5 J200 / J210		1.5	75	4	09.10-	3SZ-VE	0,9	DCPR7EA-9	6651		
Terios 1.5 DVVT	J200	1.5	75	4	09.10-	3SZ-VE	0,9	DCPR7EA-9	6651		
Terios 1.5 J200 / J210		1.5	77	4	01.06-12.07	3SZ-VE	0,9	IKR7D	4759		
Terios 1.5 DVVT	J200	1.5	77	4	11.06-12.07	3SZ-VE	0,9	IKR7D	4759		
Terios 1.5 J200 / J210		1.5	77	4	01.08-	3SZ-VE	0,9	DCPR7EA-9	6651		
Terios 1.5 DVVT	J200	1.5	77	4	01.08-	3SZ-VE	0,9	DCPR7EA-9	6651		
Terios 1.5 DVVT LPG	J210	1.5	77	4	06.09-	3SZ-VE	0,9	DCPR7EA-9	6651		

TREVIS

Trevis automatic		1.0	43	4	09.06-	EJ-VE	0,9	BKR6EKC	2848	26	LPG 1
Trevis Schaltgetriebe / gearbox		1.0	43	4	09.06-	EJ-VE	1,0	BKUR6EK	2213		

YRV

YRV (M200)		1.0	43	4	08.00-07.05	EJ-VE	0,9	BKR5EKC	5216		LPG 1
YRV (M201)(M211)		1.3	64	4	01.01-07.05	K3-VE	1,0	BKUR6ETB-10	5742		
YRV (M201)Turbo		1.3	95	4	.02-07.05	K3-VET	0,8	BKR6EP-8	2215		LPG 1

DAIMLER

4.0

4.0 Litre		4.0	164	6	09.89-09.94	AJ6	0,8	BCPR6ES	2330	12	LPG 3
-----------	--	-----	-----	---	-------------	-----	-----	---------	------	----	-------

4.0 SUPER V8

4.0 Super V8		4.0		8	09.97-03.00		1,3	PFR6G-13E	2341		
4.0 Super V8		4.0		8	03.00-03.02		1,1	PFR5G-11E	3000		
4.0 Super V8		4.0		8	03.02-		1,0	IFR5N10	7866		

4.0 V8

4.0 V8		4.0		8	09.97-09.98		1,3	PFR5G-13E	2761		
4.0 V8		4.0		8	09.98-03.00		1,3	PFR5G-13E	2761		
4.0 V8		4.0		8	03.00-03.02		1,1	PFR5G-11E	3000		





kw
C
Y
I



Stock-N°

VLINE

LPG/CNG

DAIMLER

4.0 V8

4.0 V8	4.0		8	03.02-		1,0	IFR5N10	7866		
--------	-----	--	---	--------	--	-----	---------	------	--	--

CENTURY

Century 4.0	4.0	180	6	10.95-09.96	AJ6	0,8	BCPR6ES	2330	12	LPG 3
Century 6.0	6.0		12	10.95-09.96	HE	0,6	BR6EF	3177		

DAIMLER MK II

Daimler V8 4.0 (Chassis No 853936→)	X308	4.0	209	8	07.97-12.02	AJ26	1,0	IFR5N10	7866	
Daimler V8 4.0 Supercharged (Chassis No 878718→)	X308	4.0	267	8	07.97-06.03	AJ27S	1,0	IFR5N10	7866	
Daimler V8 4.0 Supercharged (Chassis No 812256→878717)	X308	4.0	267	8	07.97-06.03	AJ27S	1,3	PFR6G-13E	2341	
Daimler V8 4.0 Supercharged	X308	4.0	276	8	07.97-12.02	AJ27S	1,0	IFR5N10	7866	
Daimler V8 4.0 Supercharged	X308	4.0	276	8	07.97-12.02	AJ27S	1,3	PFR6G-13E	2341	

DOUBLE SIX

Double Six	5.3		12	.90-	V12 HE	0,6	BR7EFS	1094		
Double Six	6.0		12	02.93-09.94	HE	0,6	BR7EFS	1094		
Double Six 6.0	6.0		12	.93-	HE	0,6	BR7EF	3346		
Double six	6.0		12	09.94-09.97	HE	0,6	BR6EF	3177		
Double Six			12	.86-09.91	HE	0,6	BR7EFS	1094		
Double Six			12	10.91- .93	HE	0,6	BR7EF	3346		

LIMOUSINE

DS 420 Limousine	4.2		6	-09.92	XK	0,8	BP5ES	6511	8	LPG 2
------------------	-----	--	---	--------	----	-----	-------	------	---	-------

SIX

Six 4.0	4.0		6	09.94-09.97	AJ6	0,8	BCPR6ES	2330	12	LPG 3
---------	-----	--	---	-------------	-----	-----	---------	------	----	-------

SOVEREIGN

Sovereign 4.0	4.0			.89-		0,8	BCPR6ES	2330	12	LPG 3
---------------	-----	--	--	------	--	-----	---------	------	----	-------

V8

4.0 Super V8	4.0	267	8	09.97-03.00	V8	1,3	PFR6G-13E	2341		
4.0 V8	4.0		8	09.97-09.98	AJ26	1,3	PFR5G-13E	2761		
4.0 V8	4.0		8	09.98-03.00	AJ26	1,3	PFR5G-13E	2761		
4.0 Super V8	4.0		8	03.00-03.02	AJ26	1,1	PFR5G-11E	3000		
4.0 V8	4.0		8	03.00-03.02	AJ26	1,1	PFR5G-11E	3000		
4.2 Super V8	4.2		8	03.02-	AJ26	1,0	IFR5N10	7866		
4.2 V8	4.2		8	03.02-	AJ26	1,0	IFR5N10	7866		

DODGE

AVENGER

Avenger	2.0	115	6	06.07-		1,1	PZFR5F-11	4363		LPG 6
Avenger	2.0		4	.95- .99	L4 MPI Y DOHC	1,1	BKR6EIX-11	3764		LPG 1
Avenger	2.5		6	.95-	V6 MPI N DOHC	1,1	PFR5G-11	2647		
Avenger	2.7	138	6	06.07-	V6	1,3	LZTR5A-13	4612		

CALIBER

Caliber 1.8	1.8	110	4	.06-		1,1	ZFR5F-11	2262	40	LPG6
Caliber 2.0	2.0	115	4	.06-		1,1	ZFR5F-11	2262	40	LPG6
Caliber 2.4	2.4	125	4	.06-		1,1	ZFR5F-11	2262	40	LPG6

CHALLENGER

DODGE Challenger 5.7 Coupe	5.7	277	8	01.09-	EZH	1,1	LZFR5CI-11	92145		
DODGE Challenger 5.7 Coupe	5.7	280	8	01.10-	EZC	1,1	LZFR5CI-11	92145		





l kW C
Y
I



Stock-N°

VLINE

LPG/CNG

DODGE

CHARGER

DODGE Charger 5.7	5.7	250	8	01.09-12.10	EZA	1,1	LZFR5CI-11	92145		
DODGE Charger 5.7	5.7	257	8	01.09-12.09	EZA	1,1	LZFR5CI-11	92145		
DODGE Charger 5.7	5.7	276	8	09.11-	EZH	1,1	LZFR5CI-11	92145		
Charger SRT8 (Twin Spark)	6.1		8	.06-	W V8 FI	1,3	PLZTR5A-13	4998		

COLT

Colt	1.5		4	.93- .94	L4 MPI A	1,1	BPR5EIX-11	2115		LPG 2
Colt	1.8		4	.92- .94	L4 MPI C	1,1	BKR5EIX-11	5464		LPG 1
Colt	2.4		4	.92- .92	L4 MPI W	1,1	BPR5EIX-11	2115		LPG 2
Colt	2.4		4	.93- .94	L4 MPI G	1,1	BKR6EIX-11	3764		LPG 1

DURANGO

DODGE Durango 5.7 (HB)	5.7	257	8	01.09-12.10	EZA	1,1	LZFR5CI-11	92145		
DODGE Durango 5.7 (WD)	5.7	268	8	01.11-	EZH	1,1	LZFR5CI-11	92145		

INTREPID

Intrepid	2.7		6	.98-	V6 MPI R DOHC	1,3	LZTR5A-13	4612		
Intrepid	3.3		6	.93- .97	V6 MPI T	1,2	GR45	4268		GR5IX
Intrepid	3.3		6	.94- .95	V6 FF U	1,2	GR45	4268		GR5IX
Intrepid	3.5		6	.93- .97	V6 MPI F	0,9	FR5-1	7252		

JOURNEY

Journey 2.4 VVT	JC	2.4	125	4	07.09-12.12	ED3	1,1	ZFR5F-11	2262	40	LPG6
-----------------	----	-----	-----	---	-------------	-----	-----	----------	------	----	------

MAGNUM

Magnum SRT8		6.1		8	.06-	W V8 FI	1,3	PLZTR5A-13	4998		
-------------	--	-----	--	---	------	---------	-----	------------	------	--	--

NEON

Neon		2.0		4	.95- .99	L4 MPI Y DOHC	0,8	BKR6ES	3783	28	LPG 1
Neon		2.0		4	.02-	L4 MPI C SOHC	0,8	BKR6ES	3783	28	LPG 1

NITRO

Nitro 4.0 V6	KJ (UE86)	4.0	191	6	09.06-12.07	EGS	1,3	ZFR5LP-13G	7781		
--------------	-----------	-----	-----	---	-------------	-----	-----	------------	------	--	--

R1500-3500

R1500-3500		3.9		6	.94- .96	MPI X	0,9	FR4	5155		
R1500-3500		3.9		6	.97- .99	MPI X	1,1	FR5-1	7252		
R1500-3500		5.2		8	.94- .96	MPI Y	0,9	FR4	5155		
R1500-3500		5.2		8	.95- .96	CNG T	0,9	FR4	5155		
R1500-3500		5.2		8	.97- .99	CNG T, MPI Y	1,1	FR5-1	7252		
R1500-3500		5.9		8	.94- .97	MPI Z	0,9	FR4	5155		
R1500-3500		5.9		8	.94- .95	TBI 5	1,1	WR5	2438		
R1500-3500		5.9		8	.97- .97	MPI 5	0,9	FR4	5155		
R1500-3500		5.9		8	.98- .99	MPI 5, MPI Z	1,1	FR5-1	7252		
R1500-3500		8.0		10	.94- .96	MPI W	1,1	PZFR5F-11	4363		LPG 6
R1500-3500		8.0		10	.97- .99	MPI W	1,1	PZFR5F-11	4363		LPG 6

RAM

DODGE RAM 1500	DJ, DS	5.7	257	8	01.09-	EZH	1,1	LZFR5CI-11	92145		
DODGE RAM 2500 (D1, DC, DH, DM, DR)		5.7	257	8	01.09-12.09	EZA	1,1	LZFR5CI-11	92145		
DODGE RAM 2500 (DJ, DS)		5.7	287	8	01.09-		1,1	LZFR5CI-11	92145		
DODGE RAM 1500		5.7	291	8	01.09-12.10	EZD, EZE, EZH	1,1	LZFR5CI-11	92145		

STEALTH

Stealth		3.0		6	.91- .92	V6 MPI B DOHC	1,1	PFR6J-11	2743		
---------	--	-----	--	---	----------	---------------	-----	----------	------	--	--





l kW C
Y I



Stock-N°

VLINE

LPG/CNG

DODGE

STEALTH

Stealth Turbo	3.0		6	.91- .92	V6 MPI C DOHC	1,1	PFR6J-11	2743		
Stealth	3.0		6	.93- .96	V6 MPI H SOHC	1,1	BPR5EIX-11	2115		LPG 2
Stealth	3.0		6	.93- .96	V6 MPI J DOHC	1,1	PFR6J-11	2743		
Stealth Turbo	3.0		6	.93- .96	V6 MPI K DOHC	1,1	PFR6J-11	2743		

STRATUS

Stratus	2.0		4	.95-	L4 MPI C SOHC	0,9	FR5	7373		
Stratus	2.4		4	.95- .00	L4 MPI X DOHC	1,1	FR45	3686		
Stratus	2.4		4	.01- .03	L4 FI X,G DOHC, TURBO	1,3	LZTR5A-13	4612		
Stratus	2.4		4	.04-	L4 FI X,G	1,1	LZTR4A-11	5444		
Stratus	2.5		6	.95-	V6 MPI H DOHC	1,1	PFR5G-11	2647		

VIPER

Viper	8.0		10	.92- .02	E V10 MPI	0,9	FR5-1	7252		
Viper	8.3		10	.03- .03	Z V10	0,8	ZFR5N	7917		
Viper	8.3		10	.04- .06	Z V10	1,1	PZFR6F-11	3271		LPG 6

FERRARI

458

458 4.5	4.5	419	8	12.09-	F136FB	0,8	MR8AP8HJS	93340		
458 4.5	4.5	445	8	09.13-	F136FL	0,8	MR8AP8HJS	93340		

458 SPIDER

458 Spider 4.5	4.5	419	8	09.11-	F136FB	0,8	MR8AP8HJS	93340		
458 Spider 4.5	4.5	445	8	12.14-	F136FL	0,8	MR8AP8HJS	93340		

575 M

575 M Maranello / F1	5.7	379	12	02.02-06.06	F133E	0,7	DCPR9EIX	2316		
----------------------	-----	-----	----	-------------	-------	-----	----------	------	--	--

599

599 GTB FIORANO	6.0	456	12	05.06-	F140C	0,7	PMR8B	6378		
-----------------	-----	-----	----	--------	-------	-----	-------	------	--	--

612

612 Scaglietti	5.7	397	12	09.04-	F133F	0,7	DCPR9EIX	2316		
----------------	-----	-----	----	--------	-------	-----	----------	------	--	--

CHALLENGE

Challenge Stradale	3.6	313	8	01.04-	F131B	0,7	PMR8B	6378		
--------------------	-----	-----	---	--------	-------	-----	-------	------	--	--

ENZO

Enzo	6.0	485	12	.02-	F140B	0,7	PMR8B	6378		
------	-----	-----	----	------	-------	-----	-------	------	--	--

F12 BERLINETTA

F12 Berlinetta 6.3	6.3	544	12	10.12-	F140FC	0,8	MR8AP8HJS	93340		
--------------------	-----	-----	----	--------	--------	-----	-----------	-------	--	--

F348

F348 TB; TS	3.4	221	8	09.89-04.94	F119D040 Cat.	0,6	DR8EIX	6681		
348 GTB; GTS	3.4	221	8	04.90-03.93	F119F	0,7	DCPR9EIX	2316		
348 GTB; GTS	3.4	236	8	03.93-06.94	F119H	0,7	DCPR9EIX	2316		
F348 GTB; GTS / Spider	3.9	221	8	07.94-07.95	F119	0,7	DCPR9EIX	2316		

F355

F355	3.5	280	8	05.94-01.96	F129C	0,7	PMR8A	5851		
F355GTS	3.5	280	8	05.94-01.96	F129B	0,7	PMR8A	5851		
F355 Berlinetta	3.5	280	8	07.94-		0,6	CR8EIX	4218		
F355 GTS	3.5	280	8	07.94-		0,6	CR8EIX	4218		
F355 Spider	3.5	280	8	07.95-		0,7	PMR7A	4259		





l kW C
Y
I



Stock-N°

VLINE

LPG/CNG

FERRARI

F355

F355GTS	3.5	280	8	02.96-	F129C	0,7	PMR7A	4259		
F355 F1 berlinetta; GTS; Spider	3.5	280	8	11.97-	F129C	0,7	PMR7A	4259		

F360

Modena 360 - 360 F1	3.6	294	8	05.99-11.03	F131B	0,7	PMR8A	5851		
360 Spider / F1	3.6	294	8	09.00-11.03	F131B	0,7	PMR8A	5851		
360 Spider / F1	3.6	294	8	12.03-	F131B	0,7	PMR8B	6378		

F40

F40	2.9	353	8	01.88-05.92	F120A	0,5	C8E	7471		
-----	-----	-----	---	-------------	-------	-----	-----	------	--	--

F430

F430 Coupe / F430 Spider / F430 Challenge	4.3	360	8	01.05-	F136E	0,7	PMR8B	6378		
430 Scuderia	4.3	375	8	.08-	F136ED	0,7	PMR8B	6378		

F456

F456 GT	5.5	324	12	02.96-04.98	F116C	0,7	DCPR9EIX	2316		
F456 GTA	5.5	324	12	07.96-04.98	F116C.010	0,7	DCPR9EIX	2316		
456 M GTA	5.5	325	12	05.98-	F116C.010	0,7	DCPR9EIX	2316		
465 M GT	5.5	325	12	05.98-	F116C	0,7	DCPR9EIX	2316		

F50

F50	4.7	361	12	05.95-	F130B	0,7	PMR7A	4259		
-----	-----	-----	----	--------	-------	-----	-------	------	--	--

F512

512 TR	5.0	316	12	02.91-10.96	F113D	0,7	DCPR9EIX	2316		
--------	-----	-----	----	-------------	-------	-----	----------	------	--	--

FF

FF 6.3	6.3	478	12	06.11-	F140EB	0,8	MR8AP8HJS	93340		
FF 6.3	6.3	485	12	06.11-	F140EB	0,8	MR8AP8HJS	93340		

MONDIAL

Mondial T/ T Cabriolet	3.4	221	8	11.88-02.94	F119DL Cat	0,6	DR8EIX	6681		
------------------------	-----	-----	---	-------------	------------	-----	--------	------	--	--

TESTAROSSA

Testarossa	4.9	272	12	10.84-10.91	F113B000 Cat.	0,6	DR8EIX	6681		
------------	-----	-----	----	-------------	---------------	-----	--------	------	--	--

F456

F456 GT	5.5	324	12	04.93-01.96	F116B	0,7	DCPR9EIX	2316		
---------	-----	-----	----	-------------	-------	-----	----------	------	--	--

F550

F550 Maranello	5.5	357	12	08.96-	F133A	0,7	DCPR9EIX	2316		
----------------	-----	-----	----	--------	-------	-----	----------	------	--	--

FIAT

126

126 (650cc)	0.65	22		01.83-06.96	141A.000	0,8	BPR6ES	7822	2	LPG 2
126 BIS	0.7	19	2	09.87-06.91	126A2.000	0,8	BPR6ES	7822	2	LPG 2

500

500 0.9 TwinAir	312	0.9	59	2	12.13-	312A5.000	0,8	ILKR9G8	97168		
500 0.9 TwinAir	312	0.9	77	2	12.13-	199B6.000	0,8	ILKR9G8	97168		
500 1.0 TwinAir	312	1.0	44	2	12.13-	312A6.000	1,2	LKR7DI-12	90779		
500X 1.4 MultiAir	334	1.4	100	4	09.14-		0,8	IKR9J8	93311		
500 1.4	312	1.4	103	4	09.09-	312A3.000	0,8	IKR9J8	93311		
500X 1.4 MultiAir	334	1.4	103	4	09.14-		0,8	IKR9J8	93311		
500X 1.4 MultiAir	334	1.4	120	4	02.15-		0,8	IKR9J8	93311		
500X 1.4 MultiAir	334	1.4	125	4	02.15-		0,8	IKR9J8	93311		





l kW C
Y
I



Stock-N°

VLINE

LPG/CNG

FIAT

500

500C	312	1.4	132	4	09.09-01.13	312A3.000	0,8	IKR9J8	93311		
500 1.4	312	1.4	140	4	08.08-	312A9.000	0,8	IKR9J8	93311		
500 1.6	334AXE1A	1.6	81	4	11.14-		1,0	ZKR7BI-10	95536		

500 C

500C 0.9 TwinAir	312	0.9	59	2	12.13-	312A5.000	0,8	ILKR9G8	97168		
500C 0.9	312	0.9	63	2	09.10-	312A2.000	0,8	ILKR9G8	97168		
500C 1.0 TwinAir	312	1.0	44	2	01.14-	312A6.000	1,2	LKR7DI-12	90779		
500C 1.0	312	1.0	48	2	09.12-	312A4.000	1,2	LKR7DI-12	90779		
500C 1.2	312	1.2	51	4	06.09-	169A4.000	1,0	ZKR7A-10	1691	42	LPG 8
500C 1.4	312	1.4	74	4	06.09-	169A3.000	1,0	DCPR7E-N-10	4983	43	
500C 1.4	312	1.4	99	4	01.11-	312A1.000	0,8	IKR9J8	93311		
500C 1.4	312	1.4	103	4	09.09-	312A3.000	0,8	IKR9J8	93311		
500C 1.4	312	1.4	118	4	05.11-	312A1.000, 312A3.000	0,8	IKR9J8	93311		
500C 1.4 Abarth 695	312	1.4	132	4	02.13-	312A3.000	0,8	IKR9J8	93311		

500 L

500L 1.4	199LYB1B	1.4	70	4	09.12-	843A1.000	1,0	DCPR7E-N-10	4983	43	
500 L 0.9 Natural Power TwinAir	199	0.9	63	2	03.13-	312A2.000 CNG	0,8	ILKR9G8	97168		
500 L 0.9 TwinAir	199	0.9	77	2	09.12-	199B6.000	0,8	ILKR9G8	97168		
500 L 1.4	199	1.4	70	4	09.12-	843A1.000	0,9	DCPR7E-N-10	4983	43	
500 L 1.4 T-Jet	199	1.4	88	4	10.13-	940B7.000	0,8	IKR9J8	93311		

500 MY07

500 0.9 Natural Power TwinAir	312	0.9	63	2	07.10-	312A2.000 CNG	0,8	ILKR9G8	97168		
500 0.9 TwinAir	312	0.9	77	2	10.13-	199B6.000	0,8	ILKR9G8	97168		
500 1.0	312	1.0	48	2	09.12-	312A4.000	1,2	LKR7DI-12	90779		
500C 1.0	312	1.0	48	2	09.12-	312A4.000	1,2	LKR7DI-12	90779		
500 1.2	312	1.2	51	4	07.07-	169A4.000	1,0	ZKR7A-10	1691	42	LPG 8
500 1.2 LPG (Euro 5; Italy)	312	1.2	51	4	01.09-	169A4.000	0,8	ZKR7AI-8	92402		
500 1.4 16V	312	1.4	74	4	07.07-	169A3.000	1,0	DCPR7E-N-10	4983	43	
500 1.4 Abarth	312	1.4	99	4	08.08-	312A1.000	0,8	IKR9J8	93311		
500 1.4 T-Jet (Abarth)	312	1.4	102	4	05.08-	198A1.000	0,8	IKR9J8	93311		
500 1.4 Abarth	312	1.4	132	4	08.08-	312A3.000	0,8	IKR9J8	93311		
500 1.4 Abarth	312	1.4	140	4	08.08-	312A1.000	0,8	IKR9J8	93311		

600

600 (Chassis No →2543171)	187	1.1	40	4	06.05-01.10	187A1.000	0,9	BKR6EKC	2848	24	
600 (Chassis No 2543171→)	187	1.1	40	4	06.05-01.10	187A1.000	1,0	DCPR7E-N-10	4983	43	
600 1.1 (Chassis No 2543172→)	187AX-C1A02	1.1	40	4	06.05-01.10	187A1.000	1,0	DCPR7E-N-10	4983	43	

ALBEA / SIENA

Albea / Siena 1.2	178	1.2	44	4	09.01-12.12	178C4.066	0,9	BKR5EZ	7642	36	LPG 1
Albea / Siena 1.2 Engine no. → 2533528	178	1.2	44	4	09.01-12.12	188A4.000	0,9	BKR6EKC	2848	36	LPG 1
Albea / Siena 1.2 Engine no. 2533529 →	178	1.2	44	4	09.01-12.12	188A4.000	1,0	DCPR7E-N-10	4983	43	
Albea / Siena 1.2	178	1.2	54	4	09.98-12.02	178B5.000	0,9	BKR6EKC	2848	26	LPG 1
Albea / Siena 1.2	178	1.2	59	4	09.01-12.11	188A5.000	1,0	DCPR7E-N-10	4983	43	
Sienna 1.2	178CYE1AAT	1.2	59	4	09.01-12.11	188A5.000	1,0	DCPR7E-N-10	4983	43	
Albea 1.2	178BYE1AAT, 178CYE1AAT	1.2	59	4	01.02-12.11	188A5.000	1,0	DCPR7E-N-10	4983	43	



e kW C
Y I

Stock-N°

VLINE

LPG/CNG

FIAT**ALBEA / SIENA**

Albea / Siena 1.4	178	1.4	51	4	04.96-12.02	178B2.000, 178B2.016	0,9	BKR5EZ	7642	36	LPG 1
Albea / Siena 1.4	178	1.4	57	4	10.05-12.12	199A1.000, 834A1.000	0,9	BKR5EZ	7642	36	LPG 1
Albea / Siena 1.6	178	1.6	76	4	11.00-12.12	182B6.000	0,9	BKR5EZ	7642	36	LPG 1
Albea / Siena 1.6	178	1.6	78	4	07.97-06.99	178B3.000	0,9	BKR6EKC	2848	26	LPG 1
Albea / Siena 1.6	178	1.6	78	4	07.99-12.04	178B3.000	0,9	BKR5EZ	7642	36	LPG 1

BARCETTA

Barchetta 1.8	183	1.8	96	4	04.95-07.00	183A1.000	0,9	BKR6EKC	2848	26	LPG 1
Barchetta 1.8 (Chassis No →1945438)	183SA, 183SB1AA	1.8	96	4	01.95-06.05	188A6.000	0,9	BKR6EKC	2848	26	
Barchetta 1.8 (Chassis No 1945438 →)	183SA, 183SB1AA	1.8	96	4	01.95-06.05	188A6.000	0,9	BKR6EZ	4619	38	
Barchetta 1.8	183	1.8	96	4	08.00-05.05	183A1.000	0,9	BKR6EZ	4619	38	LPG 1

BRAVA

Brava i.,80 16V Sx,Hsx	182	1.2	59	4	03.98-05.99	182B2.000	0,9	DCPR8EKC	7168		LPG 8
Brava 80 16V; Trofeo,Steel Sx,Hsx	182	1.2	59	4	06.99-05.01	182B2.000	0,9	DCPR8E-N	5692		LPG 8
Brava 1.2	182	1.2	59	4	09.00-05.02	188A5.000	0,9	DCPR8E-N	5692		
Brava i.	182	1.4	55	4	10.95-02.98	182A5.000	0,9	BKR6EKC	2848	26	LPG 1
Brava S,SX	182	1.4	59	4	10.95-05.01	182A3.000	0,9	BKR6EKC	2848	26	LPG 1
Brava 16V	182	1.6	66	4	10.95-05.01	182A6.000	0,9	BKR6EKC	2848	26	LPG 1
Brava i. 16V EL; aut. EL; ELX	182	1.6	76	4	10.95-06.96	182A4.000	0,9	BKR6EKC	2848	26	LPG 1
Brava 1.6 (not for Northern Europe)	182BB	1.6	76	4	02.96-10.01	182A4.000	0,9	BKR5EZ	7642	36	LPG 1
Brava i.,100 16V;Aut. Sx,Hsx,Elx	182	1.6	76	4	05.98-06.99	182A4.000	0,9	BKR6EKC	2848	26	LPG 1
Brava 100 16V Sx,Hsx,Elx;Aut. (Northern Europe)	182	1.6	76	4	07.99-05.01	182A4.000	0,9	BKR5EZ	7642	36	LPG 1
Brava 1.6 (Northern Europe)	182	1.6	76	4	09.00-05.02	182B6.000	0,9	BKR5EZ	7642	36	LPG 1
Brava 1.6	182	1.6	76	4	09.00-05.02	182B6.000	0,9	BKR6EKC	2848	26	
Brava 1.6 (not for Northern Europe)	182BU1AA	1.6	76	4	09.00-05.02	182B6.000	0,9	BKR5EZ	7642	36	LPG 1
Brava 16V Aut.	182	1.8	83	4	10.95-05.01	182A2.000	0,9	BKR6EKC	2848	26	LPG 1

BRAVO

Bravo i.,80 16V Sx;Trofeo;Steel	182	1.2	59	4	09.98-07.99	182B2.000	0,9	DCPR8E-N	5692		LPG 8
Bravo 80 16V Sx Trofeo; Steel	182	1.2	59	4	08.99-08.00	182B2.000	0,9	DCPR8EKC	7168		LPG 8
Bravo i.	182	1.4	55	4	10.95-02.97	182A5.000	0,9	BKR6EKC	2848	26	LPG 1
Bravo 1.4i S	182	1.4	59	4	03.98-05.01	182A3.000	0,9	BKR6EKC	2848	26	LPG 1
Bravo i. 16V	182	1.6	66	4	10.95-05.01	182A6.000	0,9	BKR5EZ	7642	36	LPG 1
Bravo i., 100 16V EL;Aut.	182	1.6	76	4	10.95-06.01	182A4.000	0,9	BKR6EKC	2848	26	LPG 1
Bravo 1.6 iE	182AB	1.6	76	4	03.96-10.01	182A4.000	0,9	BKR5EZ	7642	36	LPG 1
Bravo i.100 16V El,Sx,GT,Steel; Aut. (Northern Europe)	182	1.6	76	4	07.99-05.01	182A4.000	0,9	BKR6EKC	2848	26	LPG 1
Bravo 1.6 iE	182AU1AA	1.6	76	4	09.00-08.03	182B6.000	0,9	BKR5EZ	7642	36	LPG 1
Bravo 1.8L - 16V GT	182	1.8	83	4	03.95-05.01	182A2.000	0,9	BKR6EKC	2848	26	LPG 1
Bravo i. 20V, 155 HGT	182	2.0	108	5	10.95-05.01	182A1.000	0,9	BKR6EKC	2848	26	LPG 1
Bravo 2.0	182	2.0	113	5	09.98-08.00	182B7.000	0,9	BKR6EKC	2848	26	LPG 1
Bravo 155 20V	182	2.0	113	4	12.99-05.01	182A1.000	0,9	BKR6EKC	2848	26	LPG 1

BRAVO MY07

Bravo 1.4 16V	198	1.4	66	4	04.07-12.14	192B2.000	1,0	DCPR7E-N-10	4983	43	
Bravo 1.4 T-Jet	198	1.4	88	4	09.07-12.14	198A4.000	0,8	IKR9J8	93311		
Bravo 1.4 MultiAir	198	1.4	103	4	05.10-12.14	198A7.000	0,8	IKR9J8	93311		
Bravo 1.4 T-Jet	198	1.4	110	4	04.07-12.14	198A1.000	0,8	IKR9J8	93311		





l kW C
Y
I



Stock-N°

VLINE

LPG/CNG

FIAT

CINQUECENTO

Cinquecento iE (700cc)	170AD	0.7	22	2	07.91-01.98	170A.046	0,9	BPR6ES	7822	2	LPG 2
Cinquecento (700cc)	170	0.7	23	2	07.91-02.97	170A.000	0,9	BPR6ES	7822	2	LPG 2
Cinquecento (700cc)	170	0.7	23	2	12.91-01.96	171A.000	0,9	BPR6ES	7822	2	LPG 2
Cinquecento 0.9 iE	170CF	0.9	29	4	07.91-02.98	1170A1.046	0,8	BPR6ES	7822		LPG 2
Cinquecento iE (900cc)	170	0.9	29	4	02.95-05.98	1170A1.046	0,9	BPR6ES	7822	2	LPG 2
Cinquecento (900cc)	170	0.9	29	4	04.96-05.98		0,9	BPR6ES	7822	2	LPG 2
Cinquecento (900cc)	170	0.9	30	4	.92-05.98	170A1.046 Cat	0,9	BPR6ES	7822	2	LPG 2
Cinquecento iE (900cc)	170	0.9	30	4	.92-05.98	170A1.000	0,9	BPR6ES	7822	2	LPG 2
Cinquecento iE	170	1.1	40	4	10.94-05.98	176B2.000	0,9	BCPR6ES	2330	12	LPG 3
Cinquecento Sporting Fire	170	1.1	40	4	.94-05.98	176A6.000	0,9	BCPR6ES	2330	12	LPG 3

COUPE

Coupe 1.8L 16V Eng. Number → 1070427	FA, 175	1.8	96	4	02.96-02.01	183A1.000	0,9	BKR6EKC	2848	26	LPG 1
Coupe 1.8L 16V 1070427→ Eng. Number	FA, 175	1.8	96	4	06.98-08.00	183A1.000	0,9	BKR6EZ	4619	38	
Coupe 1.8 -/iE (Engine 1070427→)	175AXA1A	1.8	96	4	06.98-08.00	183A1.000	0,9	BKR6EZ	4619	38	LPG 1
Coupe 2.0	FA, 175	2.0	96	5	03.96-08.00	182B3.000	0,9	BKR6EKC	2848	26	
Coupe 2.0 iE	FA, 175	2.0	102	4	02.94-08.96	836A3.011	0,8	B7ES	1111		BR8EIX
Coupe 2.0L 16V	FA, 175	2.0	103	4	02.94-09.96	836A3.000	0,8	BPR7ES	2023	19	BPR8EIX
Coupe 2.0L 20 V	FA, 175	2.0	108	5	12.96-02.01	182A1.000	0,9	BKR6EKC	2848	26	LPG 1
Coupe 2.0 iE	175AXC1A	2.0	113	5	04.98-08.00	182B3.000	0,9	BKR6EKC	2848	26	LPG 1
Coupe 2.0L 16V Turbo	FA, 175	2.0	140	4	02.94-09.96	175A1.000	0,8	BUR6ET	3172	1	LPG 2
Coupe 2.0L 20V Turbo	FA, 175	2.0	162	5	10.96-02.01	175A3.000	0,8	BKUR6ET	6437	27	LPG 1
Coupe 2.0L 20V Turbo	FA, 175	2.0	162	5	-12.96	175A3.000	0,9	BKR6EKC	2848	26	LPG 1

CROMA

Croma 2.0L	154	2.0	66	4	.86- .91	154C2.000	0,8	BPR7ES	2023	19	BPR8EIX
Croma CHT- 2.0L	154	2.0	72	4	.91-02.97	154C5.000	0,8	BPR7ES	2023	19	BPR8EIX
Croma 2.0L	154	2.0	84	4	.86-02.97	834B146	0,8	BPR7ES	2023	19	BPR8EIX
Croma 2.0L	154	2.0	85	4	07.91-02.97	154C3.046 Cat	0,8	BPR7ES	2023	19	BPR8EIX
Croma 2.0L	154	2.0	86	4	.91-02.97	154C3.000	0,8	BPR7ES	2023	19	BPR8EIX
Croma 2.0L	154	2.0	89	4	.86- .91	154C.000	0,8	BPR7ES	2023	19	BPR8EIX
Croma 16V- 2.0L	154	2.0	101	4	.91-02.97	154E1.000	0,8	BPR7ES	2023	19	BPR8EIX
Croma 2.0 Ti Turbo	154	2.0	110	4	.86-02.97	834C146	0,8	BP6ET	1263		LPG 2
Croma Ti Turbo	154	2.0	110	4	.86-02.97	154C4.000	0,8	BP6ET	1263		LPG 2
Croma Turbo	154	2.0	110	4	.91-02.97	154C4.046 Cat	0,8	BP6ET	1263		LPG 2
Croma 2.0 Turbo	154	2.0	114	4	.86-02.97	154A2.000	0,8	BP6ET	1263		LPG 2
Croma V6- 2.5L	154	2.5	117	6	.93-02.97	834G.000	0,8	BPR7ES	2023	19	BPR8EIX

CROMA MY05

Croma 1.8 16V	194	1.8	103	4	06.05-12.11	939A4.000	0,8	ZFR5F	5165	53	LPG 6
Croma 2.2 16V	194	2.2	108	4	06.05-12.13	194A1.000	1,0	LTR6B-10T	5948		

DOBLO

Doblo Cargo 1.4	263YXA1A, 263HXA1A	1.4	70	4	02.10-	843A1.000	1,0	DCPR7E-N-10	4983	43	
Doblo Cargo 1.6 Natural Power	223WXD1A	1.6	68	4	02.04-07.09	182B6 000 CNG	0,9	BKR6EKC	2848	26	LPG 1
Doblo 1.6 Natural Power	223AXD1A	1.6	68	4	11.05-07.09	182B6 000 CNG	0,9	BKR6EKC	2848	26	LPG 1

DOBLO (119)

Doblò 1.2		1.2	48	4	11.00-12.04	223A5.000	0,9	BKR5EZ	7642	36	LPG 1
Doblò 1.2		1.2	48	4	12.04-02.05	223A5.000	1,0	DCPR7E-N-10	4983	43	





e kW C
Y
I



Stock-N°

VLINE

LPG/CNG

FIAT

DOBLO (119)

Doblò 1.4	1.4	56	4	09.05-08.13	350A1.000	1,0	ZKR7A-10	1691	42	LPG 8
Doblò 1.6	1.6	76	4	11.00-06.05	182B6.000	0,9	BKR5EZ	7642	36	LPG 1
Doblò 1.6 Natural Power Active	1.6	76	4	11.00-07.09	182B6 000 CNG	0,9	BKR6EKC	2848	26	

DOBLO (152)

Doblò 1.4	1.4	70	4	02.10-	843A1.000	1,0	DCPR7E-N-10	4983	43	
Doblò 1.4 T-Jet Natural Power	1.4	88	4	02.10-	198A4.000 CNG	0,8	IKR9J8	93311		
Doblò 1.4 T-Jet	1.4	88	4	10.11-	198A4.000	0,8	IKR9J8	93311		

DUCATO

Ducato 2.0	2.0	55	4	01.86-01.94	170B(XN1T), 170D(XN1TA)	0,9	BP6ES	7811	4	LPG 2	
Ducato 10	2.0	62	4	06.88-	XN1TA	0,9	BP6ES	7811	4	LPG 2	
Ducato 2.0	290	2.0	62	4	06.90-05.94	170D_	0,9	BP6ES	7811	4	LPG 2
Ducato 15 2.0 LPG	244BTMFRAX	2.0	71	4	11.02-07.06	RFL	0,9	BKR6EKC	2848	26	LPG 1
Ducato 2.0	230	2.0	74	4	06.94-12.95	R5B	0,9	BKR6EKC	2848	4	LPG 1
Ducato 14 2.0	230	2.0	80	4	03.94-09.01	RFW	0,9	BKR6EKC	2848	26	LPG 1
Ducato 2.0	230	2.0	80	4	06.94-09.01	RFW	0,9	BKR6EKC	2848	4	LPG 1
Ducato 10 2.0	230	2.0	80	4	06.94-09.01	RFW	0,9	BKR6EKC	2848	26	LPG 1
Ducato 14 2.0	230	2.0	80	4	06.94-09.01	RFW	0,9	BKR6EKC	2848	26	LPG 1
Ducato 18 2.0	230	2.0	80	4	06.94-09.01	RFW	0,9	BKR6EKC	2848	26	LPG 1
Ducato 10 2.0	230	2.0	80	4	11.94-09.01	RFW	0,9	BKR6EKC	2848	26	LPG 1
Ducato 14 2.0	230	2.0	80	4	11.94-09.01	RFW	0,9	BKR6EKC	2848	26	LPG 1
Ducato 2.0	244	2.0	81	4	12.01-07.06	RFL	0,9	BKR6EKC	2848	4	LPG 1
Ducato 11 2.0	244APMFAAX, 244APMPA06, 244APMRA08, 244ATMFAAX, 244ATMFBAX, 244ATMNBA	2.0	81	4	12.01-07.06	RFL	0,9	BKR6EKC	2848	26	LPG 1
Ducato 15 2.0	244APMPA06, 244APMRA08, 244BPMACAX, 244BPMFAAX, 244BPMFBAX, 244BTMRB10, 244BTMSBAX, 244BTWFBAX	2.0	81	4	12.01-07.06	RFL	0,9	BKR6EKC	2848	26	LPG 1
Ducato 15 2.0	244BPWNBAX, 244BTWFAAX, 244BTWNBAX	2.0	81	4	05.02-07.06	RFL	0,9	BKR6EKC	2848	26	LPG 1
Ducato 18 2.0	244CTWNBAX	2.0	81	4	05.02-07.06	RFL	0,9	BKR6EKC	2848	26	LPG 1

EGEA

Egea 1.4	356	1.4	70	4	10.15-	843A1.000	1,0	DCPR7E-N-10	4983	43
Egea 1.4	356SXA1B	1.4	70	4	10.15-	843A1.000	1,0	DCPR7E-N-10	4983	43
Egea 1.4	356HXA1B	1.4	70	4	07.16-	843A1.000	1,0	DCPR7E-N-10	4983	43
Egea 1.6	356WXE11	1.6	81	4	07.16-		1,0	ZKR7BI-10	95536	

FIORINO

Fiorino 1.3 Pick Up	146RA	1.3	49	4	10.93-12.94	146A5.000	0,9	BPR6ES	7822	2	LPG 2
Fiorino 1.4 Pick Up	146RE	1.4	49	4	05.94-05.01	146D5.000	0,9	BKR6E	6962	28	LPG 1
Fiorino 1.4	159AC	1.4	51	4	01.93-07.96	160A1.046	0,9	BPR5ES	7422	6	LPG 2
Fiorino 1.4 iE	146RB	1.4	52	4	10.93-10.96	146C5.000	0,9	BPR6ES	7822	2	LPG 2
Fiorino 1.4 Pick Up	146RB	1.4	52	4	10.93-10.96	146C5.000	0,9	BPR6ES	7822	2	LPG 2
Fiorino 1.4	225BXA1A, 225BXF1A	1.4	54	4	11.07-	KFT, KFV	0,9	BKR6EKC	2848	26	LPG 1





l kW C
Y
I



Stock-N°

VLINE

LPG/CNG

FIAT

FIORINO

Fiorino 1.4	225BXA1A, 225BXF1A	1.4	54	4	02.08-	KFT, KFV	0,9	BKR6EKC	2848	26	LPG 1
Fiorino 1.4	225BXA1A, 225AXA1A	1.4	57	4	07.14-	350A1.000	1,0	ZKR7A-10	1691	42	LPG 8
Fiorino 1.5	159AC	1.5	55	4	01.90-08.93	149C1.000 Cat	0,9	BPR6ES	7822	2	LPG 2
Fiorino 1.6 iE	146RC, 146RF	1.6	55	4	10.93-05.01	146D6.000	0,9	BCPR7ES	3330		BCPR7EIX
Fiorino 1.6 iE	146RC, 146RF	1.6	55	4	10.93-05.01	146D6.000	0,8	BCPR7ES	3330		BCPR7EIX
Fiorino 1.6 Pick Up	146RC, 146RF	1.6	55	4	01.94-05.01	146C6.000	0,8	BPR7ES	2023		
Fiorino Pick Up 1.6	146RC, 146RF	1.6	55	4	01.94-05.01	146D6.000	0,8	BCPR7ES	3330		BCPR7EIX
Fiorino Pick Up 1.6	146RC, 146RF	1.6	55	4	01.94-05.01	146C6.000	0,8	BPR7ES	2023		BPR8EIX

FIORINO 225

Fiorino 1.4	225	1.4	54	4	02.08-	KFT	0,9	BKR6EZ	4619	38	LPG 1
Fiorino 1.4 Natural Power	225	1.4	57	4	10.09-	350A1.000 CNG	1,0	ZKR7A-10	1691	42	

FREEMONT

Freemont 2.4 VVT	345	2.4	125	4	08.11-	B	1,1	ZFR5F-11	2262	40	LPG6
------------------	-----	-----	-----	---	--------	---	-----	----------	------	----	------

GRANDE PUNTO

Grande Punto 1.2	199	1.2	48	4	09.05-06.13	199A4.000	1,0	ZKR7A-10	1691	42	LPG 8
Grande Punto 1.2 LPG	199AXA1A, 199BXA1A	1.2	51	4	06.08-12.12	199A4.000	1,0	ZKR7A-10	1691	42	LPG 8
Grande Punto 1.2	199	1.2	51	4	09.10-05.12	169A4.000	1,0	ZKR7A-10	1691	42	
Grande Punto 1.4	199	1.4	55	4	06.06-07.07	199A7.000	1,0	ZKR7A-10	1691	42	LPG 8
Grande Punto 1.4	199	1.4	57	4	09.05-06.13	350A1.000	1,0	ZKR7A-10	1691	42	LPG 8
Grande Punto Van 1.4	199CXB1A, 199DXB1A	1.4	57	4	02.06-06.13	350A1.000	1,0	ZKR7A-10	1691	42	LPG 8
Grande Punto 1.4 NATURAL POWER	199	1.4	57	4	09.08-12.12	350A1.000	1,0	ZKR7A-10	1691	42	
Grande Punto 1.4 16V	199	1.4	70	4	09.05-08.11	199A6.000	1,0	ZKR7A-10	1691	42	LPG 8
Grande Punto 1.4 T-Jet	199	1.4	88	4	06.07-08.10	198A4.000	0,8	IKR9J8	93311		
Grande Punto 1.4 Abarth	199	1.4	114	4	12.07-12.12	199A8.000	0,8	IKR9J8	93311		
Grande Punto 1.4 Abarth	199	1.4	132	4	04.09-12.12	199A8.000	0,8	IKR9J8	93311		

IDEA

Idea 1.2 16V	350	1.2	59	4	12.03-12.10	188A5.000	1,0	DCPR7E-N-10	4983	43	
Idea 1.4 LPG	350AXF1A	1.4	57	4	10.04-12.12	350A1.000	1,0	ZKR7A-10	1691	42	LPG 8
Idea 1.4	350	1.4	57	4	09.05-12.12	350A1.000	1,0	ZKR7A-10	1691	42	LPG 8
Idea 1.4	350	1.4	66	4	12.03-12.10	192B2.000	1,0	DCPR7E-N-10	4983	43	
Idea 1.4	350AXE1A	1.4	66	4	12.03-12.10	192B2.000	1,0	DCPR7E-N-10	4983	43	
Idea 1.4	350	1.4	70	4	10.03-12.12	843A1.000	1,0	DCPR7E-N-10	4983	43	

LINEA

Linea 1.4	323	1.4	57	4	06.07-	350A1.000	1,0	ZKR7A-10	1691	42	LPG 8
Linea 1.4 T-Jet	323	1.4	88	4	09.07-	198A4.000	0,8	IKR9J8	93311		

MAREA

Marea 1.6	185AXH1A	1.6	68	4	03.99-08.00	185A3.000	0,9	BKR5EZ	7642	36	LPG 1
Marea 1.6	185AXH1A	1.6	68	4	03.99-08.00	185A3.000	0,9	BKR6EKC	2848	26	LPG 1
Marea 1.6	185	1.6	72	4	09.00-08.02	182B5.098	0,9	BKR6EKC	2848	26	
Marea 1.6	185AXL1A	1.6	72	4	09.00-08.02	182B5.098	0,9	BKR5EZ	7642	36	LPG 1
Marea 1.6	185	1.6	75	4	04.97-02.99	185A3.000	0,9	BKR6EKC	2848	26	
Marea 1.6	185AXH	1.6	75	4	04.97-02.99	185A3.000	0,9	BKR5EZ	7642	36	LPG 1





l kW C
Y I



Stock-N°

VLINE

LPG/CNG

FIAT

MAREA

Marea 1.6	185AXH	1.6	75	4	04.97-02.99	185A3.000	0,9	BKR6EKC	2848	26	LPG 1
Marea 1.6	185AXB, 185AXB11, 185AXB1A	1.6	76	4	08.96-08.00	182A4.000	0,9	BKR5EZ	7642	36	LPG 1
Marea S.W./Weekend 1.6	185BXB, 185BXB11, 185BXB1A	1.6	76	4	08.96-08.00	182A4.000	0,9	BKR5EZ	7642	36	LPG 1
Marea 1.6 BiPower	185AXB11, 185AXB1A	1.6	76	4	03.99-05.02	182A4.000	0,9	BKR5EZ	7642	36	LPG 1
Marea 1.6 S.W./Weekend	185	1.6	76	4	09.00-08.02	182B6.000	0,9	BKR6EKC	2848	26	
Marea 1.8	185AXC, 185AXC1A	1.8	83	4	08.99-08.00	182A2.000	0,9	BKR6EZ	4619	38	LPG 1
Marea S.W./Weekend 1.8	185BXC, 185BXC1A	1.8	83	4	08.99-08.00	182A2.000	0,9	BKR6EZ	4619	38	LPG 1
Marea 2.0	185	2.0	110	5	09.00-06.06	185A8.000	0,9	BKR6EKC	2848	26	
Marea 2.0	185	2.0	113	5	03.99-08.00	182B7.000	0,9	BKR6EKC	2848	26	

MAREA / MARENGO

Marea 1.2 i.;80 16V, Weekend	185	1.2	59	4	03.98-05.99	182B2.000	0,9	DCPR8EKC	7168		LPG 8
Marea 1.2 80 16V Sx,Hsx; Weekend	185	1.2	60	4	12.98-12.00	182B2.000	0,9	DCPR8E-N	5692		LPG 8
Marea 1.6 i. 16V; Weekend	185	1.6	76	4	09.96-04.98	182A4.000	0,9	BKR6EKC	2848	26	LPG 1
Marea 1.6 i. 16V Sx Bipower	185	1.6	76	4	11.97-12.03	182A4.000	0,9	BKR6EKC	2848	26	
Marea 1.6 16V Sx,Elx,Aut., Weekend	185	1.6	76	4	05.98-11.98	182A4.000	0,9	BKR5EZ	7642	36	LPG 1
Marea 1.6 16V,Sx,Elx,Aut., Weekend	185	1.6	76	4	12.98-12.03	182A4.000	0,9	BKR5EZ	7642	36	LPG 1
Marea 1.8 i. 16 V, Weekend	185	1.8	83	4	09.96-11.98	182A2.000	0,9	BKR6EKC	2848	26	LPG 1
Marea 1.8 16V; Weekend	185	1.8	83	4	12.99-08.00	182A2.000	0,9	BKR6EKC	2848	26	LPG 1
Marea 2.0 20V	185	2.0	108	5	09.96-02.99	182A1.000	0,9	BKR6EKC	2848	26	LPG 1

MULTIPLA

Multipla 1.6	186AXC1A	1.6	68	4	05.04-08.05	182B6.000	0,9	BKR5EZ	7642	36	LPG 1
Multipla 1.6 16V Natural Power	186	1.6	70	4	01.99-12.04	186A3.000 CNG	0,9	BKR6EKC	2848	26	
Multipla 1.6	186AGB1A	1.6	70	4	04.02-06.10	182B6.000	0,9	BKR5EZ	7642	36	LPG 1
Multipla 1.6 16V Bipower	186	1.6	76	4	01.99-12.04	186A4.000	0,9	BKR6EKC	2848	26	
Multipla 1.6	186AXA1A	1.6	76	4	04.99-08.00	182A4.000	0,9	BKR6EKC	2848	26	
Multipla 1.6 16V Sx	186	1.6	76	4	07.99-12.04	186A4.000	0,9	BKR5EZ	7642	36	LPG 1
Multipla 1.6	186AXC1A	1.6	76	4	09.00-06.10	182B6.000	0,9	BKR5EZ	7642	36	LPG 1
Multipla Van 1.6	186BMC1A, 186BXC1A	1.6	76	4	10.01-06.10	182B6.000	0,9	BKR5EZ	7642	36	LPG 1
Multipla 1.6 16V	186	1.6	76	4	09.04-06.10	182B6.000	0,9	BKR5EZ	7642	36	LPG 1
Multipla 1.6 Natural Power	186AG- B1A05	1.6	77	4	11.08-06.10	182B6 000 CNG	0,9	BKR6EKC	2848	26	LPG 1

PALIO

Palio 1.0	178	1.0	45	4	06.96-10.03	178A1.000	0,9	BKR6E	6962	28	LPG 1
Palio 1.1	178	1.1	40	4	06.96-10.03	178B9.033	0,9	BKR6EKC	2848	26	
Palio 1.2 8V	178	1.2	44	4	07.97-10.04	188A4.000	0,9	BKR5EZ	7642	36	LPG 1
Palio 1.2	178	1.2	44	4	07.97-08.02	178B7.045	0,9	BKR6EKC	2848	26	
Palio 1.2 Weekend	178	1.2	44	4	07.97-10.04	178C4.066, 188A4.000	0,9	BKR6EKC	2848	26	
Palio Weekend 1.2	178BXZ1A	1.2	50	4	06.99-10.02	178E2.000	0,9	BKR6EKC	2848	26	LPG 1
Palio 1.2 65	178	1.2	50	4	01.00-12.00	178E2.000	0,9	BKR6EKC	2848	26	LPG 1
Palio 1.2 75 Weekend	178	1.2	54	4	11.97-02.01	178B5.000	0,9	BKR6EKC	2848	26	LPG 1
Palio 1.2	171414	1.2	59	4	03.00-01.12	178D6.011	1,0	DCPR7E-N-10	4983	43	
Palio 1.2 16V	178	1.2	59	4	09.01-11.02	188A5.000	0,9	DCPR8E-N	5692		LPG 8





l kW C
Y
I



Stock-N°

VLINE

LPG/CNG

FIAT

PALIO

Palio Weekend 1.2	178DYE1A, 178DYE1AAP, 178DYE1AAT	1.2	59	4	09.01-10.04	178D6.011, 188A5.000	1,0	DCPR7E-N-10	4983	43	
Palio 1.2 16V	178	1.2	59	4	12.02-01.12	188A5.000	1,0	DCPR7E-N-10	4983	43	
Palio 1.4	178BXC1A	1.4	51	4	06.96-08.99	178B2.000	0,9	BKR5EKC	5216		LPG 1
Palio Weekend 1.4	178DXC1A	1.4	51	4	07.97-08.01	178B2.000	0,9	BKR5EKC	5216		LPG 1
Palio 1.4	178	1.4	51	4	09.97-08.01	178B2.000	0,9	BKR5EZ	7642	36	LPG 1
Palio 1.4	178	1.4	57	4	04.05-01.12	199A1.000	0,9	BKR6EKC	2848	23	LPG 1
Palio 1.4	178	1.4	63	4	10.02-10.04	350A1.000	1,0	ZKR7A-10	1691	42	
Palio 1.5	178	1.5	62	4	02.02-01.12	178E5.022	0,9	BKR6ES	3783	28	LPG 1
Palio Weekend 1.6	178DXD1A, 178DXD1AAP, 178DXD1AAT	1.6	74	4	06.96-02.01	178B3.000	0,9	BKR5EZ	7642	36	LPG 1
Palio 1.6 16V	178	1.6	74	4	.96-06.99	182B6.000	0,9	BKR6EKC	2848	26	LPG 1
Palio 1.6 16V Weekend	178	1.6	76	4	11.97-06.99	178B3.000	0,9	BKR6EKC	2848	26	LPG 1
Palio 1.6 16V Weekend	178	1.6	76	4	07.99-10.02	178B3.000	0,9	BKR5EZ	7642	36	LPG 1

PANDA

Panda 750 CLX -CL-L- Fire	141	0.75	24	4	01.86-12.96	156A_	0,9	BCPR6ES	2330	12	LPG 3
Panda 0.75 Young	141	0.75	25	4	01.86-12.96	141B.000	0,9	BPR6ES	7822	2	LPG 2
Panda 900- Jolly-Van	141	0.9	29	4	01.97-01.01	1170A1.046	0,9	BKR5EZ	7642	36	LPG 1
Panda 900	141	0.9	29	4	-12.96	1170A1.046	0,9	BPR6ES	7822	2	LPG 2
Panda 0.9 Natural Power TwinAir	312PXN1A	0.9	51	2	03.19-		0,8	ILKR9G8	97168		
Panda 0.9 TwinAir	312	0.9	59	2	12.13-	312A5.000	0,8	ILKR9G8	97168		
Panda 0.9 Natural Power TwinAir	312	0.9	59	2	01.15-	312A5.000 CNG	0,8	ILKR9G8	97168		
Panda 0.9 TwinAir	312	0.9	66	2	06.14-	312A7.000	0,8	ILKR9G8	97168		
Panda 1.0	141	1.0	32	4	01.86-04.96	156A2.048-156A2.146, 156A2.246	0,9	BCPR6ES	2330	12	LPG 3
Panda 1.0	141	1.0	33	4	01.86-12.96	156A2.246	0,9	BCPR6ES	2330	12	LPG 3
Panda 1.0 young-L- CLX	141	1.0	33	4	06.94-12.96	141C2.000	0,9	BPR6ES	7822	2	LPG 2
Panda Van 1.0	141	1.0	33	4	01.97-	141C2.000	0,9	BKR6EKC	2848	26	LPG 1
Panda 1.0 TwinAir	312	1.0	44	2	12.13-	312A6.000	1,2	LKR7DI-12	90779		
Panda 1.1 Selecta	141	1.1	37	4	07.90-12.96	156C.046 Cat	0,9	BCPR6ES	2330	12	LPG 3
Panda 1.1	141	1.1	40	4	02.95-12.96	176B2.000	0,9	BCPR6ES	2330	12	LPG 3
Panda 1.1 4x4	141	1.1	40	4	02.95-12.96	176B2.000	0,9	BCPR6ES	2330	12	LPG 3
Panda 1.1 4X4	141	1.1	40	4	01.96-08.00	156C.046	0,9	BCPR6ES	2330	12	LPG 3
Panda Van 1.1 Selecta	141	1.1	40	4	01.97-08.00	176B2.000	0,9	BKR6EKC	2848	26	LPG 1
Panda 1.1	141	1.1	40	4	09.00-	187A1.000	0,9	BKR5EZ	7642	36	LPG 1
Panda Van 1.1 (Engine-No. ->2533528)	169CXA1A	1.1	40	4	03.04-12.12	187A1.000	0,9	BKR5EZ	7642	36	LPG 1
Panda Van 1.1 (Engine No. 2533529->)	169CXA1A	1.1	40	4	03.04-12.12	187A1.000	1,0	DCPR7E-N-10	4983	43	
Panda Van 1.2 (Engine No. 2533529->)	169CXB1A	1.2	44	4	03.04-12.12	188A4.000	1,0	DCPR7E-N-10	4983	43	
Panda Van 1.2 (Engine No. 2533529->)	169CXB2A	1.2	44	4	09.04-12.12	188A4.000	1,0	DCPR7E-N-10	4983	43	
Panda 1.2	169AXF2A	1.2	51	4	04.10-12.12	169A4.000	1,0	ZKR7A-10	1691	42	LPG 8
Panda Van 1.2	169CXF2A, 169CXF1A	1.2	51	4	09.10-12.12	169A4.000	1,0	ZKR7A-10	1691	42	LPG 8
Panda Van 1.2 LPG	169CXF1A	1.2	51	4	09.10-12.12	169A4.000	0,8	ZKR7AI-8	92402		
Panda Classic 1.2	169AXF1A	1.2	51	4	01.12-08.13	169A4.000	1,0	ZKR7A-10	1691	42	LPG 8
Panda Van 1.2	312PXA1A	1.2	51	4	01.13-	169A4.000	1,0	ZKR7A-10	1691	42	LPG 8





l kW C
Y
I



Stock-Nº

VLINE

LPG/CNG

FIAT

PANDA MY03

Panda 1.1	169	1.1	40	4	09.03-12.04	187A1.000	0,9	BKR5EZ	7642	36	LPG 1
Panda 1.1	169	1.1	40	4	12.04-12.12	187A1.000	1,0	DCPR7E-N-10	4983	43	
Panda 1.2 (Engine No→2533528)	169	1.2	44	4	10.04-12.12	188A4.000	0,9	BKR5EZ	7642	36	LPG 1
Panda 1.2 (Engine No 2533529→)	169	1.2	44	4	10.04-12.12	188A4.000	1,0	DCPR7E-N-10	4983	43	
Panda 1.2	169	1.2	51	4	03.10-12.12	169A4.000	1,0	ZKR7A-10	1691	42	LPG 8
Panda 1.2 EasyPower LPG (Euro 5)	169	1.2	51	4	11.10-	169A4.000	0,8	ZKR7AI-8	92402		
Panda 1.4 Natural Power	169	1.4	57	4	01.10-12.12	350A1.000 CNG	1,0	ZKR7A-10	1691	42	
Panda 1.4 16V ABARTH	169	1.4	74	4	06.07-12.11	169A3.000	1,0	DCPR7E-N-10	4983	43	

PANDA MY12

Panda 0.9	312	0.9	63	2	01.12-	312A2.000	0,8	ILKR9G8	97168		
Panda 0.9 Natural Power	312	0.9	63	2	07.12-	312A2.000 CNG	0,8	ILKR9G8	97168		
Panda 1.0	312	1.0	48	2	01.12-	312A4.000	1,2	LKR7DI-12	90779		
Panda 1.2	312	1.2	51	4	01.12-	169A4.000	1,0	ZKR7A-10	1691	42	LPG 8

PUNTO

Punto Van 1.1	176	1.1	40	4	06.97-06.00	176B2.000	0,9	BCPR6ES	2330	12	LPG 3
Punto 1.1 60 Cabrio S	176	1.2	40	4	06.97-06.98	176B2.000	0,9	BCPR6ES	2330	12	LPG 3
Punto Van 1.2	188CXA1A, 188DXA1A	1.2	44	4	02.00-10.09	188A4.000	1,0	DCPR7E-N-10	4983	43	
Punto 1.2 TwinAir (Euro 4)	199AYL1A, 199BYL1A	1.2	49	4	02.14-	199B9.000	1,0	ZKR7A-10	1691	42	LPG 8
Punto Evo Van 1.4	199AXB1A	1.4	57	4	03.09-02.12	350A1.000	1,0	ZKR7A-10	1691	42	LPG 8
Punto Van 1.4 (Euro 4)	199AXB1A, 199AXL1A	1.4	57	4	03.12-	350A1.000	1,0	ZKR7A-10	1691	42	LPG 8
Punto 1.4 LPG (Euro 5)	199AXB1A, 199BXB1A	1.4	57	4	03.12-	350A1.000	0,8	ZKR7AI-8	92402		
Punto Van 1.4 (Euro 5)	199AXB1A, 199AXL1A	1.4	57	4	03.12-	350A1.000	0,8	ZKR7AI-8	92402		
Punto Evo 1.4 MultiAir	199AXV1B, 199BXV1B	1.4	77	4	10.09-02.12	955A6.000	1,0	DCPR7E-N-10	4983	43	
Punto 1.4 MultiAir	199AXV1B, 199BXV1B	1.4	77	4	03.12-	955A6.000	1,0	DCPR7E-N-10	4983	43	
Punto 1.8 (Chassis No 1945439→)	188AX, 188AXF1A, 188BX, 188BXF1A	1.8	96	4	09.99-10.05	183A1.000, 188A6.000	0,9	BKR6EZ	4619	38	LPG 1

PUNTO 1

Punto 1 1.1	176	1.1	40	4	11.93-05.97	176A6.000	0,9	BCPR6ES	2330	12	LPG 3
Punto 1 1.1 S	176	1.1	40	4	06.94-05.97	176A6.000	0,9	BCPR6ES	2330	12	LPG 3
Punto 1 1.1 S; Sx; 6 Speed	176	1.1	40	4	06.97-09.99	176B2.000	0,9	BCPR6ES	2330	12	LPG 3
Punto 1 1.2	176	1.2	43	4	06.94-05.98	176A7.000	0,9	BCPR6ES	2330	12	LPG 3
Punto 1 1.2	176	1.2	44	4	11.93-05.97	176B1.000	0,9	BCPR6ES	2330	12	LPG 3
Punto 1 1.2	176	1.2	44	4	06.97-09.99	176B4.000	0,9	BCPR6ES	2330	12	LPG 3
Punto 1 1.2 Cabrio	176	1.2	44	4	06.98-02.01	176B4.000	0,9	BCPR6ES	2330	12	LPG 3
Punto 1 1.2	176	1.2	54	4	11.93-05.98	176A8.000	0,9	BCPR6ES	2330	12	LPG 3
Punto 1 1.2 16V	176	1.2	63	4	05.97-09.01	176B9.000	0,9	DCPR8E	4339		LPG 8
Punto 1.2 16V Cabrio	176	1.2	63	4	06.97-06.01	176B9.000	0,9	DCPR8E	4339		LPG 8
Punto 1 1.4 GT Turbo	176	1.4	96	4	06.93-09.99	176B.000, 176A4.000	0,9	BCPR6ET	2197		LPG 3
Punto 1 1.6	176	1.6	65	4	01.94-05.97	176A9.000	0,9	BCPR7ES	3330		BCPR7EIX
Punto 1 1.6 Cabrio ELX	176	1.6	65	4	06.94-05.98	176A9.000	0,9	BCPR7ES	3330		BCPR7EIX
Punto 1 1.6 Sporting	176	1.6	65	4	07.95-05.97	176A9.000	0,9	BCPR7ES	3330		BCPR7EIX





l kW C
Y
I



Stock-N°

VLINE

LPG/CNG

FIAT

PUNTO 2

Punto 2 1.2	188	1.2	44	4	09.00-10.04	188A4.000	0,9	BKR5EZ	7642	36	LPG 1
Punto 2 1.2 Natural Power	188	1.2	44	4	01.04-10.04	188A4.000	0,9	BKR5EZ	7642	36	
Punto 2 1.2 Classic	188	1.2	44	4	10.04-03.12	188A4.000	1,0	DCPR7E-N-10	4983	43	
Punto 2 1.2 Natural Power	188	1.2	44	4	02.05-10.11	188A4.000	1,0	DCPR7E-N-10	4983	43	
Punto 2 1.2 16V	188	1.2	59	4	09.00-11.02	188A5.000	0,9	DCPR8E-N	5692		LPG 8
Punto 2 1.2 16V	188	1.2	59	4	12.02-04.06	188A5.000	1,0	DCPR7E-N-10	4983	43	
Punto 2 1.4 16V	188	1.4	70	4	06.03-10.05	843A1.000	1,0	DCPR7E-N-10	4983	43	
Punto 2 1.8	188	1.8	96	4	09.00-08.02	183A1.000, 188A6.000	0,9	BKR6EKC	2848	26	LPG 1
Punto 2 1.8	188	1.8	96	4	09.02-10.05	183A1.000, 188A6.000	0,9	BKR6EZ	4619	38	LPG 1

PUNTO 3

Punto 3 0.9	199	0.9	63	2	03.12-	312A2.000	0,8	ILKR9G8	97168		
Punto 3 0.9 TwinAir	199	0.9	74	2	12.13-	199B7.000	0,8	ILKR9G8	97168		
Punto 3 0.9 TwinAir	199	0.9	77	2	07.13-	199B6.000	0,8	ILKR9G8	97168		
Punto 3 1.2 TwinAir	199	1.2	49	4	02.14-	199B9.000	0,8	ZKR7AI-8	92402		
Punto 3 1.2	199	1.2	51	4	03.12-	169A4.000	1,0	ZKR7A-10	1691	42	LPG 8
Punto 3 1.4 (Euro 4)	199	1.4	55	4	03.12-	199A7.000	1,0	ZKR7A-10	1691	42	LPG 8
Punto 3 1.4 (Euro 5)	199	1.4	55	4	03.12-	199A7.000	0,8	ZKR7AI-8	92402		
Punto 3 1.4 (Euro 4)	199	1.4	57	4	03.12-	350A1.000	1,0	ZKR7A-10	1691	42	LPG 8
Punto 3 1.4 Natural Power	199	1.4	57	4	03.12-	350A1.000	1,0	ZKR7A-10	1691	42	
Punto 3 1.4 (Euro 5)	199	1.4	57	4	03.12-	350A1.000	0,8	ZKR7AI-8	92402		
Punto 3 1.4 MultiAir	199	1.4	77	4	03.12-	955A6.000	1,0	DCPR7E-N-10	4983	43	
Punto 3 1.4 Turbo MultiAir	199	1.4	99	4	03.12-	955A2.000	0,8	IKR9J8	93311		

PUNTO EVO

Punto EVO 1.2	199	1.2	48	4	09.09-02.12	199A4.000	1,0	ZKR7A-10	1691	42	LPG 8
Punto EVO 1.2	199	1.2	51	4	10.09-02.12	169A4.000	1,0	ZKR7A-10	1691	42	LPG 8
Punto EVO 1.4	199	1.4	55	4	07.09-02.12	199A7.000	1,0	ZKR7A-10	1691	42	LPG 8
Punto EVO 1.4	199	1.4	57	4	09.09-02.12	350A1.000	1,0	ZKR7A-10	1691	42	LPG 8
Punto EVO 1.4 Natural Power	199	1.4	57	4	09.09-02.12	350A1.000 CNG	1,0	ZKR7A-10	1691	42	
Punto EVO 1.4 MultiAir	199	1.4	77	4	09.09-02.12	955A6.000	1,0	DCPR7E-N-10	4983	43	
Punto EVO 1.4 Turbo MultiAir	199	1.4	99	4	09.09-02.12	955A2.000	0,8	IKR9J8	93311		
Punto EVO 1.4 Abarth	199	1.4	120	4	10.09-02.12	955A8.000	0,8	IKR9J8	93311		
Punto EVO 1.4 Abarth	199	1.4	132	4	07.08-02.12	955A8.000	0,8	IKR9J8	93311		

QUBO

Qubo 1.4	225	1.4	54	4	09.08-	KFT, KFV	0,9	BKR6EZ	4619	38	LPG 1
Qubo 1.4	225AXA1A	1.4	54	4	09.08-	KFT, KFV	0,9	BKR6EKC	2848	26	LPG 1
Qubo 1.4 Natural Power	225	1.4	57	4	10.09-	350A1.000	1,0	ZKR7A-10	1691	42	
Qubo 1.4	225AXA1A, 225CXA1A	1.4	57	4	10.09-	350A1.000	1,0	ZKR7A-10	1691	42	LPG 8

SCUDO

Scudo 1.6	220YG5	1.6	58	4	01.96-08.00	220A2.000	0,8	BCPR7ES	3330		BCPR7EIX
Scudo 2.0	220	2.0	100	4	09.99-10.06	RFN	0,9	LF5B	7113	46	LPG 7

SEDICI

Sedici 1.6 VVT (Not for Russia)	189	1.6	79	4	06.06-	M16A	1,1	IFR6J11	7658		
---------------------------------	-----	-----	----	---	--------	------	-----	---------	------	--	--

SEICENTO

Seicento 900 iE	187	0.9	29	4	03.98-12.08	1170A1.046	0,9	BPR6ES	7822	2	LPG 2
-----------------	-----	-----	----	---	-------------	------------	-----	--------	------	---	-------





l kW C
Y I



Stock-N°

VLINE

LPG/CNG

FIAT

SEICENTO

Seicento 1.1 -/iE (Chassis No 2543172→)	187AXB1A, 187AX- C1A02	1.1	40	4	01.98-01.10	187A1.000	1,0	DCPR7E-N-10	4983	43	
Seicento 1.1 iE	187	1.1	40	4	03.98-01.10	176B2.000	0,9	BCPR6ES	2330	12	LPG 3
Seicento 1.1 iE	187	1.1	40	4	10.00-10.04	187A1.000	0,9	BKR5EZ	7642	36	LPG 1
Seicento 1.1 iE	187	1.1	40	4	10.04-01.10	187A1.000	1,0	DCPR7E-N-10	4983	43	

SIENA

Siena 1.4	178CXC1AAE, 178CXC1AAP, 178CXC1AAT	1.4	51	4	06.96-12.02	178B2.000	0,9	BKR5EKC	5216		LPG 1
Siena 1.6	178CXD1AAE, 178CXD1AAP, 178CXD1AAT	1.6	74	4	07.97-12.04	178B3.000	0,9	BKR5EZ	7642	36	LPG 1

STILO

Stilo 1.2 16V	192	1.2	59	4	09.01-10.03	188A5.000	0,9	DCPR8E-N	5692		LPG 8
Stilo 1.2 16V	192	1.2	59	4	12.02-06.04	188A5.000	1,0	DCPR7E-N-10	4983	43	
Stilo 1.4	192	1.4	66	4	09.03-11.06	192B2.000	1,0	DCPR7E-N-10	4983	43	
Stilo 1.4	192AXN1B, 192BXN1B	1.4	66	4	09.03-11.06	192B2.000	1,0	DCPR7E-N-10	4983	43	
Stilo 1.4 16V / SW	192	1.4	70	4	01.04-02.05	843A1.000	1,0	DCPR7E-N-10	4983	43	
Stilo Van 1.4	192DXH1B	1.4	70	4	01.04-08.08	843A1.000	1,0	DCPR7E-N-10	4983	43	
Stilo 1.4 16V /SW	192	1.4	70	4	02.05-08.08	843A1.000	1,0	DCPR7E-N-10	4983	43	
Stilo 1.6	192	1.6	76	4	09.01-05.06	182B6.000	0,9	BKR5EZ	7642	36	LPG 1
Stilo 1.6	192	1.6	77	4	05.05-11.06	192B3.000	1,1	ZFR5F-11	2262	40	LPG6
Stilo 1.6	192AXB1A, 192BxB1A	1.6	100	4	04.05-11.06	182B6.000	0,9	BKR5EZ	7642	36	LPG 1
Stilo Van 1.6	192DXB1A	1.6	100	4	04.05-08.08	182B6.000	0,9	BKR5EZ	7642	36	LPG 1
Stilo 1.8 16V	192	1.8	96	4	09.01-08.08	192A4.000	0,9	BKR6EZ	4619	38	LPG 1
Stilo 1.8 SW	192	1.8	98	4	09.02-08.08	192A4.000	0,9	BKR6EZ	4619	38	LPG 1
Stilo 2.4 20V Abarth	192	2.4	125	5	09.01-04.07	192A2.000	0,9	BKR6EZ	4619	38	LPG 1

STRADA

Strada 1.2	178	1.2	48	4	10.04-	178B7.045	1,0	DCPR7E-N-10	4983	43	
Strada 1.2	178	1.2	54	4	05.99-05.01	178B5.000	0,9	BKR5EZ	7642	36	LPG 1
Strada 1.2	178	1.2		4	01.99-10.05	188A4.000	0,9	BKR5EZ	7642	36	LPG 1
Strada 1.6	178	1.6		4	10.99-10.04	178D2.011	0,9	BKR5EZ	7642	36	LPG 1

TALENTO

Talento 2.0	290UA4, 290UEH4	2.0	55	4	09.89-04.94	170B_	0,9	BP6ES	7811	4	LPG 2
-------------	--------------------	-----	----	---	-------------	-------	-----	-------	------	---	-------

TEMPRA

Tempra 1.4 S.W	159	1.4	51	4	10.94-10.96	836A4.000	0,9	BPR6ES	7822	2	LPG 2
Tempra 1.4	159	1.4	56	4	03.90-10.96	159A2.000	0,9	BPR6ES	7822	2	LPG 2
Tempra 1.4 SW	159	1.4	62	4	04.91-06.93	160A1.046	0,9	BPR6ES	7822	2	LPG 2
Tempra 1.6	159AS, 159AT	1.6	51	4	04.90-07.96	159A3.048	0,8	BPR7ES	2023		BPR8EIX
Tempra S.W./Weekend 1.6	159AS	1.6	51	4	07.93-07.96	159A3.048	0,8	BPR7ES	2023		BPR8EIX
Tempra 1.6	159	1.6	55	4	02.90-12.94	159A3.048	0,8	BPR7ES	2023	19	BPR8EIX
Tempra 1.6	159AE	1.6	55	4	06.92-08.96	835C1.000	0,8	BCPR7ES	3330		BCPR7EIX
Tempra S.W./Weekend 1.6	159AE	1.6	55	4	10.92-10.96	835C1.000	0,8	BCPR7ES	3330		BCPR7EIX
Tempra 1.6	159	1.6	55	4	09.94-10.96	835C1.000	0,9	BCPR7ES	3330		BCPR7EIX
Tempra 1.6	159	1.6	57	4	06.90-07.92	159A3.046	0,8	BPR7ES	2023		
Tempra S.W./Weekend 1.6	159AE	1.6	57	4	04.91-07.96	835C1.000	0,8	BCPR7ES	3330		BCPR7EIX





l kW C
Y
I



Stock-N°

VLINE

LPG/CNG

FIAT

TEMPRA

Tempra 1.6	159	1.6	63	4	03.90-08.96	159A3.000	0,8	B7ES	1111		BR8EIX
Tempra 1.6	159	1.6	63	4	03.90-08.96	159B9.000	0,9	BCPR7ES	3330		BCPR7EIX
Tempra S.W./Weekend 1.6	159AJ	1.6	66	4	07.93-07.96	159B9.000	0,8	BCPR7ES	3330		BCPR7EIX
Tempra 1.6	159AJ	1.6	66	4	06.94-07.96	159B9.000	0,8	BCPR7ES	3330		BCPR7EIX
Tempra 1.8	159	1.8	66	4	07.93-07.96	835C4.000	0,8	BPR7ES	2023		
Tempra 1.8	159AZ	1.8	66	4	07.93-07.96	835C4.000	0,8	BPR7ES	2023		BPR8EIX
Tempra 1.8	159	1.8	71	4	11.92-10.96	836A5.000	0,8	BPR7ES	2023		
Tempra 1.8	159BY	1.8	74	4	10.94-08.96	836A5.000	0,8	BPR7ES	2023		BPR8EIX
Tempra 1.8	159AV	1.8	76	4	09.93-08.96	835C2.000	0,8	BPR7ES	2023		BPR8EIX
Tempra 1.8 i.e	159	1.8	77	4	02.90-10.96	159A4.046	0,8	BPR7ES	2023	19	BPR8EIX
Tempra 1.8	159	1.8	77	4	03.92-08.96	835C2.000	0,8	BPR7ES	2023		
Tempra 1.8	159	1.8	81	4	03.90-08.96	159A4.000	0,8	BPR7ES	2023		
Tempra 2.0	159AP	2.0	80	4	04.90-06.93	159A6.046	0,8	BPR7ES	2023		BPR8EIX
Tempra S.W./Weekend 2.0	159AP	2.0	80	4	04.91-06.93	159A6.046	0,8	BPR7ES	2023		BPR8EIX
Tempra 2.0	159	2.0	83	4	02.90-10.96	159A6.046	0,8	BPR7ES	2023	19	BPR8EIX

TIPO

Tipo 1.1	160	1.1	41	4	07.87-03.93	160A3.000	0,9	BCPR6ES	2330	12	LPG 3
Tipo 1.4	160	1.4	57	4	01.90-05.95	159A2.000	0,9	BPR6ES	7822	2	LPG 2
Tipo 1.4	356SXA1B	1.4	70	4	10.15-	843A1.000	1,0	DCPR7E-N-10	4983	43	
Tipo 1.4	356	1.4	70	4	01.16-	843A1.000	1,0	DCPR7E-N-10	4983	43	
Tipo 1.4	356WXA1B, 356HXA1B	1.4	70	4	03.16-	843A1.000	1,0	DCPR7E-N-10	4983	43	
Tipo 1.6	160	1.6	55	4	03.93-10.94	835C1.000	0,9	BCPR7ES	3330		BCPR7EIX
Tipo 1.6 iE	160	1.6	55	4	03.93-10.95	835C1.000	0,8	BPR7ES	2023	19	BPR8EIX
Tipo 1.6	160	1.6	57	4	01.92-03.93	159A3.046	0,8	BPR7ES	2023	19	BPR8EIX
Tipo 1.6	160	1.6	63	4	04.90-12.92	159A3.000 DOHC	0,8	BPR7ES	2023	19	BPR8EIX
Tipo 1.6 iE	160	1.6	66	4	03.93-10.95	159A3.048	0,8	BPR7ES	2023	19	BPR8EIX
Tipo 1.6	356SXE11, 356HXE11, 356WXE11	1.6	81	4	10.15-		1,0	ZKR7BI-10	95536		
Tipo 1.8 i.E	160	1.8	76	4	11.91-10.95	835C2.000	0,8	BPR7ES	2023	19	BPR8EIX
Tipo 1.8 i.E. GT	160	1.8	80	4	03.92-03.93	139A4.000	0,8	BPR7ES	2023	19	BPR8EIX
Tipo 1.8 i.E 16V	160	1.8	102	4	06.89-09.91	160A5.000	0,8	BP6ET	1263		LPG 2
Tipo 2.0	160	2.0	83	4	03.90-03.92	159A6.046	0,8	BPR7ES	2023	19	BPR8EIX
Tipo 2.0 GT	160	2.0	83	4	11.91-10.95	159A6.046 Cat	0,8	BPR7ES	2023	19	BPR8EIX
Tipo 2.0 iE 16V	160	2.0	102	4	05.91-10.95	836A3.000 Cat	0,8	BPR7ES	2023	19	BPR8EIX
Tipo 2.0 i.E. 16V	160	2.0	109	4	05.91-10.95	160A8.046	0,8	BPR7ES	2023	19	BPR8EIX

ULYSSE

Ulysse 1.8 iE	220	1.8	73	4	04.96-08.00	LFW	0,9	BKR6EKC	2848	26	
Ulysse 2.0 iE	220	2.0	89	4	07.94-08.00	RFU	0,8	BKR5EK	7956	23	LPG 1
Ulysse 2.0	179	2.0	100	4	09.00-08.02	EW10J4RFN	0,9	LFR5B	7113	46	LPG 7
Ulysse 2.0	220	2.0	100	4	09.00-08.02	RFN	0,9	LFR5B	7113	46	LPG 7
Ulysse 2.0	220	2.0	108	4	07.94-12.98	RGX	0,9	BKR6EK	2288	20	LPG 1
Ulysse 3.0 V6	179	3.0	150	6	06.02-06.11	XFW	1,1	PLFR5A-11	6240		LPG 7

UNO

Uno 45 ES/S/Sting/Trend		0,9	33	4	01.83-10.95	146A_	0,8	BPR6ES	7822	2	LPG 2
Uno 45		1,0	32	4	06.85-10.95	156A2_	0,8	BCPR6ES	2330	12	LPG 3





l kW C
Y
I



Stock-N°

VLINE

LPG/CNG

FIAT

UNO

Uno 1.0L- Start	1.0	33	4	08.94-10.95	156A2.000-156A2.048	0,9	BPR5ES	7422	6	LPG 2
Uno 60 IE / S	1.1	37	4	07.91-10.95	156C.046 Cat	0,8	BCPR6ES	2330	12	LPG 3
Uno 60 SL / Trend	1.1	41	4	09.89-09.92	146A6.000	0,8	BPR6ES	7822	2	LPG 2
Uno 70 all models	1.4	51	4	.83-10.95	160A1.046	0,8	BPR6ES	7822	2	LPG 2
Uno Turbo IE/ Racing	1.4	82	4	09.89-12.93	146A8.046 Cat	0,9	BCPR7ET	2164		BCPR7EIX
Uno 75 I.E. SPi	1.5	55	4	12.87-10.95	149C1.000	0,8	BPR6ES	7822	2	LPG 2

MAREA / MARENGO

Marea 1.4 i. 12 V; Weekend	185	1.4	55	4	10.96-02.98	182A3.000	0,9	BKR6EKC	2848	26	LPG 1
Marea 2.0 i. 155 20 V Weekend	185	2.0	108	5	10.96-12.03	182A1.000	0,9	BKR6EKC	2848	26	LPG 1

FORD

B-MAX

B-Max 1.0 EcoBoost	JK	1.0	74	3	10.12-	SFJA, SFJB	0,7	SILZNR8C7H	93593		
B-Max 1.0 EcoBoost	JK	1.0	88	3	10.12-	M1JA	0,7	SILZNR8C7H	93593		
B-Max 1.0 EcoBoost	JK	1.0	92	3	10.12-	M1JE	0,7	SILZNR8C7H	93593		
B-Max 1.4	JK	1.4	66	4	10.12-	SPJD	1,3	TR5B-13	4559	45	LPG 4
B-Max 1.6 Ti	JK	1.6	77	4	10.12-	IQJA	1,3	TR5B-13	4559	45	LPG 4

C-MAX

C-Max 1.8	DM2	1.8	90	4	02.07-09.10	QQDC	1,3	TR6AP-13	5809		LPG 5
C-Max Hybrid	BV	2.0	101	4	01.15-	20EDEF	1,3	ILTR5K13	90607		

C-MAX 11

C-Max 11 1.0 EcoBoost	BJ	1.0	74	3	10.12-	M2DA	0,7	SILZNR8C7H	93593		
C-Max 11 1.0 EcoBoost	BJ	1.0	92	3	10.12-	M1DA	0,7	SILZNR8C7H	93593		
C-Max 11 1.5 EcoBoost	BV	1.5	110	4	03.15-	M8DB	0,7	ILZNR8A7G	91924		
C-Max 11 1.5 EcoBoost	BV	1.5	134	4	03.15-	M9DB	0,7	ILZNR8A7G	91924		
C-Max 11 1.6 Ti-VCT	BJ	1.6	63	4	09.11-	XTDA	1,3	TR5B-13	4559	45	LPG 4
C-Max 11 1.6 Ti-VCT	BJ	1.6	77	4	12.10-	IQDA, IQDB	1,3	TR5B-13	4559	45	LPG 4
C-Max 11 1.6 Ti-VCT	BJ	1.6	92	4	12.10-	PNDA	1,3	TR5B-13	4559	45	LPG 4
C-Max 11 1.6 EcoBoost	BJ	1.6	110	4	12.10-	JQDA, JQDB	0,8	ILZTR6A8G	94769		
C-Max 11 1.6 EcoBoost	BJ	1.6	134	4	12.10-	JTDA, JTDB	0,8	ILZTR6A8G	94769		

COUGAR

Cougar		2.0	96	4	08.98-01.01	EDBA, EDBB, EDBC, EDBD ZETEC-E SEFI	1,3	PTR5A-13	2467	25	LPG 4
Cougar		2.5	125	6	08.98-01.01	LCBA, LCBB, LCBC, LCBE Duratec-VE SEFI	1,0	PTR5D-10	3784	31	LPG 5
Cougar		2.5	151	6	08.98-01.01	MABB Duratec VE SEFI	1,0	PTR5D-10	3784	31	LPG 5

ECOSPORT

FORD Ecosport 1.5 Ti-VCT	KB	1.5	81	4	10.13-	UEJB, UEJE	1,0	LTR6A-10	90338		
FORD Ecosport 1.5 Ti-VCT	KB	1.5	82	4	10.13-	UEJB, UEJE	1,0	LTR6A-10	90338		

ESCORT '91

Escort '91		1.1	40	4	08.90-09.01	GUF HCS 2V	1,0	PTR5D-10	3784	31	LPG 5
Escort '91		1.3	44	4	08.90-09.01	J4B Endura-E SEFI, J6A HCS CFI, JBE HCS 2V	1,0	PTR5D-10	3784	31	LPG 5
Escort '91		1.3	46	4	08.90-09.01	JBD HCS 2V	1,0	PTR5D-10	3784	31	LPG 5
Escort '91		1.4	52	4	08.90-09.01	F6F CVH CFI, F6G CVH CFI	1,1	BCPR6ES-11	7121	11	LPG 3
Escort '91		1.4	54	4	08.90-09.01	FUH CVH 2V	0,8	BCPR6ES	2330	12	LPG 3
Escort '91		1.4	54	4	08.90-09.01	F4B PTE SEFI	1,1	BCPR6ES-11	7121	11	LPG 3





l kW C
Y
I



Stock-N°

VLINE

LPG/CNG

FORD

ESCORT '91

Escort '91	1.6	65	4	08.90-09.01	L1H ZETEC-E SEFI	1,3	PTR5A-13	2467	25	LPG 4
Escort '91	1.6	66	4	08.90-09.01	LUJ CVH 2V, LUK CVH 2V	0,8	BCPR6ES	2330	12	LPG 3
Escort '91	1.6	66	4	08.90-09.01	L1E ZETEC-E SEFI, L1K ZETEC-E SEFI	1,3	PTR5A-13	2467	25	LPG 4
Escort '91	1.6	77	4	08.90-09.01	LJF CVH EFI	1,1	BCPR6ES-11	7121	11	LPG 3
Escort '91	1.6	79	4	08.90-09.01	LJE CVH EFI	1,1	BCPR6ES-11	7121	11	LPG 3
Escort '91	1.8	77	4	08.90-09.01	RDA ZETEC SEFI	1,3	PTR5A-13	2467	25	LPG 4
Escort '91	1.8	85	4	08.90-09.01	RKC ZETEC-E SEFI	1,3	PTR5A-13	2467	25	LPG 4
Escort '91	1.8	96	4	08.90-09.01	RQB ZETEC SEFI	1,3	PTR5A-13	2467	25	LPG 4
Escort '91	2.0	110	4	08.90-09.01	N7A DOHC 16V EFI	1,1	BCPR6ES-11	7121	11	LPG 3
Escort '91	2.0	162	4	08.90-09.01	N5F DOHC COS-WORTH	0,6	PFR7B	4853		
Escort '91 Cosworth	2.0	162	4	08.90-09.01	N5E DOHC COS-WORTH	1,1	PFR7B-11	5667		
Escort '91 Cosworth	2.0	184	4	.92-	NC8 1711 COSWORTH 16V	0,8	R7436-10	4900		

EXPLORER

Explorer	4.0	115	6	01.93- .03	V6 SEFI	1,5	TR55	3951		LPG 5
Explorer	4.0	121	6	01.93- .03	V6 EFI	1,5	TR55	3951		LPG 5
Explorer	4.0	152	6	01.93- .03	V6 SOHC SEFI	1,5	TR55	3951		LPG 5
Explorer	5.0		8	01.97- .01	V8	1,5	TR55	3951		LPG 5

EXPLORER '20

Explorer 3.0 EcoBoost plug-in Hybrid AWD	NA	3.0	257	6	07.19-	30PDTX	0,8	ILTR6S8	95927		
--	----	-----	-----	---	--------	--------	-----	---------	-------	--	--

FIESTA '01

Fiesta '01	1.25	51	4	11.01-	M7JA Duratec 16V SFI, M7JB Duratec 16V SFI	1,3	PTR5A-13	2467	25	LPG 4
Fiesta '01	1.25	55	4	11.01-	FUJA Duratec 16V SFI, FUJB Duratec 16V SFI	1,3	PTR5A-13	2467	25	LPG 4
Fiesta '01	1.3	44	4	11.01-	BAJA Duratec 8V SFI	1,3	TR5B-13	4559	45	LPG 4
Fiesta '01	1.3	51	4	11.01-	A9JA Duratec 8V SFI, A9JB Duratec 8V SFI	1,3	TR5B-13	4559	45	LPG 4
Fiesta '01 16V	1.4	59	4	11.01-	FXJA Duratec 16V SFI, FXJB Duratec 16V SFI	1,3	PTR5A-13	2467	25	LPG 4
Fiesta '01	1.6	74	4	11.01-	FYJB Duratec 16V SFI	1,3	PTR5A-13	2467	25	LPG 4
Fiesta '01 16V	1.6	74	4	11.01-	FYJA Duratec 16V SFI	1,3	PTR5A-13	2467	25	LPG 4
Fiesta '01 ST150	2.0	110	4	03.05-	N4JB Duratec-ST (M14) SFI	1,3	ITR6F13	4477		LPG 5

FIESTA '08

Fiesta '08 1.0 EcoBoost	JC, JD	1.0	74	3	01.13-	SFJA, SFJB	0,7	SILZNR8C7H	93593		
Fiesta '08 1.0 EcoBoost	JC, JD	1.0	92	3	09.12-	M1JE	0,7	SILZNR8C7H	93593		
Fiesta '08 1.25		1.25	44	4	08.08-	STJA, STJB	1,3	TR5B-13	4559	45	LPG 4
Fiesta '08 1.25		1.25	60	4	08.08-	SNJA, SNJB	1,3	TR5B-13	4559	45	LPG 4
Fiesta '08 1.4 LPG		1.4	68	4	01.09-	RTJA, RTJB	0,8	ILTR6H8G	96870		
Fiesta '08 1.4		1.4	71	4	10.08-	SPJA, SPJC	1,3	TR5B-13	4559	45	LPG 4
Fiesta '08 1.6 Ti		1.6	88	4	10.08-	HXJA, HXJB	1,3	TR5B-13	4559	45	LPG 4
Fiesta '08 1.6 Ti		1.6	99	4	12.10-	U5JA	1,3	TR5B-13	4559	45	LPG 4

FIESTA '12

Fiesta '12 1.0	KC, KD, KR	1.0	48	3	01.13-	XMJA, XMJB, XMJC, XMJD	0,8	LZNR7AI-8G	97576		
Fiesta '12 1.0	KC, KD, KR	1.0	59	3	10.12-	P4JA, P4JB, P4JC, P4JD	0,8	LZNR7AI-8G	97576		





Stock-Nº

VLINE

LPG/CNG

FORD

FIESTA '17

Fiesta '17 1.5 ST EcoBoost	HF, HJ	1.5	147	3	04.18-	YZJA	0,8	DILTR6A8G	90738		
----------------------------	--------	-----	-----	---	--------	------	-----	-----------	-------	--	--

FIESTA '89

Fiesta '89		1.0	33	4	03.89-06.96	TLB HCS 1V	1,0	BPR6EFS	3623	7	LPG 5
Fiesta '89		1.1	37	4	03.89-06.96	G6A HCS CFI	1,0	BPR6EFS	3623	7	LPG 5
Fiesta '89		1.1	40	4	03.89-06.96	GUD HCS 2V, GUE HCS 2V	1,0	BPR6EFS	3623	7	LPG 5
Fiesta '89		1.3	44	4	03.89-06.96	J6B HCS CFI, JBC HCS 2V	1,0	BPR6EFS	3623	7	LPG 5
Fiesta '89		1.4	52	4	03.89-06.96	F6E CVH CFI	1,1	BCPR6ES-11	7121	11	LPG 3
Fiesta '89		1.4	54	4	03.89-06.96	FUJ CVH 2V	0,8	BCPR6ES	2330	12	LPG 3
Fiesta '89		1.4	54	4	03.89-06.96	F4A PTE SEFI, FUG CVH 2V	1,1	BCPR6ES-11	7121	11	LPG 3
Fiesta '89		1.4	55	4	03.89-06.96	FUF CVH 2V	0,8	BCPR6ES	2330	12	LPG 3
Fiesta '89		1.6	66	4	03.89-06.96	LUH CVH 2V	0,8	BCPR6ES	2330	12	LPG 3
Fiesta '89		1.6	66	4	03.89-06.96	L1G ZETEC SEFI	1,3	PTR5A-13	2467	25	LPG 4
Fiesta '89		1.6	76	4	03.89-06.96	LJD CVH EFI	1,1	BCPR6ES-11	7121	11	LPG 3
Fiesta '89		1.6	81	4	03.89-06.96	LJC CVH EFI	1,1	BCPR6ES-11	7121	11	LPG 3
Fiesta '89		1.6	96	4	03.89-06.96	LHA CVH Turbo	0,8	BCR8ES	5430		
Fiesta '89		1.8	77	4	03.89-06.96	RDB ZETEC SEFI	1,3	PTR5A-13	2467	25	LPG 4
Fiesta '89		1.8	96	4	03.89-06.96	RQC ZETEC SEFI	1,3	PTR5A-13	2467	25	LPG 4

FIESTA '96

Fiesta '96		1.25	55	4	11.95-02.02	DHA, DHB, DHC, DHD, DHE, DHF, DHG ZETEC-SE SEFI	1,3	PTR5A-13	2467	25	LPG 4
Fiesta '96		1.3	37	4	11.95-02.02	JJA, JJC, JJE, JJJ, JJK, JJM Endura-E SEFI	1,0	PTR5D-10	3784	31	LPG 5
Fiesta '96		1.3	44	4	11.95-02.02	J4C, J4J, J4L, J4Q, J4R, J4T Endura-E SEFI	1,0	PTR5D-10	3784	31	LPG 5
Fiesta '96		1.4	66	4	11.95-02.02	FHA ZETEC-SE SEFI, FHE ZETEC-SE SEFI	1,3	PTR5A-13	2467	25	LPG 4
Fiesta '96		1.6	76	4	11.95-02.02	L1T ZETEC-SE SEFI, L1V ZETEC-SE SEFI	1,3	PTR5A-13	2467	25	LPG 4

FOCUS

Focus C-Max 1.8	DM2	1.8	90	4	09.05-03.07	QQDC	1,3	ITR6F13	4477		LPG 5
Focus C-Max 1.8	DM2	1.8	90	4	09.05-03.07	QQDC	1,3	TR6AP-13	5809		LPG 5
Focus C-Max 1.8	DM2	1.8	92	4	04.04-08.07	Q7DA, QQDA, QQDB	1,3	ITR6F13	4477		LPG 5
Focus C-Max 2.0	DM2	2.0	107	4	04.04-01.05	AODA, AODB, AODE, SYDA	1,3	ITR6F13	4477		LPG 5

FOCUS '02

Focus / C-Max		1.6	74	4	06.03-	HWDA, HWDB Duratec-16V SFI, SHDA, SHDB Duratec-HE SFI	1,3	TR5B-13	4559	45	LPG 4
Focus / C-Max		1.6	85	4	06.03-	HXDA Duratec-16V Ti-VCT, HXDB Duratec-HE SFI	1,3	TR5B-13	4559	45	LPG 4
Focus / C-Max		1.8	88	4	06.03-	CSDA Duratec-HE SFI, CSDB Duratec-HE SFI	1,3	ITR6F13	4477		LPG 5
Focus / C-Max		1.8	92	4	06.03-	QQDA, QQDB, QQDC Duratec-HE SFI	1,3	TR6AP-13	5809		LPG 5
Focus / C-Max Flexifuel		1.8	92	4	06.03-	Q7DA Duratec-HE SFI	1,3	TR6AP-13	5809		LPG 5
Focus / C-Max		2.0	107	4	04.04-03.07	AODA Duratec-HE SFI, AODB Duratec-HE SFI	1,3	TR6AP-13	5809		LPG 5
Focus / C-Max (LPG / CNG)		2.0	107	4	04.04-03.07	SYDA Duratec-HE SFI	1,3	TR6AP-13	5809		LPG 5
Focus ST 170		2.0	127	4	03.02-11.04	ALDA Duratec-ST	1,0	PLTR6A-10G	3587		





l kW C
Y
I



Stock-N°

VLINE

LPG/CNG

FORD

FOCUS '04

Focus '04	1.4	59	4	07.04-	ASDA Duratec-16V SFI, ASDB Duratec-16V SFI	1,3	TR5B-13	4559	45	LPG 4
Focus '04	1.6	74	4	07.04-	HWDA, HWDB, SHDA, SHDB Duratec-16V SFI	1,3	TR5B-13	4559	45	LPG 4
Focus '04	1.6	85	4	07.04-	HXDA Duratec-16V Ti-VCT, HXDB Duratec-16V Ti-VCT	1,3	TR5B-13	4559	45	LPG 4
Focus '04	1.8	92	4	07.04-	Q7DA Duratec-HE SFI, QQDB Duratec-HE SFI	1,3	TR6AP-13	5809		LPG 5
Focus '04	1.8	92	4	.06-	QQDA Duratec-HE SFI	1,3	TR6AP-13	5809		LPG 5
Focus '04	1.8	96	4	.06-	QQDD Duratec-HE SFI	1,3	TR6AP-13	5809		LPG 5
Focus '04 CNG	2.0	93	4	03.09-	Duratec-HE SFI	1,3	TR6AP-13	5809		LPG 5
Focus '04 LPG	2.0	104	4	03.09-	Duratec-HE SFI	1,3	TR6AP-13	5809		LPG 5
Focus '04	2.0	107	4	07.04-	AODA Duratec-HE SFI, AODB Duratec-HE SFI	1,3	TR6AP-13	5809		LPG 5
Focus '04	2.0	107	4	.06-	SYDA Duratec-HE SFI	1,3	TR6AP-13	5809		LPG 5
Focus ST	2.5	166	5	12.05-	HYDA	0,8	PLFR6A	5472		LPG 7

FOCUS '11

Focus 11 1.0 EcoBoost	DY	1.0	74	3	02.12-	M2DA	0,7	SILZNR8C7H	93593		
Focus 11 1.0 EcoBoost	DY	1.0	92	3	02.12-	M1DA	0,7	SILZNR8C7H	93593		
Focus 1.5 EcoBoost	C4, C5, C6	1.5	110	4	09.14-	M8DA, M8DB	0,7	ILZNR8A7G	91924		
Focus 1.5 EcoBoost	C4, C5, C6	1.5	134	4	09.14-	M9DA, M9DB	0,7	ILZNR8A7G	91924		
Focus 11 1.6 Ti-VCT		1.6	63	4	08.11-	XTDA	1,3	TR5B-13	4559	45	LPG 4
Focus 11 1.6 Ti-VCT		1.6	77	4	04.11-	IQDA, IQDB	1,3	TR5B-13	4559	45	LPG 4
Focus 11 1.6 Flexifuel		1.6	88	4	04.11-	MUDA	1,3	PTR5A-13	2467	25	LPG 4
Focus 11 1.6 Flexifuel		1.6	88	4	04.11-	MUDA	1,3	TR5B-13	4559	45	LPG 4
Focus 11 1.6 Ti-VCT		1.6	92	4	04.11-	PNDA	1,3	TR5B-13	4559	45	LPG 4
Focus 11 1.6 EcoBoost		1.6	110	4	04.11-	JQDA, JQDB	0,8	ILZTR6A8G	94769		
Focus 11 1.6 EcoBoost		1.6	134	4	04.11-	JTDA, JTDB	0,8	ILZTR6A8G	94769		
Focus 11	DYK	2.0	110	4	10.11-	XQDA	0,9	LTR6BI-9	92182		
Focus 11	DYM	2.0	110	4	10.11-	XQDA	0,9	LTR6BI-9	92182		
Focus 11	DYL	2.0	110	4	10.11-	XQDA	0,9	LTR6BI-9	92182		
Ford Focus 2.0 GDi	BL	2.0	125		05.11-06.11	MGDA	0,9	LTR6AI-9	96780		
Focus 11	DYK	2.0	125	4	10.11-	XQDA	0,9	LTR6BI-9	92182		
Focus '11 ST Eco Boost MKIII	DYK	2.0	184	4	07.12-	R9DA	0,8	LTR6DI-8	96588		
Focus ST Eco Boost MK II	DYL	2.0	184	4	07.12-	R9DA	0,8	LTR6DI-8	96588		
Focus '11 RS	C5	2.3	257	4	07.15-01.18	YVDA	0,8	LTR6DI-8	96588		
Focus '11 2.3 RS	C5	2.3	257	4	02.18-	YVDA	0,8	ILTR6R8G	91794		

FOCUS '18

Focus '18 1.5 EcoBoost	HM, HN, HP	1.5	110	3	09.18-	YZDA	0,8	ILTR6R8G	91794		
Focus '18 1.5 EcoBoost	HN, HP	1.5	134	3	09.18-	Y1DA	0,8	ILTR6R8G	91794		
Focus 2.3 ST EcoBoost	HN, HP	2.3	206	4	04.19-	23HD0D	0,8	ILTR6S8	95927		

FOCUS '98

Focus '98		1.4	55	4	08.98-12.04	FXDA, FXDB, FXDC, FXDD ZETEC-SE SEFI	1,3	PTR5A-13	2467	25	LPG 4
Focus '98		1.6	72	4	08.98-12.04	CDDA Duratec SFI	1,3	TR5B-13	4559	45	LPG 4
Focus '98		1.6	74	4	08.98-12.04	FXDA, FXDB, FXDC, FXDD, FXDH ZETEC-SE SEFI	1,3	PTR5A-13	2467	25	LPG 4
Focus '98		1.8	85	4	08.98-12.04	EYDB, EYDC, EYDD, EYDE, EYDF ZETEC-E SFI	1,3	PTR5A-13	2467	25	LPG 4





l kW C
Y I



Stock-N°

VLINE

LPG/CNG

FORD

FOCUS '98

Focus '98 (RUS)	1.8	85	4	08.98-12.04	EYDK ZETEC-E EFI	1,3	PTR5A-13	2467	25	LPG 4
Focus '98	1.8	85	4	08.98-12.04	EYDG, EYDI, EYDJ, EYDL ZETEC-E SFI	1,0	TR5A-10	0005		LPG 4
Focus '98	2.0	96	4	08.98-12.04	EDDB, EDDC, EDDD, EDDF ZETEC-E SFI	1,3	PTR5A-13	2467	25	LPG 4
Focus '98 RS Turbo	2.0	158	4	10.02-12.04	HMDA Duratec RS SFI	1,0	PLTR6A-10G	3587		

FUSION

Fusion	1.25	55	4	06.02-	FUJA Duratec 16V SFI, FUJB Duratec 16V SFI	1,3	PTR5A-13	2467	25	LPG 4
Fusion	1.4	59	4	06.02-	FXJA Duratec 16V SFI, FXJB Duratec 16V SFI	1,3	PTR5A-13	2467	25	LPG 4
Fusion	1.6	74	4	06.02-	FYJA Duratec 16V SFI, FYJB Duratec 16V SFI	1,3	PTR5A-13	2467	25	LPG 4

GALAXY

Galaxy EcoBoost MK II	WM	2.0	149	4	05.11-06.15	TNWA	0,8	LTR6DI-8	96588		
Galaxy EcoBoost MK III	FM	2.0	176	4	04.15-	C20HDTX	0,8	LTR6DI-8	96588		
Galaxy	WA6	2.3	118	4	09.07-06.15	SEWA	1,3	ILTR5K13	90607		

GALAXY '15

Galaxy '15 1.5 EcoBoost	CK	1.5	118	4	01.15-	UNCI, UNCJ UNCK	0,7	ILZNR8A7G	91924		
-------------------------	----	-----	-----	---	--------	-----------------	-----	-----------	-------	--	--

GALAXY '95

Galaxy	2.0	85	4	02.95-03.00	NSE DOHC SEFI	1,1	BKR7EIX-11	6988		BKR8EIX
Galaxy 16V	2.3	107	4	02.95-03.00	Y5B DOHC 16V SEFI	1,1	PFR6G-13E	2341		
Galaxy VR6 4x4	2.8	128	6	02.95-03.98	AAA CD V6 SEFI	0,6	BKR5EKUP	2890		
Galaxy VR6 4x4	2.8	128	6	04.98-03.00	AMY CD V6 SEFI	0,6	BKR5EKUP	2890		

GALAXY 06

Galaxy 06 1.6 EcoBoost	WM	1.6	118	4	02.11-	JTWA, JTWB	0,8	ILZTR6A8G	94769		
Galaxy 06 2.0	WM	2.0	107	4	05.06-	AOWA, AOWB	1,3	TR6AP-13	5809		LPG 5
Galaxy 06 2.0 Flexifuel	WM	2.0	107	4	05.06-	TBWA, TBWB	1,3	TR6AP-13	5809		LPG 5
Galaxy 06 2.0 EcoBoost	WM	2.0	149	4	03.10-	TNWA	0,8	ILTR6G8G	96621		

GALAXY 2000.75

Galaxy /2	2.0	85	4	04.00-02.06	ZVSA DOHC SEFI	1,1	BKR7EIX-11	6988		BKR8EIX
Galaxy /2 16V	2.3	103	4	04.00-02.06	E5SB DOHC 16V SEFI	1,1	PFR6G-13E	2341		
Galaxy /2 16V	2.3	107	4	04.00-02.06	E5SA DOHC 16V SEFI	1,1	PFR6G-13E	2341		
Galaxy /2 24V	2.8	150	6	04.00-02.06	AYL CD V6 24V SEFI	1,1	PZFR5D-11	7968	34	LPG 6

GALAXY VAN

Galaxy EcoBoost MK II	WM	2.0	149	4	05.11-06.15	TNWA	0,8	LTR6DI-8	96588		
-----------------------	----	-----	-----	---	-------------	------	-----	----------	-------	--	--

GRANADA '85

Granada '85	1.8	66	4	05.85-10.94	REC OHC 2V	0,8	APR6FS	2922		
Granada '85	2.0	74	4	05.85-10.94	NE4, NER OHC 2V, NRC OHC EFI	0,8	APR6FS	2922		
Granada '85	2.0	77	4	05.85-10.94	NEL OHC 2V, NEL OHC 2V Cat.	0,8	APR6FS	2922		
Granada '85	2.0	77	4	05.85-10.94	N8D DOHC 2V	0,8	BCPR6ES	2330	12	LPG 3
Granada '85	2.0	80	4	05.85-10.94	N8B DOHC 2V	0,8	BCPR6ES	2330	12	LPG 3
Granada '85	2.0	85	4	05.85-10.94	NRA OHC EFI, NRA OHC EFI Cat., NRI OHC EFI	0,8	APR6FS	2922		
Granada '85	2.0	85	4	05.85-10.94	N9F DOHC EFI	0,8	BCPR6ES	2330	12	LPG 3
Granada '85	2.0	88	4	05.85-10.94	N9D DOHC EFI	0,8	BCPR6ES	2330	12	LPG 3
Granada '85	2.0	90	4	05.85-10.94	N9B DOHC EFI	0,8	BCPR6ES	2330	12	LPG 3
Granada '85	2.4	92	6	05.85-10.94	ARD V6 EFI	1,0	BPR6EFS	3623	7	LPG 5





l kW C
Y
I



Stock-N°

VLINE

LPG/CNG

FORD

GRANADA '85

Granada '85		2.4	96	6	05.85-10.94	ARC V6 EFI	0,8	BCPR6ES	2330	12	LPG 3
Granada '85		2.8	105	6	05.85-10.94	PR4 V6 EFI	0,8	BPR6ES	7822	2	LPG 2
Granada '85		2.8	107	6	05.85-10.94	PR3 V6 EFI	0,8	BPR6ES	7822	2	LPG 2
Granada '85		2.8	110	6	05.85-10.94	PRE V6 EFI	0,8	BPR6ES	7822	2	LPG 2
Granada '85		2.9	107	6	05.85-10.94	BRD, BRE, BRF V6 EFI	1,0	BPR6EFS	3623	7	LPG 5
Granada '85		2.9	110	6	05.85-10.94	BRC V6 EFI	0,8	BCPR6ES	2330	12	LPG 3
Granada '85		2.9	143	6	05.85-10.94	BOA V6 24V EFI	1,1	BKR6EIX-11	3764		LPG 1

GRAND C-MAX 11

Grand C-Max 11 1.0 EcoBoost	BH	1.0	74	3	10.12-	M2DA	0,7	SILZNR8C7H	93593		
Grand C-Max 11 1.0 EcoBoost	BH	1.0	92	3	10.12-	M1DA	0,7	SILZNR8C7H	93593		
Grand C-Max 11 1.5 EcoBoost	BW	1.5	110	4	03.15-	M8DB	0,7	ILZNR8A7G	91924		
Grand C-Max 11 1.5 EcoBoost	BW	1.5	134	4	03.15-	M9DB	0,7	ILZNR8A7G	91924		
Grand C-Max 11 1.6 Ti-VCT	BH	1.6	77	4	12.10-	IQDA, IQDB	1,3	TR5B-13	4559	45	LPG 4
Grand C-Max 11 1.6 Ti-VCT	BH	1.6	92	4	12.10-	PNDA	1,3	TR5B-13	4559	45	LPG 4
Grand C-Max 11 1.6 EcoBoost	BH	1.6	110	4	12.10-	JQDA, JQDB	0,8	ILZTR6A8G	94769		
Grand C-Max 11 1.6 EcoBoost	BH	1.6	134	4	12.10-	JTDA, JTDB	0,8	ILZTR6A8G	94769		

KA '08

Ka '08 1.2	JDU	1.2	51	4	02.09-	FP4	1,0	ZKR7A-10	1691	42	LPG 8
------------	-----	-----	----	---	--------	-----	-----	----------	------	----	-------

KA '96

Ka '96 1.3	RB	1.3	36	4	09.96-	JJD, JJF, JJG, JJH, JJJ Endura-E SEFI	1,0	PTR5D-10	3784	31	LPG 5
Ka '96 1.3	RB	1.3	37	4	09.96-	JJB Endura-E SEFI	1,0	PTR5D-10	3784	31	LPG 5
Ka '96 1.3	RB	1.3	44	4	09.96-	J4D, J4K, J4M, J4N, J4P, J4S Endura-E SEFI	1,0	PTR5D-10	3784	31	LPG 5
Ka '96 1.3	RB	1.3	44	4	09.96-	BAA Duratec 8V SFI	1,3	TR5B-13	4559	45	LPG 4
Ka '96 1.3	RB	1.3	51	4	09.96-	A9A Duratec 8V SFI, A9B Duratec 8V SFI	1,3	TR5B-13	4559	45	LPG 4
Ka '96 1.6	RB	1.6	70	4	09.96-	CDB Duratec 8V SFI, CDC Duratec 8V SFI	1,3	PTR5A-13	2467	25	LPG 4

KUGA II

Kuga II 1.6 EcoBoost	MA	1.6	110	4	11.12-	JQMA, JQMB	0,8	ILZTR6A8G	94769		
Kuga II 1.6 EcoBoost	MA	1.6	134	4	11.12-	JTMA	0,8	ILZTR6A8G	94769		

KUGA III

Kuga III 1.5 EcoBoost	DM2	1.5	88	4	01.16-	BNMA	0,7	ILZNR8A7G	91924		
Kuga III 1.5 EcoBoost	DM2	1.5	110	4	09.14-	M8MA	0,7	ILZNR8A7G	91924		
Kuga III 1.5 EcoBoost	DM2	1.5	134	4	09.14-	M9MA	0,7	ILZNR8A7G	91924		
Kuga 3	DM2	2.5	110	4	01.14-	25HDEX	1,3	ILTR5K13	90607		

MAVERICK '01

Maverick '01 2.0 16V		2.0	91	4	12.00-11.03	YF ZETEC-E SFI	1,3	PTR5A-13	2467	25	LPG 4
Maverick '01 2.3 16V		2.3	110	4	12.03-	GZ Duratec-HE SFI	1,3	ITR6F13	4477		LPG 5
Maverick '01 3.0 V6		3.0	145	6	12.00-11.03	AJ Duratec-VE SFI	1,0	TR5IX	7397		LPG 5
Maverick '01 3.0 V6		3.0	149	6	12.03-	AJ Duratec-VE SFI	1,0	TR5IX	7397		LPG 5

MAVERICK '93

Maverick '93 2.4		2.4	85	4	06.93-04.98	KA24 OHC 12V SEFI	1,1	ZFR5E-11	4435		
Maverick '93 2.4		2.4	87	4	06.93-04.98	KA24 OHC 12V SEFI	1,1	ZFR5E-11	4435		
Maverick '93 2.4		2.4	91	4	06.93-04.98	KA24 OHC 12V SEFI	1,1	ZFR5E-11	4435		

MONDEO

Mondeo Hybrid	CD	2.0	130	4	09.14-	C20EDEF	1,3	ILTR5K13	90607		
---------------	----	-----	-----	---	--------	---------	-----	----------	-------	--	--





l kW C
Y
I



Stock-N°

VLINE

LPG/CNG

FORD

MONDEO

Mondeo EcoBoost MK V	CD	2.0	146	4	05.15-	TNCC	0,8	LTR6DI-8	96588		
Mondeo EcoBoost MK IV	BD	2.0	149	4	03.11-09.14	TNBA	0,8	LTR6DI-8	96588		
Mondeo EcoBoost MK IV	BE	2.0	149	4	03.11-09.14	TNBA	0,8	LTR6DI-8	96588		
Mondeo EcoBoost MK V	CE	2.0	149	4	09.14-	TNCF	0,8	LTR6DI-8	96588		
Mondeo EcoBoost MK V	CD	2.0	149	4	10.14-	TNCD	0,8	LTR6DI-8	96588		
Mondeo EcoBoost MK IV	BD	2.0	176	4	03.11-09.14	TPBA	0,8	LTR6DI-8	96588		
Mondeo EcoBoost MK IV	BE	2.0	176	4	03.11-09.14	TPBA	0,8	LTR6DI-8	96588		
Mondeo EcoBoost MK V	CD, CE	2.0	176	4	09.14-	R9CB, R9CF, R9CH	0,8	LTR6DI-8	96588		
Mondeo	BE	2.3	118	4	09.07-09.14	SEBA	1,3	ILTR5K13	90607		

MONDEO I (1993)

Mondeo I 1.6		1.6	65	4	01.93-07.96	L1J ZETEC-E SEFI	1,3	PTR5A-13	2467	25	LPG 4
Mondeo I 1.6		1.6	66	4	01.93-07.96	L1F ZETEC SEFI	1,3	PTR5A-13	2467	25	LPG 4
Mondeo I 1.8		1.8	82	4	01.93-07.96	RKB ZETEC-E SEFI	1,3	PTR5A-13	2467	25	LPG 4
Mondeo I 1.8		1.8	85	4	01.93-07.96	RKA ZETEC SEFI	1,3	PTR5A-13	2467	25	LPG 4
Mondeo I 2.0		2.0	100	4	01.93-07.96	NGA ZETEC SEFI	1,3	PTR5A-13	2467	25	LPG 4
Mondeo I 2.5		2.5	125	6	01.93-07.96	SEA Duratec-VE SEFI	1,0	PTR5D-10	3784	31	LPG 5

MONDEO II (1997)

Mondeo II 1.6		1.6	65	4	08.96-09.00	L1J ZETEC-E SEFI	1,3	PTR5A-13	2467	25	LPG 4
Mondeo II 1.6		1.6	70	4	08.96-09.00	L1L, L1N, L1Q ZETEC-E SEFI	1,3	PTR5A-13	2467	25	LPG 4
Mondeo II 1.8		1.8	85	4	08.96-09.00	RKB, RKF, RKH, RKJ, RKK ZETEC-E SEFI	1,3	PTR5A-13	2467	25	LPG 4
Mondeo II 2.0		2.0	96	4	08.96-09.00	NGA, NGB, NGC, NGD ZETEC-E SEFI	1,3	PTR5A-13	2467	25	LPG 4
Mondeo II 2.5		2.5	125	6	08.96-09.00	SEA, SEB, SEC Duratec-VE SEFI	1,0	PTR5D-10	3784	31	LPG 5
Mondeo II ST 200		2.5	151	6	08.96-09.00	SGA Duratec-VE SEFI	1,3	PTR6D-13G	6989		LPG 5

MONDEO III (2001)

Mondeo III 1.8		1.8	81	4	10.00-02.07	CGBA Duratec-HE SFI, CGBB Duratec-HE SFI	1,3	PTR6F-13	7569		LPG 5
Mondeo 1.8	B4Y, B5Y	1.8	81	4	09.05-02.07	CGBA, CGBB	1,3	ITR6F13	4477		LPG 5
Mondeo Estate/Wagon 1.8	BWY	1.8	81	4	09.05-02.07	CGBA, CGBB	1,3	ITR6F13	4477		LPG 5
Mondeo III 1.8		1.8	92	4	10.00-02.07	CHBA Duratec-HE SFI, CHBB Duratec-HE SFI	1,3	PTR6F-13	7569		LPG 5
Mondeo 1.8	B4Y, B5Y	1.8	92	4	09.05-02.07	CHBA, CHBB	1,3	ITR6F13	4477		LPG 5
Mondeo Estate/Wagon 1.8	BWY	1.8	92	4	09.05-02.07	CHBA, CHBB	1,3	ITR6F13	4477		LPG 5
Mondeo III 2.0		2.0	107	4	10.00-02.07	CJBA Duratec-HE SFI, CJBB Duratec-HE SFI	1,3	PTR6F-13	7569		LPG 5
Mondeo Estate/Wagon 2.0	BWY	2.0	107	4	10.05-02.07	CJBA, CJBB	1,3	ITR6F13	4477		LPG 5
Mondeo III 2.5 V6		2.5	125	6	10.00-02.07	LCBD Duratec-VE SFI	1,3	PTR5D-13	6644		
Mondeo III 3.0 V6		3.0	150	6	10.00-08.07	REBA Duratec-ST SFI	1,3	PTR6D-13G	6989		LPG 5
Mondeo III ST 220		3.0	166	6	10.00-02.07	MEBA Duratec-ST SFI	1,3	PTR6D-13G	6989		LPG 5

MONDEO IV (2007)

Mondeo IV 1.6 Ti		1.6	81	4	02.07-05.14	RHBA Duratec - 16V Ti-VCT	1,3	TR5B-13	4559	45	LPG 4
Mondeo IV 1.6 Ti		1.6	88	4	07.10-05.14	KGBA	1,3	TR5B-13	4559	45	LPG 4
Mondeo IV 1.6 Ti		1.6	92	4	02.07-05.14	PNBA Duratec - 16V Ti-VCT	1,3	TR5B-13	4559	45	LPG 4
Mondeo IV 1.6 EcoBoost		1.6	118	4	02.11-05.14	JTBA, JTBB	0,8	ILZTR6A8G	94769		
Mondeo IV 2.0		2.0	107	4	02.07-05.14	AOBA, AOBC	1,3	TR6AP-13	5809		LPG 5
Mondeo IV 2.0 Flexifuel		2.0	107	4	03.07-05.14	TBBA, TBBA	1,3	TR6AP-13	5809		LPG 5





l kW C
Y
I



Stock-N°

VLINE

LPG/CNG

FORD

MONDEO IV (2007)

Mondeo IV 2.0 LPG	2.0	107	4	03.09-05.14	TBBA	1,3	TR6AP-13	5809		LPG 5
Mondeo IV 2.0 EcoBoost	2.0	149	4	03.10-05.14	TNBA	0,8	ILTR6G8G	96621		
Mondeo IV 2.0 EcoBoost	2.0	176	4	07.10-05.14	TPBA	0,8	ILTR6G8G	96621		
Mondeo IV 2.3	2.3	118	4	02.07-05.14	SEBA Duratec	1,3	ILTR5A-13G	3811		ILTR6A-13G
Mondeo IV 2.5	2.5	162	5	02.07-05.14	HUBA	0,8	PLFR6A	5472		LPG 7

MONDEO V

Mondeo V 1.5 EcoBoost	CD, CE, CF	1.5	118	4	09.14-	UNCA, UNCB UNCE, UNCF	0,7	ILZNR8A7G	91924		
-----------------------	------------	-----	-----	---	--------	--------------------------	-----	-----------	-------	--	--

ORION '91

Orion '91		1.3	44	4	08.90-07.93	J6A HCS CFI, JBE HCS 2V	1,0	PTR5D-10	3784	31	LPG 5
Orion '91		1.3	46	4	08.90-07.93	JBD HCS 2V	1,0	PTR5D-10	3784	31	LPG 5
Orion '91		1.4	52	4	08.90-07.93	F6F CVH CFI, F6G CVH CFI	1,1	BCPR6ES-11	7121	11	LPG 3
Orion '91		1.4	54	4	08.90-07.93	FUH CVH 2V	0,8	BCPR6ES	2330	12	LPG 3
Orion '91		1.6	66	4	08.90-07.93	LUJ CVH 2V, LUK CVH 2V	0,8	BCPR6ES	2330	12	LPG 3
Orion '91		1.6	66	4	08.90-07.93	L1E ZETEC SEFI	1,3	PTR5A-13	2467	25	LPG 4
Orion '91		1.6	77	4	08.90-07.93	LJF CVH EFI	1,1	BCPR6ES-11	7121	11	LPG 3
Orion '91		1.6	79	4	08.90-07.93	LJE CVH EFI	1,1	BCPR6ES-11	7121	11	LPG 3
Orion '91		1.8	77	4	08.90-07.93	RDA ZETEC SEFI	1,3	PTR5A-13	2467	25	LPG 4
Orion '91		1.8	96	4	08.90-07.93	RQB ZETEC SEFI	1,3	PTR5A-13	2467	25	LPG 4

PROBE

Probe		2.0	85	4	01.93-07.97	FS DOHC 16V SEFI	1,1	BCPR6ES-11	7121	11	LPG 3
Probe GT		2.2	108	4	03.91-12.92	OHC EFI	1,1	ZFR6F-11	4291		LPG 6
Probe		2.5	120	6	01.93-07.97	KL V6 24V EFI	1,1	ZFR6F-11	4291		LPG 6

PUMA '97

Puma '97		1.4	66	4	06.97-12.01	FHD ZETEC-SE SEFI, FHF ZETEC-SE SEFI	1,3	PTR5A-13	2467	25	LPG 4
Puma '97		1.6	76	4	06.97-12.01	L1W ZETEC-SE SFI	1,3	PTR5A-13	2467	25	LPG 4
Puma '97		1.7	92	4	06.97-12.01	MHA ZETEC-S VCT SFI, MHB ZETEC-S VCT SFI	1,3	PTR5A-13	2467	25	LPG 4

SCORPIO '85

Scorpio '85 1.8		1.8	66	4	05.85-10.94	REC OHC 2V	0,8	APR6FS	2922		
Scorpio '85 2.0		2.0	74	4	05.85-10.94	NE4 OHC 2V, NER OHC 2V	0,8	APR6FS	2922		
Scorpio '85 2.0 i		2.0	74	4	05.85-10.94	NRC OHC EFI	0,8	APR6FS	2922		
Scorpio '85 2.0		2.0	77	4	05.85-10.94	NEL OHC 2V, NEL OHC 2V Cat.	0,8	APR6FS	2922		
Scorpio '85 2.0		2.0	77	4	05.85-10.94	N8D DOHC 2V	0,8	BCPR6ES	2330	12	LPG 3
Scorpio '85 2.0		2.0	80	4	05.85-10.94	N8B DOHC 2V	0,8	BCPR6ES	2330	12	LPG 3
Scorpio '85 2.0 i		2.0	85	4	05.85-10.94	NRA OHC EFI, NRA OHC EFI Cat., NRI OHC EFI	0,8	APR6FS	2922		
Scorpio '85 2.0 i		2.0	85	4	05.85-10.94	N9F DOHC EFI	0,8	BCPR6ES	2330	12	LPG 3
Scorpio '85 2.0 i		2.0	88	4	05.85-10.94	N9D DOHC EFI	0,8	BCPR6ES	2330	12	LPG 3
Scorpio '85 2.0 i		2.0	90	4	05.85-10.94	N9B DOHC EFI	0,8	BCPR6ES	2330	12	LPG 3
Scorpio '85 2.4 i V6		2.4	92	6	05.85-10.94	ARD V6 EFI	1,0	BPR6EFS	3623	7	LPG 5
Scorpio '85 2.4 i V6		2.4	96	6	05.85-10.94	ARC V6 EFI	0,8	BCPR6ES	2330	12	LPG 3
Scorpio '85 2.8 i		2.8	105	6	05.85-10.94	PR4 V6 EFI	0,8	BPR6ES	7822	2	LPG 2
Scorpio '85 2.8 i		2.8	107	6	05.85-10.94	PR3 V6 EFI	0,8	BPR6ES	7822	2	LPG 2
Scorpio '85 2.8 i		2.8	110	6	05.85-10.94	PRE V6 EFI	0,8	BPR6ES	7822	2	LPG 2





l kW C
y i



Stock-Nº

VLINE

LPG/CNG

FORD

SCORPIO '85

Scorpio '85 2.9 i	2.9	107	6	05.85-10.94	BRD V6 EFI, BRE V6 EFI, BRF V6 EFI	1,0	BPR6EFS	3623	7	LPG 5
Scorpio '85 2.9 i	2.9	110	6	05.85-10.94	BRC V6 EFI	0,8	BCPR6ES	2330	12	LPG 3
Scorpio '85 2.9 i Cosworth	2.9	143	6	05.85-10.94	BOA V6 24V EFI	1,1	BKR6EIX-11	3764		LPG 1

SCORPIO '95

Scorpio '95 2.0 i	2.0	85	4	10.94-06.98	NSD DOHC 8V SEFI	1,1	PFR6B-11	4014		PFR7B
Scorpio '95 2.0 i	2.0	100	4	10.94-06.98	N3A DOHC 16V SEFI	1,1	PFR6B-11	4014		PFR7B
Scorpio '95 2.3	2.3	108	4	10.94-06.98	Y5A 16V SEFI	1,1	BKR6EIX-11	3764		LPG 1
Scorpio '95 2.9 i	2.9	110	6	10.94-06.98	BRG V6 12V SEFI	1,0	BPR6EFS	3623	7	LPG 5
Scorpio '95 2.9 i Cosworth	2.9	152	6	10.94-06.98	BOB V6 24V SEFI	1,1	PFR6B-11	4014		PFR7B

SIERRA '87

Sierra '87 1.6	1.6	53	4	01.87-12.92	LSF OHC 2V	0,8	APR6FS	2922		
Sierra '87 1.6	1.6	55	4	01.87-12.92	LSE OHC 2V, LSE OHC 2V Cat.	0,8	APR6FS	2922		
Sierra '87 1.6i	1.6	59	4	01.87-12.92	L6B CVH CFI	1,1	BCPR6ES-11	7121	11	LPG 3
Sierra '87 1.8	1.8	59	4	01.87-12.92	RED OHC 2V Cat., REF OHC 2V	0,8	APR6FS	2922		
Sierra '87 1.8	1.8	63	4	01.87-12.92	R6A CVH CFI	1,1	BCPR6ES-11	7121	11	LPG 3
Sierra '87 1.8	1.8	64	4	01.87-12.92	R2C CVH 2V	1,1	BCPR6ES-11	7121	11	LPG 3
Sierra '87 1.8	1.8	66	4	01.87-12.92	RED OHC 2V	0,8	APR6FS	2922		
Sierra '87 1.8	1.8	66	4	01.87-12.92	R2A CVH 2V	1,1	BCPR6ES-11	7121	11	LPG 3
Sierra '87 2.0 i	2.0	74	4	01.87-12.92	N4B OHC EFI, NE5 OHC 2V, NEJ OHC 2V	0,8	APR6FS	2922		
Sierra '87 2.0	2.0	77	4	01.87-12.92	NES OHC 2V, NES OHC 2V Cat.	0,8	APR6FS	2922		
Sierra '87 2.0	2.0	77	4	01.87-12.92	N8C DOHC 2V	0,8	BCPR6ES	2330	12	LPG 3
Sierra '87 2.0	2.0	80	4	01.87-12.92	N8A DOHC 2V	0,8	BCPR6ES	2330	12	LPG 3
Sierra '87 2.0 i	2.0	85	4	01.87-12.92	N4A OHC EFI, N4A OHC EFI Cat., N4I OHC EFI	0,8	APR6FS	2922		
Sierra '87 2.0 i	2.0	85	4	01.87-12.92	N9E DOHC EFI	0,8	BCPR6ES	2330	12	LPG 3
Sierra '87 2.0 i	2.0	88	4	01.87-12.92	N9C DOHC EFI	0,8	BCPR6ES	2330	12	LPG 3
Sierra '87 2.0 i	2.0	90	4	01.87-12.92	N9A DOHC EFI	0,8	BCPR6ES	2330	12	LPG 3
Sierra '87 2.0 RS Cosworth	2.0	150	4	01.87-12.92	N5B DOHC COSWORTH	0,9	R7436-9	4899		
Sierra '87 2.0 16V Cosworth 4x4	2.0	162	4	01.87-12.92	N5C DOHC COSWORTH, N5D DOHC COSWORTH	1,1	PFR7B-11	5667		
Sierra '87 2.8 i	2.8	105	6	01.87-12.92	PR8 V6 EFI	0,8	BPR6ES	7822	2	LPG 2
Sierra '87 2.8 i	2.8	107	6	01.87-12.92	PR7 V6 EFI	0,8	BPR6ES	7822	2	LPG 2
Sierra '87 2.8 i	2.8	110	6	01.87-12.92	PRG V6 FI	0,8	BPR6ES	7822	2	LPG 2
Sierra '87 2.9 i	2.9	107	6	01.87-12.92	B4B V6 EFI, B4C V6 EFI	1,0	BPR6EFS	3623	7	LPG 5
Sierra '87 2.9 i	2.9	110	6	01.87-12.92	B4A V6 EFI	0,8	BCPR6ES	2330	12	LPG 3

S-MAX

S-Max 1.5 EcoBoost	CJ	1.5	118	4	02.15-	UNCI, UNCJ UNCK	0,7	ILZNR8A7G	91924		
S-MAX 1.6 EcoBoost	WS	1.6	118	4	02.11-	JTWA	0,8	ILZTR6A8G	94769		
S-MAX 2.0	WS	2.0	107	4	03.06-	AOWA, AOWB	1,3	TR6AP-13	5809		LPG 5
S-MAX 2.0 Flexifuel	WS	2.0	107	4	05.06-	TBWA, TBWB	1,3	TR6AP-13	5809		LPG 5
S-Max Ecoboost	WS	2.0	146	4	02.11-12.14	TNWB	0,8	LTR6DI-8	96588		
S-MAX 2.0 Ecoboost	WS	2.0	149	4	03.10-	TNWA	0,8	ILTR6G8G	96621		
S-Max Ecoboost	WS	2.0	149	4	05.11-12.14	TNWA	0,8	LTR6DI-8	96588		
S-MAX 2.0 Ecoboost	WS	2.0	176	4	07.10-	TPWA	0,8	ILTR6G8G	96621		





l kW C Y I



Stock-N°

VLINE

LPG/CNG

FORD

S-MAX

S-Max Ecoboost	WS	2.0	176	4	05.11-12.14	TPWA	0,8	LTR6DI-8	96588		
S-Max Ecoboost	FS	2.0	176	4	02.15-	C20HDTX	0,8	LTR6DI-8	96588		
S-Max Ecoboost	WS	2.0	177	4	05.11-12.15	TPWA	0,8	LTR6DI-8	96588		
S-MAX 2.3	WS	2.3	118	4	08.07-	SEWA Duratec-HE	1,3	ILTR5A-13G	3811		ILTR6A-13G
S-Max	WS	2.3	118	4	09.07-12.14	SEWA	1,3	ILTR5K13	90607		
S-MAX 2.5 ST	WS	2.5	162	5	03.06-	HUWA	0,8	PLFR6A	5472		LPG 7

SPORTKA

Sportka		1.6		4	05.03-	Duratec Rocam	1,3	TR5B-13	4559	45	LPG 4
---------	--	-----	--	---	--------	---------------	-----	---------	------	----	-------

STREETKA

Streetka		1.6	70	4	01.03-07.05	CDRB Duratec 8V	1,3	PTR5A-13	2467	25	LPG 4
Streetka		1.6	70	4	01.03-07.05	CDRA Duratec 8V	1,3	TR5B-13	4559	45	LPG 4

TOURNEO CONNECT

Tourneo Connect		1.8	85	4	06.02-	EYPA ZETEC-E SFI	1,3	PTR5A-13	2467	25	LPG 4
Tourneo Connect		1.8	85	4	06.02-	EYPC ZETEC-E SFI	1,0	TR5A-10	0005		LPG 4

TOURNEO CONNECT II

Tourneo Connect II 1.0 EcoBoost	GAD	1.0	74	3	11.13-	M2GA	0,7	SILZNR8C7H	93593		
Tourneo Connect II 1.6 EcoBoost	GAD	1.6	110	4	11.13-	JQGA	0,8	ILZTR6A8G	94769		

TRANSIT '86

Transit '86		1.6	46	4	01.86-07.91	LAC OHC VV, LAT OHC VV	0,8	APR6FS	2922		
Transit '86		2.0	55	4	01.86-07.91	NAV OHC VV	0,8	APR6FS	2922		
Transit '86		2.0	56	4	01.86-07.91	NAW OHC, NAX OHC	0,8	APR6FS	2922		
Transit '86		2.0	57	4	01.86-07.91	N6T OHC CFI, NAT OHC VV	0,8	APR6FS	2922		
Transit '86		2.0	60	4	01.86-07.91	N6TS OHC CFI	0,8	APR6FS	2922		
Transit '86		2.9	110	6	01.86-07.91	B4T V6 EFI	0,8	BCPR6ES	2330	12	LPG 3
Transit '86		3.0	78	6	01.86-07.91	HXC V6 ESX 1V	0,8	BPR6ES	7822	2	LPG 2

TRANSIT '92

Transit '92		2.0	66	4	08.91-07.94	NBA OHC 2V	0,8	APR6FS	2922		
Transit '92		2.0	72	4	08.91-07.94	NCA OHC EFI	0,8	APR6FS	2922		
Transit '92		2.9	107	6	08.91-07.94	BRT V6 EFI	1,1	BCPR6ES-11	7121	11	LPG 3

TRANSIT 2000

Transit 2000 (Rear Wheel Drive)		2.3	107	4	01.00-05.06	E5FA, E5FC	1,1	PFR6B-11	4014		PFR7B
---------------------------------	--	-----	-----	---	-------------	------------	-----	----------	------	--	-------

TRANSIT CONNECT I

Transit Connect I	P65, P70, P80	1.8	85	4	06.02-	EYPA ZETEC-E SFI	1,3	PTR5A-13	2467	25	LPG 4
Transit Connect I	P65, P70, P80	1.8	85	4	06.02-	EYPC ZETEC-E SFI	1,0	TR5A-10	0005		LPG 4

TRANSIT CONNECT II

Transit Connect II 1.0 EcoBoost	GCD	1.0	74	3	11.13-	M2GA	0,7	SILZNR8C7H	93593		
Transit Connect II 1.6 EcoBoost	GCD	1.6	110	4	11.13-	JQGA	0,8	ILZTR6A8G	94769		

WINDSTAR

Windstar		3.0	109	6	10.94-	V6 SEFI	1,0	TR5	2238		LPG 5
----------	--	-----	-----	---	--------	---------	-----	-----	------	--	-------

FORD (USA)

BRONCO

Bronco		4.9		6	.87- .95	Y EFI	1,1	WR4-1	4652		
Bronco		5.0		8	.85- .96	N EFI	1,1	UR4	6630		UR5IX





e kW C
Y
I



Stock-N°

VLINE

LPG/CNG

FORD (USA)

BRONCO

Bronco	5.8		8	.88- .95	H EFI	1,3	UR5	2771		UR6IX
--------	-----	--	---	----------	-------	-----	-----	------	--	-------

BRONCO II

Bronco II	4.0		6	.90-	X EFI	1,5	TR55	3951		LPG 5
-----------	-----	--	---	------	-------	-----	------	------	--	-------

GT

GT	5.4	368	8	09.06-		1,0	TR6	4177		LPG 5
----	-----	-----	---	--------	--	-----	-----	------	--	-------

MUSTANG

Mustang GTDI Ecoboost	P8T	2.3	231	4	12.14-	C23HD0D	0,8	LTR6DI-8	96588		
Mustang (Mexico)		3.0		6	.06-	V6 24V DOHC	1,5	TR55	3951		LPG 5
Mustang		3.8		6	.03-	V6	1,5	TR55	3951		LPG 5
Mustang		4.0		6	.05-	V6	1,1	TR5-1	7060		
Mustang		4.6		8	.03-	V8	1,5	TR55	3951		LPG 5

TAURUS

Taurus		3.0		6	.89- .95	Y DOHC V6 SFI	1,1	PFR5G-11	2647		
Taurus		3.0		6	.92- .99	U OHV V6 SFI	1,0	TR5	2238		LPG 5
Taurus		3.0		6	.96- .99	S DOHC V6 SFI	1,5	TR55	3951		LPG 5
Taurus		3.0		8	.96- .99	N SHO V8 SFI	1,0	TR5	2238		LPG 5
Taurus		3.2		6	.93- .95	P SHO V6 SFI	1,1	PFR5G-11	2647		

THUNDERBIRD

Thunderbird		3.8		6	.89- .95	R EFI V6 EFISupercharged	1,5	TR55-1	2683		
Thunderbird		3.9		8	.03-	A EFI V8 DOHC	1,0	FR5AP-11	5463		
Thunderbird		3.9		8	- .02	A EFI V8 DOHC	1,1	BKR5ES-11	2382	33	LPG 1
Thunderbird		4.6		8	.94- .97	W EFI V8 SOHC	1,5	TR55	3951		LPG 5
Thunderbird		5.0		8	.91- .93	T EFI V8 H O	1,5	UR45	6945		UR5IX

FSO

POLONEZ

Polonez		1.4	75	4	09.93-	16 DOHC Rover	0,8	BKR6ES	3783	28	LPG 1
Polonez		1.5	60	4	07.95-	Cat.	0,8	BP6ET	1263		LPG 2
Polonez		1.6	64	4	07.95-	Cat.	0,8	BP6ET	1263		LPG 2

GAZ (VOLGA)

GAZEL

Gazel Euro3		2.5	119	4	.07-	3M3-405.24	0,8	BKR5ES	2460	35	LPG 1
Gazel		2.5	119	4	.07-	3M3-4052	0,9	BPR5ES	7422	6	LPG 2
Gazel Euro3		2.7	105	4	.07-	3M3-409.10	0,8	BKR5ES	2460	35	LPG 1
Gazel		2.7	105	4	.07-	3M3-409	0,9	BPR5ES	7422	6	LPG 2

SOBOL

Sobol Euro3		2.5	119	4	.07-	3M3-405.24	0,8	BKR5ES	2460	35	LPG 1
Sobol		2.5	119	4	.07-	3M3-4052	0,9	BPR5ES	7422	6	LPG 2
Sobol Euro3		2.7	105	4	.07-	3M3-409.10	0,8	BKR5ES	2460	35	LPG 1
Sobol		2.7	105	4	.07-	3M3-409	0,9	BPR5ES	7422	6	LPG 2

VOLGA

Volga Euro3		2.7	105	4	.07-	3M3-409.10	0,8	BKR5ES	2460	35	LPG 1
Volga		2.7	105	4	.07-	3M3-409	0,9	BPR5ES	7422	6	LPG 2

VOLGA 31105-501

Volga 31105-501		2.4	110		.06-	DCC	1,1	LZTR4A-11	5444		
-----------------	--	-----	-----	--	------	-----	-----	-----------	------	--	--





l kW C
Y I



Stock-N°

VLINE

LPG/CNG

GAZ (VOLGA)

VOLGA 3111

Volga 3111	2.3	107	4	.00-	3M3-4062.10	0,9	BPR5ES	7422	6	LPG 2
Volga 3111	2.5	112	4	.00-	3M3-4052.10	0,9	BPR5ES	7422	6	LPG 2

HOMMEL

BERLINETTE RS

Berlinette RS 16V	2.0	123	4	.98-	XU10.J4RS	0,9	BKR6EK	2288	20	LPG 1
-------------------	-----	-----	---	------	-----------	-----	--------	------	----	-------

HONDA

ACCORD

Accord 1.6 SJ3320C..(3HM)	1.6	59	4	.80-	EL	0,8	BPR6ES	7822	2	LPG 2	
Accord 1.6 SJ3420C..(3HM)	1.6	59	4	.80-	EL	0,8	BPR6ES	7822	2	LPG 2	
Accord 1.6 SJ5320C..(5MT)	1.6	59	4	.80-	EL	0,8	BPR6ES	7822	2	LPG 2	
Accord 1.6 SJ5330C.. Servo	1.6	59	4	.80-	EL	0,8	BPR6ES	7822	2	LPG 2	
Accord 1.6 SJ5420C..(5MT)	1.6	59	4	.80-	EL	0,8	BPR6ES	7822	2	LPG 2	
Accord 1.6 SJ-3320C1..(3HM)	1.6	59	4	02.81-	EL1	0,8	BPR6ES	7822	2	LPG 2	
Accord 1.6 SJ-3420C1..(3HM)	1.6	59	4	.81-	EL1	0,8	BPR6ES	7822	2	LPG 2	
Accord 1.6 SJ-5320C1..(5MT)	1.6	59	4	.81-	EL1	0,8	BPR6ES	7822	2	LPG 2	
Accord 1.6 SJ-5420C1..(5MT)	1.6	59	4	.81-	EL1	0,8	BPR6ES	7822	2	LPG 2	
Accord 1.6 4D AC-5430C..(MT)	1.6	65	4	.84-	EZ	0,8	BPR6ES	7822	2	LPG 2	
Accord 1.6 4D AC-7430C..(AT)	1.6	65	4	.84-	EZ	0,8	BPR6ES	7822	2	LPG 2	
Accord 1.6 2D AC-5320C..(MT)	1.6	65	4	.84-	EZ	1,1	BPR6ES-11	4824	13	LPG 2	
Accord 1.6 2D AC-5330C..(MT)	1.6	65	4	.84-	EZ	1,1	BPR6ES-11	4824	13	LPG 2	
Accord 1.6 2D AC-7330C..(AT)	1.6	65	4	.84-	EZ	1,1	BPR6ES-11	4824	13	LPG 2	
Accord 1.6 L CA-45200C..(MT)	1.6	65	4	.86-	A16A1	1,1	BPR6EY-11	4228	10	LPG 2	
Accord 1.6 L CA-46200C..(AT)	1.6	65	4	.86-	A16A1	1,1	BPR6EY-11	4228	10	LPG 2	
Accord 1.6	CG7	1.6	79	4	10.98-12.02	D16B7	1,1	ZFR5F-11	2262	40	LPG6
Accord 1.6	CG7	1.6	85	4	10.98-12.01	D16B6	1,1	ZFR5F-11	2262	40	LPG6
Accord 1.6	CH5	1.6	85	4	04.99-12.02	D16B6	1,1	ZFR5F-11	2262	40	LPG6
Accord 1.8 2D AD-5330C..(MT)	1.8	74	4	.84-	ET1	1,1	BPR6EY-11	4228	10	LPG 2	
Accord 1.8 2D AD-7330C..(AT)	1.8	74	4	.84-	ET1	1,1	BPR6EY-11	4228	10	LPG 2	
Accord 1.8 4D AD-5430C..(MT)	1.8	74	4	.84-	ET1	1,1	BPR6EY-11	4228	10	LPG 2	
Accord 1.8 4D AD-7430C..(AT)	1.8	74	4	.84-	ET1	1,1	BPR6EY-11	4228	10	LPG 2	
Accord 1.8 i /iLS CE7	1.8	85	4	.96-10.98	F18A3	1,1	ZFR6F-11	4291		LPG 6	
Accord 1.8 iS CG8	1.8	100	4	.99-02.03	F18B2	1,1	ZFR6F-11	4291		LPG 6	
Accord 2.0 CB3..(MT/AT)	2.0	66	4	.90-05.93	F20A2 Cat., F20A6	1,1	ZFR6F-11	4291		LPG 6	
Accord 2.0 EX CA-55300C..(5MT)	2.0	75	4	.86-	A20A1 Cat.	1,1	BPR6EY-11	4228	10	LPG 2	
Accord 2.0 EX CA-56300C..(4AT)	2.0	76	4	.86-	A20A1 Cat.	1,1	BPR6EY-11	4228	10	LPG 2	
Accord 2.0 EX CA-55300C..(MT)	2.0	78	4	.86-	A20A2	1,1	BPR6EY-11	4228	10	LPG 2	
Accord 2.0 EX CA-56300C..(AT)	2.0	78	4	.86-	A20A2	1,1	BPR6EY-11	4228	10	LPG 2	
Accord 2.0i EX CA-55800C..(MT)	2.0	85	4	.87-	A20A3 Cat.	1,1	BPR6EY-11	4228	10	LPG 2	
Accord 2.0i EX CA-56800C..(AT)	2.0	85	4	.87-	A20A3 Cat.	1,1	BPR6EY-11	4228	10	LPG 2	
Accord 2.0i CC7..(MT)	2.0	85	4	.93-	F30Z2	1,1	ZFR6F-11	4291		LPG 6	
Accord 2.0 EXi CA-55400C..(MT)	2.0	90	4	.86-	A20A4	1,1	BPR6EY-11	4228	10	LPG 2	
Accord 2.0 EXi CA-56400C..(AT)	2.0	90	4	.86-	A20A4	1,1	BPR6EY-11	4228	10	LPG 2	
Accord 2.0 S,LS,ES CC7..(MT/AT)	2.0	96	4	.93-	F20Z1	1,1	ZFR6F-11	4291		LPG 6	
Accord 2.0i LS/ES CE8	2.0	96	4	.96-	F20Z1	1,1	ZFR6F-11	4291		LPG 6	





l kW C
Y
I



Stock-N°

VLINE

LPG/CNG

HONDA

ACCORD

Accord 2.0i 16V CA5	2.0	98	4	.88-	B20A8 Cat.	1,1	BCPR6E-11	3132	11	LPG 3	
Accord 2.0i CB3..(MT/AT)	2.0	98	4	01.90-10.98	F20A4	1,1	ZFR6F-11	4291		LPG 6	
Accord 2.0i CB3..(MT/AT)	2.0	98	4	.90-	F20A8	1,1	ZFR6F-11	4291		LPG 6	
Accord 2.0i 16V EX CA-55500C..(MT)	2.0	101	4	.87-	B20A2	1,1	BCPR6EY-N-11	6262		LPG 3	
Accord 2.0iLS / iES CG9	2.0	108	4	.99-02.03	F20B6	1,1	ZFR6F-11	4291		LPG 6	
Accord 2.0i CL7	2.0	114	4	10.02-	K20A6	1,1	ZFR6K-11	6711			
Accord 2.0 Sport CL7	2.0	114	4	10.02-	K20A6	1,1	ZFR6K-11	6711			
Accord 2.0 (CU1 / CW1)	2.0	115	4	06.08-	R20A3	1,1	IZFR6K11NS	9329			
Accord 2.0 iVtec	2.0	115	4	06.08-06.15	R20A3	1,1	SILZKR7C11S	92932			
Accord 2.0 (CU1)	2.0	115	4	07.08-	R20A3	1,1	IZFR6K11NS	9329			
Accord 2.0 iVtec	2.0	115	4	07.08-06.15	R20A3	1,1	SILZKR7C11S	92932			
Accord 2.2i (4WS) CB7..(MT/AT)	2.2	110	4	.90-05.03	F22A3	1,1	ZFR6F-11	4291		LPG 6	
Accord 2.2i VTEC CE9	2.2	110	4	.95-10.98	F22Z2	1,1	ZFR6F-11	4291		LPG 6	
Accord 2.2iR CH1	2.2	156	4	.99-02.03	H22A7	1,1	PZFR6F-11	3271		LPG 6	
Accord 2.3 ES CL3	2.3	113	4	.01-05.03	F23Z5	1,1	ZFR6F-11	4291		LPG 6	
Accord 2.3 SR CC7.. (MT)	2.3	116	4	.93-05.03	H23A3	1,1	ZFR6F-11	4291		LPG 6	
Accord 2.4 iVtec	CR2	2.4	132	4	01.16-	K24W2	1,1	ILKAR7K11S	90255		
Accord 2.4i CL9	2.4	140	4	02.03-	K24A3	1,1	IZFR6K11	6994			
Accord 2.4 Sport CL9	2.4	140	4	02.03-	K24A3	1,1	IZFR6K11	6994			
Accord 2.4 (CU2)	2.4	148	4	.09-	K24Z3	1,1	ILZKR7B11GS	7960			

ACCORD AERO

Accord Aero 2.0 EX CA-53700C..(MT)	2.0	75	4	.87-	A20A1 Cat. 5MT	1,1	BPR6EY-11	4228	10	LPG 2
Accord Aero 2.0 EX CA-54700C..(AT)	2.0	76	4	.87-	A20A1 Cat. 4AT	1,1	BPR6EY-11	4228	10	LPG 2
Accord Aero 2.0 EX CA-53300C..(MT)	2.0	78	4	.86-	A20A2	1,1	BPR6EY-11	4228	10	LPG 2
Accord Aero 2.0 EX CA-54300C..(AT)	2.0	78	4	.86-	A20A2	1,1	BPR6EY-11	4228	10	LPG 2
Accord Aero 2.0i EX CA-53800C..(MT)	2.0	85	4	.87-	A20A3 Cat.	1,1	BPR6EY-11	4228	10	LPG 2
Accord Aero 2.0i EX CA-54800C..(AT)	2.0	85	4	.87-	A20A3 Cat.	1,1	BPR6EY-11	4228	10	LPG 2
Accord Aero 2.0 EXi CA-53400C..(MT)	2.0	90	4	.86-	A20A4	1,1	BPR6EY-11	4228	10	LPG 2
Accord Aero 2.0 EXi CA-54400C..(AT)	2.0	90	4	.86-	A20A4	1,1	BPR6EY-11	4228	10	LPG 2
Accord Aero 2.0i CC9	2.0	98	4	.93-	F20Z3	1,1	ZFR6F-11	4291		LPG 6
Accord Aero 2.0i LS,ES CE2 (MT/AT)	2.0	100	4	.94-	F20B3	1,1	ZFR6F-11	4291		LPG 6
Accord Aero 2.2i CB8	2.2	110	4	.91- .91	F22A7-F22A8	1,1	ZFR6F-11	4291		LPG 6
Accord Aero 2.2i LS,ES CE1 (MT/AT)	2.2	110	4	.94-10.98	F22B5	1,1	ZFR6F-11	4291		LPG 6

ACCORD COUPE

Accord Coupe 2.0 CC1..(MT/AT)	2.0	98	4	.92-	F20A7	1,1	ZFR6F-11	4291		LPG 6	
Accord Coupe 2.0 Vtec	CG4	2.0	107	4	11.99-10.02	F20B7	1,1	ZFR6F-11	4291		LPG 6
Accord Coupe 2.0i ES / iLS (CG4)	2.0	108	4	01.98-	F20B5	1,1	ZFR6F-11	4291		LPG 6	
Accord Coupe 2.2i CD7 (MT/AT)	2.2	110	4	.94-10.98	F22B5	1,1	ZFR6F-11	4291		LPG 6	
Accord Coupe 3.0i V6 CG2	3.0	147	6	.98-	J30A1	1,1	ZFR5F-11	2262	40	LPG6	

ACCORD TOURER

Accord Tourer CM1	2.0	114	4	04.03-	K20A6	1,1	ZFR6K-11	6711		
Accord Tourer CM2	2.4	140	4	04.03-	K24A3	1,1	IZFR6K11	6994		
Accord Tourer 2.4 (CW2)	2.4	148	4	.09-	K24Z3	1,1	ILZKR7B11GS	7960		

CIVIC

Civic 1.0 iVtec	FK6	1.0	93	3	07.18-	P10A2	0,8	ILZKAR8H8S	95112		
-----------------	-----	-----	----	---	--------	-------	-----	------------	-------	--	--





l kW C
Y
I



Stock-N°

VLINE

LPG/CNG

HONDA

CIVIC

Civic 1.0 iVtec	FC9	1.0	93	3	07.18-	P10A4	0,8	ILZKAR8H8S	95112		
Civic 1.0 iVtec	FK6	1.0	95	3	02.17-	P10A2	0,8	ILZKAR8H8S	95112		
Civic 1300 SL-4310S..(4MT)		1.3	33	4	.80-	EN2	0,9	BPR5ES	7422	6	LPG 2
Civic 1300 SL-2320S..(2HM)		1.3	44	4	.80-	EN1	0,9	BPR5ES	7422	6	LPG 2
Civic 1300 SL-5320S..(5MT)		1.3	44	4	.80-	EN1	0,9	BPR5ES	7422	6	LPG 2
Civic 1300 SS-2520S..(2HM)		1.3	44	4	.80-	EN1	0,9	BPR5ES	7422	6	LPG 2
Civic 1300 SS-5520S..(5MT)		1.3	44	4	.80-	EN1	0,9	BPR5ES	7422	6	LPG 2
Civic 1300 WC-2520S..(2HM)		1.3	44	4	.80-	EN1	0,9	BPR5ES	7422	6	LPG 2
Civic 1300 WC-5520S..(5MT)		1.3	44	4	.80-	EN1	0,9	BPR5ES	7422	6	LPG 2
Civic 1300S SL-5330S..(5MT)		1.3	51	4	.82-	EN4	0,8	BPR6ES	7822	2	LPG 2
Civic 1300 AG-3320S..(AT)		1.3	52	4	02.84-	EV2	1,1	BPR6EY-11	4228	10	LPG 2
Civic 1300 AG-5320S..(MT)		1.3	52	4	.84-	EV2	1,1	BPR6EY-11	4228	10	LPG 2
Civic 1.3 EC8..(MT/AT)		1.3	55	4	.88-09.91	D13B1	1,1	BCPR6E-11	3132	11	LPG 3
Civic 1.3 EC8..(MT/AT)		1.3	55	4	.90- .95	D13B2 Cat.	1,1	BCPR6E-11	3132	11	LPG 3
Civic 1.3 EG3		1.3	55	4	.92- .95	D13B2	1,1	BKR6E-11	2756	14	LPG 1
Civic 1.3 IMA Hybrid (ES9) (Twin Spark)		1.3	61	4	.04-	LDA1	1,1	IFR5G-11K	3107		
Civic 1.3i IMA Hybrid (ES9)		1.3	66	4	.03-		1,1	IFR5G-11K	3107		
Civic 1.4	EJ9, MA8, MB2	1.4	55	4	09.95-03.01	D14A3	1,1	BKR5E-11	6953	33	LPG 1
Civic 1.4	EJ9, MA8, MB2	1.4	55	4	09.95-03.01	D14A7	1,1	ZFR5F-11	2262	40	LPG6
Civic 1.4	EJ9, MA8, MB2	1.4	55	4	09.95-03.01	D14Z1	1,1	ZFR5J-11	5584		LPG 6
Civic 1.4	EJ9	1.4	55	4	11.95-10.98	D14A4	1,1	BKR5E-11	6953	33	LPG 1
Civic 1.4i (EJ9)		1.4	55	4	.96-02.01	D14A3	1,1	BKR6E-11	2756	14	LPG 1
Civic 1.4i 5Door MA8		1.4	55	4	.96-	D14A5	1,1	BKR6E-11	2756	14	LPG 1
Civic 1.4 i 5Door MB2		1.4	55	4	.97-	D14A7	1,1	ZFR5F-11	2262	40	LPG6
Civic 1.4i Aerodeck MB8		1.4	55	4	.98-	D14A7	1,1	ZFR6F-11	4291		LPG 6
Civic 1.4i 5Door MB2		1.4	55	4	.99-	D14Z3	1,1	ZFR5F-11	2262	40	LPG6
Civic 1.4i (EJ9)		1.4	55	4	.99-02.01	D14Z1	1,1	ZFR5J-11	5584		LPG 6
Civic 1.4 EC9/ED2..(AT/MT)		1.4	66	4	.88-	D14A1	1,1	BCPR6E-11	3132	11	LPG 3
Civic 1.4	EJ9, MA8, MB2	1.4	66	4	06.95-02.01	D14A4	1,1	BKR5E-11	6953	33	LPG 1
Civic 1.4	EJ9	1.4	66	4	11.95-02.01	D14A4, D14Z2, D14Z4	1,1	BKR5E-11	6953	33	LPG 1
Civic 1.4	EJ9	1.4	66	4	11.95-02.01	D14A4, D14Z2, D14Z4	1,1	ZFR5J-11	5584		LPG 6
Civic 1.4i 5Doorr MA8 (MT/AT)		1.4	66	4	.95-	D14A2	1,1	BKR6E-11	2756	14	LPG 1
Civic 1.4iS (EJ9)		1.4	66	4	.96-02.01	D14A4	1,1	BKR6E-11	2756	14	LPG 1
Civic 1.4 iS 5Door MB2		1.4	66	4	.97-	D14A8	1,1	ZFR5F-11	2262	40	LPG6
Civic 1.4iS Aerodeck MB8		1.4	66	4	.98-	D14A8	1,1	ZFR6F-11	4291		LPG 6
Civic 1.4iS 5Door MB2		1.4	66	4	.99-	D14Z4	1,1	ZFR5F-11	2262	40	LPG6
Civic 1.4iS EJ9		1.4	66	4	.99-12.05	D14Z2	1,1	ZFR5J-11	5584		LPG 6
Civic 1.4	ES4	1.4	66	4	02.01-09.05	D14Z5	1,1	ZFR5J-11	5584		LPG 6
Civic IX 1.4 i-VTEC	FK	1.4	73	4	02.12-	L13Z4	1,3	IZFR6K13	6774		
Civic 5 Door 1.4 (FK1)		1.4	74	4	.09-	L13Z1	1,3	IZFR6K13	6774		
Civic		1.4		4	01.97-	PIJ (SOHC)	1,1	ZFR5F-11	2262	40	LPG6
Civic 1.5S AH-5330S..(MT)		1.5	63	4	.84-	EW2	1,1	BPR6EY-11	4228	10	LPG 2
Civic GL AH-3320S..(AT)		1.5	63	4	.85-	EW2	1,1	BPR6EY-11	4228	10	LPG 2
Civic GL AH-5320S..(MT)		1.5	63	4	.85-	EW2	1,1	BPR6EY-11	4228	10	LPG 2





l kW C
Y
I



Stock-N°

VLINE

LPG/CNG

HONDA

CIVIC

Civic 1.5iGT AH-5330S..(MT)	1.5	66	4	.86-	EW4 Cat.	1,1	BPR6EY-11	4228	10	LPG 2
Civic 1.5i ED6/ED3	1.5	66	4	.89-09.91	D15B2 Cat.	1,1	BCPR6E-11	3132	11	LPG 3
Civic 1.5DXi/LSi EG4/EG8	1.5	66	4	.92-	D15B2	1,1	BKR6E-11	2756	14	LPG 1
Civic 1.5VEI EG4	1.5	66	4	.92-	D15Z1	1,1	ZFR6F-11	4291		LPG 6
Civic 1.5 Vtec MA9	1.5	66	4	07.95-01.97	D15Z3	1,1	ZFR5F-11	2262	40	LPG6
Civic 1.5 VTEC-E 5Door MA9	1.5	66	4	.95-	D15Z3	1,1	ZFR6F-11	4291		LPG 6
Civic 1.5iGT AH-5330S..(MT)	1.5	74	4	.85-	EW3	1,1	BPR6EY-11	4228	10	LPG 2
Civic Coupe 1.5i/LSi EJ2	1.5	74	4	.94-	D15B7	1,1	ZFR6F-11	4291		LPG 6
Civic 1.5 Vtec EK3, MB3	1.5	84	4	11.95-03.01	D15Z6	1,1	ZFR5J-11	5584		LPG 6
Civic 1.5iLS EK3	1.5	84	4	.96-	D15Z6	1,1	ZFR6J-11	5585		LPG 6
Civic Aerodeck 1.5 Vtec MB9	1.5	84	4	02.98-03.00	D15Z8	1,1	ZFR5F-11	2262	40	LPG6
Civic 1.5 Vtec 5Door MB3	1.5	85	4	.97-	D15Z8	1,1	ZFR5F-11	2262	40	LPG6
Civic 1.5iVTEC Aerodeck MB9	1.5	85	4	.98-	D15Z8	1,1	ZFR6F-11	4291		LPG 6
Civic 1.5 iVtec FC1, FK7	1.5	134	4	09.15-	L15B7, L15BA	0,8	ILZKAR8H8S	95112		
Civic P9L(VTEC)	1.5		4	01.97-02.01	D15Z8	1,1	ZFR5F-11	2262	40	LPG6
Civic	1.5		4	.97-	VTi	1,1	BKR6EN-11	5724		
Civic Coupe 1.6 EJ6	1.6	77	4	01.96-12.98	D16Y7	1,1	BKR5E-11	6953	33	LPG 1
Civic Coupe 1.6 LS EJ6	1.6	77	4	.96- .98	D16Y7	1,1	BKR6E-11	2756	14	LPG 1
Civic Coupe 1.6iLS EJ6	1.6	77	4	.99-	D16Y7	1,1	ZFR5F-11	2262	40	LPG6
Civic 1.6 ED4/ED7	1.6	80	4	.88-	D16A6 Cat.	1,1	BCPR6E-11	3132	11	LPG 3
Civic 1.6 ED4/ED7	1.6	81	4	.90- .01	D16Z2 Cat.	1,1	BCPR6E-11	3132	11	LPG 3
Civic 1.6 Vtec EP2, EU6, EU8	1.6	81	4	11.00-09.05	D16V1, D16W7	1,1	ZFR5J-11	5584		LPG 6
Civic 1.6 Vtec ES5	1.6	81	4	04.01-10.04	D16W7	1,1	ZFR5J-11	5584		LPG 6
Civic 1.6 Vtec 5Door EU8	1.6	81	4	.01-	D16V1 SOHC	1,1	ZFR6J-11	5585		LPG 6
Civic 1.6LS 5Door MB1 (MT/AT)	1.6	83	4	.95-	D16Y3	1,1	BKR6E-11	2756	14	LPG 1
Civic 1.6 Vtec EK1	1.6	84	4	11.95-03.01	D16Y5	1,1	ZFR5J-11	5584		LPG 6
Civic 1.6i ES EK1	1.6	84	4	.96-	D16Y5	1,1	ZFR6J-11	5585		LPG 6
Civic 1.6 iVtec FD6	1.6	84	4	09.05-12.12	R16A2	1,1	IZFR6K-11S	5266		
Civic 1.6 LS 5Door MB4	1.6	85	4	.97-	D16B2	1,1	ZFR5F-11	2262	40	LPG6
Civic 1.6iSR Aerodeck MC1	1.6	85	4	.98-	D16B2	1,1	ZFR6F-11	4291		LPG 6
Civic 1.6i/LS 5Door MB4	1.6	85	4	.99-	D16W3	1,1	ZFR5F-11	2262	40	LPG6
Civic 1.6ESI EG5/EG9	1.6	92	4	.92-	D16Z6	1,1	BKR6E-11	2756	14	LPG 1
Civic Coupe 1.6 ESi EJ1	1.6	92	4	.94-	D16Z9	1,1	BKR6E-11	2756	14	LPG 1
Civic 1.6 iVtec EK1	1.6	92	4	11.95-03.01	D16Y8	1,1	BKR5E-11	6953	33	LPG 1
Civic Coupe 1.6 Vtec EJ8	1.6	92	4	01.96-12.98	D16Y8	1,1	BKR5E-11	6953	33	LPG 1
Civic Coupe 1.6i SR EJ8	1.6	92	4	.96-	D16Y8	1,1	BKR6E-11	2756	14	LPG 1
Civic Coupe 1.6i SR EJ8	1.6	92	4	.96- .98	D16Y8	1,1	BKR6E-11	2756	14	LPG 1
Civic Aerodeck 1.6 Vtec MC1	1.6	92	4	04.98-02.01	D16W4	1,1	ZFR5F-11	2262	40	LPG6
Civic 1.6 Vtec MB4	1.6	92	4	11.98-10.00	D16W4	1,1	ZFR5F-11	2262	40	LPG6
Civic Coupe 1.6 SR EJ8	1.6	92	4	.99-	D16Y8	1,1	ZFR5F-11	2262	40	LPG6
Civic 1.6 iVtec FB1, FB7	1.6	92	4	09.11-	R16B1	1,1	SILZKR7C11DS	94742		
Civic 1.6 iVtec FB1, FB7	1.6	92	4	09.11-	R16B1	1,1	SILZKR7C11S	92932		
Civic 1.6 iVtec	1.6	92	4	01.12-	R16B1	1,1	SILZKR7C11DS	94742		
Civic 1.6SR VTEC 5Door MB1 (MT/AT)	1.6	93	4	.95-	D16Y2	1,1	BKR6E-11	2756	14	LPG 1
Civic VTEC EE9	1.6	110	4	.90-	B16A1	1,1	BKR6EN-11	5724		





l kW C
Y
I



Stock-N°

VLINE

LPG/CNG

HONDA

CIVIC

Civic 1.6VTI EG6/EG9		1.6	118	4	.92- .95	B16A2	1,1	BKR6E-11	2756	14	LPG 1
Civic 1.6 Vtec	EK4	1.6	118	4	11.95-09.00	B16A2	1,1	BKR6E-N-11	5724		
Civic 1.6 Vtec	EK4, MB4	1.6	118	4	11.95-12.96	B16A2	1,1	BKR6E-N-11	5724		
Civic 1.6VTI EK4		1.6	118	4	.96-	B16A2	1,1	BKR7EN-11	6256		
Civic 1.6 Vtec	EK4, MB4	1.6	118	4	01.99-02.01	B16A2	1,1	BKR6E-N-11	5724		
Civic Coupe 1.6 Vtec	EM1	1.6	118	4	04.99-12.00	B16A2	1,1	BKR6E-N-11	5724		
Civic Type R EK9		1.6	148	4	-12.01	B16B	1,1	PFR7G-11S	7772		
Civic		1.6		4	01.97-	PIK(SOHC)	1,1	ZFR5F-11	2262	40	LPG6
Civic Coupe 1.7 LS EM2		1.7	88	4	.01-	D17A8	1,1	ZFR6J-11	5585		LPG 6
Civic Coupe 1.7 ES EM2		1.7	92	4	.01-	D17A9	1,1	ZFR6J-11	5585		LPG 6
Civic 1.8 iVtec Flexfuel	FD1	1.8	103	4	11.06-05.13	R18A1	1,1	IZFR6K-11S	5266		
Civic 1.8 iVtec	FB2	1.8	104	4	09.11-	R18Z1	1,1	SILZKR7C11S	92932		
Civic 1.8 iVtec		1.8	104	4	01.12-	R18Z1	1,1	SILZKR7C11DS	94742		
Civic 1.8 iVtec (For OE-No. 12290R41L01)	FK2	1.8	104	4	02.12-	R18Z4	1,1	DILZKR7B11GS	95710		
Civic 1.8 iVtec (For OE-No. 12290R2CT01)		1.8	104	4	02.12-	R18Z4	1,1	SILZKR7C11DS	94742		
Civic 1.8 VTI 5Door MB6		1.8	124	4	.97-	B18C4	1,1	BKR6EN-11	5724		
Civic 1.8iVTi Aerodeck M18C4		1.8	124	4	.98-	B18C4	1,1	BKR7EN-11	6256		
Civic 2.0 Vtec Type R	FK2	2.0	228	4	08.15-	K20C1	0,8	ILZKAR8H8S	95112		
Civic 2.0 iVtec Type R	FK8	2.0	235	4	06.17-	K20C1	0,8	ILZKAR8H8S	95112		

CONCERTO

Concerto 1.5i HW..(MT/AT)		1.5	66	4	.90- .95	D15B2 Cat.	1,1	BCPR6E-11	3132	11	LPG 3
Concerto 1.6i HW..(MT/AT)		1.6	82	4	.90- .95	D16Z2 SOHC Cat.	1,1	BCPR6E-11	3132	11	LPG 3
Concerto 1.6-16V HW		1.6	90	4	.90- .95	D16A8 DOHC	1,1	BCPR6E-11	3132	11	LPG 3

CR-V

CR-V 2.0 iVtec (For OE-No. 12290R1AH01)		2.0	110	4	10.12-	R20A9	1,1	SILZKR7C11S	92932		
CR-V 2.0 iVtec (For OE-No. 12290R41L01)	RE5	2.0	110	4	01.13-	R20A9	1,1	DILZKR7B11GS	95710		
CR-V 2.0 iVtec (For OE-No. 12290R41L01)	RE5	2.0	114	4	10.12-	R20A9	1,1	DILZKR7B11GS	95710		
CR-V 2.0 iVtec (For OE-No. 12290R1AH01)		2.0	114	4	10.12-	R20A9	1,1	SILZKR7C11S	92932		

CR-V 1

CR-V 1 2.0 16V	RD1, RD3	2.0	94	4	02.97-12.00	B20B3, B20B9	1,1	ZFR5F-11	2262	40	LPG6
CR-V 1 2.0 16V	RD1, RD3	2.0	108	4	01.99-02.02	B20Z1, B20Z3	1,1	ZFR6F-11	4291		LPG 6

CR-V 2

CR-V 2 2.0	RD5, RD8	2.0	110	4	03.02-09.06	K20A4	1,1	ZFR6K-11	6711		
CR-V 2 2.4 Vtec	RD7	2.4	118	4	09.01-09.06	K24A1	1,1	ZFR6K-11	6711		

CR-V 3

CR-V 3 2.0	RE5	2.0	110	4	10.06-02.13	R20A2	1,1	IZFR6K-11S	5266		
CR-V 2.0 iVtec	RE5	2.0	110	4	01.07-06.12	R20A2	1,1	IZFR6K-11S	5266		
CR-V 3 2.4	RE4	2.4	118	4	10.06-06.12	K24Z1	1,1	ZFR6K-11	6711		
CR-V 3 2.4 i-VTEC	RE7	2.4	122	4	09.09-06.12	K24Z4	1,1	IZFR6K-11	6994		
CR-V 3 2.4	RE4	2.4	124	4	06.06-06.12	K24Z1	1,1	IZFR6K-11	6994		
CR-V 3 2.4	RE4	2.4	125	4	04.07-06.12	K24Z1, K24A1	1,1	ZFR6K-11	6711		

CR-V 4

HONDA CR-V 4 2.4 iVtec	RM4	2.4	138	4	01.15-	K24W9	1,1	DIL-KAR7G11GS	91578		
------------------------	------------	-----	-----	---	--------	-------	-----	---------------	-------	--	--





l kW C
Y
I



Stock-N°

VLINE

LPG/CNG

HONDA

CR-V 5

HONDA CR-V 5 2.4 iVtec	RW6	2.4	137	4	09.17-	K24W9	1,1	DIL-KAR7G11GS	91578		
------------------------	-----	-----	-----	---	--------	-------	-----	---------------	-------	--	--

CRX

CRX 1.6i-16 ED9		1.6	91	4	.89-	D16Z5 Cat.	1,1	BCPR6E-11	3132	11	LPG 3
CRX 1.6 EH6..(MT/AT)		1.6	92	4	.92-	D16Z6	1,1	BKR6E-11	2756	14	LPG 1
CRX 1.6i-16 ED9		1.6	96	4	.88-	D16A9	1,1	BCPR6E-11	3132	11	LPG 3
CRX VTEC EE8		1.6	110	4	.90-	B16A1	1,1	BKR6EN-11	5724		
CRX 1.6 EG2		1.6	118	4	.92-	B16A2	1,1	BKR6EN-11	5724		

CR-Z

CR-Z 1.5 Hybrid		1.5	84	4	02.10-	LEA1	1,3	DIFR6D13	94167		
-----------------	--	-----	----	---	--------	------	-----	----------	-------	--	--

FR-V

FR-V 1.7 BE1	BE1	1.7	92	4	01.05-09.06	D17A2 SOHC VTEC	1,1	ZFR6J-11	5585		LPG 6
FR-V 1.8 BE1	BE1	1.8	103	4	01.07-	R18A1	1,1	IZFR6K-11S	5266		
FR-V 2.0 BE3	BE3	2.0	110	4	01.05-12.06	K20A9 DOHC i-VTEC	1,1	ZFR6K-11	6711		

HR-V

HR-V 1.5 iVtec	RU1	1.5	96	4	08.15-	L15B4	1,1	DILZKAR7C11S	90137		
HR-V GH2		1.6	77	4	02.99-	D16W1	1,1	ZFR5J-11	5584		LPG 6
HR-V 1.6 VTEC GH2		1.6	91	4	10.99-	VTEC	1,1	ZFR5J-11	5584		LPG 6

INSIGHT

Insight (ZE2)		1.3	65	4	04.09-	LDA3 L4	1,1	DILFR6J11	92491		
---------------	--	-----	----	---	--------	---------	-----	-----------	-------	--	--

INTEGRA

Integra Type-R 16V		2.0	162	4	02.02-	K20A	1,1	IFR7G-11KS	7746		
--------------------	--	-----	-----	---	--------	------	-----	------------	------	--	--

INTEGRA R

Integra R DC2		1.8	140	4	10.97- .99	B18C6	1,1	PFR7G-11	2380		
Integra R DC2		1.8	140	4	.99- .01	B18C6	1,1	PFR7G-11	2380		

JAZZ

Jazz 45 AA-4310S.. (4MT)		1.2	33	4	.84-	ER2	1,1	BPR5EY-11	3028		LPG 2
Jazz 55 AA-3320S.. (3HMT)		1.2	40	4	.85-	ER4	1,1	BPR5EY-11	3028		LPG 2
Jazz 56 AA-5320S.. (5MT)		1.2	41	4	.84-	ER1	1,1	BPR5EY-11	3028		LPG 2
Jazz 1.2 i-DSI (Twin Spark)		1.2	57	4	.02-		1,1	BKR6E-11	2756	14	LPG 1
Jazz 1.2 (GD5) (Twin Spark)		1.2	57	4	.03-	L12A1	1,1	BKR6E-11	2756	14	LPG 1
Jazz 1.2 (GE2) CHAC		1.2	57	4	.06-	L12A4	1,1	BKR6E-11	2756	14	LPG 1
Jazz 1.2 (GG1)	GG1	1.2	66	4	07.08-	L12B1	1,3	DIFR6D13	94167		
Jazz 1.3 (GE3) CHAC		1.3	61	4	.06-	L13A6	1,1	BKR6E-11	2756	14	LPG 1
Jazz 1.3 iVtec	GK3	1.3	75	4	09.15-	L13B2	1,1	DILZKAR7C11S	90137		
Jazz 1.4 (GD1) (Twin Spark)		1.4	61	4	.02-	L13A1	1,1	BKR6E-11	2756	14	LPG 1
Jazz 1.4 (GE3) CHAC		1.4	61	4	.06-	L13A6	1,1	BKR6E-11	2756	14	LPG 1
Jazz 1.3 Hybrid (GP1)	GP1	1.4	65	4	04.11-	LDA3	1,1	DILFR6J11	92491		
Jazz 1.4 (GE6)	GE6	1.4	74	4	07.08-	L13Z1	1,3	DIFR6D13	94167		

LEGEND

Legend V6 2.5i HS..N..(MT)		2.5	110	6	.87-	C25A1 Cat.	1,1	BCPR6E-11	3132	11	LPG 3
Legend V6 2.5i HS..Y..(AT)		2.5	110	6	.87-	C25A1 Cat.	1,1	BCPR6E-11	3132	11	LPG 3
Legend V6 2.5i HS..N..(MT)		2.5	127	6	.87-	C25A1	1,1	BCPR6E-11	3132	11	LPG 3
Legend V6 2.5i HS..Y..(AT)		2.5	127	6	.87-	C25A1	1,1	BCPR6E-11	3132	11	LPG 3
Legend 2.7i HS/KA4		2.7	124	6	.88-02.91	C27A1 Cat.	1,1	BCPR6E-11	3132	11	LPG 3
Legend 3.2 KA7/KA8		3.2	151	6	.91- .96	C32A2	1,1	PFR6G-11	5555		PFR7G





l kW C Y I



Stock-N°

VLINE

LPG/CNG

HONDA

LEGEND

Legend 3.5 V6	3.5	151	6	.95- .04	C35A2	1,1	PFR6G-11	5555		PFR7G
Legend 3.5 V6 KA9	3.5	151	6	.96- .04	C35A5	1,1	PFR6G-11	5555		PFR7G
Legend 3.5 SH-AWD KB1	3.5	217	6	.06-	J35A8	1,1	IZFR6K11	6994		
Legend 3.5 V6 KB1	3.5	217	6	.07-	J35A8	1,1	IZFR6K11	6994		

LEGEND COUPE

Legend Coupe 2.7i KA3	2.7	124	6	.88-	C27A1 Cat.	1,1	BCPR6EY-N-11	6262		LPG 3
-----------------------	-----	-----	---	------	------------	-----	--------------	------	--	-------

LOGO

Logo 1.3 i	1.3	48	4	.99- .01	D13B7	1,1	ZFR5J-11	5584		LPG 6
------------	-----	----	---	----------	-------	-----	----------	------	--	-------

NSX

NSX NA1	3.0	188	6	.91-01.05	C30A3, C30A4	1,1	PFR6G-11	5555		PFR7G
NSX NA2	3.2	206	6	01.97-09.05	C32B2	1,1	PFR6G-11	5555		PFR7G

PILOT

HONDA Pilot 3.5	YF4	3.5	183	6	01.12-06.15	J35Z4	1,1	DILZKR7A11G	92924	
HONDA Pilot 3.5	YF4	3.5	189	6	01.12-06.15	J35Z4	1,1	DILZKR7A11G	92924	

PRELUDE

Prelude 1.8 AB-7230C..(AT)	1.8	74	4	.83- .92	ET	0,8	BPR6EY	6427		LPG 2
Prelude 1.8 AB-5240C..(MT)	1.8	74	4	.85- .92	ET2	1,1	BPR6EY-11	4228	10	LPG 2
Prelude 1.8 AB-5220C..(MT)	1.8	77	4	.83- .92	ET	0,8	BPR6EY	6427		LPG 2
Prelude 1.8 AB-5230C..(MT)	1.8	77	4	.83- .92	ET	0,8	BPR6EY	6427		LPG 2
Prelude 2.0 BA4..(MT/AT)	2.0	80	4	.88-01.92	B20A3 Cat.	1,1	BCPR6EY-N-11	6262		LPG 3
Prelude 2.0 BA4..(MT/AT)	2.0	80	4	.90-01.92	B20A3 Cat.	1,1	BCPR6EY-N-11	6262		LPG 3
Prelude 2.0 BA4..	2.0	84	4	.88-01.92	B20A4	1,1	BCPR6EY-N-11	6262		LPG 3
Prelude 2.0 BB3..(MT/AT)	2.0	98	4	.92-12.99	F20A4	1,1	ZFR6F-11	4291		LPG 6
Prelude 2.0	2.0	98	4	.97-12.99		1,1	ZFR6F-11	4291		LPG 6
Prelude 2.0 i (BB9)	2.0	98	4	.99-12.99	F20A4	1,1	ZFR6F-11	4291		LPG 6
Prelude 2.0i 16V BA2-1300C..(MT)	2.0	101	4	.86- .92	BA20A1 DOHC	1,1	BCPR6E-11	3132	11	LPG 3
Prelude 2.0 16V 4WS)BA4	2.0	101	4	.88-01.92	B20A5 Cat.	1,1	BCPR6EY-N-11	6262		LPG 3
Prelude 2.0 16V 4WS)BA4	2.0	103	4	.90-01.92	B20A9 Cat.	1,1	BCPR6EY-N-11	6262		LPG 3
Prelude 2.2 VTEC BB1..(MT)	2.2	136	4	.93-09.96	H22A2	1,1	PZFR6F-11	3271		LPG 6
Prelude 2.2i	2.2	136	4	.97-12.01	H22A5	1,1	PZFR6F-11	3271		LPG 6
Prelude 2.2 Vti (BB6/BB8)	2.2	136	4	.99-12.01	H22A5	1,1	PZFR6F-11	3271		LPG 6
Prelude 2.3 BB2..(MT/AT)	2.3	118	4	.92-09.96	H23A2	1,1	ZFR6F-11	4291		LPG 6

S 2000

S 2000 (AP1)	2.0	177	4	06.00-	F20C2	1,1	PFR7G-11S	7772		
--------------	-----	-----	---	--------	-------	-----	-----------	------	--	--

SHUTTLE

Shuttle AN-3520S..(AT)	1.5	63	4	.84-	EW2	1,1	BPR6EY-11	4228	10	LPG 2
Shuttle AN-5520S..(MT)	1.5	63	4	.84-	EW2	1,1	BPR6EY-11	4228	10	LPG 2
Shuttle 4WD AR-6520C..(MT)	1.5	63	4	.85-	EW2	1,1	BPR6EY-11	4228	10	LPG 2
Shuttle 2.2i ES	2.2	110	4	.95-12.97	F22 RA1 (AT)	1,1	ZFR6F-11	4291		LPG 6
Shuttle 2.3 RA3	2.3	110	4	.98-05.01	F23A7	1,1	ZFR6F-11	4291		LPG 6

STREAM

Stream (RN1)	1.7	92	4	04.01-	D17A2	1,1	ZFR6J-11	5585		LPG 6
Stream (RN3)	2.0	115	4	04.01-	K20A1	1,1	ZFR6K-11	6711		





l kW C
Y
I



Stock-N°

VLINE

LPG/CNG

HUMMER-AM GENERAL

HUMMER

Hummer H 3	3.4	162	5	.05-		1,3	PTR5A-13	2467	25	LPG 4
Hummer	5.7		8	.94- .96	D EFI V8	1,3	UR5	2771		UR6IX
Hummer H 2	6.0		8	.03- .06	N EFI V8	1,0	TR5	2238		LPG 5
Hummer	8.1		8	.03-	G EFI V8	1,5	PZTR5A-15	7862		

HYUNDAI

ACCENT

Accent 1.3	X3	1.3	44	4	07.94-08.99	G4EH	0,8	BKR5ES	2460		LPG 1
Accent		1.3	44	4	10.94- .99	G4EH	1,1	BKR5ES-11	2382	33	LPG 1
Accent 1.3	X3	1.3	55	4	07.94-08.99	G4EH	0,8	BKR5ES	2460		LPG 1
Accent		1.3	55	4	10.94- .99	G4EH	1,1	BKR5ES-11	2382	33	LPG 1
Accent 1.3	X3	1.3	55	4	10.94-01.00	G4EH	0,8	BKR5ES	2460		LPG 1
Accent/LC		1.3	55	4	.99-03.06	G4EA	1,1	BKR5ES-11	2382	33	LPG 1
Accent/LC		1.3	64	4	.99-03.06	G4EA	1,1	BKR5ES-11	2382	33	LPG 1
Accent 1.4		1.4	71	4	06.06-	G4EE	1,1	BKR5ES-11	2382	33	LPG 1
Accent 1.5	X3	1.5	65	4	09.94-08.99	G4EK	0,8	BKR5ES	2460		LPG 1
Accent 1.5	X3	1.5	65	4	09.94-12.06	G4EK	0,8	BKR5ES	2460		LPG 1
Accent		1.5	65	4	10.94-07.99	G4EK	1,1	BKR5ES-11	2382	33	LPG 1
Accent/LC		1.5	66	4	01.00- .06	G4EB	1,1	BKR5ES-11	2382	33	LPG 1
Accent/LC 16V		1.5	75	4	.99- .06	G4EA	1,1	BKR5ES-11	2382	33	LPG 1
Accent GT 16V		1.5		4	.95-07.99	G4EK	1,1	BKR5ES-11	2382	33	LPG 1
Accent 1.6 (MC)		1.6	82	4	06.06-	G4ED	1,1	BKR5ES-11	2382	33	LPG 1

ACCENT II

Accent 1.3	LC	1.3	55	4	09.99-08.06	G4EA	0,8	BKR5ES	2460		LPG 1
Accent 1.3	LC	1.3	55	4	01.00-09.05	G4EA	0,8	BKR5ES	2460		LPG 1
Accent 1.3	LC	1.3	61	4	01.00-02.03	G4EA	0,8	BKR5ES	2460		LPG 1
Accent 1.3	LC	1.3	62	4	03.03-08.06	G4EA	0,8	BKR5ES	2460		LPG 1
Accent 1.3	LC	1.3	63	4	09.99-02.03	G4EA	0,8	BKR5ES	2460		LPG 1
Accent 1.3	LC	1.3	63	4	09.99-09.05	G4EA	0,8	BKR5ES	2460		LPG 1
Accent 1.5	LC	1.5	66	4	01.00-11.05	G4EB	0,8	BKR5ES	2460		LPG 1
Accent 1.5	LC	1.5	66	4	01.00-12.05	G4EB	0,8	BKR5ES	2460		LPG 1
Accent 1.5	LC	1.5	68	4	09.99-10.02	G4EK	0,8	BKR5ES	2460		LPG 1
Accent 1.5	LC	1.5	68	4	09.99-10.02	G4EK	1,1	BKR5ES-11	2382		LPG 1
Accent 1.5	LC	1.5	69	4	09.99-05.06	G4EK	0,8	BKR5ES	2460		LPG 1
Accent 1.5	LC	1.5	69	4	09.99-05.06	G4EK	1,1	BKR5ES-11	2382		LPG 1
Accent 1.5	LC	1.5	73	4	09.99-08.02	G4FK	1,1	BKR5ES-11	2382		LPG 1
Accent Admire 1.5	LC	1.5	73	4	09.99-02.03	G4FK	1,1	BKR5ES-11	2382		LPG 1
Accent 1.5	LC	1.5	75	4	09.99-10.02	G4FK	1,1	BKR5ES-11	2382		LPG 1
Accent 1.5	LC	1.5	77	4	09.99-08.02	G4FK	1,1	BKR5ES-11	2382		LPG 1

ACCENT IV

Accent 1.4 CVVT	RB	1.4	74	4	11.10-	G4LC	1,0	LKR6D-10E	96569		
Accent 1.4 CVVT	RB	1.4	79	4	11.10-	G4FA	1,0	LZKR6B-10E	1578	49	
Accent 1.6 CVVT	RB	1.6	90	4	11.10-	G4FC	1,0	LZKR6B-10E	1578	49	

ACCENT V

Accent 1.4 CVVT	HCR	1.4	74	4	07.18-	G4LC	1,0	SILKR6C10E	97098		
-----------------	-----	-----	----	---	--------	------	-----	------------	-------	--	--





l kW C
Y
I



Stock-N°

VLINE

LPG/CNG

HYUNDAI

ATOS

Atos		0.8		4	- .02	LPG		0,8	BKR6ES	3783	28	LPG 1
Atos / MX		1.0	40	4	.99- .02	G4HC		1,1	BKR5ES-11	2382	33	LPG 1
Atos Prime		1.0	40	4	.99- .02	G4HC		1,1	BKR5ES-11	2382	33	LPG 1
Atos		1.1	46	4	03.04-			1,1	BKR5ES-11	2382	33	LPG 1

AZERA

Azera 2.4 CVVT	HG	2.4	132	4	07.11-	G4KE		1,1	LFR5A-11	6376		LPG 7
Azera 2.4 CVVT	HG	2.4	148	4	01.11-	G4KE		1,1	LFR5A-11	6376		LPG 7
Azera 2.7 CVVT	TG	2.7	141	6	05.06-12.11	G6BA		1,1	ILFR5B11	1637		ILFR6B
Azera 3.0 MPI	HG	3.0	184	6	03.11-	G6DE		1,1	SILZKR7B11	9723		
Azera 3.3	TG	3.3	198	6	02.07-12.11	G6DB		1,1	IFR5G11	7854		

COUPE

Coupe 1.6	GK	1.6	77	4	02.02-08.09	G4ED		1,1	BKR5ES-11	2382		LPG 1
Coupe 1.6	GK	1.6	79	4	03.02-08.09	G4ED		1,1	BKR5ES-11	2382		LPG 1
Coupe (RD)		1.6	84	4	12.96-04.02	4G61		1,1	BKR5ES-11	2382	33	LPG 1
Coupe 2.0		2.0	99	4	.01-	G4GF-EG		1,1	BKR5ES-11	2382	33	LPG 1
Coupe		2.0	102	4	03.96-09.01	G4GF DOHC		1,1	BKR5ES-11	2382	33	LPG 1
Coupe 2.0		2.0	102	4	.99-	G4GC		1,1	BPR5ES-11	4424		LPG 2
Coupe (GK)		2.0	105	4	03.02-	G4GC-G		1,1	BKR5ES-11	2382	33	LPG 1
Coupe (GK)		2.7	121	6	03.02-	G6BA-G V6		1,1	PFR5J-11	4642		
Coupe 2.7 CVVT	GK	2.7	121	6	01.07-08.09	G6BA		1,1	IFR5G11	7854		
Coupe 2.7 -/CVVT	GK	2.7	123	6	10.04-12.08	G6BA		1,1	IFR5G11	7854		

ELANTRA

Elantra		1.5		4	03.95-06.05			1,1	BKR5E-11	6953	33	LPG 1
Elantra		1.5		4	-02.95			1,1	BPR6ES-11	4824	13	LPG 2
Elantra / XD		1.6	79	4	.00-	G4ED-G DOHC		1,1	BKR5ES-11	2382	33	LPG 1
Elantra		1.6		4	- .99			1,1	BPR6ES-11	4824	13	LPG 2
Elantra / XD		2.0	102	4	.00-	G4GC-G DOHC		1,1	BKR5ES-11	2382	33	LPG 1
Elantra		2.0	105	4	.03-			1,1	BKR5E-11	6953	33	LPG 1
Elantra Lavita 1.6	PN8	1.6	66	4	01.02-12.05	G4ED		0,8	BKR5ES	2460		LPG 1
Elantra Lavita 1.6	PN8	1.6	66	4	01.02-12.05	G4ED		1,1	BKR5ES-11	2382		LPG 1

ELANTRA II

Elantra 1.6	JF2	1.6	66	4	09.95-05.00	G4GR		0,8	BKR5ES	2460		LPG 1
Elantra 1.6	JF2, JF3	1.6	84	4	06.95-05.00	G4GR		0,8	BKR5ES	2460		LPG 1
Elantra 1.6	JF2	1.6	84	4	09.95-05.00	G4GR		0,8	BKR5ES	2460		LPG 1
Elantra 1.8	J2	1.8	94	4	06.95-05.00	G4GM		0,8	BKR5ES	2460		LPG 1
Elantra 1.8	JF2, JF3	1.8	94	4	09.95-05.00	G4GM		0,8	BKR5ES	2460		LPG 1
Elantra 2.0	JF2	2.0	102	4	06.97-05.00	G4GF		0,8	BKR5ES	2460		LPG 1

ELANTRA III

Elantra 1.6	XD	1.6	66	4	06.00-07.03	G4GR		0,8	BKR5ES	2460		LPG 1
Elantra 1.6	XD	1.6	66	4	06.00-07.03	G4GR		1,1	BKR5ES-11	2382		LPG 1
Elantra 1.6	XD	1.6	77	4	01.01-05.06	G4ED		0,8	BKR5ES	2460		LPG 1
Elantra 1.6	XD	1.6	79	4	06.00-07.03	G4ED		0,8	BKR5ES	2460		LPG 1
Elantra 1.6	XD	1.6	79	4	06.00-07.06	G4ED		0,8	BKR5ES	2460		LPG 1
Elantra 1.6	XD	1.6	82	4	08.03-05.06	G4GA		0,8	BKR5ES	2460		LPG 1
Elantra 1.6	XD	1.6	82	4	08.03-05.06	G4GA		1,1	BKR5ES-11	2382		LPG 1





l kW C
Y
I



Stock-N°

VLINE

LPG/CNG

HYUNDAI

ELANTRA III

Elantra 1.8	XD	1.8	97	4	06.00-05.06	G4BB, G4GB	0,8	BKR5ES	2460		LPG 1
Elantra 2.0 CVVT	XD	2.0	102	4	06.00-07.03	G4GC	0,8	BKR5ES	2460		LPG 1
Elantra 2.0	XD	2.0	102	4	06.00-07.03	G4GC	0,8	BKR5ES	2460		LPG 1
Elantra 2.0 CVVT	XD	2.0	104	4	06.00-07.03	G4GC	0,8	BKR5ES	2460		LPG 1
Elantra 2.0 CVVT	XD	2.0	104	4	06.00-07.06	G4GC	0,8	BKR5ES	2460		LPG 1
Elantra 2.0 -/CVVT	XD	2.0	105	4	06.00-08.06	G4GC	0,8	BKR5ES	2460		LPG 1
Elantra 2.0 -/CVVT	XD	2.0	105	4	06.00-08.06	G4GC	1,1	BKR5ES-11	2382		LPG 1
Elantra 2.0 CVVT	XD	2.0	105	4	08.03-09.06	G4GC	0,8	BKR5ES	2460		LPG 1
Elantra 2.0 CVVT	XD	2.0	105	4	08.03-09.06	G4GC	1,1	BKR5ES-11	2382		LPG 1

ELANTRA IV

Elantra 1.6 CVVT	HD	1.6	90	4	06.06-01.09	G4FC	1,1	ZFR5F-11	2262	40	LPG6
Elantra 1.6 CVVT	HD	1.6	90	4	02.09-06.11	G4FC	1,0	LZKR6B-10E	1578	49	
Elantra 2.0 CVVT	HD	2.0	103	4	06.06-05.10	G4GC	1,1	BKR5ES-11	2382		LPG 1
Elantra 2.0 CVVT	HD	2.0	105	4	06.06-05.11	G4GC	1,1	BKR5ES-11	2382		LPG 1

ELANTRA V

Elantra 1.6 CVVT	MD	1.6	96	4	06.11-12.15	G4FG	1,0	LZKR6B-10E	1578	49	
Elantra 1.6 CVVT	MD	1.6	97	4	06.11-08.15	G4FG	1,0	LZKR6B-10E	1578	49	
Elantra 1.8 CVVT	MD, UD	1.8	110	4	07.11-12.16	G4NB	1,1	SILZKR7B11	9723		

ELANTRA VI

Elantra 2.0 MPi	AD	2.0	112	4	10.15-	G4NA	1,1	SILZKR7B11	9723		
-----------------	----	-----	-----	---	--------	------	-----	------------	------	--	--

EQUUS

Equus 3.8	VI	3.8	213	6	03.09-	G6DA	1,1	DILKR6A11	97319		
-----------	----	-----	-----	---	--------	------	-----	-----------	-------	--	--

EXCEL

Excel 1.3	X3	1.3	44	4	01.96-12.96	G4EH	0,8	BKR5ES	2460		LPG 1
Excel 1.3	X3	1.3	55	4	01.95-12.95	G4EH	0,8	BKR5ES	2460		LPG 1
Excel 1.3	X3	1.3	55	4	01.97-12.99	G4EH	0,8	BKR5ES	2460		LPG 1
Excel 1.3	LC	1.3	55	4	09.99-08.06	G4EA	0,8	BKR5ES	2460		LPG 1
Excel 1.3	LC	1.3	63	4	01.00-11.05	G4EA	0,8	BKR5ES	2460		LPG 1
Excel 1.5	X3	1.5	65	4	10.94-01.00	G4EK	0,8	BKR5ES	2460		LPG 1
Excel 1.5	LC	1.5	66	4	01.00-11.05	G4EB	0,8	BKR5ES	2460		LPG 1

GALLOPER

Galopper		3.0	104	6	08.98-	Leaded + LPG	0,9	BPR5ES	7422	6	LPG 2
Galopper		3.0	104	6	08.98-08.01	G6AT Unleaded	1,1	BPR5ES-11	4424		LPG 2
Galopper		3.0		6	.98-08.01	G6AT SOHC V6	1,1	BKR5ES-11	2382	33	LPG 1

GALLOPER II

Galopper 3.0	KNE1CP, KPE1CP	3.0	118	6	11.97-09.01	G6AT	1,1	BPR5ES-11	4424		LPG 2
--------------	-------------------	-----	-----	---	-------------	------	-----	-----------	------	--	-------

GENESIS

Genesis 3.8	BH	3.8	213	6	04.09-12.14	G6DA	1,1	DILKR6A11	97319		
Genesis Prada 3.8 GDi	S4J3	3.8	246	6	01.11-02.11	G6DJ	1,1	DILKR6A11	97319		
Genesis Coupe 3.8 GDi	BK	3.8	255	6	11.11-02.14	G6DJ	1,1	SILZKR7B11	9723		

GETZ

Getz 1.1	TB	1.1	46	4	09.02- .08	G4HD	1,1	BKR5ES-11	2382	33	LPG 1
Getz 1.3	TB	1.3	60	4	09.02- .08	G4EA	1,1	BKR5ES-11	2382	33	LPG 1
Getz 1.4	TB	1.4	71	4	.05- .08	G4EE	1,1	BKR5ES-11	2382	33	LPG 1
Getz 1.6	TB	1.6	78	4	09.02-	G4ED	1,1	BKR5ES-11	2382	33	LPG 1





l kW C
Y
I



Stock-N°

VLINE

LPG/CNG

HYUNDAI

GETZ

Getz 1.6	TB	1.6	78	4	08.05-12.12	G4ED	1,1	BKR5ES-11	2382		LPG 1
----------	----	-----	----	---	-------------	------	-----	-----------	------	--	-------

GRAND SANTA FE III

Grand Santa Fe 3.3 CVVT	NC	3.3	183	6	01.14-	G6DF	1,1	SILZKR7B11	9723		
Grand Santa Fe 3.3 CVVT	NC	3.3	199	6	01.13-	G6DF	1,1	SILZKR7B11	9723		

GRANDEUR

Grandeur 2.4 CVVT	HG	2.4	132	4	01.11-10.16	G4KE	1,1	LFR5A-11	6376		LPG 7
Grandeur 2.5	XG	2.5	120	6	06.02-05.05	G6BV	1,1	PFR5N-11	5838		
Grandeur 2.7 CVVT	TG	2.7	141	6	11.06-10.10	G6BA	1,1	ILFR5B11	1637		ILFR6B
Grandeur 3.0	XG	3.0	153	6	06.02-05.05	G6CT	1,1	PFR5N-11	5838		
Grandeur 3.3	TG	3.3	191	6	11.09-12.11	G6DB	1,1	IFR5G11	7854		

H 1

H 1		2.4	85	4	09.97-	H100	1,1	BPR6ES-11	4824	13	LPG 2
H1 2.4	A1	2.4	82	4	06.97-04.04	G4CS	0,8	BPR6ES	7822		LPG 2
H1 2.4	A1	2.4	99	4	08.02-04.04	G4JS	1,1	PGR5C-11	5760		
H1 2.4	A1	2.4	107	4	11.01-08.07	G4JS	1,1	PGR5C-11	5760		
H1 2.4 CVVT	TQ	2.4	129	4	09.07-	G4KC	1,1	ILFR5B11	1637		ILFR6B
H1 2.4 CVVT	TQ	2.4	129	4	02.08-	G4KC	1,1	ILFR5B11	1637		ILFR6B

H 1 STAREX

H 1 Starex		2.4	82	4	.98-	G4CS	1,1	BPR6ES-11	4824	13	LPG 2
------------	--	-----	----	---	------	------	-----	-----------	------	----	-------

H 100

H100 2.4	KMFFD3WL12, KMFFD3WL7, KMFFD3WL9	2.4	84	4	01.97-03.00	G4CS	1,1	BPR6ES-11	4824	13	LPG 2
H100 2.4	KMFFD2VL3, KMFFD3VE6, KMFFD3VL6	2.4	84	4	08.97-10.03	G4CS	1,1	BPR6ES-11	4824	13	LPG 2
H100 2.4	KMFFD2VL3, KMFFD3VL3, KMFHD2VE3, KMFHD3VE3, KMJFD2WL12, KMJFD2WL9, KMJFD3WL12, KMJFD3WL9, KMJHD2WE12, KMJHD2WE15, KMJHD3WE12, KMJHD3WE15	2.4	90	4	07.93-07.97	G4CS	1,1	BPR6ES-11	4824	13	LPG 2

H 100 I

H 100 i		2.4	84	4	01.97-		1,1	BP6EY-11	4128		LPG 2
---------	--	-----	----	---	--------	--	-----	----------	------	--	-------

H 200

H200 2.4	A1	2.4	82	4	10.97-07.01	G4CS	0,8	BPR6ES	7822		LPG 2
H200 2.4	A1	2.4	82	4	10.98-07.01	G4CS	0,8	BPR6ES	7822		LPG 2
H200 2.4	A1	2.4	99	4	06.01-04.04	G4JS	1,1	PGR5C-11	5760		
H200 2.4	A1	2.4	101	4	02.03-04.04	G4JS	1,1	PGR5C-11	5760		

HIGHWAY VAN

Highway Van 2.0	KMJMF8A, KMJMF8E	2.0	100	4	04.00-03.04	G4CP DOHC	1,1	BPR6ES-11	4824	13	LPG 2
Highway Van 2.0 CVVT	KMJMGF8A, KMJMGF8E, KMJMHF8E	2.0	104	4	11.03-03.04	G4GC	1,1	BKR5ES-11	2382		LPG 1
Highway Van 2.7 CVVT	KMJMFF7C	2.7	127	6	03.00-03.04	G6BA	1,1	IFR5G11	7854		
Highway Van 2.7 CVVT	KMJMFF7C	2.7	127	6	03.00-03.04	G6BA	1,1	PFR5N-11	5838		





l kW C
Y
I



Stock-N°

VLINE

LPG/CNG

HYUNDAI

I10

i10 1.0	PA	1.0	51	3	01.11-12.13	G3LA	1,0	LKR6D-10E	96569		
i10 1.1 (PA)	PA	1.1	49	4	01.08-	G4HG	1,1	BKR5ES-11	2382	33	LPG 1
i10 1.1 (PA)	PA	1.1	51	4	04.11-	G4HG	1,1	BKR5ES-11	2382	33	LPG 1
i10 1.2 (PA)	PA	1.2	57	4	11.08-	G4LA	0,8	PLKR7A	4288		
i10 1.2 LPG	PA	1.2	57	4	01.10-12.13	G4LA	0,8	PLKR7A	4288		
i10 1.2 (PA)	PA	1.2	63	4	04.11-	G4LA	0,8	PLKR7A	4288		

I20

i20 1.2	PB	1.2	56	4	12.08-08.14	G4AG	0,8	PLKR7A	4288		
i20 1.2 (PB)	PB	1.2	57	4	09.08-	G4LA	0,8	PLKR7A	4288		
i20 1.2 LPG	PB	1.2	60	4	01.09-08.14	G4LA	0,8	PLKR7A	4288		
i20 1.4 (PB)	PB	1.4	74	4	09.08-06.09	G4FA	1,1	ZFR5F-11	2262	40	LPG6
i20 1.4 (PB)	PB	1.4	74	4	06.09-	G4FA	1,0	LZKR6B-10E	1578	49	
i20 1.4 CVVT LPG	PB	1.4	75	4	12.08-01.09	G4FA	1,1	ZFR5F-11	2262	40	LPG6
i20 1.4 CVVT LPG	PB	1.4	75	4	02.09-12.12	G4FA	1,0	LZKR6B-10E	1578	49	
i20 1.6		1.6	93	4	09.08-	G4FC	1,1	ZFR5F-11	2262	40	LPG6
i20 1.6		1.6	93	4	01.09-	G4FC	1,0	LZKR6B-10E	1578	49	

I20 2

i20 II 1.0 T-GDi	GB	1.0	74	3	09.15-	G3LC	0,7	ILKR9Q7G	97312		
i20 II 1.0 T-GDi	GB	1.0	88	3	09.15-	G3LC	0,7	ILKR9Q7G	97312		
i20 2, i20 2 Active 1.4 CVVT	GB	1.4	74	4	11.14-	G4LC	1,0	SILKR6C10E	97098		
i20 1.4 CVVT	GB	1.4	74	4	05.15-	G4LC	1,0	SILKR6C10E	97098		

I30 1

i30 I 1.4 (FD)	FD	1.4	77	4	10.07-01.09	G4FA	1,1	ZFR5F-11	2262	40	LPG6
i30 CW I 1.4 CVVT	FD	1.4	77	4	10.07-06.12	G4FA	1,0	LZKR6B-10E	1578	49	
i30 I 1.4 (FD)	FD	1.4	77	4	02.09-	G4FA	1,0	LZKR6B-10E	1578	49	
i30 I 1.4 (FD)	FD	1.4	80	4	06.07-01.09	G4FA	1,1	ZFR5F-11	2262	40	LPG6
i30 CW I 1.4 CVVT LPG	FD	1.4	80	4	01.09-06.12	G4FA	1,0	LZKR6B-10E	1578	49	
i30 I 1.4 (FD)	FD	1.4	80	4	02.09-	G4FA	1,0	LZKR6B-10E	1578	49	
i30 I 1.6 (FD)	FD	1.6	85	4	10.07-01.09	G4FC	1,1	ZFR5F-11	2262	40	LPG6
i30 I 1.6 (FD)	FD	1.6	85	4	02.09-	G4FC	1,0	LZKR6B-10E	1578	49	
i30 I 1.6 (FD)	FD	1.6	90	4	06.07-01.09	G4FC	1,1	ZFR5F-11	2262	40	LPG6
i30 I 1.6 (FD)	FD	1.6	90	4	02.09-	G4FC	1,0	LZKR6B-10E	1578	49	
i30 I 1.6 (FD)	FD	1.6	93	4	02.08-01.09	G4FC	1,1	ZFR5F-11	2262	40	LPG6
i30 I 1.6 (FD)	FD	1.6	93	4	02.09-	G4FC	1,0	LZKR6B-10E	1578	49	
i30 I 2.0 (FD)	FD	2.0	105	4	07.07-	G4GC	1,1	BKR5ES-11	2382	33	LPG 1

I30 2

i30 II 1.4 (GD)	GD	1.4	73	4	11.11-	G4FA	1,0	LZKR6B-10E	1578	49	
i30 1.4	GDE	1.4	73	4	09.12-	G4FA	1,0	LZKR6B-10E	1578	49	
i30 2 1.4 CVVT	GDE, PDE	1.4	74	4	12.14-	G4LC	1,0	SILKR6C10E	97098		
i30 II 1.6 (GD)	GD	1.6	88	4	01.12-	G4FD	1,0	SILZKR6B10E	93815		
i30 1.6 CVVT	GD, GDE	1.6	88	4	06.12-	G4FC	1,0	LZKR6B-10E	1578	49	
i30 1.6 CVVT	GD, GDE	1.6	88	4	05.13-	G4FC	1,0	LZKR6B-10E	1578	49	
i30 II 1.6 GDI (GD)	GD	1.6	95	4	11.11-	G4FD	1,0	SILZKR6B10E	93815		
i30 1.6 CVVT	GD, GDE	1.6	96	4	06.14-	G4FC	1,0	LZKR6B-10E	1578	49	
i30 II 1.6 GDI (GD)	GD	1.6	99	4	11.11-	G4FD	1,0	SILZKR6B10E	93815		





l kW C
Y I



Stock-N°

VLINE

LPG/CNG

HYUNDAI

I30 2

i30 1.6 GDi	GDE	1.6	99	4	05.15-	G4FD	1,0	SILZKR6B10E	93815		
-------------	-----	-----	----	---	--------	------	-----	-------------	-------	--	--

I30 3

i30 III 1.0 T-GDi	PDE	1.0	88	3	11.16-	G3LC	0,7	ILKR9Q7G	97312		
i30 1.4 CVVT	PDE	1.4	73	4	03.17-	G4LC	1,0	SILKR6C10E	97098		
i30 III 1.4 T-GDi	PDE	1.4	103	4	11.16-	G4LD	0,7	ILKR9Q7G	97312		

I30 CW 1

i30 1.4 CVVT LPG	FD	1.4	80	4	01.09-11.11	G4FA	1,0	LZKR6B-10E	1578	49	
i30 CW I 1.4		1.4	80	4	06.09-	G4FA	1,0	LZKR6B-10E	1578	49	
i30 CW I 1.6		1.6	85	4	02.08-01.09	G4FC	1,1	ZFR5F-11	2262	40	LPG6
i30 CW I 1.6		1.6	85	4	02.09-	G4FC	1,0	LZKR6B-10E	1578	49	
i30 CW I 1.6		1.6	90	4	02.08-01.09	G4FC	1,1	ZFR5F-11	2262	40	LPG6
i30 CW I 1.6		1.6	90	4	02.09-	G4FC	1,0	LZKR6B-10E	1578	49	
i30 CW I 1.6		1.6	93	4	02.08-01.09	G4FC	1,1	ZFR5F-11	2262	40	LPG6
i30 CW I 1.6		1.6	93	4	02.09-	G4FC	1,0	LZKR6B-10E	1578	49	
i30 CW I 1.6 GDI		1.6	99	4	11.11-	G4FD	1,0	SILZKR6B10E	93815		
i30 CW I 2.0		2.0	105	4	02.08-	G4GC	1,1	BKR5ES-11	2382	33	LPG 1

I40

i40 1.6	VF	1.6	99	4	07.11-	G4FD	1,0	SILZKR6B10E	93815		
i40 2.0 CVVT	VF	2.0	110	4	10.12-	G4NA	1,1	SILZKR7B11	9723		
i40 2.0 CVVT/GDi	VF	2.0	121	4	03.12-	G4NA, G4NC	1,1	SILZKR7B11	9723		
i40 2.0 GDI	VF	2.0	130	4	07.11-	G4NC	1,1	SILZKR7B11	9723		
i40 2.0 CVVT/GDi	VF	2.0	130	4	07.11-	G4NA	1,1	SILZKR7B11	9723		
i40 2.0 CVVT/GDi	VF	2.0	130	4	10.11-	G4NA, G4NC	1,1	SILZKR7B11	9723		

IX20

ix20 1.4	JC	1.4	66	4	11.10-	G4FA	1,0	LZKR6B-10E	1578	49	
ix20 1.4 CVVT	JC	1.4	74	4	11.10-	G4FA	1,0	LZKR6B-10E	1578	49	
ix20 1.6	JC	1.6	92	4	11.10-	G4FC	1,0	LZKR6B-10E	1578	49	

IX35 (EL)

ix35 2.0 CVVT	EL	2.0	110	4	08.09-07.13	G4KD	1,1	LF5A-11	6376		LPG 7
ix35 2.0 CVVT	EL	2.0	110	4	08.13-12.15	G4NA	1,1	SILZKR7B11	9723		
ix35 2.0 CVVT	EL	2.0	113	4	08.13-12.15	G4NA	1,1	SILZKR7B11	9723		
ix35 2.0 CVVT	EL	2.0	113	4	09.14-12.15	G4NA	1,1	SILZKR7B11	9723		
ix35 2.0 CVVT	EL	2.0	122	4	08.09-07.13	G4KD	1,1	LF5A-11	6376		LPG 7
ix35 2.0 Gdi	EL	2.0	122	4	08.13-12.15	G4NC	1,1	SILZKR7B11	9723		

IX35 (LM)

ix35 1.6	LM	1.6	99	4	09.10-	G4FD	1,0	SILZKR6B10E	93815		
ix35 2.0	LM	2.0	120	4	08.09-	G4KD	1,1	LF5A-11	6376		LPG 7

IX55

ix55 3.8	SH83D	3.8	191	6	09.08-11.12	G6DA	1,1	IFR5G11	7854		
----------	-------	-----	-----	---	-------------	------	-----	---------	------	--	--

KAUAI

Kauai 1.0 T-GDi	OS	1.0	88	3	07.17-	G3LC	0,7	ILKR9Q7G	97312		
-----------------	----	-----	----	---	--------	------	-----	----------	-------	--	--

KONA

Kona 1.0 T-GDi	OS	1.0	88	3	07.17-	G3LC	0,7	ILKR9Q7G	97312		
----------------	----	-----	----	---	--------	------	-----	----------	-------	--	--

LANTRA 1

Lantra 1(J-1)		1.5	63	4	.92-04.95	G4DJ	1,1	BPR6ES-11	4824	13	LPG 2
---------------	--	-----	----	---	-----------	------	-----	-----------	------	----	-------





e kW
C
Y
I



Stock-N°

VLINE

LPG/CNG

HYUNDAI

LANTRA 1

Lantra 1(J-1)		1.6	78	4	.92-04.95	G4CR	1,1	BPR6ES-11	4824	13	LPG 2
Lantra 1(J-1)		1.8	93	4	.92-04.95	G4CN	1,1	BPR6ES-11	4824	13	LPG 2

LANTRA 2

Lantra 1.5	JF2, JF3	1.5	65	4	02.97-05.00	G4EK	0,8	BKR5ES	2460		LPG 1
Lantra Estate/Wagon 1.5	JW2, JW3	1.5	65	4	02.97-05.00	G4EK	0,8	BKR5ES	2460		LPG 1
Lantra Estate/Wagon 1.5	JW2, JW3	1.5	65	4	02.97-05.00	G4EK	1,1	BKR5ES-11	2382		LPG 1
Lantra 1.6	JF2, JF3	1.6	66	4	06.95-05.00	G4GR	0,8	BKR5ES	2460		LPG 1
Lantra 2(J-2)		1.6	66	4	09.95-09.00	G4GR	1,1	BKR5ES-11	2382	33	LPG 1
Lantra Estate/Wagon 1.6	JW2, JW3	1.6	66	4	09.95-05.00	G4GR	0,8	BKR5ES	2460		LPG 1
Lantra 1.6	JF2, JF3	1.6	84	4	06.95-09.00	G4GR	0,8	BKR5ES	2460		LPG 1
Lantra 2(J-2)		1.6	84	4	09.95-09.00	G4GR	1,1	BKR5ES-11	2382	33	LPG 1
Lantra Estate/Wagon 1.6 -/Si	JW2, JW3	1.6	84	4	09.95-05.00	G4GR	0,8	BKR5ES	2460		LPG 1
Lantra 1.6	JF2, JF3	1.6	87	4	06.95-09.00	G4GR	0,8	BKR5ES	2460		LPG 1
Lantra 1.6	JF2, JF3	1.6	87	4	06.95-09.00	G4GR	1,1	BKR5ES-11	2382		LPG 1
Lantra Estate/Wagon 1.6	JW2, JW3	1.6	87	4	06.98-05.00	G4GR	0,8	BKR5ES	2460		LPG 1
Lantra Estate/Wagon 1.6	JW2, JW3	1.6	87	4	06.98-05.00	G4GR	1,1	BKR5ES-11	2382		LPG 1
Lantra 1.8	JF2, JF3	1.8	94	4	06.95-05.00	G4GM	0,8	BKR5ES	2460		LPG 1
Lantra 2(J-2)		1.8	94	4	09.95-09.00	G4GM	1,1	BKR5ES-11	2382	33	LPG 1
Lantra Estate/Wagon 1.8 -/Si	JW2, JW3	1.8	94	4	09.95-05.00	G4GM	0,8	BKR5ES	2460		LPG 1
Lantra 2.0	JF3	2.0	100	4	04.97-05.00	G4JP	0,8	BKR5ES	2460		LPG 1
Lantra Estate/Wagon 2.0	JW3	2.0	100	4	04.97-05.00	G4JP	0,8	BKR5ES	2460		LPG 1
Lantra 2.0	JF3	2.0	100	4	04.97-05.00	G4JP	1,1	BKR5ES-11	2382		LPG 1
Lantra Estate/Wagon 2.0	JW3	2.0	100	4	04.97-05.00	G4JP	1,1	BKR5ES-11	2382		LPG 1
Lantra Estate/Wagon 2.0	JW2, JW3	2.0	102	4	11.95-06.00	G4GF	0,8	BKR5ES	2460		LPG 1
Lantra 2(J-2)		2.0	102	4	02.97- .00		1,1	BKR5ES-11	2382	33	LPG 1
Lantra 2.0	JF2	2.0	102	4	02.97-06.00	G4GF	0,8	BKR5ES	2460		LPG 1

LANTRA 3

Lantra 1.6	XD	1.6	77	4	01.01-05.06	G4ED	0,8	BKR5ES	2460		LPG 1
Lantra 3		1.6	79	4	09.00-	G4ED-G DOHC	1,1	BKR5ES-11	2382	33	LPG 1
Lantra 1.8	XD	1.8	97	4	06.00-07.03	G4BB	0,8	BKR5ES	2460		LPG 1
Lantra 3		2.0	101	4	09.00-	G4GC-G DOHC	1,1	BKR5ES-11	2382	33	LPG 1
Lantra 2.0	XD	2.0	104	4	06.00-07.03	G4GC	0,8	BKR5ES	2460		LPG 1

MATRIX

Matrix 1.6	FC8	1.6	76	4	06.01-08.10	G4ED	1,1	BKR5ES-11	2382		LPG 1
Matrix (FC)		1.6	76	4	08.01-	G4ED	1,1	BKR5ES-11	2382	33	LPG 1
Matrix (FC)		1.8	98	4	07.01-	G4GB	1,1	BKR5ES-11	2382	33	LPG 1

NF 5

NF 2.4 CVVT	NF	2.4	128	4	05.05-12.10	G4KC	1,1	BKR5ES-11	2382		LPG 1
-------------	----	-----	-----	---	-------------	------	-----	-----------	------	--	-------

PONY

Pony		1.2		4	06.74-		0,8	BP5ES	6511	8	LPG 2
Pony		1.4		4	08.77-		0,8	BP5ES	6511	8	LPG 2
Pony 1.5	VA2NAU, VA2NEU, VA3NEU, VD2NAU, VD2NEU, VD3NAU, VD3NEU	1.5	65	4	10.94-01.00	G4EK	0,8	BKR5ES	2460		LPG 1





kw CYI



Stock-N°

VLINE

LPG/CNG

HYUNDAI

PONY / EXEL

Pony/Exel	1.3		4	.85- .94	G13B, G4DG	1,1	BPR6ES-11	4824	13	LPG 2
Pony/Exel	1.5		4	.85- .94	G15B, G4DJ, G15B, G4DJ Cat.	1,1	BPR6ES-11	4824	13	LPG 2

S COUPE

S Coupe N/A	1.5	65	4	04.92-05.96	G4EK	1,1	BKR5ES-11	2382	33	LPG 1
S Coupe Turbo Charge	1.5	85	4	04.91-05.98	G4EK-TC	0,8	BKR6ES	3783	28	LPG 1
S Coupe	1.5		4	.92-	G15B	1,1	BKR5ES-11	2382	33	LPG 1
S Coupe Turbo	1.5		4	.92-		0,8	BKR6ES	3783	28	LPG 1

SANTA FE I (SM)

Santa Fe I 2.0	SM	2.0	99	4	08.01-03.06	G4BP	1,1	BPR6ES-11	4824	13	LPG 2
Santa Fe I 2.4	SM	2.4	100	4	08.00-12.05	G4JS	1,1	PGR5C-11	5760		
Santa Fe I 2.4	SM	2.4	107	4	08.00-12.05	G4JS-G	1,1	PGR5C-11	5760		
Santa Fe I 2.7	SM	2.7	127	6	08.00-12.05	G6BA-G	1,1	PFR5N-11	5838		
Santa Fe 2.7 CVT	SM	2.7	127	6	08.00-03.06	G6BA	0,8	BKR5ES	2460		LPG 1
Santa Fe 2.7 CVT	SM	2.7	129	6	09.02-12.04	G6BA	0,8	BKR5ES	2460		LPG 1

SANTA FE II (CM)

Santa Fe II 2.4	CM	2.4	128	4	11.10-05.13	G4KC, G4KE	1,1	LFR5A-11	6376		LPG 7
Santa Fe II 2.7	CM	2.7	125	6	03.06-09.09	G6BA, G6EA	1,1	ILFR5B11	1637		ILFR6B
Santa Fe II 2.7	CM	2.7	139	6	11.05-12.10	G6BA, G6EA	1,1	ILFR5B11	1637		ILFR6B
Santa Fe 3.5 CVT	CM	3.5	203	6	01.09-05.13	G6DC	1,1	SILZKR7B11	9723		
Santa Fe 3.5 CVT	CM	3.5	204	6	08.11-05.13	G6DC	1,1	SILZKR7B11	9723		

SANTA FE III (DM)

Santa Fe 2.4 CVT	DM	2.4	126	4	06.15-	G4KE	1,1	LFR5A-11	6376		LPG 7
Santa Fe III 2.4 CVT	DM	2.4	129	4	09.12-	G4KE	1,1	DILKR6A11	97319		
Santa Fe III 2.4 GDi	DM	2.4	138	4	05.15-01.17	G4KJ	1,1	DILKR6A11	97319		
Santa Fe III 2.4 CVT GDi	DM	2.4	141	4	09.12-	G4KJ	1,1	DILKR6A11	97319		

SANTA FE IV (TM)

Santa Fe 2.4 MPi	TM	2.4	127	4	07.18-	G4KE	1,1	LFR5A-11	6376		LPG 7
------------------	----	-----	-----	---	--------	------	-----	----------	------	--	-------

SANTAMO

Santamo		2.0	101	4	.99-12.02	G4CP DOHC, SOHC	1,1	BP6ES-11	1212		LPG 2
---------	--	-----	-----	---	-----------	-----------------	-----	----------	------	--	-------

SATELLITE

Satellite 2.4	A1	2.4	82	4	08.97-07.01	G4CS	0,8	BPR6ES	7822		LPG 2
Satellite 2.4	A1	2.4	82	4	09.99-07.01	G4CS	0,8	BPR6ES	7822		LPG 2

SCOUPE

Scoupe 1.5	E2JA, E2JE, E3JA, E3JE, UE2, UE3	1.5	62	4	03.90-12.92	G4DJ	1,1	BPR6ES-11	4824	13	LPG 2
------------	----------------------------------	-----	----	---	-------------	------	-----	-----------	------	----	-------

SOLARIS

Solaris 1.4 CVT	HCR	1.4	74	4	01.17-	G4LC	1,0	SILKR6C10E	97098		
Solaris 1.4 CVT	RB	1.4	79	4	11.10-	G4FA	1,0	LZKR6B-10E	1578	49	
Solaris 1.4 VVTi	RB	1.4	79	4	11.10-	G4FA	1,0	LZKR6B-10E	1578	49	
Solaris 1.6 CVT	RB	1.6	90	4	11.10-	G4FC	1,0	LZKR6B-10E	1578	49	
Solaris 1.6 CVT	RB	1.6	90	4	02.11-	G4FC	1,0	LZKR6B-10E	1578	49	

SONATA

Sonata 1.8	Y3	1.8	63	4	07.96-05.98	G4DM	1,1	BPR6ES-11	4824	13	LPG 2
Sonata 1.8i		1.8	70	4	.89-	G62B	1,1	BPR6ES-11	4824	13	LPG 2
Sonata 1.8	Y3	1.8	72	4	06.93-06.98	G4CM	0,8	BPR6ES	7822		LPG 2





l kW C
Y
I



Stock-N°

VLINE

LPG/CNG

HYUNDAI

SONATA

Sonata 2.0i		2.0	74	4	.89- .93	4G63 DOHC	1,1	BPR6ES-11	4824	13	LPG 2
Sonata 2.0	Y3	2.0	77	4	06.93-06.96	G4CP	1,1	BPR6ES-11	4824	13	LPG 2
Sonata 2.0i		2.0	77	4	06.94- .96	G4CP-D SOHC	1,1	BUR6EA-11	5428		
Sonata 2.0	Y3	2.0	92	4	06.96-06.98	G4CP DOHC	1,1	BPR6ES-11	4824	13	LPG 2
Sonata 2.0 EF		2.0	100	4	09.98- .01	G4JP-G DOHC	1,1	BPR6ES-11	4824	13	LPG 2
Sonata 2.0 CVVT	EF	2.0	106	4	06.01-04.05	GCBPE	1,1	BPR6ES-11	4824	13	LPG 2
Sonata 2.0 CVVT	NF	2.0	106	4	05.05-11.10	G4KA	1,1	BKR5ES-11	2382		LPG 1
Sonata 2.0 CVVT	YF	2.0	110	4	06.09-06.14	G4KD	1,1	LFR5A-11	6376		LPG 7
Sonata 2.0 CVVT	LF	2.0	110	4	11.18-	G4NA	1,1	SILZKR7B11	9723		
Sonata 2.0 CVVT	NF	2.0	119	4	07.08-12.10	G4KD	1,1	LFR5A-11	6376		LPG 7
Sonata 2.0 CVVT	NF	2.0	121	4	03.09-12.10	G4KD	1,1	BKR5ES-11	2382		LPG 1
Sonata 2.0i		2.0		4	.93- .98	G4CP-D DOHC	1,1	BPR6ES-11	4824	13	LPG 2
Sonata 2.4	EF	2.4	105	4	06.98-05.01	G4BS	1,1	PGR5C-11	5760		
Sonata 2.4i (NF)		2.4	118	4	.89- .01	G4KC	1,1	BKR5ES-11	2382	33	LPG 1
Sonata 2.4i		2.4	120	4	.89-	4G64	1,1	BPR6ES-11	4824	13	LPG 2
Sonata 2.4i		2.4	121	4	.08-		1,1	BKR5ES-11	2382	33	LPG 1
Sonata VI 2.4 (YF)		2.4	131	4	01.09-	G4KC	1,1	LFR5A-11	6376		LPG 7
Sonata 2.4 CVVT	YF	2.4	131	4	11.10-12.14	G4KC	1,1	LFR5A-11	6376		LPG 7
Sonata 2.5 V6		2.5	118	6	09.98- .01	G6BV-EG DOHC	1,1	PFR5J-11	4642		
Sonata 2.7 -/CVVT	EF	2.7	127	6	06.01-12.05	G6BA	1,1	PFR5N-11	5838		
Sonata 2.7 V6		2.7	127	6	10.01-11.04	G6BA-G	1,1	PFR5B-11	2300		PFR6B
Sonata 3.0 V6		3.0		6	.91- .98	G6AT	1,1	PGR5A-11	3573		
Sonata 3.3 V6 (NF)		3.3	173	6	01.05- .08	G6DB	1,1	IFR5G11	7854		
Sonata 3.3 CVVT	NF	3.3	184	6	01.08-11.10	G6DB	1,1	IFR5G11	7854		
Sonata 3.3 CVVT	NF	3.3	186	6	09.07-12.08	G6DB	1,1	IFR5G11	7854		

SONICA

Sonica 2.0	Y3	2.0	92	4	07.96-05.98	G4JPE	1,1	BPR6ES-11	4824	13	LPG 2
Sonica 2.0	Y3	2.0	96	4	07.94-10.94	G4CP	1,1	BPR6ES-11	4824	13	LPG 2
Sonica 2.7 CVVT	EF	2.7	127	6	06.01-04.05	G6BA	1,1	PFR5N-11	5838		

STAREX

Starex 2.4	A1	2.4	82	4	06.97-04.04	G4CS	0,8	BPR6ES	7822		LPG 2
Starex		2.4	82	4	02.98-	SOHC	1,1	BP6ES-11	1212		LPG 2
Starex 2.4	A1	2.4	82	4	02.98-08.00	G4CS	0,8	BPR6ES	7822		LPG 2
Starex 2.4	A1	2.4	82	4	02.98-08.00	G4CS	1,1	BPR6ES-11	4824	13	LPG 2
Starex 2.4	A1	2.4	101	4	02.03-04.04	G4JS	1,1	PGR5C-11	5760		
Starex 2.4	TQ	2.4	101	4	02.08-	G4CS	1,1	ILFR5B11	1637		ILFR6B

TERRACAN

Terracan 3.5	NM81	3.5	143	6	10.02-12.07	G6CU	1,1	PFR5N-11	5838		
Terracan 3.5	NM81	3.5	147	6	07.01-10.06	G6CU	1,1	PFR5N-11	5838		

TIBURON

Tiburon 1.6	GK	1.6	77	4	02.02-12.08	G4ED	1,1	BKR5ES-11	2382		LPG 1
Tiburon 1.6 CVVT	GK	1.6	79	4	03.02-12.08	G4ED	1,1	BKR5ES-11	2382		LPG 1
Tiburon		1.6		4	.00-		1,1	BKR5ES-11	2382	33	LPG 1
Tiburon		1.8		4	.00-		1,1	BKR5ES-11	2382	33	LPG 1
Tiburon 2.0 CVVT	GK	2.0	105	4	02.03-12.10	G4GC	1,1	BKR5ES-11	2382		LPG 1





l kW C Y I



Stock-N°

VLINE

LPG/CNG

HYUNDAI

TIBURON

Tiburon		2.0		4	.00-		1,1	BKR5ES-11	2382	33	LPG 1
Tiburon 2.7 CVVT	GK	2.7	121	6	01.03-12.08	G6BA	1,1	IFR5G11	7854		
Tiburon 2.7 CVVT	GK	2.7	123	6	10.04-12.08	G6BA	1,1	IFR5G11	7854		

TRAJET

Trajet / FO		2.0	100	4	05.00-	G4JP-G DOHC	1,1	BPR6ES-11	4824	13	LPG 2
Trajet 2.0	KMJMG8A, KMJMH8A	2.0	103	4	03.01-10.03	G4CP DOHC	1,1	BPR6ES-11	4824	13	LPG 2
Trajet / FO		2.0	103	4	01.04-		1,1	BKR5ES-11	2382	33	LPG 1
Trajet 2.0 CVVT	KMDMF8A, KMDMF8E	2.0	104	4	11.03-07.08	G4GC	1,1	BKR5ES-11	2382		LPG 1
Trajet 2.7 CVVT	KMDMG8A, KMJMF7C	2.7	127	6	02.00-07.08	G6BA	1,1	IFR5G11	7854		
Trajet / FO		2.7	127	6	07.00-	G6BA DOHC	1,1	PFR5N-11	5838		

TUCSON

Tucson 1.6 GDi	TLE	1.6	97	4	06.15-	G4FD	1,0	SILZKR6B10E	93815		
Tucson 2.0 CVVT LPG	JM	2.0	104	4	06.04-03.10	G4GC	0,8	BKR5ES	2460		LPG 1
Tucson 2.0 CVVT	JM	2.0	104	4	06.04-03.10	G4GC	0,8	BKR5ES	2460		LPG 1
Tucson 2.0 CVVT LPG	JM	2.0	104	4	06.04-03.10	G4GC	1,1	BKR5ES-11	2382		LPG 1
Tucson (JM)		2.0	104	4	09.04-	G4GC	1,1	BKR5ES-11	2382	33	LPG 1
Tucson 2.0 CVVT LPG	JM	2.0	104	4	06.09-03.10	G4GC	1,1	BKR5ES-11	2382		LPG 1
Tucson 2.0 CVVT	TLE	2.0	110	4	06.15-	G4NA	1,1	SILZKR7B11	9723		
Tucson 2.0 CVVT	TL, TLE	2.0	114	4	06.15-	G4NA	1,1	SILZKR7B11	9723		
Tucson 2.0 CVVT	LM	2.0	116	4	09.14-06.15	G4NA	1,1	SILZKR7B11	9723		
Tucson 2.4 CVVT	LM	2.4	129	4	08.09-06.15	G4KE	1,1	LFR5A-11	6376		LPG 7
Tucson 2.7 CVVT	JM	2.7	129	6	08.04-11.10	G6BA	1,1	IFR5G11	7854		
Tucson V6 (JM)		2.7	129	6	09.04-	G6BA	1,1	PFR5N-11	5838		

TUSCANI

Tuscani 2.7 -/CVVT	GK	2.7	123	6	10.04-12.08	G6BA	1,1	IFR5G11	7854		
--------------------	----	-----	-----	---	-------------	------	-----	---------	------	--	--

VELOSTER

Veloster 1.6 GDi	FS	1.6	95	4	01.11-12.17	G4FD	1,0	SILZKR6B10E	93815		
Veloster 1.6 MPI	FS	1.6	97	4	02.11-12.17	G4FC	1,0	LZKR6B-10E	1578	49	

VERACRUZ

Veracruz 3.8	SH83S	3.8	191	6	01.07-11.12	G6DA	1,1	IFR5G11	7854		
Veracruz 3.8	SH83S	3.8	194	6	09.06-11.12	G6DA	1,1	IFR5G11	7854		

XG-SERIES

XG 250 V6		2.5	120	6	06.99-09.03	G6AV	1,1	PFR5N-11	5838		
XG250 2.5	XG	2.5	120	6	06.02-09.03	G6BV	1,1	PFR5N-11	5838		
XG250 2.5	XG	2.5	123	6	10.03-09.05	G6AV	1,1	PFR5N-11	5838		
XG 300 V6		3.0	138	6	12.98-	G6CT	1,1	PFR5N-11	5838		
XG300 3.0	XG	3.0	143	6	01.01-09.05	G6CT	1,1	PFR5N-11	5838		
XG 350 V6		3.5	145	6	10.02-09.05	G6CU	1,1	PFR5N-11	5838		

INFINITI

EX SERIES

EX 35	J50	3.5	221	6	10.08-12.10	VQ35HR	1,1	DF7H-11B	1317		
EX37 3.7	J50	3.7	235	6	04.08-	VQ37VHR	1,1	DF7H-11B	1317		
EX 37	J50	3.7	235	6	09.10-	VQ37VHR	1,1	DF8H-11B	1305		
EX37 3.7	J50	3.7	243	6	10.08-	VQ37VHR	1,1	DF7H-11B	1317		





e kW C
Y
I



Stock-N°

VLINE

LPG/CNG

INFINITI

EX SERIES

EX37 3.7	J50	3.7	243	6	10.08-	VQ37VHR	1,1	DF8H-11B	1305		
----------	-----	-----	-----	---	--------	---------	-----	----------	------	--	--

FX SERIES

FX 35	S50	3.5	206	6	.05-	VQ35DE V6	1,1	PLFR5A-11	6240		LPG 7
FX35 3.5	S51	3.5	226	6	09.09-07.13	VQ35HR	1,1	DF7H-11B	1317		
FX 37	S51	3.7	235	6	10.08-	VQ37VHR	1,1	DF8H-11B	1305		
FX37 3.7	S51	3.7	245	6	07.08-07.13	VQ37VHR	1,1	DF8H-11B	1305		
FX 45	S50	4.5	232	8	01.03-12.08	VK45DE	1,1	PLFR5A-11	6240		LPG 7
FX 45	S50	4.5	241	8	11.07-03.09	VK45DE	1,1	PLFR5A-11	6240		LPG 7
FX 50	S51	5.0	287	8	10.08-07.13	VK50VE	1,1	DF7H-11B	1317		
FX50 5.0	S51	5.0	291	8	07.08-07.13	VK50VE	1,1	DF7H-11B	1317		
FX 50	S51	5.0	294	8	07.08-07.13	VK50VE	1,1	DF7H-11B	1317		
FX 50	S51	5.0	309	8	06.13-07.13	VK50VE	1,1	DF7H-11B	1317		

G SERIES

G 20		2.0		4	.91- .94	SR20DE	1,1	PFR5B-11	2300		PFR6B
G 20		2.0		4	.95- .96	SR20DE	1,1	PFR5B-11	2300		PFR6B
G 20		2.0		4	.99-	SR20DE	1,1	PFR5G-11	2647		
G 25	V36	2.5	163	6	01.11-	VQ25HR	1,1	DF7H-11B	1317		
G25 2.5	V36	2.5	163	6	01.11-	VQ25HR	1,1	DF7H-11B	1317		
G 35	V36	3.5	228	6	12.06-12.08	VQ35HR	1,1	DF7H-11B	1317		
G35 3.5	V36	3.5	228	6	01.07-12.08	VQ35HR	1,1	DF7H-11B	1317		
G 37	V36	3.7	235	6	10.08-	VQ37VHR	1,1	DF8H-11B	1305		
G 37	V36	3.7	243	6	10.08-	VQ37VHR	1,1	DF8H-11B	1305		
G37 3.7	CV36	3.7	245	6	09.08-12.13	VQ37VHR	1,1	DF8H-11B	1305		
G37 3.7	V36	3.7	245	6	12.08-	VQ37VHR	1,1	DF8H-11B	1305		

I SERIES

I 30		3.0		6	.96- .99	VQ30DE V6	1,1	PFR5G-11	2647		
------	--	-----	--	---	----------	-----------	-----	----------	------	--	--

J SERIES

J 30		3.0		6	.93- .97	VG30DE V6	1,1	PFR5G-11	2647		
------	--	-----	--	---	----------	-----------	-----	----------	------	--	--

M SERIES

M 30		3.0		6	.90- .92	VG30E	1,1	PFR6B-11	4014		PFR7B
M35 3.5	Y50	3.5	206	6	01.05-12.10	VQ35DE	1,1	PLFR5A-11	6240		LPG 7
M 35 Hybrid	Y51HV	3.5	225	6	04.11-	VQ35HR	1,1	DF7H-11B	1317		
M35 3.5	Y50	3.5	226	6	09.08-12.10	VQ35HR	1,1	DF7H-11B	1317		
M 35 Hybrid	Y51HV	3.5	268	6	01.10-	VQ35HR	1,1	DF7H-11B	1317		
M35h 3.5 Hybrid	Y51HV	3.5	268	6	01.10-	VQ35HR	1,1	DF7H-11B	1317		
M 37	Y51	3.7	235	6	03.10-	VQ37VHR	1,1	DF8H-11B	1305		
M37 3.7	Y51	3.7	243	6	01.10-	VQ37VHR	1,1	DF8H-11B	1305		
M37 3.7	Y51	3.7	246	6	01.10-	VQ37VHR	1,1	DF8H-11B	1305		
M 45	Y50	4.5	250	8	01.05-05.10	VK45DE	1,1	PLFR5A-11	6240		LPG 7
M 56	Y51	5.6	300	8	07.10-	VK56VD	1,1	DILKAR7B11	1406		

Q SERIES

Q50 3.5 Hybrid	V37	3.5	219	6	06.13-	VQ35HR	1,1	DF7H-11B	1317		
Q 70 3.5 Hybrid	Y51	3.5	225	6	03.13-	VQ35HR	1,1	DF7H-11B	1317		
Q 50 3.5 Hybrid	V37	3.5	268	6	04.13-	VQ35HR	1,1	DF7H-11B	1317		
Q70 3.7	Y51	3.7	235	6	09.13-	VQ37VHR	1,1	DF8H-11B	1305		





kw
C
Y
I



Stock-N°

VLINE

LPG/CNG

INFINITI

Q SERIES

Q 60 3.7	CV36, HV36	3.7	235	6	10.13-	VQ37VHR	1,1	DF8H-11B	1305		
Q70 3.7	Y51	3.7	245	6	01.14-	VQ37VHR	1,1	DF8H-11B	1305		
Q 45		4.1		8	.97- .98	VH41DE	1,1	PFR5G-11	2647		
Q 45		4.5		8	.90- .93	VH45D	1,1	PFR5B-11	2300		PFR6B
Q 45		4.5		8	.94- .96	VH45DE	1,1	PFR5G-11	2647		

QX SERIES

QX 50 2.5	J50	2.5	163	6	02.14-	VQ25HR	1,1	DF7H-11B	1317		
QX 4		3.3		6	.97- .98	VG33E	1,1	BKR5ES-11	2382	33	LPG 1
QX 4		3.3		6	.99-	VD33DE	1,0	FR5AP-10	5463		
QX60 3.5	L50	3.5	193	6	10.13-	VQ35DE	1,1	DF7H-11B	1317		
QX 4		3.5		6	.01-	VQ35DE	1,1	PLFR5A-11	6240		LPG 7
QX 50 37		3.7	235	6	08.13-	VQ37VHR	1,1	DF8H-11B	1305		
QX 70 37	S51	3.7	235	6	08.13-	VQ37VHR	1,1	DF8H-11B	1305		
QX70 3.7	S51	3.7	235	6	08.13-	VQ37VHR	1,1	DF8H-11B	1305		
QX50 3.7	J50	3.7	242	6	08.13-	VQ37VHR	1,1	DF8H-11B	1305		
QX 70 50	S51	5.0	287	8	08.13-	VK50VE	1,1	DF7H-11B	1317		
QX 56	Z62	5.6	298	8	03.10-	VK56VD	1,1	DILKAR7B11	1406		
QX 56		5.6		8	.08-	VK56DE FI	1,1	LFR5A-11	6376		LPG 7

INNOCENTI

CLIP IE

Clip ie		1.0	35	4	09.95-06.97	146C7.000	0,9	BPR5ES	7422	6	LPG 2
---------	--	-----	----	---	-------------	-----------	-----	--------	------	---	-------

CLIP IE SUPER

Clip ie Super		1.4	51	4	09.95-06.97	160A1.046	0,8	BPR6ES	7822	2	LPG 2
---------------	--	-----	----	---	-------------	-----------	-----	--------	------	---	-------

ELBA

Elba		1.3	49	4	07.91-08.93	146A5.000	0,8	BPR6ES	7822	2	LPG 2
------	--	-----	----	---	-------------	-----------	-----	--------	------	---	-------

ELBA IE

Elba ie		1.4	49	4	11.95-06.97	146C5.000	0,8	BPR6ES	7822	2	LPG 2
---------	--	-----	----	---	-------------	-----------	-----	--------	------	---	-------

Elba ie		1.6	55	4	11.95-06.97	146C6.000	0,8	BPR6ES	7822	2	LPG 2
---------	--	-----	----	---	-------------	-----------	-----	--------	------	---	-------

ELBA IE HAPPY

Elba ie Happy		1.6	55	4	06.95-06.96	146C6.000	0,8	BPR6ES	7822	2	LPG 2
---------------	--	-----	----	---	-------------	-----------	-----	--------	------	---	-------

KORAL 45

Koral 45		0.9	33	4	10.90-06.97	100GL064	0,8	BPR6ES	7822	2	LPG 2
----------	--	-----	----	---	-------------	----------	-----	--------	------	---	-------

KORAL 55

Koral 55		1.1	41	4	10.90-06.97	128A.064	0,8	BPR6ES	7822	2	LPG 2
----------	--	-----	----	---	-------------	----------	-----	--------	------	---	-------

MILLE

Mille		1.0	35	4	07.94-06.97	146C7.000	0,7	BP6ES	7811	4	LPG 2
-------	--	-----	----	---	-------------	-----------	-----	-------	------	---	-------

MILLE I.

Mille i.		1.0	35	4	07.94-06.97	146C7.000	0,9	BPR5ES	7422	6	LPG 2
----------	--	-----	----	---	-------------	-----------	-----	--------	------	---	-------

SMALL 500 L / LS

Small 500 L / LS		0.6	23	3	01.91-06.97	Daihatsu E	0,9	BPR6EY	6427		LPG 2
------------------	--	-----	----	---	-------------	------------	-----	--------	------	--	-------

SMALL 990 SE

Small 990 SE		1.0	38	3	01.91-06.97	Daihatsu CB	0,8	BPR5EY	2828	9	LPG 2
--------------	--	-----	----	---	-------------	-------------	-----	--------	------	---	-------





e kW C
Y
I



Stock-N°

VLINE

LPG/CNG

ISUZU

BIGHORN

Bighorn 3.5	UBS25	3.5	158	6	08.98-08.04	6VE1	1,1	BKR5EIX-11	5464		LPG 1
-------------	-------	-----	-----	---	-------------	------	-----	------------	------	--	-------

RODEO

Rodeo		3.2	151	6	.98-	V DOHC	1,1	PFR5G-11	2647		
-------	--	-----	-----	---	------	--------	-----	----------	------	--	--

TROOPER

Trooper		2.3	66	4	01.87-	4ZD1 Cat.	1,1	BPR6ES-11	4824	13	LPG 2
Trooper		2.3		4	.87-		0,8	BPR6ES	7822	2	LPG 2
Trooper		2.3		4	.88-	4ZD1	0,8	BPR6ES	7822	2	LPG 2
Trooper 3.5 -/RS	UBS26D, UBS26G	3.5	158	6	08.98-08.04	6VE1	1,1	BKR5EIX-11	5464		LPG 1
Trooper 3.5	UBS26D	3.5	158	6	08.98-08.04	6VE1	1,1	BKR5EIX-11	5464		LPG 1
Trooper		3.5	158	6	04.00-	6VE1 V6	1,1	PFR6B-11	4014		PFR7B

VEHICROSS

Vehicross 3.2 24V		3.2	158	6	03.97-	6VDI	1,1	BKR6E-11	2756	14	LPG 1
-------------------	--	-----	-----	---	--------	------	-----	----------	------	----	-------

JAGUAR

DOUBLE SIX

Double Six		5.3		12	.90-	V 12 HE	0,6	BR7EF	3346		
------------	--	-----	--	----	------	---------	-----	-------	------	--	--

F-TYPE

F-Type Supercharged	X152	3.0	250	6	10.12-	AJ126	0,8	SILZKAR7E8S	93476		
F-Type Supercharged	X152	3.0	280	6	10.12-	AJ126	0,8	SILZKAR7E8S	93476		
F-Type 5.0		5.0	364	8	10.12-	AJ-V8	1,0	ILKAR7C10	94940		

SOVEREIGN

Sovereign 3.2		3.2		6	07.90-07.97	AJ6	0,8	BCPR6ES	2330	12	LPG 3
Sovereign 4.0		4.0		6	09.89-09.97	AJ6	0,8	BCPR6ES	2330	12	LPG 3

SOVEREIGN II

Sovereign 3.2	X308	3.2	179	8	10.97-03.03	AJ32	1,0	IFR5N10	7866		
Sovereign 4.0	X308	4.0	216	8	10.97-04.03	AJ26	1,0	IFR5N10	7866		

S-TYPE (98→)

S-Type 2.5		2.5	143	6	02.01-	AJV6	1,3	TR6AP-13E	4968		LPG 5
S-Type 3.0		3.0	175	6	10.98-	FC AJ-V6	1,3	TR6AP-13E	4968		LPG 5
S-Type V8		4.0	203	8	10.98-03.00	GC AJ-V8	1,3	PFR5G-13E	2761		
S-Type 4.0 (Chassis No →N83878)	X200	4.0	203	8	01.99-04.02	AJ8	1,0	IFR5N10	7866		
S-Type 4.0 (Chassis No N83879→)	X200	4.0	203	8	01.99-04.02	AJ8	1,0	IFR5N10	7866		
S-Type V8		4.0	203	8	03.00-03.02	GC AJ-V8	1,1	PFR5G-11E	3000		
S-Type 4.2 V8		4.2		8	03.02-	AJ-V8	1,0	IFR5N10	7866		
S-Type R		4.2		8	03.02-	AJ28, AJ-V8	1,0	IFR5N10	7866		

VANDEN PLAS

Vanden Plas 4.0 Supercharged	X308	4.0	267	8	10.97-12.03	AJ27S	1,0	IFR5N10	7866		
------------------------------	------	-----	-----	---	-------------	-------	-----	---------	------	--	--

XE SERIE

XE 2.0	X760	2.0	147	4	03.15-	204PT	0,8	ILTR6H8G	96870		
--------	------	-----	-----	---	--------	-------	-----	----------	-------	--	--

XF SERIE

XF 2.0	X250	2.0	177	4	06.12-04.15	204PT	0,8	ILTR6H8G	96870		
XF 3.0	X250	3.0	175	6	03.08-	AJV6	1,3	TR6AP-13E	4968		LPG 5
XF Supercharged	X250	3.0	250	6	03.12-04.15	AJ126	0,8	SILZKAR7E8S	93476		
XF 4.2	X250	4.2	219	8	03.08-	SV82G	1,0	IFR5N10	7866		
XF 4.2 Supercharged	X250	4.2	306	8	03.08-	SV8TS	1,0	IFR5N10	7866		





l kW C
Y
I



Stock-N°

VLINE

LPG/CNG

JAGUAR

XF SERIE

XF 4.2 Supercharged	X250	4.2	313	8	07.09-	SV8TS	1,0	IFR5N10	7866		
XF 5.0	X250	5.0	283	8	03.09-	AJ133	1,0	ILKAR7C10	94940		

XFR SERIE

XFR 5.0 Supercharged	X250	5.0	346	8	01.09-	AJ133	1,0	ILKAR7C10	94940		
XFR 5.0 Supercharged	X250	5.0	375	8	03.09-	AJ133	1,0	ILKAR7C10	94940		
XFR-S 5.0 Supercharged	X250	5.0	405	8	10.12-	AJ133	1,0	ILKAR7C10	94940		

XJ SERIE

XJ 5.0	X351	5.0	283	8	01.10-	AJ133	1,0	ILKAR7C10	94940		
XJ 5.0 Supercharged	X351	5.0	346	8	01.10-	AJ133	1,0	ILKAR7C10	94940		
XJ 5.0 Supercharged	X351	5.0	375	8	01.10-	AJ133	1,0	ILKAR7C10	94940		
XJ Supercharged	X351	3.0	250	6	03.12-	AJ126	0,8	SILZKAR7E8S	93476		
XJ Supercharged	X351	3.0	250	6	10.12-	AJ126	0,8	SILZKAR7E8S	93476		
XJ8 3.2	X308	3.2	174	8	10.97-03.03	AJ32	1,0	IFR5N10	7866		
XJ8 3.2	X308	3.2	179	8	11.97-06.03	AJ32	1,0	IFR5N10	7866		
XJR 4.0 Supercharged	X308	4.0	267	8	10.97-03.03	AJ27S	1,0	IFR5N10	7866		
XJ12		5.3		12	.91- .93	HE(V12)	0,6	BR7EF	3346		
XJ12		6.0		12	.92-11.94	V12	0,6	BR7EF	3346		
XJ12		6.0		12	.93-11.94	HE(V12)	0,6	BR7EF	3346		
XJ12		6.0		12	11.94-09.96	HE(V12), V12	0,6	BR6EF	3177		
XJ6		3.0		6	03.02-	AJ-V6	1,3	PTR6D-13	5598		LPG 5
XJ6 3.0		3.0		6	03.03-	AJ-V6	1,3	TR6AP-13E	4968		LPG 5
XJ6		3.2		6	07.90-07.97	AJ6 Cat., 9BPMNA	0,8	BCPR6ES	2330	12	LPG 3
XJ6		3.6	136	6	08.86-05.92	AJ6, 9DPANA	0,8	BCPR6ES	2330	12	LPG 3
XJ6		4.0		6	09.89-09.97	AJ6 Cat.	0,8	BCPR6ES	2330	12	LPG 3
XJ6 V12		5.3		12	01.91-	V12	0,6	BR7EFS	1094		
XJ8		3.2	174	8	09.97-09.98	V8	1,3	PFR6G-13E	2341		
XJ8		3.2	176	8	09.97-		1,3	PFR6G-13E	2341		
XJ8		3.2		8	09.97-09.98	AJ26	1,3	PFR5G-13E	2761		
XJ8		3.2		8	09.98-03.00	AJ26	1,3	PFR5G-13E	2761		
XJ8		3.2		8	03.00-03.02	AJ26	1,1	PFR5G-11E	3000		
XJ8		3.2		8	03.02-	AJ26	1,0	IFR5N10	7866		
XJ8		3.5	190	8	03.03-06.06	AJ33	1,0	IFR5N10	7866		
XJ8		3.5		8	03.02-	AJ26	1,0	IFR5N10	7866		
XJ8		4.0	209	8	09.97-	V8	1,3	PFR6G-13E	2341		
XJ8		4.0		8	09.97-09.98	AJ26	1,3	PFR5G-13E	2761		
XJ8		4.0		8	09.98-03.00	AJ26	1,3	PFR5G-13E	2761		
XJ8		4.0		8	03.00-03.02	AJ26	1,1	PFR5G-11E	3000		
XJ8		4.0		8	03.02-	AJ26	1,0	IFR5N10	7866		
XJ8		4.2	219	8	03.03-06.06	AJ33	1,0	IFR5N10	7866		
XJ8 Supercharged		4.2	291	8	03.03-09.09	AJ33	1,0	IFR5N10	7866		
XJ8		4.2		8	03.02-	AJ26	1,0	IFR5N10	7866		
XJ8R		4.0	272	8	09.97-03.00		1,3	PFR6G-13E	2341		
XJ8R Supercharged		4.0		8	09.97-02.00	AJ26	1,3	PFR6G-13E	2341		
XJ8R 4.0		4.0		8	03.00-03.02	AJ26	1,1	PFR5G-11E	3000		
XJ8R		4.0		8	03.02-	AJ26	1,0	IFR5N10	7866		





e kW C
Y
I



Stock-N°

VLINE

LPG/CNG

JAGUAR

XJ SERIE

XJ8R 4.2	4.2		8	03.02-		1,0	IFR5N10	7866		
XJR Supercharged X300	4.0	235	6	08.94-08.97	AJ16 Kompressor	0,9	BKR7E	6097		BKR8EIX
XJR 4.0	4.0		6	09.89-09.94	AJ6	0,8	BCPR6ES	2330	12	LPG 3
XJR V8 (X300)	4.0	267	8	09.97-02.00	AJ26	1,3	PFR6G-13E	2341		
XJS 3.6	3.6		6	09.75-	9DPANA	0,8	BCPR6ES	2330	12	LPG 3
XJS 3.6	3.6		6	08.86-05.91	AJ6	0,8	BCPR6ES	2330	12	LPG 3
XJS Coupe	4.0		6	04.91-09.96	AJ6	0,8	BCPR6ES	2330	12	LPG 3
XJS	5.3		12	.91- .93	V12 HE	0,6	BR7EF	3346		
XJS V12	6.0		12	05.93-11.94	V12	0,6	BR7EF	3346		
XJS V12	6.0		12	11.94-05.95	V12	0,6	BR6EF	3177		

XK SERIE

XK8 4.0 (Chassis No →018107)	X100	4.0	209	8	03.96-10.02	AJEE	1,3	PFR6G-13E	2341	
XK8		4.0	213	8	10.96-09.97	AJ, V8	1,1	PFR6G-13E	2341	
XK8		4.0	213	8	09.97-09.98	AJ26	1,3	PFR5G-13E	2761	
XK8 4.0 (Chassis No 018108→031302)	X100	4.0	216	8	05.96-07.99	AJCE	1,0	IFR5N10	7866	
XK8 4.0 (Chassis No 031303→)	X100	4.0	216	8	05.96-07.99	AJCE	1,0	IFR5N10	7866	
XK8 4.0 (Chassis No 031308→)	X100	4.0	216	8	05.96-07.99	AJCE	1,0	IFR5N10	7866	
XK8 4.0 (Chassis No →018107)	X100	4.0	216	8	05.96-07.99	AJCE	1,3	PFR6G-13E	2341	
XK8		4.0	389	8	10.96-09.97	AJ26	1,1	PFR6G-13E	2341	
XK8		4.0		8	09.97-09.98	AJ27	1,3	PFR5G-13E	2761	
XK8		4.0		8	09.98-03.00	AJ26, AJ27	1,3	PFR5G-13E	2761	
XK8		4.0		8	03.00-	AJ26	1,1	PFR5G-11E	3000	
XK8		4.0		8	03.00-02.02	AJ27	1,1	PFR5G-11E	3000	
XK8		4.0		8	03.02-	AJ27	1,0	IFR5N10	7866	
XK8		4.2		8	09.02-	AJ34	1,0	IFR5N10	7866	
XK8 5.0		5.0	283	8	01.09-	AJ133	1,0	ILKAR7C10	94940	
XKR 4.0 Supercharged	X100	4.0	267	8	02.98-10.02	AJCK, AJED, AJEP	1,0	IFR5N10	7866	
XKR 4.0 Supercharged	X100	4.0	267	8	02.98-10.02	AJCK, AJED, AJEP	1,3	PFR6G-13E	2341	
XKR		4.0	267	8	05.98-03.00	AJ27	1,3	PFR6G-13E	2341	
XKR		4.0	267	8	03.00-02.02	AJ27	1,1	PFR5G-11E	3000	
XKR 4.0 Supercharged (Chassis No A00116→)	X100	4.0	276	8	05.98-05.07	AJCK, AJED, AJEP	1,0	IFR5N10	7866	
XKR 4.0 Supercharged (Chassis No →A00115)	X100	4.0	276	8	05.98-05.07	AJCK, AJED, AJEP	1,3	PFR6G-13E	2341	
XKR		4.0		8	03.02-	AJ27	1,0	IFR5N10	7866	
XKR		4.2		8	09.02-	AJ34	1,0	IFR5N10	7866	
XKR 5.0 Supercharged		5.0	375	8	01.09-	AJ133	1,0	ILKAR7C10	94940	
XKR 5.0 Supercharged		5.0	390	8	09.10-	AJ133	1,0	ILKAR7C10	94940	
XKR-S 5.0 Supercharged		5.0	405	8	01.11-	AJ133	1,0	ILKAR7C10	94940	

X-TYPE

X-Type 2.0	2.0	117	6	12.01-	AJ-V6	1,3	TR6AP-13E	4968		LPG 5
X-Type 2.5	2.5	140	6	02.01-	AJ-V6	1,3	TR6AP-13E	4968		LPG 5
X-Type 3.0	3.0	173	6	02.01-	AJ-V6	1,3	TR6AP-13E	4968		LPG 5

JEEP

CHEROKEE

JEEP Cherokee 2.4 MultiAir	KL	2.4	130	4	11.13-	ED6, EDD	1,1	LZFR5CI-11	92145	
----------------------------	----	-----	-----	---	--------	----------	-----	------------	-------	--





kw
C
Y
I



Stock-N°

VLINE

LPG/CNG

JEEP

CHEROKEE

JEEP Cherokee 2.4 MultiAir	KL	2.4	137	4	06.13-08.18	ED6	1,1	LZFR5CI-11	92145		
Cherokee		2.5		4	.90- .98	L4 MPI P	0,9	FR5-1	7252		

CHEROKEE (KJ)

Cherokee 2.4 (KJ)		2.4	108	4	08.01-	ED1	1,1	LZTR4A-11	5444		
Cherokee 3.7 V6 (KJ)		3.7	155	6	10.01-	EKG	1,1	ZFR5F-11	2262	40	LPG6

COMMANCHE

Comanche		2.5		4	.91- .92	L4 MPI P	0,9	FR5-1	7252		
Comanche		4.0		6	.91- .92	L6 MPI S	0,9	FR5-1	7252		

COMMANDER

JEEP Commander 5.7 HEMI	XH	5.7	240	8	01.09-12.10	EZB	1,1	LZFR5CI-11	92145		
JEEP Commander 5.7 HEMI	XH	5.7	255	8	06.09-12.10	EZH	1,1	LZFR5CI-11	92145		

GRAND CHEROKEE

Grand Cherokee		3.7		6	.05-	V6 K FI	1,1	PZFR6F-11	3271		LPG 6
Grand Cherokee		4.0		6	.91- .98	L6 S MPI	0,9	FR5-1	7252		
Grand Cherokee		4.0		6	.03- .04	L6 S FI	0,8	ZFR5N	7917		
Grand Cherokee		4.7	173	8	02.99- .99	V8 N MPI	1,1	PZFR6F-11	3271		LPG 6
Grand Cherokee		4.7		8	.00- .04	V8 N FI SOHC	1,1	PZFR6F-11	3271		LPG 6
Grand Cherokee		4.7		8	.02- .04	V8 J FI SOHC&H.O.	0,9	BKR7E	6097		BKR8EIX
Grand Cherokee		4.7		8	.05-	V8 N FI	1,1	PZFR6F-11	3271		LPG 6
Grand Cherokee		5.2		8	.93- .96	V8 Y MPI	0,9	FR4	5155		
Grand Cherokee		5.2		8	.97- .98	V8 Y MPI	0,9	FR5-1	7252		
Grand Cherokee		5.7	240	8	.05-	V8 2 FI	1,1	LZTR4A-11	5444		
JEEP Grand Cherokee 5.7 HEMI	WH	5.7	259	8	01.09-12.10	EZD	1,1	LZFR5CI-11	92145		
JEEP Grand Cherokee 5.7 HEMI	WK2	5.7	259	8	11.10-	EZH	1,1	LZFR5CI-11	92145		
JEEP Grand Cherokee 5.7 HEMI	WK	5.7	265	8	01.09-05.10	EZD	1,1	LZFR5CI-11	92145		
JEEP Grand Cherokee 5.7 HEMI	WK2	5.7	268	8	01.14-	EZH	1,1	LZFR5CI-11	92145		
Grand Cherokee		5.9		8	.98-	V8 MPI Z	1,0	FR5-1	7252		
Grand Cherokee SRT-8		6.1	313	8	08.06-		1,3	PLZTR5A-13	4998		

GRAND WAGONEER

Grand Wagoneer		5.2		8	.93- .93	V8 MPI Y	0,9	FR4	5155		
Grand Wagoneer		5.9		8	.89- .91	V8 2Bbl 7	0,9	GR4	2635		GR5IX
Grand Wagoneer		5.9		8	.97-	V8 MPI Z	0,9	FR4	5155		

LIBERTY

Liberty		2.4		4	.02-	L4 1 FI	1,1	LZTR4A-11	5444		
Liberty		3.7		6	.02-	V6 K FI	1,1	PZFR6F-11	3271		LPG 6

MK 49

Compass 2.0		2.0	115	4	05.11-	ECN	1,1	ZFR5F-11	2262	40	LPG6
Compass 2.4		2.4	125	4	08.06-	ED3, EDG	1,1	ZFR5F-11	2262	40	LPG6

RENEGADE

Renegade 1.6 E-torQ	BU	1.6	81	4	07.14-	EJH(55263842)	1,0	ZKR7BI-10	95536		
---------------------	----	-----	----	---	--------	---------------	-----	-----------	-------	--	--

WAGONEER

Wagoneer		2.5		4	.91- .92	L4 MPI P	0,9	FR5-1	7252		
Wagoneer		4.0		6	.91- .92	L6 MPI S	0,9	FR5-1	7252		





l kW C
Y I



Stock-Nº

VLINE

LPG/CNG

JEEP

WRANGLER

Wrangler	2.5		4	.91-01.01	L4 MPI P	0,9	FR5-1	7252		
Wrangler Rubicon 3.8	3.8	146	6	.07-	V6 FI	1,3	LZTR5A-13	4612		
Wrangler Unlimited	3.8	151	6	.07-		1,3	LZTR5A-13	4612		
Wrangler	4.0	135	6	.91-	L6 MPI	1,1	ZFR5A-11	5084		LPG 6
Wrangler	4.0		6	.91- .95	L6 MPI S	0,9	FR5-1	7252		
Wrangler	4.0		6	.96- .97	L6 MPI V	0,9	FR5-1	7252		
Wrangler	4.0		6	.98- .02	L6 MPI S	0,9	FR5-1	7252		

KIA

CARENS

Carens 1.6	1.6	77	4	06.02-	S6D	1,1	BKR6ES-11	5553	14	LPG 1
Carens 1.8	1.8	81	4	.01-		0,9	BKR6E	6962	28	LPG 1
Carens 1.8	1.8	93	4	06.02-	TB	0,8	BKR6ES	3783	28	LPG 1

CARENS II

Carens II 2.0	2.0	102	4	08.04-	G4GC	1,1	BKR5ES-11	2382	33	LPG 1
---------------	-----	-----	---	--------	------	-----	-----------	------	----	-------

CARENS III

Carens III 1.6 CVT	1.6	93	4	06.09-	G4FC	1,0	LZKR6B-10E	1578	49	
Carens III 1.6 CVT	1.6	97	4	08.09-	G4FC	1,0	LZKR6B-10E	1578	49	
Carens III	2.0	106	4	09.06-	G4KA	1,1	BKR5ES-11	2382	33	LPG 1

CARENS IV

Carens IV 1.6	1.6	99	4	03.13-	G4FD	1,0	SILZKR6B10E	93815		
Carens IV 2.0 GDI	2.0	122	4	03.13-	G4NC	1,1	SILZKR7B11	9723		

CARNIVAL

Carnival 2.5	2.5	121	6	12.98- .01	K5	1,1	PFR6N-11	3546		LPG 1
Carnival 2.5	2.5	129	6	12.98- .01	KV5 DOHC	1,1	PFR6N-11	3546		LPG 1

CARNIVAL II

Carnival II 2.5	2.5	110	6	10.01-		1,1	PFR6N-11	3546		LPG 1
Carnival II 2.7	2.7	139	6	06.06-	G6EA V6	1,1	ILFR5B11	1637		ILFR6B

CEE D (CD)

Ceed 1.0 T-GDi	CD	1.0	74	3	09.19-	G3LC	0,7	ILKR9Q7G	97312		
Ceed 1.0 T-GDi	CD	1.0	88	3	03.18-	G3LC	0,7	ILKR9Q7G	97312		
Ceed 1.4 LPG	CD	1.4	71	4	12.18-	G4LC	1,0	SILKR6C10E	97098		
Ceed 1.4 MPi	CD	1.4	73	4	03.18-	G4LC	1,0	SILKR6C10E	97098		
Ceed 1.4 MPi	CD	1.4	73	4	04.18-	G4LC	1,0	SILKR6C10E	97098		
Ceed 1.4 T-GDi	CD	1.4	103	4	03.18-	G4LD	0,7	ILKR9Q7G	97312		
Ceed 1.6 MPi	CD	1.6	94	4	03.18-	G4FG	1,0	LZKR6B-10E	1578	49	
Ceed 1.6 MPi	CD	1.6	94	4	05.18-	G4FG	1,0	LZKR6B-10E	1578	49	

CEE D (ED)

Ceed 1.4 CVT BiFuel	ED	1.4	64	4	06.11-04.12	G4FA	1,0	LZKR6B-10E	1578	49	
Ceed 1.4 (ED)		1.4	66	4	07.09-	G4FA	1,0	LZKR6B-10E	1578	49	
Ceed 1.4 CVT	ED	1.4	77	4	11.06-11.08	G4FA	1,1	ZFR5F-11	2262	40	LPG6
Ceed 1.4 CVT	ED	1.4	77	4	12.08-02.09	G4FA	1,0	LZKR6B-10E	1578	49	
Ceed 1.4 CVT	ED	1.4	77	4	05.09-12.12	G4FA	1,0	LZKR6B-10E	1578	49	
Ceed 1.4 CVT	ED	1.4	77	4	10.10-12.12	G4FA	1,0	LZKR6B-10E	1578	49	
Ceed 1.4 (ED)		1.4	80	4	01.07-12.08	G4FA	1,1	ZFR5F-11	2262	40	LPG6
Ceed 1.4 (ED)		1.4	80	4	01.09-	G4FA	1,0	LZKR6B-10E	1578	49	





l kW C
Y
I



Stock-N^o

VLINE

LPG/CNG

KIA

CEE D (ED)

Ceed 1.4 CVVT BiFuel	ED	1.4	80	4	01.09-02.09	G4FA	1,0	LZKR6B-10E	1578	49	
Ceed 1.4 CVVT BiFuel	ED	1.4	80	4	05.09-12.10	G4FA	1,0	LZKR6B-10E	1578	49	
Ceed 1.6 (ED)		1.6	85	4	09.07-	G4FC	1,0	LZKR6B-10E	1578	49	
Ceed 1.6 CVVT	ED	1.6	85	4	09.07-12.08	G4FC	1,1	ZFR5F-11	2262	40	LPG6
Ceed 1.6 CVVT	ED	1.6	85	4	02.08-12.08	G4FC	1,1	ZFR5F-11	2262	40	LPG6
Ceed 1.6 CVVT	ED	1.6	85	4	01.09-02.09	G4FC	1,0	LZKR6B-10E	1578	49	
Ceed 1.6 CVVT	ED	1.6	85	4	05.09-12.12	G4FC	1,0	LZKR6B-10E	1578	49	
Ceed 1.6 CVVT BiFuel	ED	1.6	87	4	06.11-12.11	G4FC	1,0	LZKR6B-10E	1578	49	
Ceed 1.6 (ED)		1.6	90	4	12.06-12.08	G4FC	1,1	ZFR5F-11	2262	40	LPG6
Ceed 1.6 (ED)		1.6	90	4	01.09-	G4FC	1,0	LZKR6B-10E	1578	49	
Ceed 1.6 CVVT BiFuel	ED	1.6	91	4	06.07-03.09	G4FC	1,1	ZFR5F-11	2262	40	LPG6
Ceed 1.6 CVVT BiFuel	ED	1.6	91	4	01.08-12.11	G4FC	1,0	LZKR6B-10E	1578	49	
Ceed 1.6 CVVT BiFuel	ED	1.6	91	4	04.09-05.09	G4FC	1,0	LZKR6B-10E	1578	49	
Ceed 1.6 CVVT BiFuel	ED	1.6	91	4	06.09-12.11	G4FC	1,0	LZKR6B-10E	1578	49	
Ceed 1.6 CVVT (ED)		1.6	92	4	10.10-	G4FC	1,0	LZKR6B-10E	1578	49	
Ceed 1.6 (ED)		1.6	93	4	09.07-12.08	G4FC	1,1	ZFR5F-11	2262	40	LPG6
Ceed 1.6 (ED)		1.6	93	4	01.09-	G4FC	1,0	LZKR6B-10E	1578	49	
Ceed 2.0 (ED)		2.0	105	4	01.07-	G4GC	0,8	BKR5ES-11	2382	33	LPG 1

CEE D (JD)

Ceed 1.0 T-GDi	JD	1.0	74	3	04.15-	G3LC	0,7	ILKR9Q7G	97312		
Ceed 1.0 T-GDi	JD	1.0	88	3	04.15-	G3LC	0,7	ILKR9Q7G	97312		
Ceed 1.4 CVVT (For cold climate zones)	JD	1.4	66	4	05.12-	G4FA	1,0	LZKR6B-10E	1578	49	
Ceed 1.4 CVVT (Not for cold climate zones)	JD	1.4	66	4	05.12-	G4FA	1,0	LZKR6B-10E	1578	49	
Ceed 1.4 CVVT BiFuel (For cold climate zones)	JD	1.4	72	4	01.13-	G4FA	1,0	LZKR6B-10E	1578	49	
Ceed 1.4 CVVT BiFuel (Not for cold climate zones)	JD	1.4	72	4	01.13-	G4FA	1,0	LZKR6B-10E	1578	49	
Ceed 1.4 CVVT (For cold climate zones)	JD	1.4	73	4	05.12-	G4FA	1,0	LZKR6B-10E	1578	49	
Ceed 1.4 CVVT (Not for cold climate zones)	JD	1.4	73	4	05.12-	G4FA	1,0	LZKR6B-10E	1578	49	
Ceed 1.4 CVVT (For cold climate zones)	JD	1.4	73	4	09.12-	G4FA	1,0	LZKR6B-10E	1578	49	
Ceed 1.4 CVVT (Not for cold climate zones)	JD	1.4	73	4	09.12-	G4FA	1,0	LZKR6B-10E	1578	49	
Ceed 1.4 CVVT	JD	1.4	73	4	04.15-	G4FA	1,0	LZKR6B-10E	1578	49	
Ceed (JD) 1.4 CVVT		1.4	74	4	04.15-	G4LC	1,0	SILKR6C10E	97098		
Ceed 1.6 CVVT	JD	1.6	95	4	01.13-	G4FC	1,0	LZKR6B-10E	1578	49	
Ceed 1.6 CVVT	JD	1.6	95	4	11.14-	G4FC	1,0	LZKR6B-10E	1578	49	
Ceed 1.6 CVVT	JD	1.6	96	4	11.14-	G4FC	1,0	LZKR6B-10E	1578	49	
Ceed 1.6 GDi (JD)		1.6	99	4	05.12-	G4FD	1,0	SILZKR6B10E	93815		
Ceed 1.6 GDi	JD	1.6	99	4	04.15-	G4FD	1,0	SILZKR6B10E	93815		

CERATO

Cerato 1.6		1.6	77	4	05.04-	G4ED	1,1	BKR5ES-11	2382	33	LPG 1
Cerato 1.6		1.6	90	4	05.06-	G4FC	1,1	ZFR5F-11	2262	40	LPG6
Cerato 1.6	LD	1.6	90	4	05.06-01.07	G4GR	1,1	ZFR5F-11	2262	40	LPG6
Cerato 2.0		2.0	106	4	05.04-	G4GC	1,1	BKR5ES-11	2382	33	LPG 1

CERATO II

Cerato 1.6 CVVT	TD	1.6	91	4	06.09-	G4FC	1,0	LZKR6B-10E	1578	49	
Cerato 1.6 CVVT	TD	1.6	93	4	09.09-06.13	G4FC	1,0	LZKR6B-10E	1578	49	



e kW C
Y
I

Stock-N°

VLINE

LPG/CNG

KIA**CERATO II**

Cerato Koup 1.6 CVVT	TD	1.6	93	4	01.10-06.13	G4FC	1,0	LZKR6B-10E	1578	49	
Cerato 2.0 CVVT	TD	2.0	110	4	07.09-06.13	G4KD	1,1	LFR5A-11	6376		LPG 7
Cerato Koup 2.0 CVVT	TD	2.0	115	4	06.09-12.13	G4KD	1,1	LFR5A-11	6376		LPG 7
Cerato 2.0 CVVT	TD	2.0	115	4	03.10-06.13	G4KD	1,1	LFR5A-11	6376		LPG 7

CERATO III

Cerato 1.6 MPI	YD	1.6	96	4	06.13-	G4FG	1,0	LZKR6B-10E	1578	49	
Cerato 2.0 CVVT	YD	2.0	110	4	06.13-	G4KD	1,1	SILZKR7B11	9723		
Cerato 2.0 D-CVVT	YD	2.0	112	4	08.16-	G4NA	1,1	SILZKR7B11	9723		

CLARUS

Clarus 1.8		1.8	85	4	06.96- .01	T8 DOHC	0,8	BKR5E	7938	35	LPG 1
Clarus 2.0		2.0	98	4	09.96- .01	FE DOHC	1,1	BK6E-11	7340		LPG 1

FORTE

Forte 2.0 CVVT	K5A	2.0	115	4	08.09-06.13	G4KD	1,1	LFR5A-11	6376		LPG 7
----------------	-----	-----	-----	---	-------------	------	-----	----------	------	--	-------

JOICE

Joice		2.0	103	4	09.01- .03	G4CP	1,1	BPR6ES-11	4824	13	LPG 2
-------	--	-----	-----	---	------------	------	-----	-----------	------	----	-------

MAGENTIS

Magentis 2.0	GD	2.0	100	4	05.01-09.05	G4JP	1,1	BPR6ES-11	4824	13	LPG 2
Magentis		2.0	100	4	.01- .05		0,8	BPR6ES	7822	2	LPG 2
Magentis		2.0	106	4	.06- .09	G4KA	1,1	BKR5ES-11	2382	33	LPG 1
Magentis 2.0 (MG)	MG	2.0	121	4	07.09-	G4KD	1,1	LFR5A-11	6376		LPG 7
Magentis V6		2.5	118	6	.01-	G6BV	0,8	BKR5ES	2460	35	LPG 1
Magentis V6		2.5	124	6	.03-	G6BV	0,8	BKR5ES	2460	35	LPG 1
Magentis V6		2.7	138	6	.06- .09	G6EA	1,1	ILFR5B11	1637		ILFR6B
Magentis 2.7	MG	2.7	142	6	07.09-12.10	G6EA	1,1	ILFR5B11	1637		ILFR6B

MENTOR

Mentor		1.5		4	- .00	B5	1,1	BPR5ES-11	4424		LPG 2
Mentor		1.6		4	06.94-12.00		1,1	BPR5ES-11	4424		LPG 2
Mentor		1.6		4	.01-	A6	0,9	BKR6E	6962	28	LPG 1

OPIRUS

Opirus		3.8		6	.07-	G6DA	1,1	IFR5G11	7854		
--------	--	-----	--	---	------	------	-----	---------	------	--	--

OPIRUS GH

Opirus GH		3.5	149	6	.03- .06		1,1	PFR5N-11	5838		
-----------	--	-----	-----	---	----------	--	-----	----------	------	--	--

OPTIMA

Optima 2.0	MS	2.0	100	4	05.01-09.05	G4JP	1,1	BPR6ES-11	4824	13	LPG 2
Optima 2.0 CVVT	TF	2.0	110	4	01.11-12.15	G4KD	1,1	LFR5A-11	6376		LPG 7
Optima 2.0 Hybrid	TF	2.0	110	4	03.12-	G4KD	1,1	SILZKR7B11	9723		
Optima 2.0 CVVL	JF	2.0	110	4	09.15-	G4ND	1,1	SILZKR7B11	9723		
Optima 2.0	TF	2.0	120	4	03.12-	G4KD	1,1	SILZKR7B11	9723		
Optima 2.0 CVVL/MPI	JF	2.0	120	4	09.15-	G4NA, G4ND	1,1	SILZKR7B11	9723		
Optima 2.0 CVVT	TF	2.0	121	4	03.12-12.15	G4KD	1,1	LFR5A-11	6376		LPG 7
Optima 2.0 CVVT	TF	2.0	121	4	03.13-12.15	G4NA	1,1	SILZKR7B11	9723		
Optima 2.0	TF	2.0	125	4	03.12-	G4KD	1,1	SILZKR7B11	9723		
Optima 2.0 CVVT	TF	2.0	125	4	03.12-12.15	G4KD	1,1	LFR5A-11	6376		LPG 7
Optima 2.4 MPI	JF	2.4	126	4	09.15-	G4KE	1,1	LFR5A-11	6376		LPG 7
Optima 2.4 CVVT	TF	2.4	132	4	01.12-12.15	G4KE	1,1	LFR5A-11	6376		LPG 7





kw
C
Y
I



Stock-N^o

VLINE

LPG/CNG

KIA

PICANTO

Picanto 1.0	BA	1.0	45	4	05.04-	G4HE	1,1	BKR5ES-11	2382	33	LPG 1
Picanto 1.0 BiFuel	SA	1.0	45	4	01.09-04.11	G4HE	1,1	BKR5ES-11	2382		LPG 1
Picanto 1.0	BA	1.0	46	4	11.09-	G4HE	1,1	BKR5ES-11	2382	33	LPG 1
Picanto 1.0 LPG	JA	1.0	48	3	11.18-	G3LA	1,0	SILKR6C10E	97098		
Picanto 1.0 CVVT	TA, JA	1.0	49	3	04.15-	G3LA	1,0	SILKR6C10E	97098		
Picanto 1.0	TA	1.0	51	3	05.11-	G3LA	1,0	LKR6D-10E	96569		
Picanto 1.0 CVVT	JA	1.0	51	3	03.17-	G3LA	1,0	SILKR6C10E	97098		
Picanto 1.0 T-GDi	JA	1.0	74	3	03.17-	G3LC	0,7	ILKR9Q7G	97312		
Picanto 1.1	BA	1.1	48	4	10.03-	G4HG	1,1	BKR5ES-11	2382	33	LPG 1
Picanto 1.1 BiFuel	SA	1.1	48	4	01.09-04.11	G4HG	1,1	BKR5ES-11	2382		LPG 1
Picanto 1.2	TA	1.2	60	4	09.11-	G4LA	1,0	LKR6D-10E	96569		
Picanto 1.2 CVVT	JA	1.2	62	4	03.17-	G4LA	1,0	SILKR6C10E	97098		
Picanto 1.2 CVVT	TA	1.2	64	4	09.11-06.15	G4LA	1,0	LKR6D-10E	96569		
Picanto 1.2 CVVT	TA	1.2	64	4	07.15-02.17	G4LA	1,0	SILKR6C10E	97098		

PRIDE

Pride		1.3	44	4	05.95- .01		1,1	BPR5ES-11	4424		LPG 2
Pride		1.3	53	4	05.95- .01		1,1	BPR5ES-11	4424		LPG 2

PROCEED (CD)

Proceed 1.0 T-GDi	CD	1.0	88	3	10.18-	G3LC	0,7	ILKR9Q7G	97312		
Proceed 1.4 T-GDi	CD	1.4	103	4	10.18-	G4LD	0,7	ILKR9Q7G	97312		

PROCEED (ED)

Proceed 1.4 CVVT	ED	1.4	66	4	12.07-09.12	G4FA	1,0	LZKR6B-10E	1578	49	
Proceed 1.4 CVVT	ED	1.4	77	4	02.08-12.08	G4FA	1,1	ZFR5F-11	2262	40	LPG6
Proceed 1.4 CVVT	ED	1.4	77	4	01.09-02.09	G4FA	1,0	LZKR6B-10E	1578	49	
Proceed 1.4 CVVT	ED	1.4	77	4	05.09-09.12	G4FA	1,0	LZKR6B-10E	1578	49	
Proceed 1.6 CVVT	ED	1.6	85	4	02.08-12.08	G4FC	1,1	ZFR5F-11	2262	40	LPG6
Proceed 1.6 CVVT	ED	1.6	85	4	01.09-02.09	G4FC	1,0	LZKR6B-10E	1578	49	
Proceed 1.6 CVVT	ED	1.6	85	4	05.09-09.12	G4FC	1,0	LZKR6B-10E	1578	49	
Proceed 1.6 CVVT	ED	1.6	92	4	10.10-02.13	G4FC	1,0	LZKR6B-10E	1578	49	

PROCEED (JD)

Proceed 1.0 T-GDi	JD	1.0	74	3	07.15-	G3LC	0,7	ILKR9Q7G	97312		
Proceed 1.0 T-GDi	JD	1.0	88	3	07.15-	G3LC	0,7	ILKR9Q7G	97312		
Proceed 1.4 CVVT	JD	1.4	73	4	05.12-	G4FA	1,0	LZKR6B-10E	1578	49	
Proceed 1.4 CVVT (For cold climate zones)	JD	1.4	73	4	03.13-	G4FA	1,0	LZKR6B-10E	1578	49	
Proceed 1.4 CVVT (Not for cold climate zones)	JD	1.4	73	4	03.13-	G4FA	1,0	LZKR6B-10E	1578	49	
Proceed 1.4 CVVT	JD	1.4	73	4	07.13-	G4LC	1,0	SILKR6C10E	97098		
Proceed 1.4 CVVT (For cold climate zones)	JD	1.4	74	4	07.13-	G4FA	1,0	LZKR6B-10E	1578	49	
Proceed 1.4 CVVT (Not for cold climate zones)	JD	1.4	74	4	07.13-	G4FA	1,0	LZKR6B-10E	1578	49	
Proceed 1.4 CVVT	JD	1.4	74	4	04.15-	G4LC	1,0	SILKR6C10E	97098		
Proceed 1.6 CVVT	JD	1.6	95	4	01.13-	G4FC	1,0	LZKR6B-10E	1578	49	
Proceed 1.6 GDi	JD	1.6	99	4	04.15-	G4FD	1,0	SILZKR6B10E	93815		

QUORIS

Quoris 3.8	KH	3.8	213	6	01.13-	G6DK	1,1	DILKR6A11	97319		
Quoris 3.8	KH	3.8	216	6	05.12-	G6DK	1,1	DILKR6A11	97319		





l kW C
Y
I



Stock-N°

VLINE

LPG/CNG

KIA

RETONA

Retona 16V	2.0	94	4	.00-	FED	1,1	BKR6E-11	2756	14	LPG 1
------------	-----	----	---	------	-----	-----	----------	------	----	-------

RIO I

Rio I 1.3	1.3	55	4	09.00-02.05	B355	1,1	BPR5EY-11	3028		LPG 2
Rio 1.3 BC	1.3	55	4	08.02-02.05	A3E	1,1	BPR5ES-11	4424		LPG 2
Rio 1.3 BC	1.3	60	4	08.00-10.05	A3E	1,1	BPR5ES-11	4424		LPG 2
Rio I 1.3	1.3	60	4	08.02-02.05	KZ301	1,1	BPR5ES-11	4424		LPG 2
Rio 1.5 BC	1.5	70	4	07.00-02.05	A5D	0,9	BKR6E	6962	28	LPG 1
Rio I 1.5	1.5	71	4	09.02-02.05	B571	1,1	BKR6ES-11	5553	14	LPG 1
Rio I 1.5 16V	1.5	72	4	09.00-02.05	B571	0,9	BKR6E	6962	28	LPG 1
Rio 1.5 BC	1.5	72	4	08.02-02.05	A5D	1,1	BKR6ES-11	5553		LPG 1

RIO II

Rio 1.4 JB	1.4	55	4	01.10-12.11	G4EE	1,1	BKR5ES-11	2382		LPG 1
Rio II 1.4 16V	1.4	71	4	06.05-	G4EE	1,1	BKR5ES-11	2382	33	LPG 1
Rio II 1.6 CVVT	1.6	82	4	06.05-	G4ED	1,1	BKR5ES-11	2382	33	LPG 1

RIO III

Rio 1.2 CVVT UB	1.2	51	4	09.11-12.17	G4LA	1,0	LKR6D-10E	96569		
Rio 1.2 LPG UB	1.2	61	4	09.11-	G4LA	1,0	LKR6D-10E	96569		
Rio III 1.2 CVVT UB	1.2	62	4	09.11-	G4LA	1,0	SILKR6C10E	97098		
Rio 1.2 CVVT (For cold climate zones) UB	1.2	62	4	09.11-12.17	G4LA	1,0	LKR6D-10E	96569		
Rio 1.2 CVVT (For cold climate zones) UB	1.2	63	4	10.11-12.17	G4LA	1,0	LKR6D-10E	96569		
Rio 1.2 CVVT UB	1.2	63	4	04.15-12.17	G4LA	1,0	SILKR6C10E	97098		
Rio 1.2 CVVT UB	1.2	64	4	11.14-12.17	G4LA	1,0	LKR6D-10E	96569		
Rio 1.2 CVVT UB	1.2	65	4	06.11-12.17	G4LA	1,0	LKR6D-10E	96569		
Rio 1.2 CVVT UB	1.2	65	4	06.11-12.17	G4LA	1,0	SILKR6C10E	97098		
Rio III 1.25 CVVT UB	1.3	63	4	06.11-	G4LA	1,0	LKR6D-10E	96569		
Rio 1.4 CVVT QBR, UB	1.4	79	4	06.11-03.15	G4FA	1,0	LZKR6B-10E	1578	49	
Rio 1.4 CVVT QBR, UB	1.4	79	4	06.11-	G4FA	1,0	LZKR6B-10E	1578	49	
Rio 1.4 CVVT QBR, UB	1.4	79	4	06.11-	G4FA	1,0	SILZKR6B10E	93815		
Rio III 1.4 CVVT UB	1.4	79	4	09.11-	G4FA	1,0	SILZKR6B10E	93815		
Rio 1.4 CVVT UB	1.4	79	4	09.11-	G4FA	1,0	LZKR6B-10E	1578	49	
Rio III 1.4 CVVT UB	1.4	80	4	06.11-	G4FA	1,0	LZKR6B-10E	1578	49	
Rio 1.4 CVVT QBR, UB	1.4	80	4	09.11-	G4FA	1,0	LZKR6B-10E	1578	49	
Rio 1.4 CVVT UB	1.4	80	4	04.15-	G4FA	1,0	SILZKR6B10E	93815		

RIO IV

Rio IV 1.0 T-GDi YB	1.0	74	3	01.17-	G3LC, G3LE	0,7	ILKR9Q7G	97312		
Rio IV 1.0 T-GDi YB	1.0	88	3	01.17-	G3LC	0,7	ILKR9Q7G	97312		
Rio IV 1.2 CVVT YB	1.2	62	4	01.17-	G4LB	1,0	SILKR6C10E	97098		
Rio IV 1.4 CVVT FB, YB	1.4	73	4	01.17-	G4LC	1,0	SILKR6C10E	97098		
Rio 1.4 CVVT FB	1.4	73	4	07.17-	G4LC	1,0	SILKR6C10E	97098		
Rio 1.4 CVVT YB	1.4	74	4	01.17-	G4LC	1,0	SILKR6C10E	97098		
Rio X-Line 1.4 MPi FB	1.4	74	4	11.17-	G4LC	1,0	SILKR6C10E	97098		

SEDONA

Sedona	2.5		6	09.99-	KV6	1,1	PFR6N-11	3546		LPG 1
--------	-----	--	---	--------	-----	-----	----------	------	--	-------

SHUMA I

Shuma I	1.5	65	4	05.98-	BFD	1,1	BKR6E-11	2756	14	LPG 1
---------	-----	----	---	--------	-----	-----	----------	------	----	-------





kW
C
Y
I



Stock-N°

VLINE

LPG/CNG

KIA

SHUMA I

Shuma I	1.8	82	4	05.98-	TED	0,9	BKR6E	6962	28	LPG 1
---------	-----	----	---	--------	-----	-----	-------	------	----	-------

SHUMA II

Shuma II FB522,FB624	1.6	75	4	04.01-	OKAB5	0,9	BKR6E	6962	28	LPG 1
Shuma II	1.8	82	4	.01-	TED	0,9	BKR6E	6962	28	LPG 1

SORENTO (JC)

Sorento	JC	2.4	102	4	08.02-08.06	G4JS	1,1	PGR5C-11	5760	
Sorento	JC	3.3	177	6	.06-	G6DB	1,1	IFR5G11	7854	
Sorento	JC	3.5	143	6	08.02-08.06	G6CU	1,1	PFR5N-11	5838	
Sorento	JC	3.8		6	.06-	G6DA	1,1	IFR5G11	7854	

SORENTO (UM)

Sorento 2.4 CVVT	UM	2.4	129	4	01.15-	G4KE	1,1	LF5A-11	6376	LPG 7
Sorento 3.5 D-CVVT	UM	3.5	183	6	12.18-	G6DC	1,1	SILZKR7B11	9723	

SORENTO (XM)

Sorento 2.4 CVVT BiFuel	XM	2.4	126	4	04.10-12.15	G4KE	1,1	LF5A-11	6376	LPG 7
Sorento 2.4 CVVT	XM	2.4	128	4	11.09-	G4KE	1,1	LF5A-11	6376	LPG 7
Sorento 2.4 GDi	XM	2.4	141	4	10.12-12.15	G4KJ	1,1	DILKR6A11	97319	

SOUL

Soul 1.6 CVVT	AM	1.6	77	4	02.09-	G4FC	1,0	LZKR6B-10E	1578	49
Soul 1.6 CVVT BiFuel	AM	1.6	87	4	06.11-12.14	G4FC	1,0	LZKR6B-10E	1578	49
Soul 1.6 CVVT	AM	1.6	91	4	09.09-12.14	G4FC	1,0	LZKR6B-10E	1578	49
Soul 1.6 CVVT BiFuel	AM	1.6	92	4	02.09-12.14	G4FC	1,0	LZKR6B-10E	1578	49
Soul 1.6 CVVT	AM	1.6	95	4	01.10-12.14	G4FC	1,0	LZKR6B-10E	1578	49
Soul 1.6 GDI	AM	1.6	103	4	06.11-	G4FD	1,0	SILZKR6B10E	93815	

SOUL II

Soul 1.6 MPi	PS	1.6	91	4	02.14-	G4FG	1,0	LZKR6B-10E	1578	49
Soul 1.6 LPG	PS	1.6	96	4	12.14-	G4FG	1,0	LZKR6B-10E	1578	49
Soul 2.0 CVVT	PS	2.0	110	4	08.16-	G4NA	1,1	SILZKR7B11	9723	
Soul 2.0 CVVT	PS	2.0	113	4	02.14-	G4NA	1,1	SILZKR7B11	9723	

SOUL III

Soul 1.6 MPi	SK3	1.6	91	4	01.19-	G4FG	1,0	LZKR6B-10E	1578	49
--------------	-----	-----	----	---	--------	------	-----	------------	------	----

SPORTAGE

Sportage 1.6 GDi	QLE	1.6	97	4	09.15-	G4FD	1,0	SILZKR6B10E	93815	
Sportage 1.6 GDi LPG	SL	1.6	99	4	01.14-12.15	G4FD	1,0	SILZKR6B10E	93815	
Sportage		2.0	70	4	.94-12.02	SOHC	0,8	BKR5E	7938	35 LPG 1
Sportage 16V		2.0	94	4	.94-08.04	DOHC 16V	1,1	BKR6E-11	2756	14 LPG 1
Sportage 2.0 CVVT BiFuel	KM	2.0	101	4	06.09-05.10	G4GC	1,1	BKR5ES-11	2382	LPG 1
Sportage 2.0		2.0	104	4	.06-	G4GC	1,1	BKR5ES-11	2382	33 LPG 1
Sportage 2.0 CVVT	SL	2.0	110	4	01.14-12.15	G4NA	1,1	SILZKR7B11	9723	
Sportage 2.0 CVVT	QL, QLE	2.0	110	4	12.15-	G4NA	1,1	SILZKR7B11	9723	
Sportage 2.0 CVVT	SL	2.0	113	4	11.14-12.15	G4NA	1,1	SILZKR7B11	9723	
Sportage 2.0 CVVT	QL, QLE	2.0	114	4	12.15-	G4NA	1,1	SILZKR7B11	9723	
Sportage 2.0 CVVT	KM	2.0	122	4	01.09-05.10	G4KD	1,1	BKR5ES-11	2382	LPG 1
Sportage 2.7 CVVT	KM	2.7	129	6	11.06-05.10	G6BA	1,1	IFR5G11	7854	
Sportage 2.7		2.7	129	6	.06-	G6BA V6	1,1	PFR5N-11	5838	





l kW C
Y
I



Stock-N°

VLINE

LPG/CNG

KIA

SPORTAGE (SL)

Sportage 1.6 GDI	SL	1.6	99	4	06.10-	G4FD	1,0	SILZKR6B10E	93815		
Sportage 2.0 CVVT	SL	2.0	120	4	07.10-	G4KD	1,1	LFR5A-11	6376		LPG 7

STONIC

Stonic 1.0 T-GDi	YB	1.0	74	3	08.18-	G3LC	0,7	ILKR9Q7G	97312		
Stonic 1.0 T-GDi	YB	1.0	88	3	07.17-	G3LC	0,7	ILKR9Q7G	97312		
Stonic 1.2 CVVT	YB	1.2	62	4	07.17-	G4LB	1,0	SILKR6C10E	97098		
Stonic 1.4 LPG	YB	1.4	71	4	11.18-	G4LC	1,0	SILKR6C10E	97098		
Stonic 1.4 CVVT	YB	1.4	73	4	07.17-	G4LC	1,0	SILKR6C10E	97098		

VENGA

Venga 1.4		1.4	66	4	10.09-	G4FA	1,0	LZKR6B-10E	1578	49	
Venga 1.4 LPG	YN	1.4	66	4	02.10-	G4FA	1,0	LZKR6B-10E	1578	49	
Venga 1.4 CVVT	YN	1.4	66	4	04.15-	G4FA	1,0	LZKR6B-10E	1578	49	
Venga 1.6		1.6	92	4	10.09-	G4FC	1,0	LZKR6B-10E	1578	49	
Venga 1.6 CVVT	YN	1.6	92	4	02.15-	G4FC	1,0	LZKR6B-10E	1578	49	

XCEED (CD)

Xceed 1.0 T-GDi	CD	1.0	88	3	06.19-	G3LC	0,7	ILKR9Q7G	97312		
Xceed 1.4 T-GDi	CD	1.4	103	4	06.19-	G4LD	0,7	ILKR9Q7G	97312		

LADA (AVTOVAZ)

112

112 2112 16V		1.5	54	4	01.96-	VAZ2111	0,8	BPR6ES	7822	2	LPG 2
112 Gli		1.5	67	4	.03-	16V	1,1	BCPR6ES-11	7121	11	LPG 3

2108

21080 Samara 1.3		1.3	48	4	01.84-		0,8	BPR6ES	7822	2	LPG 2
------------------	--	-----	----	---	--------	--	-----	--------	------	---	-------

21099

210993 Samara 1.5		1.5	53	4	01.90-		0,8	BPR6ES	7822	2	LPG 2
-------------------	--	-----	----	---	--------	--	-----	--------	------	---	-------

2110

2110 1.5		1.5	53	4	06.96-		0,8	BPR6ES	7822	2	LPG 2
2110		1.5	56	4	.96-		0,8	BPR6ES	7822	2	LPG 2
2110		1.5	58	4	.97-		0,8	BPR6ES	7822	2	LPG 2

2111

2111		1.5	58	4	.97-		0,8	BPR6ES	7822	2	LPG 2
------	--	-----	----	---	------	--	-----	--------	------	---	-------

2115

2115 1.5		1.5	53	4	.00-		0,8	BPR6ES	7822	2	LPG 2
2115 1.5i		1.5	57	4	01.00-	VAZ2111	1,1	BPR6ES-11	4824	13	LPG 2

2120

2120 Nadeschda 1.7i		1.7	60	4	01.98-	BA3-21214	1,1	BPR6ES-11	4824	13	LPG 2
2120 Nadeschda 1.8		1.8	59	4	01.98-	BA3-2130	0,8	BPR6ES	7822	2	LPG 2

2121

2121 Niva		1.6	51	4	12.76-		0,7	BP6ES	7811	4	LPG 2
-----------	--	-----	----	---	--------	--	-----	-------	------	---	-------

FORMA

Forma		1.3		4	09.91-		0,8	BPR6ES	7822	2	LPG 2
Forma		1.5	50	4	09.91-		0,8	BPR6ES	7822	2	LPG 2

LADA 110

21102 i		1.5	57	4	01.96-	BA3 2111	1,1	BPR6ES-11	4824	13	LPG 2
21103 16V		1.5	67	4	01.96-	BA3 2112	1,1	BCPR6ES-11	7121	11	LPG 3





l kW C
Y
I



Stock-N°

VLINE

LPG/CNG

LADA (AVTOVAZ)

LADA 110

Lada 110 21101 8V	1.6	59	4	.04-		1,1	BPR6ES-11	4824	13	LPG 2
Lada 110 21104	1.6	66	4	.04-		1,1	BCPR6ES-11	7121	11	LPG 3
2110 GTi 16V	2.0	110	4	01.96-	C20XE Opel	0,9	BKR6E	6962	28	LPG 1
110 2.0 GTI	2.0	110	4	01.00-	C20XE	0,9	BKR6EK	2288	20	LPG 1

LADA 111

21111	1.5	53	4	01.98-	BA3 2120	0,8	BPR6ES	7822	2	LPG 2
21110 i	1.5	57	4	01.98-	BA3 2111	1,1	BPR6ES-11	4824	13	LPG 2
21113 16V	1.5	67	4	01.98-	BA3 2112	1,1	BCPR6ES-11	7121	11	LPG 3
Lada 111 21112 8V	1.6	59	4	.04-		1,1	BPR6ES-11	4824	13	LPG 2
Lada 111 21114 16V	1.6	66	4	.04-		1,1	BCPR6ES-11	7121	11	LPG 3

LADA 112

21122 i	1.5	57	4	01.00-	VAZ2111	1,1	BPR6ES-11	4824	13	LPG 2
21120 16V	1.5	67	4	01.00-	VAZ2112	1,1	BCPR6ES-11	7121	11	LPG 3
Lada 112 21121 8V	1.6	59	4	.04-		1,1	BPR6ES-11	4824	13	LPG 2
Lada 112 21124 16V	1.6	66	4	.04-		1,1	BCPR6ES-11	7121	11	LPG 3

LADA 2104

21043 / Nova Kombi	1.5	53	4	01.88-	BA3-2103	0,7	BP6ES	7811	4	LPG 2
--------------------	-----	----	---	--------	----------	-----	-------	------	---	-------

LADA 2105

21050	1.5	53	4	01.88-	BA3 21011	0,7	BP6ES	7811	4	LPG 2
-------	-----	----	---	--------	-----------	-----	-------	------	---	-------

LADA 2107

21070	1.3	47	4	01.82-	BA3 21011	0,7	BP6ES	7811	4	LPG 2
21073	1.5	53	4	01.88-	BA3 2103	0,7	BP6ES	7811	4	LPG 2

LADA KALINA

Lada Kalina 1117	1.6	58	4	10.04-	BA3 11183	1,1	BCPR6ES-11	7121	11	LPG 3
Lada Kalina 1118	1.6	58	4	10.04-	BA3 11183	1,1	BCPR6ES-11	7121	11	LPG 3
Lada Kalina 1119	1.6	58	4	10.04-	BA3 11183	1,1	BCPR6ES-11	7121	11	LPG 3
Lada Kalina 1117 8V	1.6	59	4	.05-		1,1	BPR6ES-11	4824	13	LPG 2
Lada Kalina 1118 8V	1.6	59	4	.05-		1,1	BPR6ES-11	4824	13	LPG 2
Lada Kalina 1119 8V	1.6	59	4	.05-		1,1	BPR6ES-11	4824	13	LPG 2
Lada Kalina 1117 16V	1.6	65	4	10.04-	BA3 21124	1,1	BCPR6ES-11	7121	11	LPG 3
Lada Kalina 1118 16V	1.6	65	4	10.04-	BA3 21124	1,1	BCPR6ES-11	7121	11	LPG 3
Lada Kalina 1119 16V	1.6	65	4	10.04-	BA3 21124	1,1	BCPR6ES-11	7121	11	LPG 3

LADA NIVA

Lada Niva 2129 1.7 Niva	1.7	59	4	.93-		0,8	BPR6ES	7822	2	LPG 2
-------------------------	-----	----	---	------	--	-----	--------	------	---	-------

LADA SAMARA

21081 / Fun 1100	1.1	39	4	01.84-		0,8	BPR6ES	7822	2	LPG 2
21091	1.1	39	4	01.87-		0,8	BPR6ES	7822	2	LPG 2
21090	1.3	48	4	01.87-	BA3 2108	0,8	BPR6ES	7822	2	LPG 2
21099	1.3	48	4	01.90-	BA3 2108	0,8	BPR6ES	7822	2	LPG 2
21083 / Fun 1500	1.5	53	4	01.84-	BA3 2103	0,8	BPR6ES	7822	2	LPG 2
21093	1.5	53	4	01.87-	BA3 2103	0,8	BPR6ES	7822	2	LPG 2
Lada Samara 2113 8V	1.5	56	4	.04-		1,1	BPR6ES-11	4824	13	LPG 2
2114 i	1.5	57	4	01.01-	BA3 2111	1,1	BPR6ES-11	4824	13	LPG 2

LADA TOSCANA

2107 Toscana	1.5	55	4	07.88-		0,7	BP6ES	7811	4	LPG 2
--------------	-----	----	---	--------	--	-----	-------	------	---	-------





l kW C
Y
I



Stock-N°

VLINE

LPG/CNG

LADA (AVTOVAZ)

NIVA

21210 Niva 1.6	1.6	51	4	01.77-	BA3 2121	0,7	BP6ES	7811	4	LPG 2
21213 Niva 1.7	1.7	55	4	01.93-		0,8	BPR6ES	7822	2	LPG 2
Niva	1.7	59	4	.95-		0,8	BPR6ES	7822	2	LPG 2
21310 Niva 1.7i	1.7	60	4	01.95-	BA3-21214	1,1	BPR6ES-11	4824	13	LPG 2
21214 Niva 1.7i	1.7	60	4	01.01-	BA3-21214	1,1	BPR6ES-11	4824	13	LPG 2
21312 Niva 1.8	1.8	59	4	01.95-	BA3-2130	0,8	BPR6ES	7822	2	LPG 2

NOVA

Nova / Vaz 21051	1.2	44	4	07.88-		0,8	BPR6ES	7822	2	LPG 2
Nova / Vaz 2102, 2105	1.3	48	4	07.88-		0,8	BPR6ES	7822	2	LPG 2
Nova / Vaz 21043	1.5	55	4	07.88-		0,8	BPR6ES	7822	2	LPG 2
Nova i	1.7	59	4	11.94-		0,8	BPR6ES	7822	2	LPG 2
Nova i	1.7	62	4	11.94-		0,8	BPR6ES	7822	2	LPG 2
Nova / Vaz 2104, 2105		55	4	07.88-		0,8	BPR6ES	7822	2	LPG 2
Nova / Vaz 2107		57	4	07.88-		0,8	BPR6ES	7822	2	LPG 2

OKA

1111 Oka / 640	0.65	22	2	09.89-	BA3 1111	0,7	BCP6ES	4930	17	LPG 3
Oka /640	0.65	22	2	09.89-	Vaz 1111	0,7	BCP6ES	4930	17	LPG 3
1111 Oka 1.3	1.3	46	4	01.98-	A-Plus ROV	0,8	BPR6ES	7822	2	LPG 2
Oka 1.3 VAZ-1111	1.3	46	4	01.98-	A-Plus ROV	0,8	BPR6ES	7822	2	LPG 2

RIVA

Riva 1200	1.2	47	4	11.85-	OHC 21012	0,7	BP6ES	7811	4	LPG 2
Riva 1300	1.3	49	4	11.85-	OHC 21056	0,7	BP6ES	7811	4	LPG 2
Riva 1500	1.5	55	4	11.85-	OHC 21026	0,7	BP6ES	7811	4	LPG 2
Riva 1600	1.6	63	4	01.86-	OHC 21062	0,7	BP6ES	7811	4	LPG 2

SAGONA

Sagona i	1.5		4	07.94-		0,9	BPR5ES	7422	6	LPG 2
Sagona GLX	1.5		4	07.95-		0,8	BPR6ES	7822	2	LPG 2

SAMARA

Samara Fun	1.1	39	4	09.91-		0,8	BPR6ES	7822	2	LPG 2
Samara / Vaz 2108	1.1	41	4	07.88-		0,8	BPR6ES	7822	2	LPG 2
Samara / Vaz 2108	1.3	46	4	07.88-		0,8	BPR6ES	7822	2	LPG 2
Samara Sport	1.5	65	4	.96-		0,8	BPR6ES	7822	2	LPG 2

TOSCANA

Toscana	1.5	55	4	01.86-		0,7	BP6ES	7811	4	LPG 2
---------	-----	----	---	--------	--	-----	-------	------	---	-------

LAMBORGHINI

GALLARDO

Gallardo	5.0	368	10	.02-05.05	L140	0,7	BKR8EIX	2668		
Gallardo Coupe	5.0	382	10	05.05-	L140	0,8	PFR7G	4364		
Gallardo Spider	5.0	382	10	05.05-	L140	0,8	PFR7G	4364		
Gallardo Coupe Superleggera	5.0	390	10	06.07-	L140	0,8	PFR7G	4364		

MURCIELAGO

Murciélago Coupe	6.5	471	12	04.06-	L537	0,8	KR8BI	4347		
Murciélago LP640 Coupe / Roadster	6.5	471	12	.07-	L537	0,8	KR8BI	4347		





l kW C
Y
I



Stock-N°

VLINE

LPG/CNG

LANCIA

DEDRA

Dedra 1.6L i.e.	1.6	57	4	08.89-09.94	835A1.046 Cat.	0,8	BPR6ES	7822	2	LPG 2
Dedra 1.6 iE 835AB	1.6	57	4	09.89-06.94	835A1.046	0,8	BPR7ES	2023		BPR8EIX
Dedra 1.6 iE 835AA, 835EB	1.6	66	4	08.89-07.99	835A1.000	0,8	BPR6ES	7822		LPG 2
Dedra 1.6L - LE/S.W. LE	1.6	66	4	10.94-02.98	159B9.000	0,9	BCPR7ES	3330		BCPR7EIX
Dedra 1.6	1.6	66	4	03.97-02.98	159B9.000	0,9	BCPR7ES	3330		BCPR7EIX
Dedra 1.6i.e. LE	1.6	66	4	07.97-02.98	159B9.000	0,9	BCPR7ES	3330		BCPR7EIX
Dedra 1.6i.e. S.W. LE	1.6	66	4	07.97-02.98	159B9.000	0,9	BCPR7ES	3330		BCPR7EIX
Dedra 1.6L S.W.	1.6	66	4	03.98-	159B9.000	0,9	BCPR7ES	3330		BCPR7EIX
Dedra 1.6 -/iE 835EI	1.6	76	4	02.97-09.99	182A4.000	0,9	BKR6EKC	2848	26	LPG 1
Dedra 1.6i.e. S.W. 16V	1.6	76	4	03.98-01.00	182A4.000	0,9	BKR5EZ	7642	36	LPG 1
Dedra 1.6i.e. 16V	1.6	76	4	03.98-01.00	182A4.000	0,9	BKR5EZ	7642	36	LPG 1
Dedra 1.8 iE 835AT	1.8	66	4	08.93-07.99	835C5.000	0,8	BPR7ES	2023		BPR8EIX
Dedra 1.8 -/iE 835FA	1.8	74	4	07.94-07.99	836A5.000	0,8	BPR7ES	2023		BPR8EIX
Dedra 1.8 -/iE 835FA	1.8	74	4	07.94-08.97	836A5.000	0,8	BPR7ES	2023		BPR8EIX
Dedra 1.8L - LE-LS-SW	1.8	74	4	10.94-02.98	835A2.046	0,9	BCPR7ES	3330		BCPR7EIX
Dedra i.e./ LE	1.8	77	4	01.89-09.94	835A2.046 Cat.	0,8	BPR7ES	2023	19	BPR8EIX
Dedra 1.8- 16V	1.8	83	4	07.97-01.00	182A2.000	0,9	BKR6EKC	2848	26	LPG 1
Dedra i.e. / LS	2.0	83	4	01.89-09.94	835A5.046 Cat.	0,8	BPR7ES	2023	19	BPR8EIX
Dedra i.e. automatica LS	2.0	83	4	10.94-04.97	835A5.046	0,8	BPR7ES	2023	19	BPR8EIX
Dedra 2.0L-16V- S.W.LX / integral	2.0	102	4	10.94-02.98	836A3.000	0,8	BPR7ES	2023	19	BPR8EIX
Dedra 2000 Turbo	2.0	119	4	08.91-02.98	835A8.046	0,8	BP6ET	1263		LPG 2
Dedra i.e. Turbo/Integr.	2.0	124	4	01.91-09.94	835A7.046 Cat.	0,8	BP6ET	1263		LPG 2

DELTA

Delta / LX	1.3	57	4	- .93	831A...- 831B.000	0,8	BPR7ES	2023	19	BPR8EIX
Delta 1.4 T-JET 120CV 844	1.4	88	4	.08-	198A4.000	0,8	IKR9J8	93311		
Delta 1.4 T-JET 150CV 844	1.4	110	4	.08-	198A1.000	0,8	IKR9J8	93311		
Delta / LX / Automatic	1.5	59	4	- .93	831A...- 831B.000	0,8	BPR7ES	2023	19	BPR8EIX
Delta	1.6	55	4	09.93-11.97	851C1.000	0,9	BCPR7ES	3330		BCPR7EIX
Delta (836)	1.6	66	4	03.96-02.98	182A6.000	0,9	BCPR7ES	3330		BCPR7EIX
Delta 16V - HPE	1.6	76	4	06.96-11.97	182A4.000	0,9	BKR6EKC	2848	26	LPG 1
Delta 1.6i.e. 16V HPE; LS	1.6	76	4	12.97-02.98	182A4.000	0,9	BKR6EKC	2848	26	LPG 1
Delta	1.6	76	4	03.98-01.00	182A4.000	0,9	BKR5EZ	7642	36	LPG 1
Delta i.e. GT	1.6	77	4	- .93	182A4.000 Cat	0,8	BPR6ES	7822	2	LPG 2
Delta GT	1.6	77	4	- .93	831A4.000	0,8	BPR7ES	2023	19	BPR8EIX
Delta i.e. / Turbo HF	1.6	95	4	- .93	831A7.000 Cat.	0,8	BPR7ES	2023	19	BPR8EIX
Delta i.e. / LE	1.8	66	4	09.93-11.97	835C4.000	0,8	BPR7ES	2023	19	BPR8EIX
Delta 16V/ HPE	1.8	96	4	06.96-11.97	183A1.000	0,9	BKR6EKC	2848	26	LPG 1
Delta 1.8- 16V- HPE/LS	1.8	96	4	12.97-01.00	183A1.000	0,9	BKR6EKC	2848	26	LPG 1
Delta i.e. 16V / LS	2.0	102	4	09.93-11.97	836A3.000	0,8	BPR7ES	2023	19	BPR8EIX
Delta i.e. 16V GT	2.0	102	4	10.94-11.97	836A3.000	0,8	BPR7ES	2023	19	BPR8EIX
Delta HPE ie	2.0	102	4	06.95-		0,8	BPR7ES	2023	19	BPR8EIX
Delta i.e. HPE Turbo 16V	2.0	137	4	01.93-09.96	836A2.000	0,8	BPR7ES	2023	19	BPR8EIX
Delta Turbo	2.0	137	4	09.93-11.97	836A2.000	0,8	BP6ET	1263		LPG 2
Delta HPE Turbo 16V HF	2.0	137	4	06.95-		0,8	BUR6ET	3172	1	LPG 2
Delta i.e. HPE Turbo 16V HF	2.0	142	4	12.97-01.00	175A4.000	0,9	BCPR6ET	2197		LPG 3





l kW C
Y I



Stock-N°

VLINE

LPG/CNG

LANCIA

DELTA

Delta i.e. Turbo HF 16V Inte	2.0	144	4	10.87-11.97	831 C5.000	0,8	BPR7ES	2023	19	BPR8EIX
Delta HF Integrale Evo 3	2.0	144	4	07.92-11.97	831C5.046	0,8	BP6ET	1263		LPG 2
Delta i.e. Turbo HF Integr.	2.0	144	4	07.92-11.97	831C5.046	0,8	BPR7ES	2023	19	BPR8EIX
Delta HF integrale Spec.ed.	2.0	155	4	02.94-11.97	831E5.046	0,8	BUR6ET	3172	1	LPG 2

DELTA 3 (844)

Delta 3 1.4 T-Jet	844	1.4	88	4	09.08-	198A4.000	0,8	IKR9J8	93311	
Delta 3 1.4 T-Jet LPG	844	1.4	88	4	10.09-	198A4.000	0,8	IKR9J8	93311	
Delta 3 1.4 T-Jet	844	1.4	103	4	07.10-	198A7.000	0,8	IKR9J8	93311	
Delta 3 1.4 T-Jet	844	1.4	110	4	09.08-	198A1.000	0,8	IKR9J8	93311	
Delta 3 1.8 Di TURBO-JET	844	1.8	147	4	05.09-	939B1.000	0,6	ILKAR7D6G	93607	

K

K	2.0	114	4	11.94-02.01	838A6.000	0,9	BKR6EKC	2848	26	LPG 1
K	2.0	114	4	07.98-02.01	838A6.000	0,9	BCPR6ET	2197		LPG 3
K 20V LS; S.W.	2.0	114	5	07.98-02.01	838A6.000	0,9	BKR6EKC	2848	26	LPG 1
K turbo	2.0	151	4	02.95-06.98	838A4.000	0,8	BP6ET	1263		LPG 2
K Turbo 16V Coupe	2.0	151	4	07.97-06.98	838A4.000	0,8	BP6ET	1263		LPG 2
K i. 20V LS/LE/LX/SW	2.4	129	5	01.95-02.01	838A2.000	0,9	BKR6EKC	2848	26	LPG 1
K i 20V Coupe	2.5	129	5	07.97-02.01	838A2.000	0,9	BKR6EKC	2848	26	LPG 1
K V6 - 24V-LX/LS/SW/Coupe	3.0	150	6	01.95-02.01	838B.000	0,9	PFR6B	3500		LPG 1
K i V6 24V aut. Coupe	3.0	150	6	07.97-02.01	838B.000	0,9	PFR6B	3500		LPG 1
K i. V6 24 V LS; aut LX; S.W.; Coupe	3.0	150	6	07.98-02.01	838B.000	0,9	PFR6B	3500		LPG 1

KAPPA

KAPPA 2.0 -/iE	838AG11A, 838AG1AA	2.0	114	5	09.96-12.01	838A6.000	0,9	BKR6EKC	2848	26	LPG 1
KAPPA S.W. 2.0 iE	838BG11A, 838BG1AA	2.0	114	5	09.96-05.01	838A6.000	0,9	BKR6EKC	2848	26	LPG 1
KAPPA 2.0 iE	838AM1AA	2.0	162	5	03.98-12.01	175A3.000	0,8	BKUR6ETB	6992		
KAPPA S.W. 2.0 iE	838BM1AA, 838XB1AA	2.0	162	5	03.98-05.01	175A3.000	0,8	BKUR6ETB	6992		
KAPPA Coupe 2.0 iE	838CM	2.0	162	5	06.98-03.01	175A3.000	0,8	BKUR6ETB	6992		
KAPPA 2000 20V 150CV		2.0	110	5	01.95-	838A1.000	0,9	BKR6EKC	2848	26	LPG 1
KAPPA 2000 16V TURBO		2.0	151	4	02.95-02.01	838A4.000	0,8	BP6ET	1263		LPG 2
KAPPA 2000 TURBO 20V		2.0	162	5	07.98-02.01	175A3.000	0,8	BKUR6ETB	6992		
KAPPA 2400 20V 175CV		2.4	129	5	01.95-02.01	838A2.000	0,9	BKR6EKC	2848	26	LPG 1
KAPPA 3000 V6 24V		3.0	150	6	01.95-02.01	838B.000	0,9	PFR6B	3500		LPG 1

LYBRA

Lybra 1.6	839AXA1A	1.6	76	4	07.99-09.01	182A4.000	0,9	BKR6EKC	2848	26	LPG 1
Lybra Estate/Wagon 1.6	839BXA1A	1.6	76	4	07.99-09.01	182A4.000	0,9	BKR6EKC	2848	26	LPG 1
Lybra 16V;Lx;S.W.		1.6	76	4	09.99-	182A4.000	0,9	BKR5EZ	7642	36	LPG 1
Lybra 1.6	839AXF1A	1.6	76	4	10.00-10.05	182B6.000	0,9	BKR6EKC	2848	26	LPG 1
Lybra Estate/Wagon 1.6	839BXF1A	1.6	76	4	10.00-10.05	182B6.000	0,9	BKR6EKC	2848	26	LPG 1
Lybra 1.8 (Chassis No 1945439-→)	839AXB1A, 839AXG1A	1.8	96	4	07.99-10.05	839A4.000, 839A7.000, 839A9.000	0,9	BKR6EZ	4619	38	LPG 1
Lybra Estate/Wagon 1.8 (Chassis No 1945439-→)	839BXB1A, 839BXG1A	1.8	96	4	07.99-10.05	839A4.000, 839A7.000, 839A9.000	0,9	BKR6EZ	4619	38	LPG 1
Lybra 16V;Lx;S.W.		1.8	96	4	09.99-08.02	839A4.000	0,9	BKR6EKC	2848	26	LPG 1
Lybra 16V;Lx;S.W.		1.8	96	4	09.02-	839A4.000	0,9	BKR6EZ	4619	38	LPG 1
Lybra 20V;Lx;S.W.;Aut.		2.0	110	5	09.99-08.02	182B7.000	0,9	BKR6EKC	2848	26	LPG 1





l kW C
Y
I



Stock-N°

VLINE

LPG/CNG

LANCIA

LYBRA

Lybra 2.0	839AXH11, 839AXH1A	2.0	110	5	10.00-10.05	185A8.000	0,9	BKR6EZ	4619	38	LPG 1
Lybra Estate/Wagon 2.0	839BXH11, 839BXH1A	2.0	110	5	10.00-10.05	185A8.000	0,9	BKR6EZ	4619	38	LPG 1
Lybra 20V;Lx;S.W.;Aut.		2.0	110	5	09.02-	182B7.000	0,9	BKR6EZ	4619	38	LPG 1
Lybra 2.0	839AXC11, 839AXC1A	2.0	113	5	07.99-09.00	182B7.000	0,9	BKR6EZ	4619	38	LPG 1
Lybra Estate/Wagon 2.0	839BXC11, 839BXC1A	2.0	113	5	07.99-09.00	182B7.000	0,9	BKR6EZ	4619	38	LPG 1
Lybra 2.4	839CXM1A	2.4	125	5	10.01-10.05	192A2.000	0,9	BKR6EZ	4619	38	LPG 1

MUSA

Musa 1.4		1.4	57	4	09.05-	350A1.000	1,0	ZKR7A-10	1691	42	LPG 8
Musa 1.4 LPG (Euro 4)		1.4	57	4	04.09-	350A1.000	1,0	ZKR7A-10	1691	42	LPG 8
Musa 1.4 LPG (Euro 4)	350AXF1A	1.4	57	4	09.09-12.12	350A1.000	1,0	ZKR7A-10	1691	42	LPG 8
Musa 1.4 LPG (Euro 5)		1.4	57	4	11.10-	350A1.000	0,8	ZKR7AI-8	92402		
Musa 1.4	350AXE1A	1.4	66	4	09.04-12.12	192B2.000	1,0	DCPR7E-N-10	4983	43	
Musa 1.4 16V		1.4	66	4	10.04-12.12	192B2.000	1,0	DCPR7E-N-10	4983	43	
Musa 1.4 16V		1.4	70	4	09.04-02.05	843A1.000	0,9	DCPR7E-N-10	4983	43	
Musa 1.4 16V		1.4	70	4	03.05-	843A1.000	1,0	DCPR7E-N-10	4983	43	

PHEDRA

Phedra 2.0		2.0	100	4	10.02-11.10	EW10J4 RFN	0,9	LFR5B	7113	46	LPG 7
Phedra 3.0 V6		3.0	150	6	10.02-	XFW	1,1	PLFR5A-11	6240		LPG 7

THEMA

Thema i.e. / Wagon		2.0	85	4	-01.95	834B.146 Cat.	0,8	BPR7ES	2023	19	BPR8EIX
Thema i.e. 16V Tur. SW/LS/LX		2.0	108	4	-01.95	834B2.000	0,8	BP6ET	1263		LPG 2
Thema i.e. Turbo SW		2.0	110	4	-01.95	834C146 Cat.	0,8	BPR7ES	2023	19	BPR8EIX
Thema i.e. 16V S.W. Fairway		2.0	112	4	04.94-01.95	834F1.000	0,8	BPR7ES	2023	19	BPR8EIX
Thema i.e. Turbo		2.0	122	4	-01.95	834C146	0,8	BPR7ES	2023	19	BPR8EIX
Thema i.e. Turbo 16V LX		2.0	148	4	10.91-01.95	834F2.000 Cat.	0,8	BP6ET	1263		LPG 2
Thema i.e. Turbo 16V		2.0	148	4	04.94-		0,8	BP6ET	1263		LPG 2
Thema i.e. Turbo 16V S.W.Fairway		2.0	148	4	04.94-01.95	834C1.246	0,8	BUR6ET	3172	1	LPG 2
Thema i.e. V6		2.8	110	6	-01.95	PRV834AB Cat.	1,0	BPR6EFS	3623	7	LPG 5
Thema i.e. V6 LS / LX / SW		3.0	126	6	.92-01.95	834F.000	0,8	BPR7ES	2023	19	BPR8EIX
Thema 8.32		3.0	150	8	.90- .92	F105L Cat.	0,7	DCPR9E	2641		

THESIS

Thesis 2.0 20 V TB		2.0	136	5	11.02-	841E.000	0,8	BKUR6ETB	6992		
Thesis 2.0 TB cambio 6 marce		2.0	136	5	11.02-	841E.000	0,8	BKUR6ETB	6992		
Thesis 2.4 20V		2.4	125	5	11.02-	841D.000	0,9	BKR6EZ	4619	38	LPG 1
Thesis 3.0 24V V6		3.0	158	6	11.02-	841A.000	0,9	PFR6B	3500		LPG 1
Thesis 3.2 24V V6		3.2	169	6	11.03-	841A.000	0,9	PFR6B	3500		LPG 1

Y (YPSILON)

Y 10 4WD		1.0	33	4	.85-10.96	156A2.246	0,8	BCPR6ES	2330	12	LPG 3
Y 10 Fire		1.0	33	4	.85-10.96	156A2.000	0,8	BCPR6ES	2330	12	LPG 3
Y 10 /4x4		1.1	37	4	09.86-10.96	156C.046	0,6	BCPR7ES	3330		BCPR7EIX
Y 10 Selectronic i.e.		1.1	37	4	-10.96	156C.046 Cat	0,8	BCPR6ES	2330	12	LPG 3
Y (Ypsilon) 1.1 -iE	840AE1A	1.1	40	4	09.95-07.00	176B2.000	0,9	BKR6E	6962	28	LPG 1
Y Elefantino Blu		1.1	40	4	05.97-09.00	176B2.000	0,8	BCPR6ES	2330	12	LPG 3
Y Elefantino Blu		1.1	40	4	05.97-04.00	176B2.000	0,9	BKR6E	6962	28	LPG 1





l kW C
Y
I



Stock-N°

VLINE

LPG/CNG

LANCIA

Y (YPSILON)

Y 8 V	1.2	44	4	01.96-03.97	840A3.000	0,8	BCPR6ES	2330	12	LPG 3
Y 8 V LS,LE;ECVT	1.2	44	4	01.96-10.99	840A3.000	0,8	BCPR6ES	2330	12	LPG 3
Y 8 V Elefantino Blu -unica	1.2	44	4	10.99-09.03	188A4.000	0,9	BKR5EZ	7642	36	LPG 1
Y 1.2 8V: Vanity- LS-Unica	1.2	44	4	10.00-12.03	188A4.000	0,9	BKR5EZ	7642	36	LPG 1
Y (Ypsilon) 1.2 840AG1A	1.2	59	4	08.00-09.03	188A5.000	0,9	DCPR8E-N	5692		LPG 8
Y 16V elefantino Blu /Rosso	1.2	59	4	10.00-11.02	188A5.000	0,9	DCPR8E-N	5692		LPG 8
Y 1.2 16V- LS-LX-Unica	1.2	59	4	10.00-11.02	188A5.000	0,9	DCPR8E-N	5692		LPG 8
Y 1.2 16V- LS-LX-Unica	1.2	59	4	12.02-12.03	188A5.000	0,9	DCPR7E-N-10	4983	43	
Y 16V	1.2	63	4	04.97-03.00	176B9.000	0,9	DCPR8E	4339		LPG 8
Y 16V,LE,LS,LX, Elefantino Rosso	1.2	63	4	04.97-04.00	176B9.000	0,9	DCPR8E	4339		LPG 8
Y (Ypsilon) 1.2 840AD1A	1.2	63	4	04.97-12.99	176B9.000	0,9	DCPR8E	4179		LPG 8
Y 16V LE	1.2	63	4	02.98-09.00	176B9.000	0,9	DCPR8E	4339		LPG 8
Y 10 1300; G.T.	1.3	53	4	11.87-10.96	146A5.046	0,8	BPR6ES	7822	2	LPG 2
Y	1.4	55	4	01.96-12.97		0,9	BCPR6ET	2197		LPG 3
Y i. 12V	1.4	55	4	01.96-01.98	840A2.000 - 840A4.000	0,9	BKR6EKC	2848	26	LPG 1
Y i.e. 12V	1.4	59	4	01.96-01.98	840A4.000	0,9	BKR6EKC	2848	26	LPG 1

YPSILON

Ypsilon 1.2 (Engine 2533529->; Euro 4) 843AXA1A	1.2	44	4	10.03-12.11	188A4.000	1,0	DCPR7E-N-10	4983	43	
Ypsilon 1.2 (Euro 5) 843AXA1A	1.2	44	4	10.03-12.11	188A4.000	1,0	ZKR7A-10	1691	42	LPG 8
Ypsilon 1.2 (Euro 4) 843AXL1A	1.2	51	4	08.10-12.11	169A4.000	1,0	DCPR7E-N-10	4983	43	
Ypsilon 1.2 Bi-fuel 312YXA1A	1.2	51	4	05.11-	169A4.000	0,8	ZKR7AI-8	92402		

YPSILON (843)

Ypsilon 1.2 8V (843) 843	1.2	44	4	09.03-10.04	188A4.000	0,9	BKR5EZ	7642	36	LPG 1
Ypsilon 1.2 (843) 843	1.2	44	4	10.04-	188A4.000	1,0	DCPR7E-N-10	4983	43	
Ypsilon 1.2 (843) 843	1.2	51	4	09.10-	169A5.000	1,0	ZKR7A-10	1691	42	LPG 8
Ypsilon 16V (843) 843	1.2	57	4	09.03-02.05	188A5.000	0,9	DCPR7E-N-10	4983	43	
Ypsilon 16V (843) 843	1.2	57	4	02.05-	188A5.000	1,0	DCPR7E-N-10	4983	43	
Ypsilon 1.4 (843) 843	1.4	57	4	09.06-	350A1.000	1,0	ZKR7A-10	1691	42	LPG 8
Ypsilon 1.4 LPG (843) 843	1.4	57	4	04.09-	350A1.000	1,0	ZKR7A-10	1691	42	LPG 8
Ypsilon 1.4 16V (843) 843	1.4	70	4	09.03-02.05	843A1.000	0,9	DCPR7E-N-10	4983	43	
Ypsilon 1.4 16V (843) 843	1.4	70	4	02.05-	843A1.000	1,0	DCPR7E-N-10	4983	43	

YPSILON (846)

Ypsilon 0.9 Twinair 846	0.9	63	2	05.11-	312A2.000	0,8	ILKR9G8	97168		
Ypsilon 0.9 Twinair CNG 846	0.9	63	2	06.13-	312A2.000	0,8	ILKR9G8	97168		
Ypsilon 1.2 LPG 846	1.2	49	4	05.11-	169A4.000	0,8	ZKR7AI-8	92402		
Ypsilon 1.2 846	1.2	51	4	05.11-	169A4.000	1,0	ZKR7A-10	1691	42	LPG 8

ZETA

Zeta i.e.	2.0	89	4	04.99-12.01	RFV	0,8	BKR5EK	7956	23	LPG 1
Zeta 2.0 16V	2.0	100	4	07.00-09.02	RFN	0,9	LFR5B	7113	46	LPG 7
Zeta i. Turbo,LS	2.0	108	4	10.94-	RGX	0,8	BKR6EK	2288	20	LPG 1
Zeta i.e. Turbo,LS	2.0	108	4	10.94-03.99	RGX	0,9	BKR6EK	2288	20	LPG 1

LAND ROVER

DEFENDER

Defender 2.5	2.5		6	.90-		0,8	BP6ES	7811	4	LPG 2
Defender 3.5 V8	3.5		8	.90-		0,9	BPR5ES	7422	6	LPG 2





€ kW C Y I



Stock-N°

VLINE

LPG/CNG

LAND ROVER

DISCOVERY

Discovery 2.0	2.0	99	4	06.93-01.99	Mpi	0,9	BKR6E	6962	28	LPG 1
Discovery V8	3.5	107	8	09.89-01.99	V8 3.5	0,8	BPR6ES	7822	2	LPG 2
Discovery V8	3.9	136	8	02.99-	V8	0,8	BPR6ES	7822	2	LPG 2
Discovery	4.0		8	.94- .99		0,8	BPR6ES	7822	2	LPG 2
Discovery	4.0		8	10.98-		1,1	PFR6N-11	3546		LPG 1
Discovery 3 4.4	4.4	220	8	07.04-10.08		1,0	IFR5N10	7866		
Discovery 3	4.4		8	08.04-		1,0	IFR5N10	7866		
Discovery 5.0	L319	5.0	276	8	09.09-	508PN	1,0	ILKAR7C10	94940	

FREELANDER

Freelander	1.8	87	4	.97-	K SERIES	1,1	PFR6N-11	3546		LPG 1
Freelander	2.0		6	.01-	KV6	1,1	PFR6N-11	3546		LPG 1
Freelander V6	2.5	130	6	09.00-	KV6	1,1	PFR6N-11	3546		LPG 1

FREELANDER 2

Freelander 3.2 (Chassis No 7H038590→)	L359	3.2	171	6	10.06-10.14	32PDPR	0,8	ILFR6B	6481	
---------------------------------------	-------------	-----	-----	---	-------------	--------	-----	--------	------	--

RANGE ROVER

Range Rover Evoque 2.0	L538	2.0	177	4	06.11-	204PT	0,8	ILTR6G8G	96621	
Range Rover		4.0	131	8	01.99- .02		1,1	PFR6N-11	3546	LPG 1
Range Rover		4.0		8	09.94-12.98		0,8	BPR6ES	7822	2 LPG 2
Range Rover Sport 4.2 Supercharged		4.2	287	8	02.05-	AJ41	1,0	IFR5N10	7866	
Range Rover 4 4.2 Supercharged		4.2	291	8	05.05-	AJ41	1,0	IFR5N10	7866	
Range Rover		4.2		8	10.92-12.94	V8	0,8	BPR6ES	7822	2 LPG 2
Range Rover		4.4	210	8	09.99-	BMW M62 B44	1,5	BKR6EQUP	3199	30 LPG 1
Range Rover Sport 4.4		4.4	220	8	02.05-	AJ41	1,0	IFR5N10	7866	
Range Rover 4 4.4		4.4	225	8	05.05-	AJ41	1,0	IFR5N10	7866	
Range Rover		4.6	160	8	01.99-		1,1	PFR6N-11	3546	LPG 1
Range Rover		4.6	165	8	09.94-10.98	V8	0,8	BPR6ES	7822	2 LPG 2
Range Rover Sport 5.0		5.0	276	8	07.09-	AJ133	1,0	ILKAR7C10	94940	
Range Rover 4 5.0		5.0	276	8	09.09-	AJ133	1,0	ILKAR7C10	94940	
Range Rover Sport 5.0 Supercharged		5.0	372	8	01.10-	AJ133	1,0	ILKAR7C10	94940	
Range Rover 4 5.0 Supercharged		5.0	375	8	09.09-	AJ133	1,0	ILKAR7C10	94940	
Range Rover Sport 5.0 Supercharged		5.0	375	8	09.09-	AJ133	1,0	ILKAR7C10	94940	

RANGE ROVER 2

Range Rover Sport 5.0 SCV8 (Chassis No →HA999999)	L494	5.0	386	8	11.17-	508PS	1,0	ILKAR7C10	94940	
Range Rover Sport 5.0 SCV8 (Chassis No →HA999999)	L494	5.0	405	8	01.14-	508PS	1,0	ILKAR7C10	94940	
Range Rover Sport 5.0 SCV8 (Chassis No →HA999999)	L494	5.0	423	8	11.17-	508PS	1,0	ILKAR7C10	94940	

RANGE ROVER 4

Range Rover 5.0 V8	L405	5.0	276	8	12.13-	508PN	1,0	ILKAR7C10	94940	
Range Rover 5.0 SCV8	L405	5.0	375	8	08.12-	508PS	1,0	ILKAR7C10	94940	
Range Rover 5.0 SCV8 (Chassis No →HA999999)	L405	5.0	386	8	11.17-	508PS	1,0	ILKAR7C10	94940	
Range Rover 5.0 SCV8	L405	5.0	405	8	06.15-	508PS	1,0	ILKAR7C10	94940	
Range Rover 5.0 SCV8 (Chassis No →HA999999)	L405	5.0	416	8	11.17-	508PS	1,0	ILKAR7C10	94940	





l kW C
Y I



Stock-N°

VLINE

LPG/CNG

LEXUS

CT 200H

CT 200h Hybrid	ZWA10	1.8	73	4	12.10-	2ZR-FXE	1,1	ILKAR7B11	4912		
----------------	-------	-----	----	---	--------	---------	-----	-----------	------	--	--

ES 250

ES 250 2.5 VVTi	ASV60	2.5	135	4	06.12-06.18	2AR-FE	1,1	ILFR5T11	96779		ILFR6T11
-----------------	-------	-----	-----	---	-------------	--------	-----	----------	-------	--	----------

ES 300

ES 300	MCV20	3.0		6	01.00- .03	2JZ-GE	1,1	BKR6EKP-11	3452		
--------	-------	-----	--	---	------------	--------	-----	------------	------	--	--

ES 300	MCV30	3.0		6	01.04-	1MZFE	1,1	IFR6T11	4589		
--------	-------	-----	--	---	--------	-------	-----	---------	------	--	--

ES 350

ES 350 3.5 VVTi	GSV60	3.5	183	6	01.14-06.18	2GR-FE	1,1	DILFR6D11	6176		
-----------------	-------	-----	-----	---	-------------	--------	-----	-----------	------	--	--

ES 350 3.5 VVTi	GSV60	3.5	204	6	06.12-06.18	2GR-FE	1,1	DILFR6D11	6176		
-----------------	-------	-----	-----	---	-------------	--------	-----	-----------	------	--	--

GS 250

GS 250	GRL11	2.5	154	6	03.12-	4GR-FSE	1,1	DFH6B-11A	1501		
--------	-------	-----	-----	---	--------	---------	-----	-----------	------	--	--

GS 300

GS 300	JZS147	3.0	156	6	.93- .99	2JZ-GE	1,1	BKR5EP-11	3440		LPG 1
--------	--------	-----	-----	---	----------	--------	-----	-----------	------	--	-------

GS 300	JZS160, UZS161	3.0	161	6	01.02-	2JZ-GE	1,1	BKR6EP-11	2978		LPG 1
--------	-------------------	-----	-----	---	--------	--------	-----	-----------	------	--	-------

GS 300		3.0	163	6	.97-	2TZ-GE	1,1	BKR6EKP-11	3452		
--------	--	-----	-----	---	------	--------	-----	------------	------	--	--

GS 300	UZS190, GRS190	3.0	170	6	04.05-	3GR-FE	1,1	DFH6B-11A	1501		
--------	-------------------	-----	-----	---	--------	--------	-----	-----------	------	--	--

GS 300	UZS190, GRS190	3.0	183	6	04.05-08.07	3GR-FSE	1,1	DFH6B-11A	1501		
--------	-------------------	-----	-----	---	-------------	---------	-----	-----------	------	--	--

GS 300	UZS190, GRS190	3.0	183	6	09.07-	3GR-FSE	1,1	ILFR6T11	4904		
--------	-------------------	-----	-----	---	--------	---------	-----	----------	------	--	--

GS 300	JZS160	3.0		6	01.00-	1MZFE	1,1	BKR6EKP-11	3452		
--------	--------	-----	--	---	--------	-------	-----	------------	------	--	--

GS 300	UZS190, GRS190	3.0		6	05.05-	3GR-FSE	1,1	IFR6T11	4589		
--------	-------------------	-----	--	---	--------	---------	-----	---------	------	--	--

GS 350

GS 350 3.5 VVTi	GRS196	3.5	226	6	09.06-11.11	2GR-FSE	1,1	DFH6B-11A	1501		
-----------------	--------	-----	-----	---	-------------	---------	-----	-----------	------	--	--

GS 350 3.5 VVTi	GRL15	3.5	233	6	03.12-09.15	2GR-FSE	1,1	DFH6B-11A	1501		
-----------------	-------	-----	-----	---	-------------	---------	-----	-----------	------	--	--

GS 350 3.5 VVTi	GRL10	3.5	233	6	03.12-	2GR-FSE	1,1	DFH6B-11A	1501		
-----------------	-------	-----	-----	---	--------	---------	-----	-----------	------	--	--

GS 350 3.5 VVTi	GRL15, GRL16	3.5	234	6	12.11-09.15	2GR-FKS, 2GR-FSE	1,1	DFH6B-11A	1501		
-----------------	-----------------	-----	-----	---	-------------	------------------	-----	-----------	------	--	--

GS 350 3.5 VVTi	GRL10	3.5	234	6	03.12-	2GR-FSE	1,1	DFH6B-11A	1501		
-----------------	-------	-----	-----	---	--------	---------	-----	-----------	------	--	--

GS 430

GS 430	JZS160, UZS161	4.3	208	6	01.02-	3UZFE	1,1	IFR6T11	4589		
--------	-------------------	-----	-----	---	--------	-------	-----	---------	------	--	--

GS 430	GRS190	4.3	208	8	08.05-	3UZFE	1,1	IFR6T11	4589		
--------	--------	-----	-----	---	--------	-------	-----	---------	------	--	--

GS 430	UZS190	4.3	208	8	08.05-	3UZFE	1,1	IFR6T11	4589		
--------	--------	-----	-----	---	--------	-------	-----	---------	------	--	--

GS 450H

GS 450h Hybrid	GWS191	3.5	218	6	02.06-11.11	2GR-FSE	1,1	DFH6B-11A	1501		
----------------	--------	-----	-----	---	-------------	---------	-----	-----------	------	--	--

GS 450h Hybrid	GWS191	3.5	254	6	02.06-11.11	2GR-FSE	1,1	DFH6B-11A	1501		
----------------	--------	-----	-----	---	-------------	---------	-----	-----------	------	--	--

GS 460

GS 460	URS190	4.6	255	8	09.07-	1UR-FSE	1,1	DFH6B-11A	1501		
--------	--------	-----	-----	---	--------	---------	-----	-----------	------	--	--

IS 200

IS 200	GXE10	2.0	114	6	01.00-	1G-FE	1,1	IFR6T11	4589		
--------	-------	-----	-----	---	--------	-------	-----	---------	------	--	--

IS 250

IS 250	GSE20	2.5	153	6	08.05-04.13	4GR-FSE	1,1	DFH6B-11A	1501		
--------	-------	-----	-----	---	-------------	---------	-----	-----------	------	--	--

IS 250	GSE30	2.5	153	6	04.13-	4GR-FSE	1,1	DFH6B-11A	1501		
--------	-------	-----	-----	---	--------	---------	-----	-----------	------	--	--

IS 300

IS 300	GXE10, JCE10, JCE15	2.0	114	6	09.01-	1G-FE	1,1	IFR6T11	4589		
--------	---------------------------	-----	-----	---	--------	-------	-----	---------	------	--	--





kw
C
Y
I



Stock-Nº

VLINE

LPG/CNG

LEXUS

IS 300

IS 300	GXE10, JCE10, JCE15	3.0		6	01.02-	2JZ-GE	1,1	BKR6EP-11	2978		LPG 1
--------	---------------------------	-----	--	---	--------	--------	-----	-----------	------	--	-------

IS C

IS C	GSE20	2.5	153	6	04.09-	4GR-FSE	1,1	DFH6B-11A	1501		
------	-------	-----	-----	---	--------	---------	-----	-----------	------	--	--

IS I

IS 300 3.0 VVTi	JCE10	3.0	157	6	07.01-07.05	2JZ-GE	1,1	BKR6EIX-11P	2574		
IS 300 3.0 VVTi	JCE10	3.0	157	6	07.01-10.05	2JZ-GE	1,1	BKR6EIX-11P	2574		

IS II

IS 250 2.5 VVTi	GSE25	2.5	153	6	01.06-04.13	4GR-FSE	1,1	DFH6B-11A	1501		
-----------------	-------	-----	-----	---	-------------	---------	-----	-----------	------	--	--

IS-F

IS-F	USE20	5.0	311	8	11.07-	2UR-GSE	1,1	DFH6B-11A	1501		
------	-------	-----	-----	---	--------	---------	-----	-----------	------	--	--

LS 400

LS 400 (with TWC)		4.0	180	8	.90- .94	1UZ-FE	1,1	BKR6EP-11	2978		LPG 1
LS 400		4.0	194	8	10.94-12.99	1UZ-FE	0,8	BKR6EP-8	2215		LPG 1
LS 400 4.0	UCF20	4.0	194	8	10.94-12.97	1UZ-FE	1,1	BKR6EP-11	2978		LPG 1
LS 400 4.0	UCF20	4.0	216	8	10.97-07.00	1UZ-FE	1,1	IFR6T11	4589		
LS 400		4.0		8	06.90-06.97	1UAZ-FE	1,1	BKR5EP-11	3440		LPG 1
LS 400	UCF20	4.0		8	01.00-	1UZ-FE	1,1	IFR6T11	4589		

LS 430

LS 430 (with TWC)	UCF30	4.3	207	8	08.00-	3UZ-FE	1,1	IFR6T11	4589		
LS 430 (without TWC)	UCF30	4.3		8	08.00-	3UZ-FE	0,8	BKR6EYA	2249		LPG 1

LS 460

LS 460	USF40, USF41	4.6	255	8	09.06-	1UR-FE	1,1	ILFR6T11	4904		
LS 460 AWD	USF45, USF46	4.6	270	8	12.08-	1UR-FSE	1,1	DFH6B-11A	1501		
LS 460 4.6 VVTi	USF45	4.6	272	8	09.12-	1UR-FSE	1,1	DFH6B-11A	1501		
LS 460	USF40, USF41	4.6	280	8	04.06-	1UR-FSE	1,1	DFH6B-11A	1501		
LS 460 4.6 VVTi	USF46	4.6	280	8	08.06-	1UR-FSE	1,1	DFH6B-11A	1501		
LS 460	USF46	4.6	280	8	12.08-	1UR-FSE	1,1	DFH6B-11A	1501		
LS 460 4.6 VVTi	USF40, USF41	4.6	285	8	09.12-	1UR-FSE	1,1	DFH6B-11A	1501		

LS 600H

LS 600h 5.0 VVTi Hybrid	UVF45	5.0	272	8	07.12-	2UR-FSE	1,1	DFH6B-11A	1501		
LS 600h Hybrid	UVF45, UVF46	5.0	290	8	04.07-	2UR-FSE	1,1	DFH6B-11A	1501		
LS 600h 5.0 VVTi Hybrid	UVF45, UVF46	5.0	290	8	04.07-	2UR-FSE	1,1	DFH6B-11A	1501		

LX 470

LX 470 (without TWC)	UZJ100	4.7		8	01.00-	2UZ-FE	0,8	BKR6EYA	2249		LPG 1
LX 470 (with TWC)	UZJ100	4.7		8	01.00-	2UZ-FE	1,1	IFR6T11	4589		

LX 570

LX 570 5.7 VVTi	URJ201	5.7	270	8	04.08-	3UR-FE	1,1	ILFR6T11	4904		
LX 570 5.7 VVTi	URJ201	5.7	282	8	11.07-	3UR-FE	1,1	ILFR6T11	4904		
LX 570 5.7 VVTi	URJ201	5.7	285	8	08.07-	3UR-FE	1,1	ILFR6T11	4904		

NX 200

NX 200 2.0	ZGZ10, ZGZ15	2.0	110	4	07.14-	3ZR-FAE	1,1	DF6H-11B	5989		
NX 200 2.0	ZGZ10	2.0	110	4	07.14-	3ZR-FAE	1,1	ILKAR7B11	4912		





l kW C
Y
I



Stock-N°

VLINE

LPG/CNG

LEXUS

NX 200										
NX 200 2.0	ZGZ15	2.0	110	4	11.14-	3ZR-FAE	1,1	ILKAR7B11	4912	
RC 350										
RC 350 3.5	GSC10	3.5	234	6	09.14-	2GR-FSE	1,1	DFH6B-11A	1501	
RX 270										
RX 270 2.7 VVTi	AGL10	2.7	138	4	08.10-09.15	1AR-FE	1,1	ILFR5T11	96779	ILFR6T11
RX 300										
RX 300	MCU10	3.0	148	6	01.98-02.03	1MZFE	1,1	IFR6T11	4589	
RX 300	MCU15	3.0	150	6	07.00-.06	1MZFE	1,1	IFR6T11	4589	
RX 300	MCU35, MCU38	3.0		6	01.04-.06	1MZFE	1,1	IFR6T11	4589	
RX 300	MCU35, MCU38	3.3		6	01.04-.06	3MZFE	1,1	IFR6T11	4589	
RX 330										
RX 330	MCU35, MCU38	3.0		6	01.04-	1MZFE	1,1	IFR6T11	4589	
RX 330	MCU35, MCU38	3.3	171	6	04.03-01.06	3MZFE	1,1	IFR6T11	4589	
RX 350										
RX 350 3.5 VVTi	GGL10	3.5	202	6	01.09-09.15	2GR-FE	1,1	DILFR6D11	6176	
RX 350 3.5	GSU35	3.5	203	6	02.06-06.09	2GR-FE	1,1	DILFR6D11	6176	
RX 350 3.5 VVTi	GGL15	3.5	204	6	01.09-09.15	2GR-FE	1,1	DILFR6D11	6176	
RX 400H										
RX 400h Hybrid	MHU38	3.3	155	6	03.05-	3MZFE	1,1	IFR6T11	4589	
RX 450H										
RX 450h 3.5 Hybrid	GYL10	3.5	183	6	12.08-09.15	2GR-FXE	1,1	DILFR6D11	6176	
RX 450h 3.5 Hybrid	GYL15	3.5	183	6	01.09-09.15	2GR-FXE	1,1	DILFR6D11	6176	
SC 430										
SC 430	UZZ40	4.3	210	8	05.01-	3UZFE	1,1	IFR6T11	4589	

LOTUS

ELAN										
Elan SE 16V Turbo		1.6		4	10.89-		0,8	BKR6E	6962	28 LPG 1
Elan 1.6 16V		1.6		4	10.89-		1,1	BKR6E-11	2756	14 LPG 1
ELISE										
Elise		1.8	88	4	.96-	K-SERIES (Including) VVC	1,1	PFR6N-11	3546	LPG 1
Elise 111S		1.8	107	4	.99-		1,1	PFR6N-11	3546	LPG 1
ESPRIT										
Esprit 2.0 Turbo 16V GT3		2.0		4	10.96-		0,8	BPR6EKN	1128	
Esprit Turbo SE		2.2	197	4	.89-	910S	0,6	BPR6EKN	1128	
Esprit HC		2.2		4	.85-		0,8	BPR7ES	2023	19 BPR8EIX
Esprit Turbo		2.2		4	.87-		0,8	BPR6ES	7822	2 LPG 2
Esprit S4		2.2		4	.93-07.96		0,6	BPR6EKN	1128	
Esprit Sport 300		2.2		4	.93-		0,6	BPR6EKN	1128	
Esprit SE 2.2		2.2		4	11.94-07.96	Cat.	0,8	BPR6EKN	1128	
EXCEL										
Excel SA / SE		2.2	135	4	.85-.91	912S	0,8	BPR7ES	2023	19 BPR8EIX
EXIGE										
Exige 1.8 16V		1.8	132	4	07.00-		0,8	BKR7E	6097	BKR8EIX



e kW C
Y
I

Stock-N°

VLINE

LPG/CNG

MASERATI**2.24 V**

2.24 V	2.0	180	4	.88-	AM 475	0,9	DCPR8E	4339		LPG 8
--------	-----	-----	---	------	--------	-----	--------	------	--	-------

228 I

228 I	2.8	184	6	12.87-	Bi Turbo Cat.	0,8	BP8ES	2912		BPR9EIX
-------	-----	-----	---	--------	---------------	-----	-------	------	--	---------

3200 GT

3200 GT	3.2	271	8	12.98-09.01		0,7	PMR8A	5851		
---------	-----	-----	---	-------------	--	-----	-------	------	--	--

4.18 V

4.18 V	2.0		6	02.91-		0,8	BP8ES	2912		BPR9EIX
--------	-----	--	---	--------	--	-----	-------	------	--	---------

4.24 V

4.24 V / Spider 24V	2.0	180	6	.90-		0,9	DCPR8E	4339		LPG 8
---------------------	-----	-----	---	------	--	-----	--------	------	--	-------

420

420 / I / S / SI /	2.0	138	6	01.87-		0,8	BP8ES	2912		BPR9EIX
--------------------	-----	-----	---	--------	--	-----	-------	------	--	---------

422

422	2.0	164	6	.88-	AM 471	0,8	BP8ES	2912		BPR9EIX
-----	-----	-----	---	------	--------	-----	-------	------	--	---------

430

430	2.8	182	6	02.88-	473 Cat.	0,8	BP8ES	2912		BPR9EIX
-----	-----	-----	---	--------	----------	-----	-------	------	--	---------

COUPÉ

Coupe GT / Cambiocorsa	4.2	287	8	06.02-11.03	F136R	0,7	PMR8A	5851		
------------------------	-----	-----	---	-------------	-------	-----	-------	------	--	--

Coupe GT / Cambiocorsa	4.2	287	8	12.03-	F136R	0,7	PMR8B	6378		
------------------------	-----	-----	---	--------	-------	-----	-------	------	--	--

GHIBLI

Ghibli	2.0	209	6	09.96-		0,7	DCPR9E	2641		
--------	-----	-----	---	--------	--	-----	--------	------	--	--

Ghibli 3.0	M157	3.0	243	6	08.13-	M156C	0,6	SILKAR8C6DS	96372	
------------	------	-----	-----	---	--------	-------	-----	-------------	-------	--

Ghibli 3.0	M157	3.0	257	6	01.14-	M156C	0,6	SILKAR8C6DS	96372	
------------	------	-----	-----	---	--------	-------	-----	-------------	-------	--

Ghibli 3.0 S	M157	3.0	301	6	08.13-	M156B	0,6	SILKAR8C6DS	96372	
--------------	------	-----	-----	---	--------	-------	-----	-------------	-------	--

GHIBLI V6

Ghibli V6	2.8	209	6	11.95-		0,8	DCPR9E	2641		
-----------	-----	-----	---	--------	--	-----	--------	------	--	--

GRAN TURISMO

Gran Turismo 4.2 V8	4.2	298	8	08.08-	M139P, F136UD	0,7	PMR8C-H	96361		
---------------------	-----	-----	---	--------	---------------	-----	---------	-------	--	--

Gran Turismo 4.7 V8 S	4.7	323	8	08.08-12.12	M139S, F136YE	0,7	PMR8C-H	96361		
-----------------------	-----	-----	---	-------------	---------------	-----	---------	-------	--	--

Gran Turismo 4.2 V8	4.7	331	8	01.11-	M145T	0,7	PMR8C-H	96361		
---------------------	-----	-----	---	--------	-------	-----	---------	-------	--	--

GRANCABRIO

GranCabrio 4.7 V8	4.7	323	8	06.10-01.13	M139S	0,7	PMR8C-H	96361		
-------------------	-----	-----	---	-------------	-------	-----	---------	-------	--	--

GranCabrio 4.7 V8	4.7	331	8	01.11-	M145T	0,7	PMR8C-H	96361		
-------------------	-----	-----	---	--------	-------	-----	---------	-------	--	--

GRANSPORT

GranSport 4.3	4.3	295	8	06.03-12.06	AM138P, F136S	0,7	PMR8B	6378		
---------------	-----	-----	---	-------------	---------------	-----	-------	------	--	--

KARIF

Karif	2.8	165	6	04.88-	437 Cat.	0,8	BP8ES	2912		BPR9EIX
-------	-----	-----	---	--------	----------	-----	-------	------	--	---------

LEVANTE

Levante 3.0	LEV	3.0	257	6	06.16-	M156D	0,6	SILKAR8C6DS	96372	
-------------	-----	-----	-----	---	--------	-------	-----	-------------	-------	--

Levante 3.0 S	LEV	3.0	316	6	06.16-	M156E	0,6	SILKAR8C6DS	96372	
---------------	-----	-----	-----	---	--------	-------	-----	-------------	-------	--

QUATTROPORTE

Quattroporte 4.2	4.2	294	8	11.02-11.03		0,7	PMR8A	5851		
------------------	-----	-----	---	-------------	--	-----	-------	------	--	--

Quattroporte 4.2	4.2	294	8	12.03-	F136S	0,7	PMR8B	6378		
------------------	-----	-----	---	--------	-------	-----	-------	------	--	--

QUATTROPORTE II

Quattroporte II 2.0 V6 Biturbo	2.0	211	6	03.94- .99		0,6	DCPR9E	2641		
--------------------------------	-----	-----	---	------------	--	-----	--------	------	--	--

Quattroporte II 2.8 V6 Biturbo	2.8	209	6	11.95-01.99		0,8	DCPR9E	2641		
--------------------------------	-----	-----	---	-------------	--	-----	--------	------	--	--





e kW C
Y
I



Stock-N°

VLINE

LPG/CNG

MASERATI

QUATTROPORTE II

Quattroporte II 2.8 V6 Evoluzione	2.8	260	6	02.99-12.01		0,9	DCPR8E	4339		LPG 8
Quattroporte II 3.2 V8 Evoluzione	3.2	270	8	02.99- .02		0,7	PMR8A	5851		

QUATTROPORTE III

Quattroporte III 4.2 V8	4.2	295	8	09.03-12.12	M139A	0,7	PMR8C-H	96361		
Quattroporte III 4.7 S	4.7	317	8	06.08-12.12	M139R, F136YG	0,7	PMR8C-H	96361		
Quattroporte III 4.7 GT S	4.7	323	8	06.08-12.12	M139S	0,7	PMR8C-H	96361		
Quattroporte III 4.7 GT S	4.7	331	8	01.10-12.12	M145T	0,7	PMR8C-H	96361		

QUATTROPORTE IV

Quattroporte 3.0	M156	3.0	243	6	03.13-	M156C	0,6	SILKAR8C6DS	96372	
Quattroporte 3.0	M156	3.0	257	6	06.16-	M156C	0,6	SILKAR8C6DS	96372	
Quattroporte 3.0 S	M156	3.0	301	6	05.13-	M156B	0,6	SILKAR8C6DS	96372	
Quattroporte 3.8 GT S	M156	3.8	390	8	01.13-	M156A	0,6	SILKAR8C6DS	96372	

RACING

Racing	2.0	194	6	02.91-		0,7	DCPR9E	2641		
--------	-----	-----	---	--------	--	-----	--------	------	--	--

SHAMAL

Shamal I Turbo 32V	3.2	240	8	02.91-02.96	AM 479 Cat.	0,9	DCPR8E	4339		LPG 8
--------------------	-----	-----	---	-------------	-------------	-----	--------	------	--	-------

SPYDER

Spyder	2.8	165	6	01.90-	473 Cat.	0,8	BP8ES	2912		BPR9EIX
Spyder GT/Cambiocorsa	4.2	287	8	10.01-11.03	F136R	0,7	PMR8A	5851		
Spyder GT/Cambiocorsa	4.2	287	8	12.03-	F136R	0,7	PMR8B	6378		

MAYBACH

MAYBACH (240)

Maybach 57/ 62 (240)	5.5	404	12	09.02-	M 285.950	0,8	IFR6Q-G	5648		
Maybach 62S (240)	6.0	450	12	09.05-	M 285.980	0,8	IFR6Q-G	5648		

MAZDA

121

121 1.1	DB1	1.1	40	4	11.90-10.93	B121	0,9	BPR5ES	7422		LPG 2
121 1.1	DB1	1.1	40	4	11.90-10.93	B121	0,8	BPR6ES	7822		LPG 2
121 DA (VIN→200000)		1.1	40	4	-03.91	B1 u.Cat.	0,9	BPR5ES	7422	6	LPG 2
121 16V		1.25	55	4	.00- .02	DHB, DHC, DHD, DHF	1,3	PTR5A-13	2467	25	LPG 4
121 ZQ		1.3	37	4	03.96-	JJA, JJC, JJE, J4C	1,0	PTR5D-10	3784	31	LPG 5
121 1.3	DB1	1.3	39	4	11.90-03.96	B3C9	1,1	BKR5E-11	6953	33	LPG 1
121 DB (VIN→400000)		1.3	39	4	- .96	B3 16V Cat.	1,1	BKR6E-11	2756	14	LPG 1
121 DA (VIN 200001→)		1.3	40	4	- .96	B3 Cat.	1,1	BPR6ES-11	4824	13	LPG 2
121 DA (VIN→200000)		1.3	44	4	03.96-	B3	0,9	BPR5ES	7422	6	LPG 2
121 1.3	DB1	1.3	53	4	11.90-03.96	B3C9	1,1	BKR5E-11	6953	33	LPG 1
121 DB (VIN 400000→)		1.3	53	4	- .96	B3 16V Cat.	1,1	BKR6E-11	2756	14	LPG 1
121 ZQ		1.3	55	4	03.96-	DHA Zetec (FORD)	1,3	PTR5A-13	2467	25	LPG 4

2

2 DY (VIN 3*00001→)		1.25	55	4	.03- .07	MZI FUJA, F8JB, MZI FUJB, F8JA	1,3	PTR5A-13	2467	25	LPG 4
2 1.3 (DE)		1.3	55	4	10.07-	ZJ-VE, FUJA	1,3	IFR5E13	6903		IFR6E11
2 DY (VIN 3*00001→)		1.3	59	4	.03- .07	MZI DOHC FXJA, FXJB	1,3	PTR5A-13	2467	25	LPG 4
2 1.3 (DE)		1.3	63	4	10.07-	ZJ-VEM, FXJA	1,3	IFR5E13	6903		IFR6E11
2 1.5 (DE)		1.5	76	4	10.07-	ZY-VE, FYJA	1,3	IFR5E13	6903		IFR6E11





l kW C
Y I



Stock-N°

VLINE

LPG/CNG

MAZDA

2											
2 DY (VIN 3*00001→)		1.6	74	4	.03- .07	MZI DOHC FYJA	1,3	PTR5A-13	2467	25	LPG 4
3											
3 1.4	BK	1.4	59	4	.04- .09	ZJ	1,1	BKR5E-11	6953	33	LPG 1
3 1.4	BK	1.4	62	4	10.03-03.06	ZJ07	1,1	BKR5E-11	6953	33	LPG 1
3 1.5 Skyactiv-G 100	BM	1.5	74	4	07.13-	P5Y1	1,1	ILKAR7L11	94124		
3 1.6	BK	1.6	77	4	10.03-	CE	1,1	BKR5E-11	6953	33	LPG 1
3 1.6	BK	1.6	77	4	10.03- .09	Z601, Z627	1,1	BKR5E-11	6953	33	LPG 1
3 1.6 MZR	BL	1.6	77	4	06.09-	Z668	1,3	IFR5E13	6903		IFR6E11
3 2.0 Skyactiv-G 120	BM	2.0	88	4	07.13-	PEY7	1,1	ILKAR7L11	94124		
3 2.0 Check the spark plug on the vehicle!	BK	2.0	110	4	10.03-01.04	LF17, LF50, LF72, LFN7, LFN8	1,3	ILTR5A-13G	3811		ILTR6A-13G
3 2.0 Check the spark plug on the vehicle!	BK	2.0	110	4	10.03-01.04	LF17, LF50, LF72, LFN7, LFN8	1,3	ITR6F13	4477		LPG 5
3 2.0 Check the spark plug on the vehicle!	BK	2.0	110	4	02.04-12.09	LF17, LF50, LF72, LFN7, LFN8	1,3	TR5AI-13	90813		LPG 5
3 2.0 MZR	BL	2.0	110	4	02.09-	LF5H, LF5W, LFZ2	1,3	ILTR5A-13G	3811		ILTR6A-13G
3 2.0 MZR DISI	BL	2.0	111	4	02.09-	LF5H, LF5W, LFZ2	1,3	ILTR5A-13G	3811		ILTR6A-13G
3 2.0 Skyactiv-G 165 i-ELOOP	BM	2.0	121	4	07.13-	PEY7	1,1	ILKAR7L11	94124		
3 2.3 MPS	BK	2.3	191	4	06.06-01.09	L3M6	0,8	ILTR6A-8G	3787		
3 2.3 MPS Turbo	BL	2.3	191	4	05.09-	L3Y7	0,7	SILTR6A7G	95369		
323											
323 1.3	BJ12	1.3	53	4	01.01-05.04	B35S	1,1	BKR6E-11	2756	14	LPG 1
323F 1.3	BJ14	1.3	53	4	01.01-05.04	B35S	1,1	BKR6E-11	2756	14	LPG 1
323 1.3	BA1	1.3	54	4	08.94-09.98	B32A, B3P7	1,1	BKR5E-11	6953	33	LPG 1
323C 1.3	BA1	1.3	54	4	08.94-09.98	B3P7	1,1	BKR5E-11	6953	33	LPG 1
323P 1.3	BA1	1.3	54	4	11.96-10.99	B32A	1,1	BKR5E-11	6953	33	LPG 1
323 1.3	BJ12	1.3	54	4	09.98-01.01	B33G	1,1	BKR6E-11	2756	14	LPG 1
323F 1.3	BJ14	1.3	54	4	09.98-01.01	B33G	1,1	BKR6E-11	2756	14	LPG 1
323 (BG)		1.3		4	.90-	B3 Vergaser	0,8	BKR5E	7938	35	LPG 1
323 (BJ) (VIN 400001→)		1.4	53	4	.02-	B3 SOHC	1,1	BKR5E-11	6953	33	LPG 1
323 (BA) (VIN 300001→)		1.4	54	4	09.94-	B3	1,1	BKR6E-11	2756	14	LPG 1
323 (BJ) (VIN 100001→)		1.4	54	4	09.98-	B3	1,1	BKR5E-11	6953	33	LPG 1
323 1.5	BA1	1.5	65	4	08.94-09.98	Z501	1,1	BKR5E-11	6953	33	LPG 1
323C 1.5	BA1	1.5	65	4	08.94-09.98	Z501	1,1	BKR5E-11	6953	33	LPG 1
323 (BA) (VIN 100001→)		1.5	65	4	09.94-	Z5 Cat.	1,1	BKR5E-11	6953	33	LPG 1
323P 1.5	BA1	1.5	65	4	11.96-07.01	Z501	1,1	BKR6E-11	2756	14	LPG 1
323 (BJ) (VIN 100001→)		1.5	65	4	09.98-	ZL	1,1	BKR5E-11	6953	33	LPG 1
323 1.5 -/VVT	BJ12	1.5	65	4	09.98-01.01	ZL05, ZL06	1,1	BKR6E-11	2756	14	LPG 1
323F 1.5 -/VVT	BJ14	1.5	65	4	09.98-01.01	ZL05, ZL06	1,1	BKR6E-11	2756	14	LPG 1
323 (BF1) (VIN 400001→)		1.6	103	4	.85- .91	B6 DOHC Cat.	1,1	BCPR6E-11	3132	11	LPG 3
323 1.8	BA1	1.8	84	4	08.94-09.98	BP3G, BP3H, BPE4, BPE5	1,1	BKR5E-11	6953	33	LPG 1
323C 1.8	BA1	1.8	84	4	08.94-09.98	BP3G, BP3H, BPE4, BPE5	1,1	BKR5E-11	6953	33	LPG 1
323		1.8	84	4	02.97-	B6D	1,1	BKR5E-11	6953	33	LPG 1
323 1.8	BJ12	1.8	84	4	09.98-05.04	FP55	1,1	BKR5E-11	6953	33	LPG 1
323F 1.8	BJ14	1.8	84	4	09.98-07.01	FP55	1,1	BKR6E-11	2756	14	LPG 1
323 1.8	BJ12	1.8	92	4	05.98-05.04	FP55	1,1	BKR5E-11	6953	33	LPG 1
323 1.8	BJ12	1.8	92	4	05.98-05.04	FP55	1,1	BKR6E-11	2756	14	LPG 1





l kW C
Y
I



Stock-N°

VLINE

LPG/CNG

MAZDA

323

323 GTR Turbo		1.8	136	4	.95-		1,1	BKR6EIX-11	3764		LPG 1
323		1.8		4	.89-	BP EGI Cat.	0,8	BKR5E	7938	35	LPG 1
323		1.8		4	.89-	BP DOHC Cat.	1,1	BKR6E-11	2756	14	LPG 1
323 Turbo		1.8		4	.89-	BP	1,1	BKR6E-11	2756	14	LPG 1
323 (BA) (VIN 300001→)		1.9	84	4	09.94-	BP 16V Cat.	1,1	BKR5E-11	6953	33	LPG 1
323 (BJ) (VIN 100001→)		1.9	84	4	09.98-	FP	1,1	BKR5E-11	6953	33	LPG 1
323 2.0	BJ12	2.0	96	4	10.00-10.03	FS7E, FS7G	1,1	ZFR6F-11	4291		LPG 6
323F 2.0	BJ14	2.0	96	4	01.01-05.04	FS7E, FS7G	1,1	ZFR6F-11	4291		LPG 6
323 (BJ) (VIN 400001→)		2.0	96	4	.02- .04	FS7G, FS7E DOHC (High Power)	1,1	ZFR5F-11	2262	40	LPG6
323 (BA) (VIN 500001→)		2.0	106	6	08.94-10.98	KF DOHC V6	1,1	BKR6E-11	2756	14	LPG 1
323 (BA) (VIN 100001→)		2.0	106	6	09.94-10.98	KF DOHC V6	1,1	BKR6E-11	2756	14	LPG 1
323F 2.0	BA1	2.0	106	6	01.95-07.98	KF52	1,1	BKR7E-11	1283		

5

5 (CR19)	CR19	1.8	85	4	06.05-	L8	1,3	TR5AI-13	90813		LPG 5
5 1.8 Check the spark plug on the vehicle!	CW19	1.8	85	4	06.10-	L850	1,3	ILTR6A-13G	3789		
5 1.8 Check the spark plug on the vehicle!	CW19	1.8	85	4	06.10-	L850	1,3	TR5AI-13	90813		LPG 5
5 2.0 Check the spark plug on the vehicle!	CW19	2.0	106	4	06.10-	LFZB	1,3	ILTR6A-13G	3789		
5 2.0 Check the spark plug on the vehicle!	CW19	2.0	106	4	06.10-	LFZB	1,3	TR5AI-13	90813		LPG 5
5 (CR19)	CR19	2.0	107	4	03.05-05.10	LFF7	1,3	TR5AI-13	90813		LPG 5
5 2.0 Check the spark plug on the vehicle!	CW19	2.0	110	4	06.10-	LF5H	1,3	ILTR6A-13G	3789		
5 2.0 Check the spark plug on the vehicle!	CW19	2.0	110	4	06.10-	LF5H	1,3	TR5AI-13	90813		LPG 5
5 (CR19)	CR19	2.3		4	.05-	L3-VE	1,3	TR5AI-13	90813		LPG 5

6

6 (GG) (VIN 100001→)		1.8	88	4	06.02- .07	MZR-L8 DOHC	1,3	ITR6F13	4477		LPG 5
6 Sport-Kombi (GY) (VIN 100001→)		1.8	88	4	06.02- .07	MZR-L8 DOHC	1,3	ITR6F13	4477		LPG 5
6 1.8	GG14, GG12	1.8	88	4	06.02-09.07	L813, L829	1,3	TR5AI-13	90813		LPG 5
6 Estate/Wagon 1.8	GY19	1.8	88	4	06.02-01.08	L813, L829	1,3	TR5AI-13	90813		LPG 5
6 1.8 MZR	GHA4, GHA2	1.8	88	4	08.07-07.13	L823	1,3	BPR5EFS-13	2359		
6		1.8	88	4	09.07-	L823	1,3	TR5AI-13	90813		LPG 5
6 2.0 (GG) Check the spark plug on the vehicle!	GG	2.0	104	4	06.02-09.07	LF17, LF18	1,3	ILTR5A-13G	3811		ILTR6A-13G
6 2.0 Sport-Kombi (GY) (VIN 100001→)	GY	2.0	104	4	06.02-02.05	LF17, LF18	1,3	ILTR5A-13G	3811		ILTR6A-13G
6 2.0 (GG) Check the spark plug on the vehicle!	GG	2.0	104	4	06.02-09.07	LF17, LF18	1,3	ITR6F13	4477		LPG 5
6 2.0 Sport-Kombi (GY) (VIN 100001→)	GY	2.0	104	4	06.02-02.05	LF17, LF18	1,3	ITR6F13	4477		LPG 5
6 2.0 Skyactiv-G 145	GJ2, GJ9	2.0	107	4	10.12-	PEY7	1,1	ILKAR7L11	94124		
6 2.0 Sport-Kombi (GY)	GY	2.0	108		03.05-01.08	LFH1, LFF7	1,3	ILTR5A-13G	3811		ILTR6A-13G
6 2.0 (GG) Check the spark plug on the vehicle!	GG	2.0	108	4	03.05-09.07	LFH1, LFF7	1,3	ILTR5A-13G	3811		ILTR6A-13G
6 2.0 (GG) Check the spark plug on the vehicle!	GG	2.0	108	4	03.05-09.07	LFH1, LFF7	1,3	ITR6F13	4477		LPG 5
6 2.0 (GH)	GH	2.0	108	4	08.07-	L17, LF95	1,3	ILTR5A-13G	3811		ILTR6A-13G
6 2.0	GHA2	2.0	108	4	08.07-12.12	LF4J, LFYA, LFYB	1,3	TR5B-13	4559	45	LPG 4
6 2.0	GHA4	2.0	108	4	08.07-07.13	LF95	1,3	TR5B-13	4559	45	LPG 4
6		2.0	108	4	09.07-		1,3	ITR6F13	4477		LPG 5
6 Estate/Wagon 2.0	GH19	2.0	108	4	12.07-07.13	LF95	1,3	TR5B-13	4559	45	LPG 4
6 2.0 Skyactiv-G 165	GJ2, GJ9	2.0	121	4	10.12-	PEY7	1,1	ILKAR7L11	94124		
6		2.0		4	06.05-	LF-VE	1,3	ILTR5A-13G	3811		ILTR6A-13G





l kW C
Y
I



Stock-N°

VLINE

LPG/CNG

MAZDA

6											
6 Sport-Kombi 4WD (GY) (VIN 100001→)		2.3	119	4	06.02- .07	MZR-L3 DOHC	1,3	ITR6F13	4477		LPG 5
6	GY89	2.3	119	4	11.02-02.05	L33	1,3	ILTR5A-13G	3811		ILTR6A-13G
6 2.3	GG12	2.3	120	4	03.05-07.07	L3C7	1,3	TR5B-13	4559	45	LPG 4
6 (GG) (VIN 100001→)		2.3	122	4	06.02- .07	MZR-L3 DOHC	1,3	ITR6F13	4477		LPG 5
6 Sport-Kombi (GY) (VIN 100001→)		2.3	122	4	06.02- .07	MZR-L3 DOHC	1,3	ITR6F13	4477		LPG 5
6		2.3	122	4	06.05-	L3C1	1,3	ILTR5A-13G	3811		ILTR6A-13G
6 2.3 MPS Turbo		2.3	191	4	03.05-02.08	L3C1	1,3	ILTR5A-13G	3811		ILTR6A-13G
6 2.5	GHA2	2.5	125	4	08.07-07.13	L501	1,3	TR5B-13	4559	45	LPG 4
6 Estate/Wagon 2.5	GH19	2.5	125	4	12.07-07.13	L501	1,3	TR5B-13	4559	45	LPG 4
6 2.5 Skyactiv-G 192 i-ELOOP	GJ2, GJ9	2.5	141	4	10.12-	PYY1	1,1	ILKAR7L11	94124		

626											
626		1.8	66	4	.90-	F8, F8 Cat.	1,1	BKR6E-11	2756	14	LPG 1
626 1.8 (Not for cold climate zones)	GF14	1.8	66	4	05.97-12.99	FP33	0,8	PZFR5F	3741		LPG 6
626 (GF) (VIN 100001→)		1.8	66	4	07.97-	FP DOHC	0,8	PZFR6F	7550		LPG 6
626 Estate/Wagon 1.8	GW19	1.8	66	4	02.98-01.00	FP33, FP63	0,8	PZFR5F	3741		LPG 6
626 1.8 (Not for cold climate zones)	GF14	1.8	74	4	08.99-04.02	FPA1	0,8	PZFR5F	3741		LPG 6
626 Estate/Wagon 1.8	GW19, GW69	1.8	74	4	10.99-04.02	FPA1	0,8	PZFR5F	3741		LPG 6
626 (GE) (VIN 434202→)		1.9	66	4	09.94-	FP DOHC	1,1	BKR6E-11	2756	14	LPG 1
626 (GF)		1.9	66	4	07.97-	FP	0,8	PZFR6F	7550		LPG 6
626 (GF) (VIN 400001→)		1.9	74	4	.00-	FP DOHC	0,8	PZFR6F	7550		LPG 6
626 (GW) (VIN 208843→)		1.9	74	4	.00-	FP DOHC	0,8	PZFR6F	7550		LPG 6
626 (GE) (VIN 100001→)		1.9	77	4	.92-	FP DOHC Cat.	1,1	BKR6E-11	2756	14	LPG 1
626 GE (VIN 802219→; For USA)		2.0	85	4	.92- .98	FS DOHC	1,1	BKR5E-11	6953	33	LPG 1
626 (GE) (VIN 4343202→)		2.0	85	4	.94-	FS DOHC Cat.	1,1	BKR6E-11	2756	14	LPG 1
626 2.0 (Not for cold climate zones)	GF14	2.0	85	4	07.97-04.02	FS2A, FS2B, FSJ2	0,8	PZFR5F	3741		LPG 6
626 Estate/Wagon 2.0	GW19, GW69	2.0	85	4	10.97-10.02	FS2A, FSJ2, FSS9	0,8	PZFR5F	3741		LPG 6
626 (GF) (VIN 400001→)		2.0	85	4	.00-	FS DOHC	0,8	PZFR6F	7550		LPG 6
626 (GW) (VIN 200001→)		2.0	85	4	.00-	FS DOHC	0,8	PZFR6F	7550		LPG 6
626 (GF)		2.0	100	4	07.97-	FS	0,8	PZFR6F	7550		LPG 6
626 Estate/Wagon 2.0	GW19, GW69	2.0	100	4	10.97-10.02	FS2C, FSH9, FSJ1	0,8	PZFR5F	3741		LPG 6
626 2.0 (Not for cold climate zones)	GF14	2.0	100	4	02.98-10.02	FS2C, FS2D, FSH9, FSJ1, FSJ4	0,8	PZFR5F	3741		LPG 6
626 2.0 (Not for cold climate zones)	GF12	2.0	100	4	04.98-10.02	FS2C, FS2D	0,8	PZFR5F	3741		LPG 6
626 2.0	GF12	2.0	100	4	04.98-10.02	FS2C, FS2D	0,8	PZFR5F	3741		LPG 6
626 (GF) (VIN 400001→)		2.0	100	4	.00-	FS DOHC High Power	0,8	PZFR6F	7550		LPG 6
626 (GW) (VIN 208843→)		2.0	100	4	.00-	FS DOHC High Power	0,8	PZFR6F	7550		LPG 6
626 (GE) (VIN 434202→)		2.5	120	6	09.94-	KL DOHC V6	1,1	ZFR5F-11	2262	40	LPG 6
626 (GE) (VIN 100001→)		2.5	121	6	.92- .94	KL DOHC V6 Cat.	1,1	ZFR6F-11	4291		LPG 6

B 2200											
B2200 2.2	UN8	2.2	60	4	02.99-10.99	F5A2	1,1	BPR5ES-11	4424		LPG 2
B2200 2.2	UN8	2.2	60	4	02.99-10.99	F5A2	1,1	BPR6ES-11	4824	13	LPG 2
B2200 2.2	UN1	2.2	68	4	02.99-08.02	F2R4	1,1	BPR5ES-11	4424		LPG 2
B2200 2.2	UN1	2.2	68	4	02.99-08.02	F2R4	1,1	BPR6ES-11	4824	13	LPG 2
B2200 2.2	UN8	2.2	68	4	06.99-08.02	F2R4	1,1	BPR5ES-11	4424		LPG 2
B2200 2.2	UN8	2.2	68	4	06.99-08.02	F2R4	1,1	BPR6ES-11	4824	13	LPG 2
B 2200		2.2		4	.90-	F2	0,9	BPR5ES	7422	6	LPG 2





l kW C
Y I



Stock-N°

VLINE

LPG/CNG

MAZDA

B 2200											
B 2200		2.2		4	.90-	F2 EGI	1,1	BPR5ES-11	4424		LPG 2
B 2600											
B2600 2.6	UN8	2.6	90	4	02.99-07.02	G6T1, R585	1,1	ZFR6F-11	4291		LPG 6
B 2600		2.6		6	.90-	G6	1,1	ZFR5F-11	2262	40	LPG6
CX-5											
CX5 2.0	KE89, KEK9	2.0	110	4	02.12-02.17	PEY5	1,1	ILKAR7L11	94124		
CX-5 2.0	KE	2.0	113	4	11.11-	PEY5	1,1	ILKAR7L11	94124		
CX5 2.0	KEK9, KEN9	2.0	113	4	11.11-02.17	PEY4, PEY5	1,1	ILKAR7L11	94124		
CX-5 2.0	KE	2.0	114	4	11.11-	PEY5	1,1	ILKAR7L11	94124		
CX5 2.0	KEC9, KEF9	2.0	114	4	11.11-12.17	PEY4, PEY5	1,1	ILKAR7L11	94124		
CX5 2.0	KEC9	2.0	115	4	01.12-02.17	PEY7	1,1	ILKAR7L11	94124		
CX-5 2.0 Skyactiv-G 160	KE	2.0	118	4	11.11-	PEY6	1,1	ILKAR7L11	94124		
CX5 2.0	KE89, KEK9, KEN9	2.0	118	4	11.11-02.17	PEY6, PEY7	1,1	ILKAR7L11	94124		
CX-5 2.0 Skyactiv-G 165	KE	2.0	121	4	11.11-	PEY6	1,1	ILKAR7L11	94124		
CX5 2.0	KE19, KEC9, KEF9	2.0	121	4	11.11-02.17	PEY6, PEY7	1,1	ILKAR7L11	94124		
CX-7											
CX7 2.3 DiSi	ER8	2.3	175	4	06.06-12.14	L3K7, L3Y7	0,8	ILTR6A-8G	3787		
CX7 2.3 DiSi	ER8	2.3	175	4	06.06-12.14	L3K7, L3Y7	0,7	SILTR6A7G	95369		
CX7 2.3 DiSi	ER1	2.3	177	4	06.06-06.09	L3K7	0,8	ILTR6A-8G	3787		
CX7 2.3 DiSi	ER8	2.3	182	4	01.07-12.12	L3Y6	0,7	SILTR6A7G	95369		
CX-7 2.3 MZR DISI Turbo (ER8)	ER	2.3	190	4	10.07-05.09	L3K4, L3-VDT	0,8	ILTR6A-8G	3787		
CX-7 2.3 MZR DISI Turbo (ER8)	ER	2.3	190	4	06.09-08.09	L3K4, L3-VDT	0,7	SILTR6A7G	95369		
CX7 2.3 DiSi	ER8	2.3	191	4	01.07-05.09	L3Y6, L3Y7, L3ZA	0,8	ILTR6A-8G	3787		
CX-7 2.3 MZR DISI Turbo (ER9)	ER	2.3	191	4	09.09-03.13	L3ZA	0,7	SILTR6A7G	95369		
DEMIO											
Demio DW (VIN 100.001→)		1.4	46	4	.98- .03	B3 SOHC	1,1	BKR6E-11	2756	14	LPG 1
Demio DW (VIN 300001→)		1.4	46	4	.00- .03	B3 SOHC	1,1	BKR5E-11	6953	33	LPG 1
Demio DW (VIN 100.001→)		1.4	53	4	.98- .03	B3 (High Power)	1,1	BKR6E-11	2756	14	LPG 1
Demio DW (VIN 300001→)		1.5	55	4	05.00- .03	B5 SOHC	1,1	BKR6E-11	2756	14	LPG 1
E 2000											
E 2000 SR (VIN→600000)		2.0	63	4	.84- .95	FE	0,8	BPR6ES	7822	2	LPG 2
E 2000 SR (VIN 700001→)		2.0	70	4	.95-	FE	1,1	BKR6E-11	2756	14	LPG 1
E 2000 SR (VIN X100001→)		2.0	70	4	.99-	FE	1,1	BKR5E-11	6953	33	LPG 1
EUNOS											
Eunos 500 1.6	CA12	1.6	79	4	04.94-10.99	B6EW, B6EX	1,1	BKR6E-11	2756	14	LPG 1
MPV											
MPV LW (VIN Y100001→)		2.0	90	4	06.99-04.02	FS DOHC	1,1	ZFR5F-11	2262	40	LPG6
MPV LW (VIN 200001→)		2.3	104	4	05.02-	MZR-L3 DOHC	1,3	ITR6F13	4477		LPG 5
MPV		2.5		6	.02-	AJ	1,0	TR5IX	7397		LPG 5
MPV		2.5		6	.06-	L3-VDT	0,8	ILTR6A-8G	3787		
MPV LV (VIN 100001→)		3.0	109	6	05.96-	JE 12V	1,1	BKR6E-11	2756	14	LPG 1
MPV LV 52 (VIN 631983→)		3.0	113	6	09.94-	JEE	1,1	ZFR6F-11	4291		LPG 6
MPV 2											
MPV 2.0	LW19	2.0	88	4	11.00-02.02	FS1R	1,1	ZFR6F-11	4291		LPG 6





e kW C
Y
I



Stock-N°

VLINE

LPG/CNG

MAZDA

MPV 2

MPV 2.0	LW19	2.0	90	4	06.99-10.00	FS1R	1,1	ZFR6F-11	4291		LPG 6
MPV 2.3	LW19	2.3	104	4	03.02-01.06	L336, L3E9	1,3	TR5AI-13	90813		LPG 5

MX-3

MX-3 EC		1.6	65	4	08.91-	B6 SOHC Cat.	1,1	BKR5E-11	6953	33	LPG 1
MX-3 EC (VIN 208015→)		1.6	79	4	.94-	B6 DOHC	1,1	BKR6E-11	2756	14	LPG 1
MX-3 EC (VIN 208015→)		1.8	95	6	.95-	K8 DOHC	1,1	BKR5E-11	6953	33	LPG 1
MX-3 EC		1.8	98	6	08.91-	K8 DOHC Cat.	1,1	BKR5E-11	6953	33	LPG 1

MX-5

MX-5 NA (VIN 200001→)		1.6	66	4	.95-	B6 DOHC	1,1	BKR6E-11	2756	14	LPG 1
MX-5 NB (VIN 100001→)		1.6	81	4	.98-	B6 DOHC	1,1	BKR5E-11	6953	33	LPG 1
MX-5 NA (VIN 100001→)		1.6	85	4	.90-	B6 DOHC Cat.	1,1	BKR6E-11	2756	14	LPG 1
MX-5 1.8-/MZR	NC18	1.8	93	4	11.05-12.14	L831	1,3	BPR5EFS-13	2359		
MX-5		1.8	93	4	.06-		1,3	TR5AI-13	90813		LPG 5
MX-5 NA (VIN 100000→)		1.9	96	4	.94-	BP DOHC Cat.	1,1	BKR6E-11	2756	14	LPG 1
MX-5 NB Automatic (VIN 300001→)		1.9	102	4	.01-	BP DOHC	1,1	BKR5E-11	6953	33	LPG 1
MX-5 NB (VIN 100001→)		1.9	103	4	.98-	BP DOHC	1,1	BKR5E-11	6953	33	LPG 1
MX-5 NB (Anniversary) (VIN 121912→)		1.9	103	4	.00-	BP DOHC	1,1	BKR5E-11	6953	33	LPG 1
MX-5 NB (VIN 200001→)		1.9	107	4	.01-	BP DOHC	1,1	BKR5E-11	6953	33	LPG 1
MX-5		2.0	118	4	01.06-	LF-VE	1,3	ILTR6A-13G	3789		

MX-6

MX-6 GE (VIN 100001→)		2.0	85	4	.92-	FS DOHC Cat.	1,1	BKR6E-11	2756	14	LPG 1
MX-6 GE (VIN 400001→)		2.0	85	4	09.94-	FS DOHC	1,1	BKR5E-11	6953	33	LPG 1
MX-6		2.2		4	.92-	F2	1,1	ZFR6F-11	4291		LPG 6
MX-6 GE (VIN 400001→)		2.5	120	6	09.94-	KL DOHC V6	1,1	ZFR5F-11	2262	40	LPG6
MX-6 GE (VIN 100001→)		2.5	121	6	.92-	KL DOHC V6 Cat.	1,1	ZFR5F-11	2262	40	LPG6

PREMACY

Premacy 1.8	CP19	1.8	74	4	07.99-08.00	FP87, FP88, FPE1	1,1	BKR5E-11	6953	33	LPG 1
Premacy 1.8	CP19	1.8	74	4	07.99-08.00	FP87, FP88, FPE1	1,1	BKR6E-11	2756	14	LPG 1
Premacy 1.8	CP19	1.8	74	4	09.00-06.05	FP87, FP88, FPE1	1,1	ZFR6F-11	4291		LPG 6
Premacy 1.8	CP19	1.8	84	4	07.99-03.05	FP88, FPD9	1,1	ZFR6F-11	4291		LPG 6
Premacy (CP) (VIN 151177→)		1.9	74	4	06.99-	FP DOHC	1,1	ZFR5F-11	2262	40	LPG6
Premacy (CP) (VIN 151177→)		1.9	85	4	06.99-	FP DOHC with VICS	1,1	ZFR5F-11	2262	40	LPG6
Premacy	CP19	2.0	96	4	08.01-06.05	FS7E, FS7G	1,1	ZFR6F-11	4291		LPG 6
Premacy 2.0	CP19	2.0	96	4	08.01-06.05	FS7E, FS7G	1,1	ZFR5F-11	2262	40	LPG6
Premacy	CR19	2.0	107	4	02.05-05.10	LFD7, LFF7	1,1	ZFR6F-11	4291		LPG 6

RX-7 TURBO

RX-7 Turbo FC (VIN 200001→)			147		.90-	RE 13 B	1,4	BUR9EQ	5483		
-----------------------------	--	--	-----	--	------	---------	-----	--------	------	--	--

RX-8

RX-8		2.6	141		09.03-12.10	13B-MSP 2 + 2spark-plug	1,1 + 1,2	RE8C-L + RE9B-T	5745 + 6701		
------	--	-----	-----	--	-------------	-------------------------	--------------	--------------------	----------------	--	--

RX-8 SPORT

RX-8 Sport		2.6	170		09.03-12.10	13B-MSP(high power)2 + 2sparkplug	1,1 + 1,2	RE8C-L + RE9B-T	5745 + 6701		
------------	--	-----	-----	--	-------------	-----------------------------------	--------------	--------------------	----------------	--	--

TRIBUTE

Tribute EP (VIN M00001→)		2.0	91	4	04.00-	Zetec 16V	1,3	PTR5A-13	2467	25	LPG 4
Tribute EP2 (VIN M00001→)		2.0	91	4	04.00-	Zetec 16V	1,3	PTR5A-13	2467	25	LPG 4





l kW C
Y
I



Stock-N°

VLINE

LPG/CNG

MAZDA

TRIBUTE

Tribute	2.0		4	.03-	Ford	1,3	PTR5A-13	2467	25	LPG 4
Tribute	2.3	110	4	.03-	MZR-L3 DOHC	1,3	ITR6F13	4477		LPG 5
Tribute V6 EP (VIN M00001→)	3.0	145	6	04.00-	Duratec 24V	1,0	TR5IX	7397		LPG 5
Tribute V6 EP2 (VIN M00001→)	3.0	145	6	04.00-	Duratec 24V	1,0	TR5IX	7397		LPG 5

XEDOS 6

Xedos 6 1.6	CA12	1.6	79	4	04.94-10.99	B6EW	1,1	BKR6E-11	2756	14	LPG 1
Xedos 6 CA (VIN 210758→)		1.6	79	4	09.94-	B6 DOHC	1,1	BKR5E-11	6953	33	LPG 1
Xedos 6 1.6	CA12	1.6	83	4	01.92-03.94	B69N	1,1	BKR6E-11	2756	14	LPG 1
Xedos 6 2.0	CA12	2.0	103	6	06.94-10.99	KF1	1,1	BKR7E-11	1283		
Xedos 6 CA (VIN 210758→)		2.0	103	6	09.94-	KF DOHC V6	1,1	BKR6E-11	2756	14	LPG 1
Xedos 6 2.0	CA12	2.0	106	6	01.92-05.94	KF27	1,1	BKR5E-11	6953	33	LPG 1
Xedos 6 2.0	CA12	2.0	106	6	01.92-05.94	KF27	1,1	BKR7E-11	1283		
Xedos 6 CA (VIN 100001→)		2.0	106	4	06.92-		1,1	BKR6E-11	2756	14	LPG 1

XEDOS 9

Xedos 9 2.0	TA12, TA2	2.0	105	6	09.93-08.00	KF42	1,1	BKR5E-11	6953	33	LPG 1
Xedos 9 2.0	TA12, TA2	2.0	105	6	09.93-08.00	KF42	1,1	BKR7E-11	1283		
Xedos 9 TA (VIN 200001→)		2.0	105	6	10.93-	KF V6 DOHC	1,1	BKR6E-11	2756	14	LPG 1
Xedos 9 TA (VIN 200001→; Miller Engine)		2.3	155	6	02.95-	KJ V6 DOHC	0,8	PZFR5F	3741		LPG 6
Xedos 9 2.3 Supercharged	TA12	2.3	155	6	07.96-08.00	KJ15, KJ17	0,8	PZFR6F	7550		LPG 6
Xedos 9 2.5	TA12	2.5	120	6	09.00-09.02	KLR4	1,1	ZFR5F-11	2262	40	LPG6
Xedos 9 2.5	TA12	2.5	120	6	09.00-09.02	KLR4	1,1	ZFR6F-11	4291		LPG 6
Xedos 9 TA V6		2.5	120	6	.01-	KJD	1,1	BKR5E-11	6953	33	LPG 1
Xedos 9 2.5 -/4WS	TA12	2.5	123	6	07.93-07.00	KL68, KLL2, KLR4	1,1	ZFR6F-11	4291		LPG 6
Xedos 9 TA (VIN 200001→)		2.5	128	6	10.93-	KLZE V6	1,1	ZFR5F-11	2262	40	LPG6

MERCEDES

190 (W201)

190 E 1.8	201	1.8	80	4	05.90-05.93	M 102.910	0,8	BP6EFS	3812	5	LPG 5
190 E	201	2.0	87	4	09.85-08.93	M 102.962	0,8	BP6EFS	3812	5	LPG 5
190 E	201	2.3	97	4	09.86-05.93	M 102.985	0,8	BP6EFS	3812	5	LPG 5
190 E 16V	201	2.5	143	4	09.88-05.93	M 102.990	0,8	BP6EFS	3812	5	LPG 5
190 E 16V Evo.2	201	2.5	173	4	05.90-05.93	M 102.992	0,8	BP6EFS	3812	5	LPG 5
190 E	201	2.6	118	6	09.86-05.93	M 103.942	0,8	BP6EFS	3812	5	LPG 5

200 (W124)

200 E	124	2.0	100	4	10.92-06.93	M 111.940	0,7	BCP6ES	4930	17	LPG 3
-------	-----	-----	-----	---	-------------	-----------	-----	--------	------	----	-------

220 (W124)

220 E	124	2.2	110	4	10.92-06.93	M 111.960	0,7	BCP6ES	4930	17	LPG 3
-------	-----	-----	-----	---	-------------	-----------	-----	--------	------	----	-------

280 (W124)

280 E	124	2.8	142	6	-06.95	M 104.942	0,7	BCP6ES	4930	17	LPG 3
-------	-----	-----	-----	---	--------	-----------	-----	--------	------	----	-------

300 (R129)

300 3.0 SL	129	3.0	140	6	09.89-05.93	M 103.984	0,6	BP5EFS	3712		
------------	-----	-----	-----	---	-------------	-----------	-----	--------	------	--	--

300 (W124)

300 E 4-Matic	124	3.0	132	6	09.86-06.93	M 103.985	0,8	BP6EFS	3812	5	LPG 5
300 E-24V	124	3.0	162	6	09.89-06.93	M 104.980	0,7	BCP6ES	4930	17	LPG 3

300 (W140)

300 2.8 SE24	140	2.8	145	6	01.93-10.98	M 104.944	0,8	BKUR5ET	2789	29	LPG 1
--------------	-----	-----	-----	---	-------------	-----------	-----	---------	------	----	-------





l kW C
Y
I



Stock-N°

VLINE

LPG/CNG

MERCEDES

320 (W124)

320 E	124	3.2	162	6	10.92-06.93	M 104.992	0,7	BCP6ES	4930	17	LPG 3
-------	-----	-----	-----	---	-------------	-----------	-----	--------	------	----	-------

400 (W124)

400 E	124	4.2	205	8	10.92-06.93	M 119.975	0,7	BCP6ES	4930	17	LPG 3
-------	-----	-----	-----	---	-------------	-----------	-----	--------	------	----	-------

500 (W124)

500 E	124	5.0	235	8	06.91-06.93	M 119.974	0,7	BCP6ES	4930	17	LPG 3
-------	-----	-----	-----	---	-------------	-----------	-----	--------	------	----	-------

600 (R129)

600 6.0 SL	129	6.0	290	12	08.91-05.93	M 120.983	1,1	PFR5R-11	4292		LPG 1
------------	-----	-----	-----	----	-------------	-----------	-----	----------	------	--	-------

A-CLASS (168)

A 140	168	1.4	60	4	10.97-08.04	M 166.940	0,8	BKUR5ET	2789	29	LPG 1
-------	-----	-----	----	---	-------------	-----------	-----	---------	------	----	-------

A 140	168	1.6	60	4	01.01-08.04	M 166.960	0,8	BKUR5ET	2789	29	LPG 1
-------	-----	-----	----	---	-------------	-----------	-----	---------	------	----	-------

A 160	168	1.6	75	4	10.97-08.04	M 166.960	0,8	BKUR5ET	2789	29	LPG 1
-------	-----	-----	----	---	-------------	-----------	-----	---------	------	----	-------

A 190	168	1.9	92	4	03.99-08.04	M 166.990	0,8	BKUR5ET	2789	29	LPG 1
-------	-----	-----	----	---	-------------	-----------	-----	---------	------	----	-------

A 210 Evolution	168	2.0	103	4	03.02-08.04	M 166.995	0,8	BKUR5ET	2789	29	LPG 1
-----------------	-----	-----	-----	---	-------------	-----------	-----	---------	------	----	-------

A-CLASS (169)

A 150	169	1.5	70	4	09.04-	M 266.920	0,9	BKR6EZB	4293		
-------	-----	-----	----	---	--------	-----------	-----	---------	------	--	--

A 170	169	1.7	85	4	09.04-08.04	M 266.940	0,9	BKR6EZB	4293		
-------	-----	-----	----	---	-------------	-----------	-----	---------	------	--	--

A 200	169	2.0	100	4	09.04-	M 266.960	0,9	BKR6EZB	4293		
-------	-----	-----	-----	---	--------	-----------	-----	---------	------	--	--

A 200 Turbo	169	2.0	142	4	09.05-	M 266.980	1,0	IFR6D10	5344		LPG 1
-------------	-----	-----	-----	---	--------	-----------	-----	---------	------	--	-------

A-CLASS (176)

A 160 1.6	176	1.6	75	4	07.15-05.18	M 270.910	0,7	SILZKFR8D7S	95875		
-----------	-----	-----	----	---	-------------	-----------	-----	-------------	-------	--	--

A 180	176	1.6	90	4	06.12-	M 270.910	0,7	SILZKFR8D7S	95875		
-------	-----	-----	----	---	--------	-----------	-----	-------------	-------	--	--

A 200	176	1.6	115	4	06.12-	M 270.910	0,7	SILZKFR8D7S	95875		
-------	-----	-----	-----	---	--------	-----------	-----	-------------	-------	--	--

A 220 4-matic	176	2.0	135	4	05.14-	M 270.920	0,7	SILZKFR8E7S	90654		
---------------	-----	-----	-----	---	--------	-----------	-----	-------------	-------	--	--

A 250	176	2.0	155	4	06.12-	M 270.920	0,7	SILZKFR8E7S	90654		
-------	-----	-----	-----	---	--------	-----------	-----	-------------	-------	--	--

A 45 AMG	176	2.0	265	4	04.13-	M 133.980	0,7	SILZKFR8D7S	95875		
----------	-----	-----	-----	---	--------	-----------	-----	-------------	-------	--	--

A-CLASS (177)

A 160	177	1.3	80	4	06.18-	M 282.914	0,7	SILZKFR8D7G	90912		
-------	-----	-----	----	---	--------	-----------	-----	-------------	-------	--	--

A 180	177	1.3	100	4	06.18-	M 282.914	0,7	SILZKFR8D7G	90912		
-------	-----	-----	-----	---	--------	-----------	-----	-------------	-------	--	--

A 200	177	1.3	110	4	06.18-	M 282.914	0,7	SILZKFR8D7G	90912		
-------	-----	-----	-----	---	--------	-----------	-----	-------------	-------	--	--

A 200	177	1.3	120	4	03.18-	M 282.914	0,7	SILZKFR8D7G	90912		
-------	-----	-----	-----	---	--------	-----------	-----	-------------	-------	--	--

A 220	177	2.0	140	4	07.18-	M 260.920	0,7	SILZKFR8F7S	97566		
-------	-----	-----	-----	---	--------	-----------	-----	-------------	-------	--	--

A 250e Plug-in Hybrid	177	1.3	118	4	08.19-	M 282.914	0,7	SILZKFR8D7G	90912		
-----------------------	-----	-----	-----	---	--------	-----------	-----	-------------	-------	--	--

A 250	177	2.0	165	4	03.18-	M 260.920	0,7	SILZKFR8F7S	97566		
-------	-----	-----	-----	---	--------	-----------	-----	-------------	-------	--	--

A 35 AMG	177	2.0	225	4	09.18-	M 260.920	0,7	SILZKFR8F7S	97566		
----------	-----	-----	-----	---	--------	-----------	-----	-------------	-------	--	--

AMG GT (X290)

AMG GT 63	290	4.0	430	8	07.18-	M 177.980	0,7	SILZKFR8F7S	97566		
-----------	-----	-----	-----	---	--------	-----------	-----	-------------	-------	--	--

AMG GT 63 S	290	4.0	470	8	07.18-	M 177.980	0,7	SILZKFR8F7S	97566		
-------------	-----	-----	-----	---	--------	-----------	-----	-------------	-------	--	--

B-CLASS (245)

B 150	245	1.5	70	4	04.05- .11	M 266.920	0,9	BKR6EZB	4293		
-------	-----	-----	----	---	------------	-----------	-----	---------	------	--	--

B 170	245	1.7	85	4	04.05- .11	M 266.940	0,9	BKR6EZB	4293		
-------	-----	-----	----	---	------------	-----------	-----	---------	------	--	--

B 180 NGT	245	2.0	85	4	04.08-	M 266.960	0,9	BKR6EZB	4293		
-----------	-----	-----	----	---	--------	-----------	-----	---------	------	--	--

B 200	245	2.0	100	4	04.05- .11	M 266.960	0,9	BKR6EZB	4293		
-------	-----	-----	-----	---	------------	-----------	-----	---------	------	--	--

B 200 Turbo	245	2.0	142	4	04.05- .11	M 266.980	1,0	IFR6D10	5344		LPG 1
-------------	-----	-----	-----	---	------------	-----------	-----	---------	------	--	-------

B-CLASS (246)

B 160 1.6	246	1.6	75	4	07.15-12.18	M 270.910	0,7	SILZKFR8D7S	95875		
-----------	-----	-----	----	---	-------------	-----------	-----	-------------	-------	--	--





l kW C
Y I



Stock-N°

VLINE

LPG/CNG

MERCEDES

B-CLASS (246)

B 180	246	1.6	90	4	11.11-	M 270.910	0,7	SILZKFR8D7S	95875		
B 200	246	1.6	115	4	11.11-	M 270.910	0,7	SILZKFR8D7S	95875		
B 200 NGT	246	2.0	115	4	11.12-	M 270.920	0,7	SILZKFR8E7S	90654		
B 220 4-matic	246	2.0	135	4	05.13-	M 270.920	0,7	SILZKFR8E7S	90654		
B 250	246	2.0	155	4	05.12-	M 270.920	0,7	SILZKFR8E7S	90654		

B-CLASS (247)

B 160	247	1.3	80	4	04.19-	M 282.914	0,7	SILZKFR8D7G	90912		
B 180	247	1.3	100	4	12.18-	M 282.914	0,7	SILZKFR8D7G	90912		
B 200	247	1.3	110	4	01.19-	M 282.914	0,7	SILZKFR8D7G	90912		
B 200	247	1.3	120	4	12.18-	M 282.914	0,7	SILZKFR8D7G	90912		
B 220	247	2.0	140	4	01.19-	M 260.920	0,7	SILZKFR8F7S	97566		
B 250e Plug-in Hybrid	247	1.3	118	4	06.20-	M 282.914	0,7	SILZKFR8D7G	90912		
B 250	247	2.0	165	4	01.19-	M 260.920	0,7	SILZKFR8F7S	97566		

C-CLASS (202)

C 180	202	1.8	90	4	06.93-06.97	M 111.920	0,7	BCP6ES	4930	17	LPG 3
C 180	202	1.8	90	4	07.97-05.00	M 111.921	0,8	BKUR5ET	2789	29	LPG 1
C 180	202	1.8	95	4	09.00-03.01	M 111.952	1,0	IFR6D10	5344		LPG 1
C 200	202	2.0	100	4	03.94-06.97	M 111.941	0,7	BCP6ES	4930	17	LPG 3
C 200	202	2.0	100	4	07.97-05.00	M 111.945	0,8	BKUR5ET	2789	29	LPG 1
C 200	202	2.0	120	4	09.00-03.01	M 111.956	1,0	IFR6D10	5344		LPG 1
C 200 Kompressor	202	2.0	132	4	09.95-10.96	M 111.944	1,0	BKUR6ET-10	2397	24	LPG 1
C 200	205	2.0	135	4	12.13-	M 274.920	0,7	SILZKFR8E7S	90654		
C 200 Kompressor	202	2.0	141	4	11.96-05.00	M 111.944	1,0	BKUR6ET-10	2397	24	LPG 1
C 220	202	2.2	110	4	06.93-09.96	M 111.961	0,7	BCP6ES	4930	17	LPG 3
C 230	202	2.3	110	4	09.96-05.97	M 111.974	0,7	BCP6ES	4930	17	LPG 3
C 230 Kompressor	202	2.3	142	4	10.95-05.00	M 111.975	1,0	BKUR6ET-10	2397	24	LPG 1
C 240 V6 (Twin Spark)	202	2.4	125	6	04.97-05.00	M 112.910	1,1	PFR5R-11	4292		LPG 1
C 240 V6 (Twin Spark)	202	2.6	125	6	09.00-03.01	M 112.915	1,1	PFR5R-11	4292		LPG 1
C 280	202	2.8	141	6	06.93-05.97	M 104.941	0,7	BCP6ES	4930	17	LPG 3
C 280 V6 (Twin Spark)	202	2.8	145	6	06.97-05.00	M 112.920	1,1	PFR5R-11	4292		LPG 1
C 36 AMG	202	3.6	206	6	01.94-05.97	M 104.941	0,7	BKR5EKU	3964		
C 36 AMG 3.6	202	3.6	206	6	01.94-01.98	M 104.941 AMG	0,8	BCP5ES	7496		LPG 3
C 43 AMG (Twin Spark)	202	4.3	225	8	09.97-05.00	M 113.944	1,1	PFR5R-11	4292		LPG 1

C-CLASS (203)

C 160 Kompressor (Engine No->30853899)	203	1.8	90	4	05.02-11.06	M 271.921	0,8	ILFR6A	3588		
C 160 Kompressor (Engine No 30853900->)	203	1.8	90	4	12.06-	M 271.921	0,8	PLKR7B8E	94716		
C 180 Kompressor (Engine No->30853899)	203	1.8	105	4	05.02-11.06	M 271.940, M 271.946	0,8	ILFR6A	3588		
C 180 Kompressor (Engine No 30853900->)	203	1.8	105	4	12.06-	M 271.940, M 271.946	0,8	PLKR7B8E	94716		
C 180	203	2.0	95	4	05.00-05.02	M 111.951	1,0	IFR6D10	5344		LPG 1
C 200 Kompressor (Engine No->30853899)	203	1.8	105	4	02.03-11.06	M 271.942	0,8	ILFR6A	3588		
C 200 Kompressor (Engine No 30853900->)	203	1.8	105	4	12.06-	M 271.942	0,8	PLKR7B8E	94716		
C 200 Kompressor (Engine No->30853899)	203	1.8	120	4	02.03-11.06	M 271.940	0,8	ILFR6A	3588		
C 200 Kompressor (Engine No 30853900->)	203	1.8	120	4	12.06-	M 271.940	0,8	PLKR7B8E	94716		





€ kW C
Y
I



Stock-Nº

VLINE

LPG/CNG

MERCEDES

C-CLASS (203)

C 200 CGI Kompressor (Engine No->30853899)	203	1.8	125	4	02.03-11.06	M 271.942	0,8	ILFR6A	3588		
C 200 CGI Kompressor (Engine No 30853900->)	203	1.8	125	4	12.06-	M 271.942	0,8	PLKR7B8E	94716		
C 200 Kompressor (Engine No 30853900->)	203	1.8	135	4	12.06-	M 271.957	0,8	PLKR7B8E	94716		
C 200 Kompressor	203	2.0	120	4	05.00-	M 111.955	1,0	IFR6D10	5344		LPG 1
C 230 1.8 Kompressor	203	1.8	120	4	06.02-04.05	M 271.948	0,8	ILFR6A	3588		
C 230 Kompressor (Engine No->30853899)	203	1.8	141	4	02.04-11.06	M 271.948	0,8	ILFR6A	3588		
C 230 Kompressor (Engine No 30853900->)	203	1.8	141	4	12.06-	M 271.948	0,8	PLKR7B8E	94716		
C 230 Kompressor	203	2.3	145	4	03.01-05.02	M 111.981	1,0	IFR6D10	5344		LPG 1
C 230	203	2.5	150	6	12.04-	M 272.920	0,8	PLKR7A	4288		
C 240 (Twin Spark)	203	2.6	125	6	05.00-	M 112.912	1,1	PFR5R-11	4292		LPG 1
C 240 4-Matic (Twin Spark)	203	2.6	125	6	07.02-	M 112.916	1,1	PFR5R-11	4292		LPG 1
C 280	203	3.0	170	6	11.04-	M 272.940	0,8	PLKR7A	4288		
C 280 4-Matic	203	3.0	170	6	02.05-	M 272.941	0,8	PLKR7A	4288		
C 32 AMG Kompressor (Twin Spark)	203	3.2	260	6	.00-	M 112.961	1,0	IFR6D10	5344		LPG 1
C 320 (Twin Spark)	203	3.2	160	6	05.00-	M 112.946	1,1	PFR5R-11	4292		LPG 1
C 320 4-Matic (Twin Spark)	203	3.2	160	6	07.02-	M 112.953	1,1	PFR5R-11	4292		LPG 1
C 350	203	3.5	200	6	12.04-	M 272.960	0,8	PLKR7A	4288		
C 350 4-Matic	203	3.5	200	6	12.04-	M 272.970	0,8	PLKR7A	4288		
C 55 AMG (Twin Spark)	203	5.4	270	8	02.04-	M 113.988	1,0	IFR6D10	5344		LPG 1

C-CLASS (204)

C 180 Kompressor	204	1.6	115	4	01.08-	M 271.910	0,8	PLKR7A	4288		
C 180 1.6 Kompressor BlueEFFICIENCY	204	1.6	115	4	02.08-01.14	M 271.910	0,8	PLKR7B8E	94716		
C 180 1.6 Kompressor BlueEFFICIENCY/ Kompressor BlueTec	204	1.6	115	4	02.08-01.14	M 271.910	0,8	PLKR7B8E	94716		
C 180	204	1.6	115	4	07.12-	M 274.910	0,7	SILZKFR8D7S	95875		
C 180 CGI	204	1.8	115	4	01.07-	M 271.820	0,8	PLKR7B8E	94716		
C 180 Kompressor (Engine No 30853900->)	204	1.8	115	4	01.07-	M 271.952	0,8	PLKR7B8E	94716		
C 200 CGI	204	1.8	135	4	01.07-	M 271.820	0,8	PLKR7B8E	94716		
C 200 CGI Kompressor (Engine No 30853900->)	204	1.8	135	4	05.07-	M 271.950	0,8	PLKR7B8E	94716		
C 200 1.8 -/BlueEFFICIENCY/CGi BlueEFFICIENCY	204	1.8	135	4	06.11-01.14	M 271.860	0,8	PLKR7B8E	94716		
C 230 4-matic	204	2.5	150	6	01.07-	M 272.911	0,8	PLKR7A	4288		
C 230	204	2.5	150	6	08.07-	M 272.921	0,8	PLKR7A	4288		
C 250 CGI	204	1.8	150	4	07.09-	M 271.860	0,8	PLKR7B8E	94716		
C 250 2.5	204	2.5	150	6	02.08-12.12	M 272.921	0,8	PLKR7A	4288		
C 280	204	3.0	170	6	05.07-	M 272.947	0,8	PLKR7A	4288		
C 280 4-Matic	204	3.0	170	6	05.07-	M 272.948	0,8	PLKR7A	4288		
C 300 4-Matic	204	3.0	170	6	07.07-	M 272.948	0,8	PLKR7A	4288		
C 300 3.0	204	3.0	170	6	02.08-01.14	M 272.947	0,8	PLKR7A	4288		
C 300	204	3.0	170	6	07.09-	M 272.947	0,8	PLKR7A	4288		
C 350	204	3.5	200	6	05.07-	M 272.961	0,8	PLKR7A	4288		
C 350 4-Matic	204	3.5	200	6	05.07-	M 272.971	0,8	PLKR7A	4288		
C 350 CGI	204	3.5	215	6	09.08-	M 272.982	0,7	SILZKR7A-S	7718		
C 63 AMG 6.2 Edition 507	204	6.2	373	8	05.13-01.14		1,0	ILZKAR7A10	6043		





e kW C
Y
I



Stock-N°

VLINE

LPG/CNG

MERCEDES

C-CLASS (204)

C 63 AMG 6.2 Edition 507	204	6.2	373	8	06.13-08.14		1,0	ILZKAR7A10	6043		
C 63 AMG	204	6.3	336	8	08.07-	M 156.985	1,0	ILZKAR7A10	6043		
C 63 AMG	204	6.3	358	8	01.11-	M 156.985	1,0	ILZKAR7A10	6043		
C 63 AMG Coupe Black Series	204	6.3	380	8	01.12-	M 156.985	1,0	ILZKAR7A10	6043		

C-CLASS (205)

C 160 1.6	205	1.6	95	4	04.15-	M 274.910	0,7	SILZKFR8D7S	95875		
C 180 1.6	205	1.6	110	4	10.18-	M 274.910	0,7	SILZKFR8D7S	95875		
C 180 1.6	205	1.6	110	4	11.18-	M 274.910	0,7	SILZKFR8D7S	95875		
C 180	205	1.6	115	4	03.14-	M 274.910	0,7	SILZKFR8D7S	95875		
C 180 1.6	205	1.6	115	4	06.16-	M 274.910	0,7	SILZKFR8D7S	95875		
C 200 EQ Boost Hybrid	205	1.5	135	4	04.18-	M 264.915	0,7	SILZKFR8F7S	97566		
C 250	205	2.0	155	4	03.14-	M 274.920	0,7	SILZKFR8E7S	90654		
C 300 e Hybrid	205	2.0	155	4	02.15-	M 274.920	0,7	SILZKFR8E7S	90654		
C 300	205	2.0	190	4	05.18-	M 264.920	0,7	SILZKFR8F7S	97566		
C 300 EQ Boost Hybrid	205	2.0	190	4	05.19-	M 264.920	0,7	SILZKFR8F7S	97566		
C 400 4-Matic	205	3.0	245	6	10.14-	M 276.823	0,7	SILZKFR8E7S	90654		
C 63 AMG	205	4.0	350	8	02.16-	M 177.980	0,7	SILZKFR8F7S	97566		
C 63 AMG S	205	4.0	375	8	10.16-	M 177.980	0,7	SILZKFR8F7S	97566		

C-COUPÉ (203)

CLC 160	203	1.6	95	4	02.09-	M 271.911	0,8	PLKR7B8E	94716		
CLC 180 Kompressor (Engine No→ 30853899)	203	1.8	105	4	05.08-	M 271.940, M 271.946	0,8	ILFR6A	3588		
CLC 180 Kompressor (Engine No 30853900→)	203	1.8	105	4	05.08-	M 271.940, M 271.946	0,8	PLKR7B8E	94716		
CLC 200 Kompressor (Engine No 30853900→)	203	1.8	135	4	05.08-	M 271.957	0,8	PLKR7B8E	94716		
CLC 200 1.8 Kompressor	203	1.8	135	4	05.08-06.11	M 271.957	0,8	PLKR7B8E	94716		
CLC 230	203	2.5	150	6	05.08-	M 272.920	0,8	PLKR7A	4288		
CLC 250 2.5	203	2.5	150	6	06.09-06.11	M 272.920	0,8	PLKR7A	4288		
CLC 350	203	3.5	200	6	05.08-	M 272.960	0,8	PLKR7A	4288		

CLA (117)

CLA 180	117	1.6	90	4	01.13-	M 270.910	0,7	SILZKFR8D7S	95875		
CLA 200	117	1.6	115	4	01.13-	M 270.910	0,7	SILZKFR8D7S	95875		
CLA 200 1.6	117	1.6	110	4	07.18-03.19	M 270.910	0,7	SILZKFR8D7S	95875		
CLA 45 AMG 2.0	117	2.0	280	4	07.15-03.19		0,7	SILZKFR8D7S	95875		
CLA 250	117	2.0	155	4	01.13-	M 270.920	0,7	SILZKFR8E7S	90654		
CLA 45 AMG	117	2.0	265	4	06.13-	M 133.980	0,7	SILZKFR8D7S	95875		

CLA (118)

CLA 180	118	1.3	100	4	03.19-	M 282.914	0,7	SILZKFR8D7G	90912		
CLA 200	118	1.3	110	4	03.19-	M 282.914	0,7	SILZKFR8D7G	90912		
CLA 200	118	1.3	120	4	03.19-	M 282.914	0,7	SILZKFR8D7G	90912		
CLA 220	118	2.0	140	4	03.19-	M 260.920	0,7	SILZKFR8F7S	97566		
CLA 250	118	2.0	165	4	03.19-	M 260.920	0,7	SILZKFR8F7S	97566		
CLA 35 AMG	118	2.0	225	4	04.19-	M 260.920	0,7	SILZKFR8F7S	97566		

CLK (208)

CLK 200	208	2.0	100	4	06.97- .02	M 111.945	0,8	BKUR5ET	2789	29	LPG 1
CLK 200 Kompressor	208	2.0	120	4	06.00-06.02	M 111.956	1,0	IFR6D10	5344		LPG 1





kw
C
Y
I



Stock-N°

VLINE

LPG/CNG

MERCEDES

CLK (208)

CLK 200 Kompressor	208	2.0	135	4	07.97-	.02	M 111.944	1,0	BKUR6ET-10	2397	24	LPG 1
CLK 230 Kompressor	208	2.3	142	4	06.97-	02.00	M 111.975	1,0	BKUR6ET-10	2397	24	LPG 1
CLK 230 Kompressor	208	2.3	145	4	03.00-	06.02	M 111.982	1,0	IFR6D10	5344		LPG 1
CLK 320 V6 (Twin Spark)	208	3.2	160	6	06.97-	.02	M 112.940	1,1	PFR5R-11	4292		LPG 1
CLK 430 (Twin Spark)	208	4.3	205	8	06.98-	.02	M 113.943	1,1	PFR5R-11	4292		LPG 1
CLK 55 (Twin Spark)	208	5.5	255	8	08.99-	.03	M 113.984	1,1	PFR5R-11	4292		LPG 1

CLK (209)

CLK 200 Kompressor (Engine No->30853899)	209	1.8	120	4	09.02-	11.06	M 271.940	0,8	ILFR6A	3588		
CLK 200 Kompressor (Engine No 30853900->)	209	1.8	120	4	10.06-		M 271.955	0,8	ILFR6A	3588		
CLK 200 Kompressor (Engine No 30853900->)	209	1.8	120	4	10.06-		M 271.955	0,8	PLKR7B8E	94716		
CLK 200 Kompressor (Engine No 30853900->)	209	1.8	120	4	12.06-		M 271.940	0,8	PLKR7B8E	94716		
CLK 200 CGI (Engine No->30853899)	209	1.8	125	4	02.03-	11.06	M 271.942	0,8	ILFR6A	3588		
CLK 200 1.8 Kompressor CGi	209	1.8	125	4	07.03-	03.10	M 271.942	0,8	PLKR7B8E	94716		
CLK 200 CGI (Engine No 30853900->)	209	1.8	125	4	12.06-		M 271.942	0,8	PLKR7B8E	94716		
CLK 200 1.8 Kompressor CGi (Engine 30853900->)	209	1.8	125	4	12.06-	03.10	M 271.942	0,8	PLKR7B8E	94716		
CLK 240 (Twin Spark)	209	2.6	125	6	02.03-		M 112.912	1,1	PFR5R-11	4292		LPG 1
CLK 280	209	3.0	170	6	01.05-		M 272.940	0,8	PLKR7A	4288		
CLK 320 (Twin Spark)	209	3.2	160	6	03.03-		M 112.955	1,1	PFR5R-11	4292		LPG 1
CLK 350	209	3.5	200	6	01.05-		M 272.960	0,8	PLKR7A	4288		
CLK 500 (Twin Spark)	209	5.0	225	8	06.02-		M 113.968	1,1	PFR5R-11	4292		LPG 1
CLK 500	209	5.5	286	8	.06-		M 273.967	0,8	PLKR7A	4288		
CLK 55 AMG (Twin Spark)	209	5.4	270	8	09.02-		M 113.987	1,0	IFR6D10	5344		LPG 1
CLK 63 AMG	209	6.3	354	8	04.06-		M 156.982	1,0	ILZKAR7A10	6043		
CLK 63 AMG	209	6.3	373	8	05.07-		M 156.982	1,0	ILZKAR7A10	6043		

CLS (257)

CLS 350 EQ Boost Hybrid	257	2.0	220	4	08.18-		M 264.920	0,7	SILZKFR8F7S	97566		
-------------------------	-----	-----	-----	---	--------	--	-----------	-----	-------------	-------	--	--

E-CLASS (124)

E 200	124	2.0	100	4	06.93-	06.97	M 111.942	0,7	BGP6ES	4930	17	LPG 3
E 200	124	2.0		4	07.93-	06.95	M 111.921	0,7	BGP6ES	4930	17	LPG 3
E 220	124	2.2	110	4	06.93-	06.95	M 111.960	0,7	BGP6ES	4930	17	LPG 3
E 280	124	2.8	142	6	06.93-	06.95	M 104.945	0,7	BGP6ES	4930	17	LPG 3
E 280	124	2.8	142	6	07.93-	02.97	M 104.942	0,7	BGP6ES	4930	17	LPG 3
E 300 4 MATIC	124	3.0	132	6	09.86-	06.93	M 103.985	0,8	BP6EFS	3812	5	LPG 5
E 300 24V	124	3.0	162	6	06.93-	06.97	M 104.980	0,7	BGP6ES	4930	17	LPG 3
E 320	124	3.2	162	6	06.93-	06.95	M 104.992	0,7	BGP6ES	4930	17	LPG 3
E 420	124	4.2	205	8	06.93-	06.95	M 119.975	0,7	BGP6ES	4930	17	LPG 3
E 500	124	5.0	235	8	06.93-	06.95	M 119.974	0,7	BGP6ES	4930	17	LPG 3

E-CLASS (207)

E 350 3.5	207	3.5	200	6	06.09-	12.11	M 272.961, M 272.988	0,8	PLKR7A	4288		
E 350 3.5	207	3.5	200	6	03.10-	12.11	M 272.961, M 272.988	0,8	PLKR7A	4288		

E-CLASS (210)

E 200	210	2.0	100	4	06.95-	06.97	M 111.942	0,8	BGP5ES	7496	16	LPG 3
E 200	210	2.0	100	4	07.97-	08.00	M 111.942	0,8	BKUR5ET	2789	29	LPG 1
E 200 Kompressor	210	2.0	120	4	06.00-	03.03	M 111.957	1,0	IFR6D10	5344		LPG 1





e kW C
Y
I



Stock-N°

VLINE

LPG/CNG

MERCEDES

E-CLASS (210)

E 200 Kompressor	210	2.0	137	4	09.96-03.03	M 111.947	1,0	BKUR6ET-10	2397	24	LPG 1
E 230	210	2.3	110	4	06.95-06.97	M 111.970	0,8	BCP5ES	7496	16	LPG 3
E 230 2.3	210	2.3	110	4	07.95-10.97		0,8	BKUR5ET	2789	29	LPG 1
E 230 2.3	210	2.3	110	4	06.96-10.97		0,8	BKUR5ET	2789	29	LPG 1
E 240 V6 (Twin Spark)	210	2.4	125	6	04.97-06.99	M 112.911	1,1	PFR5R-11	4292		LPG 1
E 240 (Twin Spark)	210	2.6	125	6	06.00-03.03	M 112.914	1,1	PFR5R-11	4292		LPG 1
E 280	210	2.8	142	6	01.96-06.99	M 104.945	0,8	BCP5ES	7496	16	LPG 3
E 280 V6 (Twin Spark)	210	2.8	150	6	03.97-03.03	M 112.921	1,1	PFR5R-11	4292		LPG 1
E 280 2.8	210	2.8	150	6	07.99-11.02		1,1	PFR5R-11	4292		LPG 1
E 320 V6 (Twin Spark)	210	3.2	165	6	06.99-03.03	M 112.941	1,1	PFR5R-11	4292		LPG 1
E 320	210	3.2	170	6	06.95-05.99	M 104.995	0,8	BCP5ES	7496	16	LPG 3
E 420 V8	210	4.2	205	8	07.95-10.97	M 119.985	0,9	BCP6ES	4930	17	LPG 3
E 430 V8 (Twin Spark)	210	4.3	205	8	04.97-03.03	M 113.940	1,1	PFR5R-11	4292		LPG 1
E 50	210	5.0	255	8	02.96-08.97	M 119.985	0,7	BKR5EKU	3964		
E 50 AMG (For USA)	210	5.0	235	8	02.96-05.99	M 119.980	0,7	BCP6ES	4930	17	LPG 3
E 55 AMG (Twin Spark)	210	5.5	260	8	09.97-03.03	M 113.980	1,1	PFR5R-11	4292		LPG 1

E-CLASS (211)

E 200 Kompressor (Engine No->30853899)	211	1.8	120	4	11.02-11.06	M 271.941	0,8	ILFR6A	3588		
E 200 NGT (Engine No->30853899)	211	1.8	120	4	03.04-11.06	M 271.941	0,8	ILFR6A	3588		
E 200 Kompressor (Engine No 30853900->)	211	1.8	120	4	12.06-07.09	M 271.941	0,8	PLKR7B8E	94716		
E 200 NGT (Engine No 30853900->)	211	1.8	120	4	12.06-07.09	M 271.941	0,8	PLKR7B8E	94716		
E 200 Kompressor (Engine No->30853899)	211	1.8	135	4	04.06-11.06	M 271.956	0,8	ILFR6A	3588		
E 200 Kompressor (Engine No 30853900->)	211	1.8	135	4	12.06-07.09	M 271.956	0,8	PLKR7B8E	94716		
E 230	211	2.5	150	6	09.07-07.09	M 272.922	0,8	PLKR7A	4288		
E 240 (Twin Spark)	211	2.6	130	6	03.02-07.09	M 112.913	1,1	PFR5R-11	4292		LPG 1
E 240 4-matic (Twin Spark)	211	2.6	130	6	03.03-07.09	M 112.917	1,1	PFR5R-11	4292		LPG 1
E 280	211	3.0	170	6	01.06-07.09	M 272.943	0,8	PLKR7A	4288		
E 280 4-Matic	211	3.0	170	6	01.06-07.09	M 272.944	0,8	PLKR7A	4288		
E 320 (Twin Spark)	211	3.2	165	6	03.02-07.09	M 112.949	1,1	PFR5R-11	4292		LPG 1
E 320 4-matic (Twin Spark)	211	3.2	165	6	03.03-07.09	M 112.954	1,1	PFR5R-11	4292		LPG 1
E 350	211	3.5	200	6	10.04-07.09	M 272.964	0,8	PLKR7A	4288		
E 350 4-matic	211	3.5	200	6	11.04-07.09	M 272.972	0,8	PLKR7A	4288		
E 350 CGI	211	3.5	215	6	.08-07.09	M 272.985	0,7	SILZKR7A-S	7718		
E 500 (Twin Spark)	211	5.0	225	8	03.02-07.09	M 113.967	1,1	PFR5R-11	4292		LPG 1
E 500 4-matic (Twin Spark)	211	5.0	225	8	03.03-07.09	M 113.969	1,1	PFR5R-11	4292		LPG 1
E 500	211	5.5	285	8	04.06-07.09	M 273.960	0,8	PLKR7A	4288		
E 500	211	5.5	300	8	04.06-07.09	M 273.962	0,8	PLKR7A	4288		
E 55 AMG (Twin Spark)	211	5.5	350	8	10.02-07.09	M 113.990	0,8	ILFR6A	3588		
E 63 AMG	211	6.3	378	8	05.06-07.09	M 156.983	1,0	ILZKAR7A10	6043		

E-CLASS (212)

E 180 1.6	212	1.6	115	4	08.13-12.15	M 274.910	0,7	SILZKFR8D7S	95875		
E 200 CGI	212	1.8	135	4	08.09-	M 271.820, M 271.860	0,8	PLKR7B8E	94716		
E 200	212	2.0	135	4	01.13-	M 274.920	0,7	SILZKFR8E7S	90654		
E 250 CGI	212	1.8	150	4	01.09-	M 271.860	0,8	PLKR7B8E	94716		





l kW C
Y
I



Stock-N°

VLINE

LPG/CNG

MERCEDES

E-CLASS (212)

E 250	212	2.0	155	4	01.13-	M 274.920	0,7	SILZKFR8E7S	90654		
E 300 3.0	212	3.0	170	6	01.09-12.13	M 272.952	0,8	PLKR7A	4288		
E 300 3.0	212	3.0	170	6	11.09-12.11	M 272.952	0,8	PLKR7A	4288		
E 350 4-matic	212	3.5	200	6	01.09-	M 272.977	0,8	PLKR7A	4288		
E 350 3.5	212	3.5	200	6	01.09-12.13	M 272.980	0,8	PLKR7A	4288		
E 350 3.5 CGi BlueEFFICIENCY	212	3.5	200	6	08.09-12.11	M 272.980	0,8	PLKR7A	4288		
E 350 CGi BlueEfficiency	212	3.5	215	6	03.09-	M 272.983	0,7	SILZKR7A-S	7718		
E 500	212	5.0	286	8	03.09-	M 273.971	0,8	PLKR7A	4288		
E 63 AMG	212	6.3	386	8	12.09-	M 156.985	1,0	ILZKAR7A10	6043		

E-CLASS (213)

E 200	213	2.0	145	4	10.18-	M 264.920	0,7	SILZKFR8F7S	97566		
E 350 EQ Boost Hybrid	213	2.0	220	4	08.18-	M 264.920	0,7	SILZKFR8F7S	97566		
E 63 AMG	213	4.0	420	8	01.17-	M 177.980	0,7	SILZKFR8F7S	97566		
E 63 AMG S	213	4.0	450	8	01.17-	M 177.980	0,7	SILZKFR8F7S	97566		

E-CLASS (238)

E 350 EQ Boost Hybrid	238	2.0	220	4	10.17-	M 264.920	0,7	SILZKFR8F7S	97566		
-----------------------	-----	-----	-----	---	--------	-----------	-----	-------------	-------	--	--

E-COUPÉ (207)

E 200 CGI Coupe / Cabriolet	207	1.8	135	4	01.10-	M 271.860	0,8	PLKR7B8E	94716		
E 200 Coupe / Cabriolet	207	2.0	135	4	03.13-	M 274.920	0,7	SILZKFR8E7S	90654		
E 250 CGI Coupe / Cabriolet	207	1.8	150	4	01.09-	M 271.860	0,8	PLKR7B8E	94716		
E 250 Coupe / Cabriolet	207	2.0	155	4	03.13-	M 274.920	0,7	SILZKFR8E7S	90654		
E 350 CGI Coupe / Cabriolet	207	3.5	215	6	01.09-	M 272.982	0,7	SILZKR7A-S	7718		
E 500 Coupe / Cabriolet	207	5.5	286	8	01.09-	M 273.966	0,8	PLKR7A	4288		

EVOBUS

EVOBUS					12.12-		0,5	T7016A	90853		
--------	--	--	--	--	--------	--	-----	--------	-------	--	--

G-CLASS (463)

200GE 2.0	463	2.0	80	4	01.90-07.93	M 102.965	0,8	BP6EFS	3812		LPG 5
G 200 2.0	463	2.0	80	4	09.93-	M 102.965	0,8	BP6EFS	3812	5	LPG 5
200GE 2.0	463	2.0	85	4	09.89-07.93	M 102.965	0,8	BP6EFS	3812		LPG 5
G 230	463	2.3	93	4	08.93-10.94	M 102.989	0,8	BP6EFS	3812	5	LPG 5
300GE 3.0	463	3.0	125	6	08.89-08.93	M 103.987	0,6	BP5EFS	3712		
300GE 3.0	463	3.0	125	6	09.89-09.97	M 103.987	0,6	BP5EFS	3712		
G 300 3.0	463	3.0	125	6	06.93-08.97	M 103.987	0,6	BP5EFS	3712		
G 300	463	3.0	126	6	08.93-10.94	M 103.987	0,8	BP6EFS	3812	5	LPG 5
300GE 3.0	463	3.0	128	6	06.90-08.97	M 103.987	0,6	BP5EFS	3712		
G 320	463	3.2	155	6	09.93-12.97	M 104.996	0,8	BCP5ES	7496	16	LPG 3
G 320 (Twin Spark)	463	3.2	158	6	07.97-	M 112.945	1,1	PFR5R-11	4292		LPG 1
G 36 AMG	463	3.2	155	6	01.95-	M 104.996	0,8	BCP5ES	7496	16	LPG 3
G 36 AMG 3.6	463	3.6	200	6	01.95-07.98	M 104.996 AMG	0,8	BCP5ES	7496		LPG 3
G 500	463	4.0	310	8	01.18-	M 176.980	0,7	SILZKFR8F7S	97566		
G 500	463	5.0	195	8	08.93-10.94	M 117.965	0,7	BP6ES	7811	4	LPG 2
G 500 (Twin Spark)	463	5.0	218	8	.00-	M 113.962	1,1	PFR5R-11	4292		LPG 1
G 500 5.5	463	5.5	285	8	05.08-	M 273.963	0,8	PLKR7A	4288		
G 55 AMG (Twin Spark)	463	5.0	218	8	04.99-	M 113.962	1,1	PFR5R-11	4292		LPG 1
G 55 AMG (Twin Spark)	463	5.5	260	8	04.99-	M 113.982	1,1	PFR5R-11	4292		LPG 1





l kW C
Y
I



Stock-N°

VLINE

LPG/CNG

MERCEDES

G-CLASS (463)

G 55 AMG (Twin Spark)	463	5.5	350	8	06.04-	M 113.993	0,8	ILFR6A	3588		
G 63 AMG (Twin Spark)	463	4.0	430	8	03.18-	M 177.980	0,7	SILZKFR8F7S	97566		
G 65 AMG 6.0	463	6.0	450	12	04.12-	M 279.982	0,8	IFR6Q-G	5648		
G 65 AMG 6.0	463	6.0	463	12	06.15-	M 279.982	0,8	IFR6Q-G	5648		

GL (X164)

GL 450	X164	4.6	250	8	01.06-	M 273.923	0,8	PLKR7A	4288		
GL 500	X164	5.5	286	8	01.06-	M 273.963	0,8	PLKR7A	4288		

GLA (146)

GLA 200 1.6	146	1.6	110	4	07.18-	M 270.910	0,7	SILZKFR8D7S	95875		
GLA 45 AMG 2.0	146	2.0	280	4	07.15-		0,7	SILZKFR8D7S	95875		

GLA (247)

GLA 200	247	1.3	120	4	02.20-	M 282.914	0,7	SILZKFR8D7G	90912		
---------	-----	-----	-----	---	--------	-----------	-----	-------------	-------	--	--

GLB (247)

GLB 180	247	1.3	100	4	04.20-	M 282.914	0,7	SILZKFR8D7G	90912		
GLB 200	247	1.3	120	4	08.19-	M 282.914	0,7	SILZKFR8D7G	90912		

GLC (253)

GLC 200 EQ Boost Hybrid	253	2.0	145	4	04.19-	M 264.920	0,7	SILZKFR8F7S	97566		
GLC 300 EQ Boost Hybrid	253	2.0	190	4	04.19-	M 264.920	0,7	SILZKFR8F7S	97566		

GLK (X204)

GLK 200	X204	2.0	135	4	08.13-	M 274.920	0,7	SILZKFR8E7S	90654		
GLK 250	X204	2.0	155	4	04.13-	M 274.920	0,7	SILZKFR8E7S	90654		
GLK 280	X204	3.0	170	6	06.08-06.09	M 272.948	0,8	PLKR7A	4288		
GLK 300	X204	3.0	170	6	07.09-	M 272.948	0,8	PLKR7A	4288		
GLK 350 3.5	X204	3.5	200	6	06.08-	M 272.961	0,8	PLKR7A	4288		
GLK 350 3.5	X204	3.5	200	6	.08-	M 272.971	0,8	PLKR7A	4288		
GLK 350 3.5	X204	3.5	200	6	04.09-06.15	M 272.991	0,8	PLKR7A	4288		

M-CLASS (163)

ML 320 (Twin Spark)	163	3.2	160	6	02.98-08.02	M 112.942	1,1	PFR5R-11	4292		LPG 1
ML 350 (Twin Spark)	163	3.7	173	6	08.00-06.05	M 112.970	1,1	PFR5R-11	4292		LPG 1
ML 430 (Twin Spark)	163	4.3	200	8	11.98-06.05	M 113.942	1,1	PFR5R-11	4292		LPG 1
ML 500 (Twin Spark)	163	5.0	215	8	09.00-06.04	M 113.965	1,1	PFR5R-11	4292		LPG 1
ML 55 AMG (Twin Spark)	163	5.5	255	8	11.99-06.05	M 113.981	1,1	PFR5R-11	4292		LPG 1

M-CLASS (164)

ML300 3.0	164	3.0	170	6	08.08-12.11	M 272.945	0,8	PLKR7A	4288		
ML 350	164	3.5	200	6	07.05-	M 272.967	0,8	PLKR7A	4288		
ML 500 (Twin Spark)	164	5.0	225	8	12.04-	M 113.964	1,1	PFR5R-11	4292		LPG 1
ML 500	164	5.5	286	8	12.07-	M 273.963	0,8	PLKR7A	4288		
ML 63 AMG	164	6.3	375	8	01.06-	M 156.980	1,0	ILZKAR7A10	6043		

R-CLASS (251)

R 280	251	3.0	170	6	02.06-	M 272.945	0,8	PLKR7A	4288		
R 280 3.0	251	3.0	170	6	05.07-12.11	M 272.945	0,8	PLKR7A	4288		
R 300 (251)	251	3.0	170	6	07.09-	M 272.945	0,8	PLKR7A	4288		
R 300 3.0	251	3.0	170	6	07.09-12.11	M 272.945	0,8	PLKR7A	4288		
R 350	251	3.5	200	6	02.06-	M 272.967	0,8	PLKR7A	4288		
R 500 (Twin Spark)	251	5.0	225	8	02.06-	M 113.971	1,1	PFR5R-11	4292		LPG 1





kw
C
Y
I



Stock-N°

VLINE

LPG/CNG

MERCEDES

R-CLASS (251)

R 500	251	5.5	286	8	01.07-	M 273.963	0,8	PLKR7A	4288		
R 63 AMG	251	6.3	375	8	11.05-	M 156.980	1,0	ILZKAR7A10	6043		

S-CLASS (140)

CL 420	140	4.2	205	8	06.96-06.97	M 119.981	0,7	BCP6ES	4930	17	LPG 3
CL 420	140	4.2	205	8	07.97-10.98	M 119.981	1,1	PFR5R-11	4292		LPG 1
CL 500	140	5.0	235	8	09.96-06.97	M 119.980	1,1	PFR5R-11	4292		LPG 1
CL 500	140	5.0	235	8	07.97-10.98	M 119.980	1,1	PFR5R-11	4292		LPG 1
CL 600	140	6.0	290	12	06.96-05.97	M 120.982	0,7	BCP6ES	4930	17	LPG 3
CL 600	140	6.0	290	12	06.97-10.98	M 120.982	1,1	PFR5R-11	4292		LPG 1
S 280 2.8	140	2.8	142	6	06.93-01.99		0,8	BKUR5ET	2789	29	LPG 1
S 280	140	2.8	142	6	07.93-06.97	M 104.944	0,7	BCP6ES	4930	17	LPG 3
S 320 3.2	140	3.2	170	6	06.93-10.98		0,8	BKUR5ET	2789	29	LPG 1
S 320	140	3.2	170	6	07.93-06.97	M 104.994	0,7	BCP6ES	4930	17	LPG 3
S 420	140	4.2	205	8	06.93-06.97	M 119.981	0,7	BCP6ES	4930	17	LPG 3
S 420	140	4.2	205	8	07.93-06.97	M 119.971	0,7	BCP6ES	4930	17	LPG 3
S 500 5.0	140	5.0	235	8	01.93-12.97		1,1	PFR5R-11	4292		LPG 1
S 500	140	5.0	235	8	07.93-06.97	M 119.970	0,7	BCP6ES	4930	17	LPG 3
S 600 6.0	140	6.0	290	12	09.91-10.98		1,1	PFR5R-11	4292		LPG 1
S 600 6.0 SEC	140	6.0	290	12	09.92-02.99		1,1	PFR5R-11	4292		LPG 1
S 600	140	6.0	290	12	06.93-06.97	M 120.982	0,7	BCP6ES	4930	17	LPG 3
S 600	140	6.0	290	12	07.93-06.97	M 120.980	0,7	BCP6ES	4930	17	LPG 3

S-CLASS (215)

CL 500 (Twin Spark)	215	5.0	225	8	09.00-03.06	M 113.960	1,1	PFR5R-11	4292		LPG 1
CL 600 (Twin Spark)	215	6.0	270	12	03.99-03.06	M 137.970	0,8	IFR6Q-G	5648		
CL 600 (Twin Spark)	215	6.0	368	12	.02-03.06	M 275.950	0,8	IFR6Q-G	5648		

S-CLASS (216)

CL 500	215	5.5	286	8	10.06-	M 273.961	0,8	PLKR7A	4288		
CL 500 4matic	216	5.5	286	8	02.08-	M 273.968	0,8	PLKR7A	4288		
CL 600 (Twin Spark)	216	6.0	381	12	09.06-	M 275.953	0,8	IFR6Q-G	5648		

S-CLASS (217)

S 560	217	4.0	345	8	10.17-	M 176.980	0,7	SILZKFR8F7S	97566		
S 63 AMG	217	4.0	450	8	10.17-	M 177.980	0,7	SILZKFR8F7S	97566		
S 65 AMG 6.0	217	6.0	463	12	07.14-05.19	M 279.980	0,8	IFR6Q-G	5648		
S 65 AMG 6.0	217	6.0	463	12	04.16-05.19	M 279.980	0,8	IFR6Q-G	5648		
S 650 Maybach 6.0	217	6.0	463	12	08.17-	M 279.980	0,8	IFR6Q-G	5648		

S-CLASS (220)

S 280 (Twin Spark)	220	2.8	142	6	10.99-08.05	M 112.922	1,1	PFR5R-11	4292		LPG 1
S 320 (Twin Spark)	220	3.2	165	6	10.98-08.05	M 112.944	1,1	PFR5R-11	4292		LPG 1
S 350 (Twin Spark)	220	3.7	180	6	09.02-08.05	M 112.972	1,1	PFR5R-11	4292		LPG 1
S 350 4-matic (Twin Spark)	220	3.7	180	6	06.03-08.05	M 112.975	1,1	PFR5R-11	4292		LPG 1
S 430 (Twin Spark)	220	4.3	205	8	10.98-08.05	M 113.941	1,1	PFR5R-11	4292		LPG 1
S 430 4-matic (Twin Spark)	220	4.3	205	8	09.02-08.05	M 113.948	1,1	PFR5R-11	4292		LPG 1
S 500 5.0 -/SEL	220	5.0	220	8	10.98-12.03		1,1	PFR5R-11	4292		LPG 1
S 500 (Twin Spark)	220	5.0	225	8	10.98-08.05	M 113.960	1,1	PFR5R-11	4292		LPG 1
S 500 4-matic (Twin Spark)	220	5.0	225	8	09.02-08.05	M 113.966	1,1	PFR5R-11	4292		LPG 1





l kW C
Y
I



Stock-N°

VLINE

LPG/CNG

MERCEDES

S-CLASS (220)

S 55 (Twin Spark)	220	5.5	265	8	.99-08.05	M 113.980	1,1	PFR5R-11	4292		LPG 1
S 55 AMG (Twin Spark)	220	5.5	265	8	04.99-08.05	M 113.986	1,1	PFR5R-11	4292		LPG 1
S 55 AMG Kompressor (Twin Spark)	220	5.5	368	8	.02-08.05	M 113.991	0,8	ILFR6A	3588		
S 600 (Twin Spark)	220	6.0	270	12	01.00-08.05	M 137.970	0,8	IFR6Q-G	5648		
S 600 (Twin Spark)	220	6.0	368	12	.01-08.05	M 275.950	0,8	IFR6Q-G	5648		
S 65 AMG (Twin Spark)	220	6.0	450	12	.03-08.05	M 275.980	0,8	IFR6Q-G	5648		

S-CLASS (221)

S 280	221	3.0	170	6	.05-	M 272.946	0,8	PLKR7A	4288		
S 280 3.0	221	3.0	170	6	08.06-07.13	M 272.946	0,8	PLKR7A	4288		
S 300 3.0 -/Blue Direct	221	3.0	170	6	01.06-07.13	M 272.946	0,8	PLKR7A	4288		
S 350	221	3.5	200	6	10.05-	M 272.965	0,8	PLKR7A	4288		
S 350 4Matic	221	3.5	200	6	06.07-	M 272.965	0,8	PLKR7A	4288		
S 400 3.5 Blue Hybrid	221	3.5	205	6	11.08-12.13	M 272.974	0,8	PLKR7A	4288		
S 400 BlueHybrid	221	3.5	205	6	01.09-	M 272.974	0,8	PLKR7A	4288		
S 450	221	4.6	250	8	07.05-	M 273.922	0,8	PLKR7A	4288		
S 450 4-Matic	221	4.6	250	8	12.05-	M 273.924	0,8	PLKR7A	4288		
S 500	221	5.5	285	8	07.05-	M 273.961	0,8	PLKR7A	4288		
S 500 4-Matic	221	5.5	285	8	10.05-	M 273.968	0,8	PLKR7A	4288		
S 600 (Twin Spark)	221	6.0	380	12	03.06-	M 275.953	0,8	IFR6Q-G	5648		
S 63 AMG	221	6.3	386	8	10.06-	M 156.984	1,0	ILZKAR7A10	6043		
S 65 AMG (Twin Spark)	221	6.0	450	12	12.05-	M 275.982	0,8	IFR6Q-G	5648		

S-CLASS (222)

S 560	222	4.0	345	8	05.17-	M 176.980	0,7	SILZKFR8F7S	97566		
S 560 Maybach	222	4.0	345	8	07.17-	M 176.980	0,7	SILZKFR8F7S	97566		
S 600 6.0	222	6.0	390	12	02.14-	M 277.980	0,8	IFR6Q-G	5648		
S 600 Maybach 6.0	222	6.0	390	12	01.15-11.18	M 277.980	0,8	IFR6Q-G	5648		
S 63 AMG	222	4.0	450	8	05.17-	M 177.980	0,7	SILZKFR8F7S	97566		
S 65 AMG 6.0	222	6.0	463	12	02.14-	M 279.980	0,8	IFR6Q-G	5648		
S 650 Maybach 6.0	222	6.0	463	12	07.17-	M 279.980	0,8	IFR6Q-G	5648		

S-CLASS COUPÉ (215)

CL 55 AMG (Twin Spark)	215	5.5	265	8	10.99-03.06	M 113.986	1,1	PFR5R-11	4292		LPG 1
CL 55 AMG Kompressor (Twin Spark)	215	5.5	368	8	.00-03.06	M 113.991	0,8	ILFR6A	3588		
CL 65 AMG (Twin Spark)	215	6.0	450	12	09.03-03.06	M 275.980	0,8	IFR6Q-G	5648		

S-CLASS COUPÉ (216)

CL 63 AMG	216	6.3	386	8	09.06-	M 156.984	1,0	ILZKAR7A10	6043		
CL 65 AMG (Twin Spark)	216	6.0	450	12	10.06-	M 275.982	0,8	IFR6Q-G	5648		

SL (129)

SL 280	129	2.8	141	6	07.93-06.97	M 104.943	0,7	BCP6ES	4930	17	LPG 3
SL 280	129	2.8	142	6	07.97-05.98	M 104.943	0,8	BKUR5ET	2789	29	LPG 1
SL 280 (Twin Spark)	129	2.8	150	6	06.98-	M 112.923	1,1	PFR5R-11	4292		LPG 1
SL 320 (Twin Spark)	129	3.2	165	6	06.98-	M 112.943	1,1	PFR5R-11	4292		LPG 1
SL 320	129	3.2	170	6	07.93-06.97	M 104.991	0,7	BCP6ES	4930	17	LPG 3
SL 320	129	3.2	170	6	07.97-05.98	M 104.991	0,8	BKUR5ET	2789	29	LPG 1
SL 500 (Twin Spark)	129	5.0	225	8	.98-	M 113.961	1,1	PFR5R-11	4292		LPG 1
SL 500 5.0	129	5.0	235	8	09.92-12.03		1,1	PFR5R-11	4292		LPG 1





kw C
Y
I



Stock-Nº

VLINE

LPG/CNG

MERCEDES

SL (129)

SL 500	129	5.0	235	8	07.93-06.97	M 119.972, M 119.982	0,7	BCP6ES	4930	17	LPG 3
SL 60	129	6.0	280	12	.95-	M 119.E60	0,7	BKR5EKU	3964		
SL 60 AMG 6.0	129	6.0	280	8	06.96-07.01	M 119.972 AMG	0,7	BCP6ES	4930		LPG 3
SL 60 AMG	129	6.0	280	12	.95-	M 119.E60	0,7	BKR5EKU	3964		
SL 600 6.0	129	6.0	290	12	07.92-10.01		1,1	PFR5R-11	4292		LPG 1
SL 600	129	6.0	290	12	07.93-06.97	M 120.983	0,8	BCP5ES	7496	16	LPG 3
SL 600	129	6.0	290	12	07.93-06.97	M 120.981	0,7	BCP6ES	4930	17	LPG 3
SL 600	129	6.0	290	12	.98-	M 120.983	1,1	PFR5R-11	4292		LPG 1
SL 73 AMG	129	7.3	386	12	.99-	M 120.E73	1,1	PFR5R-11	4292		LPG 1

SL (230)

SL 280	230	3.0	170	6	03.08-	M 272.949	0,8	PLKR7A	4288		
SL 300	230	3.0	170	6	04.09-	M 272.949	0,8	PLKR7A	4288		
SL 350	230	3.5	200	6	05.05-	M 272.966	0,8	PLKR7A	4288		
SL 350	230	3.5	233	6	04.08-	M 272.968	0,8	PLKR7A	4288		
SL 350 (Twin Spark)	230	3.7	180	6	03.03-	M 112.973	1,1	PFR5R-11	4292		LPG 1
SL 500 (Twin Spark)	230	5.0	225	8	10.01-	M 113.963	1,1	PFR5R-11	4292		LPG 1
SL 500	230	5.5	286	8	03.06-	M 273.965	0,8	PLKR7A	4288		
SL 65 AMG 6.0 Black Series	230	6.0	493	12	07.08-01.12	M 275.983	0,8	IFR6Q-G	5648		
SL 500K (Twin Spark)	230	5.0	225	8	10.01-	M 113.963	1,1	PFR5R-11	4292		LPG 1
SL 55 AMG (Twin Spark)	230	5.5	350	8	10.01-06.02	M 113.992	0,8	ILFR6A	3588		
SL 55 AMG (Twin Spark)	230	5.5	368	8	06.02-	M 113.992	0,8	ILFR6A	3588		
SL 55 AMG (Twin Spark)	230	5.5	380	8	03.06-	M 113.995	0,8	ILFR6A	3588		
SL 600 (Twin Spark)	230	5.5	368	12	04.03-	M 275.951	0,8	IFR6Q-G	5648		
SL 600 (Twin Spark)	230	5.5	381	12	03.06-	M 275.954	0,8	IFR6Q-G	5648		
SL 63 AMG	230	6.3	386	8	03.08-	M 156.981	1,0	ILZKAR7A10	6043		
SL 65 AMG (Twin Spark)	230	6.0	450	12	03.04-	M 275.981	0,8	IFR6Q-G	5648		

SL (231)

SL 65 AMG 6.0	231	6.0	463	12	01.12-	M 279.981	0,8	IFR6Q-G	5648		
SL 65 AMG	231	6.0	463	12	01.12-	M 279.981	0,8	IFR6Q-G	5648		

SLC (172)

SLC 180 1.6	172	1.6	115	4	01.16-	M 274.910	0,7	SILZKFR8D7S	95875		
-------------	-----	-----	-----	---	--------	-----------	-----	-------------	-------	--	--

SLK (170)

SLK 200	170	2.0	100	4	09.96-	M 111.946	0,8	BKUR5ET	2789	29	LPG 1
SLK 200 Kompressor	170	2.0	120	4	03.00-	M 111.958	1,0	IFR6D10	5344		LPG 1
SLK 200 Kompressor	170	2.0	141	4	09.96-02.00	M 111.943	1,0	BKUR6ET-10	2397	24	LPG 1
SLK 230 Kompressor	170	2.3	142	4	09.96-02.00	M 111.973	1,0	BKUR6ET-10	2397	24	LPG 1
SLK 230 Kompressor	170	2.3	145	4	03.00-	M 111.983	1,0	IFR6D10	5344		LPG 1
SLK 32 AMG Kompressor (Twin Spark)	170	3.2	260	6	11.00-	M 112.960	1,0	IFR6D10	5344		LPG 1
SLK 32 AMG (Twin Spark)	170	3.2	260	6	.01-	M 112.960	1,0	IFR6D10	5344		LPG 1
SLK 320 (Twin Spark)	170	3.2	160	6	03.00-	M 112.947	1,1	PFR5R-11	4292		LPG 1

SLK (171)

SLK 200 Kompressor (Engine No->30853899)	171	1.8	120	4	04.04-11.06	M 271.944	0,8	ILFR6A	3588		
SLK 200 Kompressor (Engine No 30853900->)	171	1.8	120	4	12.06-12.10	M 271.944	0,8	PLKR7B8E	94716		
SLK 200 Kompressor (Engine No 30853900->)	171	1.8	135	4	01.08-12.10	M 271.954	0,8	PLKR7B8E	94716		





l kW C
Y
I



Stock-N°

VLINE

LPG/CNG

MERCEDES

SLK (171)

SLK 280	171	3.0	170	6	01.05-	M 272.942	0,8	PLKR7A	4288		
SLK 300	171	3.0	170	6	04.09-	M 272.942	0,8	PLKR7A	4288		
SLK 350	171	3.5	200	6	06.04-	M 272.963	0,8	PLKR7A	4288		
SLK 350	171	3.5	224	6	01.08-	M 272.969	0,8	PLKR7A	4288		
SLK 55 AMG (Twin Spark)	171	5.5	265	8	04.04-02.11	M 113.989	1,0	IFR6D10	5344		LPG 1

SLK (172)

SLK 200	172	1.8	135	4	02.11-	M 271.861	0,8	PLKR7B8E	94716		
SLK 250	172	1.8	150	4	02.11-	M 271.861	0,8	PLKR7B8E	94716		

SLR (199)

SLR Mc Laren (Twin Spark)	199	5.4	460	8	04.04-01.10	M 155.980	0,8	ILFR6A	3588		
---------------------------	-----	-----	-----	---	-------------	-----------	-----	--------	------	--	--

SPRINTER 901/902

Sprinter 214 NGT 2.3	901, 902	2.3	95	4	02.95-05.06	M 111.979NGT, M 111.984 NGT	0,8	BKUR5ET	2789	29	LPG 1
Sprinter 214	901, 902	2.3	105	4	04.95-	M 111.979	0,8	BKUR5ET	2789	29	LPG 1

SPRINTER 903

Sprinter 314 NGT 2.3	903	2.3	95	4	02.95-05.06	M 111.979 NGT, M 111.984 NGT	0,8	BKUR5ET	2789	29	LPG 1
Sprinter 314 2.3	903	2.3	105	4	02.95-05.06		0,8	BKUR5ET	2789	29	LPG 1
Sprinter 314	903	2.3	105	4	04.95-	M 111.979	0,8	BKUR5ET	2789	29	LPG 1
Sprinter 314 2.3	903	2.3	105	4	04.00-05.06		0,8	BKUR5ET	2789	29	LPG 1

SPRINTER 906

Sprinter 216	906	1.8	115	4	09.08-	M 271.951	0,8	PLKR7B8E	94716		
Sprinter 224	906	3.5	190	6	06.06-	M 272.979	0,8	PLKR7A	4288		
Sprinter 316	906	1.8	115	4	09.08-	M 271.951	0,8	PLKR7B8E	94716		
Sprinter 316 NGT	906	1.8	115	4	09.08-	M 271.951	0,8	PLKR7B8E	94716		
Sprinter 316 NGT 1.8 Supercharged	906	1.8	115	4	03.09-	M 271.951 NGT	0,8	PLKR7B8E	94716		
Sprinter 316 LGT 1.8 Supercharged	906	1.8	115	4	01.11-	M 271.951	0,8	PLKR7B8E	94716		
Sprinter 324	906	3.5	190	6	06.06-	M 272.979	0,8	PLKR7A	4288		
Sprinter 424	906	3.5	190	6	06.06-	M 272.979	0,8	PLKR7A	4288		
Sprinter 516	906	1.8	115	4	09.08-	M 271.951	0,8	PLKR7B8E	94716		
Sprinter 516 NGT	906	1.8	115	4	09.08-	M 271.951	0,8	PLKR7B8E	94716		
Sprinter 516 1.8 Supercharged	906	1.8	115	4	03.09-	M 271.951	0,8	PLKR7B8E	94716		
Sprinter 524	906	3.5	190	6	06.06-	M 272.979	0,8	PLKR7A	4288		

VANEO (414)

Vaneo	414	1.6	60	4	01.02-	M 166.961	0,8	BKUR5ET	2789	29	LPG 1
Vaneo	414	1.6	75	4	01.02-	M 166.961	0,8	BKUR5ET	2789	29	LPG 1
Vaneo	414	1.9	92	4	01.02-	M 166.991	0,8	BKUR5ET	2789	29	LPG 1

V-CLASS (638)

V 200 2.0	638	2.0	95	4	08.96-07.03		0,8	BKUR5ET	2789	29	LPG 1
V 230 2.3	638	2.3	105	4	08.96-07.03		0,8	BKUR5ET	2789	29	LPG 1
V 230	638, 2	2.3	105	4	09.96-	M 111.978	0,9	BKR6EK	2288	20	LPG 1
V 280 VR6	638, 2	2.8	125	6	.98-	M 104.900 (AFS)	0,6	BKR5EKUP	2890		

VIANO (639)

Viano 3.0 (Twin Spark)	639	3.2	140	6	09.03-	M 112.951	1,1	PFR5R-11	4292		LPG 1
Viano 3.2	639	3.2	190	6	09.05-	M 272.978	0,8	PLKR7A	4288		
Viano 3.5	639	3.5	190	6	09.07-	M 272.979	0,8	PLKR7A	4288		





l kW C
Y
I



Stock-N°

VLINE

LPG/CNG

MERCEDES

VIANO (639)

Viano 3.5 (Twin Spark)	639	3.7	170	6	01.05-	M 112.976	1,1	PFR5R-11	4292		LPG 1
------------------------	-----	-----	-----	---	--------	-----------	-----	----------	------	--	-------

VITO (638)

Vito 113 2.0	638	2.0	95	4	11.95-07.03		0,8	BKUR5ET	2789	29	LPG 1
Vito 114 2.3	638	2.3	105	4	08.96-07.03		0,8	BKUR5ET	2789	29	LPG 1

VITO (639)

Vito 113	639	2.0	95	4	03.96-	M 111.948, M 111.950	1,0	BKUR5ET-10	7553		LPG 1
Vito 114	639	2.3	105	4	03.96-07.03	M 111.978	1,0	BKUR5ET-10	7553		LPG 1
Vito 126 3.5	639	3.5	190	6	09.07-	M 272.978	0,8	PLKR7A	4288		

MINI

MINI CLUBMAN COOPER

Mini Clubman Cooper	F54	1.5	100	3	07.15-	B36A15A, B38A15A	0,8	SILZKGR8B8S	94201		
Mini Clubman Cooper	R55	1.6	85	4	03.10-	N16 B16A	0,8	PLZKBR7B8G	91530		
Mini Clubman 1.6 Cooper	R55	1.6	85	4	03.10-12.15	N16B16A	0,8	PLZKBR7B8G	91530		
Mini Clubman Cooper	R55	1.6	88	4	09.07-	N12 B16A	0,8	PLZKBR7B8G	91530		
Mini Clubman Cooper	R55	1.6	90	4	03.10-	N16 B16A	0,8	PLZKBR7B8G	91530		
Mini Clubman 1.6 Cooper	R55	1.6	90	4	03.10-12.15	N16B16A	0,8	PLZKBR7B8G	91530		
Mini Clubman Cooper S	R55	1.6	120	4	10.07-02.10	N14 B16A	0,8	PLZKBR7B8G	91530		
Mini Clubman 1.6 Cooper S	R55	1.6	120	4	10.07-06.14	N14B16A	0,8	PLZKBR7B8G	91530		
Mini Clubman 1.6 Cooper S	R55	1.6	128	4	08.07-07.10	N14B16A, N14B16AB	0,8	PLZKBR7B8G	91530		
Mini Clubman Cooper S	R55	1.6	128	4	10.07-	N14 B16A	0,8	PLZKBR7B8G	91530		
Mini Clubman Cooper S	R55	1.6	135	4	03.10-	N18 B16A	0,8	PLZKBR7B8G	91530		
Mini Clubman Cooper S	R55	1.6	147	4	03.10-	N18 B16A	0,8	PLZKBR7B8G	91530		
Mini Clubman 2.0 Cooper S	F54	2.0	120	4	11.14-	B46A20A, B48A20A, B48A20F	0,8	SILZKGR8B8S	94201		
Mini Clubman 2.0 Cooper SX	F54	2.0	120	4	04.15-	B48A20A	0,8	SILZKGR8B8S	94201		
Mini Clubman Cooper S	F54	2.0	141	4	07.15-	B46A20A, B48A20A	0,8	SILZKGR8B8S	94201		
Mini Clubman 2.0 Cooper S	F54	2.0	155	4	11.14-	B46A20A, B48A20A	0,8	SILZKGR8B8S	94201		
Mini Clubman 2.0 Cooper JCW	F54	2.0	170	4	11.15-06.19	B48A20B	0,8	SILZKGR8B8S	94201		

MINI CLUBMAN JOHN COOPER WORKS

Mini Clubman John Cooper Works	R55	1.6	155	4	03.08-	N14 B16C	0,8	ILZKBR7B8G	97968		
--------------------------------	-----	-----	-----	---	--------	----------	-----	------------	-------	--	--

MINI CLUBMAN ONE

Mini Clubman One	R55	1.4	70	4	03.09-02.10	N12 B14A	0,8	PLZKBR7B8G	91530		
Mini Clubman One	R55	1.4	72	4	03.10-	N12 B14A	0,8	PLZKBR7B8G	91530		
Mini Clubman One	F54	1.5	75	3	11.15-	B38A15A	0,8	SILZKGR8B8S	94201		
Mini Clubman One	R55	1.6	72	4	03.10-	N16 B16A	0,8	PLZKBR7B8G	91530		
Mini Clubman 1.6 One	R55	1.6	72	4	03.10-12.15	N16B16A	0,8	PLZKBR7B8G	91530		

MINI CLUBVAN

Mini Clubvan 1.6 One	R55	1.6	72	4	12.12-12.15	N16B16A	0,8	PLZKBR7B8G	91530		
Mini Clubvan 1.6 Cooper	R55	1.6	90	4	12.12-12.15	N16B16A	0,8	PLZKBR7B8G	91530		

MINI COOPER

Mini Cooper	F55, F56	1.5	100	3	12.13-	B38A15A	0,8	SILZKGR8B8S	94201		
Mini Cooper	F57	1.5	100	3	11.15-	B38A15A	0,8	SILZKGR8B8S	94201		
Mini Cooper	R50	1.6	85	4	04.01-	W10 B16	1,5	BKR6EQUIP	3199	30	LPG 1
Mini Cooper 1.6	R56, R57	1.6	85	4	10.07-12.14	N16B16A	0,8	PLZKBR7B8G	91530		
Mini Cooper	R56	1.6	88	4	09.06-	N12 B16	0,8	PLZKBR7B8G	91530		





e kW C
Y
I



Stock-N°

VLINE

LPG/CNG

MINI

MINI COOPER

Mini Cooper 1.6	R57	1.6	88	4	12.08-07.10	N12B16A	0,8	PLZKBR7B8G	91530		
Mini Cooper 1.6	R56, R57	1.6	90	4	09.09-12.14	N16B16A	0,8	PLZKBR7B8G	91530		
Mini Cooper	R56	1.6	90	4	03.10-	N16 B16A	0,8	PLZKBR7B8G	91530		
Mini Cooper S	R56	1.6	120	4	03.10-	N18 B16A	0,8	PLZKBR7B8G	91530		
Mini Cooper S 16V	R53	1.6	125	4	12.01-	W11 B16	1,5	BKR6EQUP	3199	30	LPG 1
Mini Cooper S	R56	1.6	128	4	09.06-	N14 B16A	0,8	PLZKBR7B8G	91530		
Mini Cooper 1.6 S	R56	1.6	128	4	11.06-01.11	N14B16AB	0,8	PLZKBR7B8G	91530		
Mini Cooper S	R56	1.6	135	4	03.10-	N18 B16	0,8	PLZKBR7B8G	91530		
Mini Cooper 1.6 S JCW Tuning-Kit	R57	1.6	141	4	03.09-12.10	N14B16AB	0,8	PLZKBR7B8G	91530		
Mini Cooper S 16V JCW	R53	1.6	147	4	01.03-	W11 B16	1,5	BKR7EQUP	4285		
Mini Cooper 1.6 S Works	R53	1.6	149	4	11.03-06.05	W11B16A	1,5	BKR7EQUP	4285		
Mini Cooper 1.6 S Works	R52, R53	1.6	155	4	11.03-11.07	W11B16A	1,5	BKR7EQUP	4285		
Mini Cooper 1.6 S JCW GP	R53	1.6	160	4	01.06-07.07	W11B16A	1,5	BKR7EQUP	4285		
Mini Cooper S	F55, F56	2.0	120	4	09.13-	B46A20A	0,8	SILZKGR8B8S	94201		
Mini Cooper 2.0 S	F57	2.0	120	4	11.14-	B46A20A, B48A20A	0,8	SILZKGR8B8S	94201		
Mini Cooper S	F55, F56	2.0	141	4	12.13-	B46A20A, B48A20A	0,8	SILZKGR8B8S	94201		
Mini Cooper S	F57	2.0	141	4	11.15-	B48A20A	0,8	SILZKGR8B8S	94201		
Mini Cooper 2.0 S	F55, F56	2.0	155	4	10.14-	B46A20A, B48A20A	0,8	SILZKGR8B8S	94201		
Mini Cooper 2.0 S	F57	2.0	155	4	11.15-	B48A20A	0,8	SILZKGR8B8S	94201		

MINI COUNTRYMAN

Mini Countryman 1.5 One	F60	1.5	75	3	07.17-	B38A15A	0,8	SILZKGR8B8S	94201		
Mini Countryman Cooper	F60	1.5	100	3	10.16-	B36A15A, B38A15A	0,8	SILZKGR8B8S	94201		
Mini Countryman 1.5 SE Plug-in Hybrid	F60	1.5	100	3	01.17-	B38A15A	0,8	SILZKGR8B8S	94201		
Mini Countryman One	R60	1.6	72	4	06.10-	N16 B16A	0,8	PLZKBR7B8G	91530		
Mini Countryman 1.6 One	R60	1.6	72	4	06.10-	N16B16A	0,8	PLZKBR7B8G	91530		
Mini Countryman Cooper	R60	1.6	85	4	06.10-	N16 B16A	0,8	PLZKBR7B8G	91530		
Mini Countryman 1.6 Cooper	R60	1.6	85	4	06.10-	N16B16A	0,8	PLZKBR7B8G	91530		
Mini Countryman Cooper	R60	1.6	90	4	06.10-	N16 B16A	0,8	PLZKBR7B8G	91530		
Mini Countryman 1.6 Cooper	R60	1.6	90	4	06.10-	N16B16A	0,8	PLZKBR7B8G	91530		
Mini Countryman 1.6 Cooper X	R60	1.6	90	4	11.14-	N16B16A	0,8	PLZKBR7B8G	91530		
Mini Countryman Cooper S ALL4	R60	1.6	120	4	06.10-	N18 B16A	0,8	PLZKBR7B8G	91530		
Mini Countryman Cooper S	R60	1.6	135	4	06.10-	N18 B16A	0,8	PLZKBR7B8G	91530		
Mini Countryman Cooper S	R60	1.6	147	4	02.12-	N18 B16A	0,8	PLZKBR7B8G	91530		
Mini Countryman Cooper S	F60	2.0	120	4	10.16-	B46A20A, B48A20A	0,8	SILZKGR8B8S	94201		
Mini Countryman Cooper S	F60	2.0	141	4	10.16-	B46A20A, B48A20A	0,8	SILZKGR8B8S	94201		
Mini Countryman 2.0 Cooper SX JCW	F60	2.0	170	4	01.17-06.19	B48A20B	0,8	SILZKGR8B8S	94201		

MINI COUPE

Mini Coupe Cooper	R58	1.6	85	4	09.11-	N16 B16A	0,8	PLZKBR7B8G	91530		
Mini Coupe 1.6 Cooper	R58	1.6	85	4	09.11-	N16B16A	0,8	PLZKBR7B8G	91530		
Mini Coupe Cooper	R58	1.6	90	4	09.11-	N16 B16A	0,8	PLZKBR7B8G	91530		
Mini Coupe 1.6 Cooper	R58	1.6	90	4	09.11-	N16B16A	0,8	PLZKBR7B8G	91530		
Mini Coupe Cooper S	R58	1.6	120	4	09.11-	N18 B16A	0,8	PLZKBR7B8G	91530		
Mini Coupe Cooper S	R58	1.6	135	4	09.11-	N18 B16A	0,8	PLZKBR7B8G	91530		
Mini Coupe Cooper S	R58	1.6	147	4	09.11-	N18 B16A	0,8	PLZKBR7B8G	91530		
Mini Coupe John Cooper Works	R58	1.6	155	4	09.11-	N14 B16C	0,8	ILZKBR7B8G	97968		





l kW C
Y
I



Stock-N°

VLINE

LPG/CNG

MINI

MINI JOHN COOPER WORKS

Mini John Cooper Works	R56	1.6	155	4	05.08-	N14 B16	0,8	ILZKBR7B8G	97968		
Mini John Cooper Works	R56	1.6	160	4	07.07-	N14 B16	0,8	ILZKBR7B8G	97968		
Mini John Cooper Works	F56	2.0	170	4	03.15-	B48A20B	0,8	SILZKGR8B8S	94201		
Mini John Cooper Works	F57	2.0	170	4	03.16-	B48A20B	0,8	SILZKGR8B8S	94201		

MINI ONE

Mini One	F55, F56	1.2	55	3	06.14-	B38A12A	0,8	SILZKGR8B8S	94201		
Mini One	F55, F56	1.2	75	3	03.14-	B38A12A	0,8	SILZKGR8B8S	94201		
Mini One	F57	1.2	75	3	03.16-	B38A12A	0,8	SILZKGR8B8S	94201		
Mini One	R50	1.4	55	4	09.02-12.04	W10 B14	1,5	BKR6EQUIP	3199	30	LPG 1
Mini One	R56	1.4	55	4	03.09-03.10	N12 B14A	0,8	PLZKBR7B8G	91530		
Mini One 1.4 LPG	R56	1.4	55	4	03.09-03.10	N12B14A	0,8	PLZKBR7B8G	91530		
Mini One	R56	1.4	70	4	11.06-03.10	N12 B14A	0,8	PLZKBR7B8G	91530		
Mini One	R56	1.6	55	4	03.10-	N16 B16A	0,8	PLZKBR7B8G	91530		
Mini One 1.6 -/First	R56	1.6	55	4	03.10-11.13	N16B16A	0,8	PLZKBR7B8G	91530		
Mini One	R50	1.6	66	4	04.01-	W10 B16	1,5	BKR6EQUIP	3199	30	LPG 1
Mini One	R56	1.6	72	4	03.10-	N16 B16	0,8	PLZKBR7B8G	91530		
Mini One 1.6	R56, R57	1.6	72	4	03.10-12.14	N16B16A	0,8	PLZKBR7B8G	91530		

MINI PACEMAN

Mini Paceman 1.6 Cooper X	R61	1.6	85	4	07.13-09.16	N16B16A	0,8	PLZKBR7B8G	91530		
Mini Paceman Cooper	R61	1.6	90	4	04.12-	N16 B16A	0,8	PLZKBR7B8G	91530		
Mini Paceman 1.6 Cooper	R61	1.6	90	4	01.13-09.16	N16B16A	0,8	PLZKBR7B8G	91530		
Mini Paceman 1.6 Cooper X	R61	1.6	90	4	05.13-09.16	N16B16A	0,8	PLZKBR7B8G	91530		
Mini Paceman Cooper S	R61	1.6	135	4	04.12-	N18 B16A	0,8	PLZKBR7B8G	91530		
Mini Paceman John Cooper Works	R61	1.6	160	4	09.12-	N18 B16C	0,8	ILZKBR7B8G	97968		

MINI ROADSTER

Mini Roadster Cooper	R59	1.6	85	4	02.12-	N16 B16A	0,8	PLZKBR7B8G	91530		
Mini Roadster 1.6 Cooper	R59	1.6	85	4	02.12-	N16B16A	0,8	PLZKBR7B8G	91530		
Mini Roadster Cooper	R59	1.6	90	4	02.12-	N16 B16A	0,8	PLZKBR7B8G	91530		
Mini Roadster 1.6 Cooper	R59	1.6	90	4	02.12-	N16B16A	0,8	PLZKBR7B8G	91530		
Mini Roadster Cooper S	R59	1.6	120	4	02.12-	N18 B16A	0,8	PLZKBR7B8G	91530		
Mini Roadster Cooper S	R59	1.6	135	4	02.12-	N18 B16A	0,8	PLZKBR7B8G	91530		
Mini Roadster Cooper S	R59	1.6	147	4	02.12-	N18 B16A	0,8	PLZKBR7B8G	91530		
Mini Roadster John Cooper Works	R59	1.6	155	4	02.12-	N14 B16C	0,8	ILZKBR7B8G	97968		

MITSUBISHI

2000 GTX

2000 GTX		2.0		4	.94-	4G63	1,1	BKR5E-11	6953	33	LPG 1
----------	--	-----	--	---	------	------	-----	----------	------	----	-------

3000 GT

3000 GT		3.0	210	6	09.92- .00	6G72 T DOHC	1,1	PFR6J-11	2743		
3000 GT		3.0		6	.95- .00	6G72 MPI TC	1,1	PFR6J-11	2743		
3000 GT		3.0		6	.97-	6G7	1,1	PFR6J-11	2743		

AIRTREK

Airtrek		2.0	93	4	.02-	4G63 MPI	1,1	BKR6E-11	2756	14	LPG 1
Airtrek		2.0		4	06.02-	4G63	0,7	PGR6A	4984		
Airtrek		2.4		4	01.03-	4G64	1,1	BKR5E-11	6953	33	LPG 1





l kW C
Y
I



Stock-N°

VLINE

LPG/CNG

MITSUBISHI

ASX

ASX 1.6 Mivec	GA1W	1.6	85	4	05.10-	4A92	1,1	DILFR5A11	93759		
ASX 1.6	GA1W	1.6	86	4	06.10-	4A92	1,1	DILFR5A11	93759		
ASX 1.6 BiFuel	GA1W	1.6	86	4	06.10-	4A92	1,1	DILFR5A11	93759		
ASX 1.8	GA3W	1.8	102	4	02.10-	4B10	0,8	FR6EI	2687		FR6EI
ASX 2.0 Mivec	GA2W, GA9W	2.0	110	4	11.09-	4B11, 4J11	0,8	FR6EI	2687		FR6EI
ASX 2.0 Mivec	GA2W, GA9W	2.0	110	4	04.10-	4B11, 4J11	0,8	FR6EI	2687		FR6EI
ASX 2.0	GA2W	2.0	110	4	06.10-	4B11	0,8	FR6EI	2687		FR6EI

ATTRAGE

Attrage 1.2	A13A	1.2	59	3	10.13-	3A92	1,1	DILFR6A11	97362		
-------------	------	-----	----	---	--------	------	-----	-----------	-------	--	--

CARISMA

Carisma 1.3		1.3	55	4	09.00-10.04	4G13	1,1	BKR6E-11	2756	14	LPG 1
Carisma 1.3	DA6A	1.3	60	4	01.02-12.03	4G13S	1,1	BKR6E-11	2756	14	LPG 1
Carisma 1600 DAO		1.6	66	4	07.95- .99	4G92	1,1	BKR6E-11	2756	14	LPG 1
Carisma		1.6		4	.97- .99	4G92 SOHC	1,1	BKR6E-11	2756	14	LPG 1
Carisma 1.8	DA2A	1.8	85	4	07.95-06.06	4G93	0,6	IZFR6B	3116		
Carisma 1800 DAO		1.8	85	4	09.95-	4G93	1,1	BKR6E-11	2756	14	LPG 1
Carisma 1.8	DA2A	1.8	85	4	09.96-06.06	4G93	0,6	IZFR6B	3116		
Carisma GDI		1.8	92	4	09.97-	4G93 GDI	0,6	IZFR6B	3116		
Carisma Elegance GDI		1.8	92	4	.99-	4G93 GDI	0,6	IZFR6B	3116		
Carisma 1800 DAO		1.8	103	4	09.95-	4G93	1,1	BKR6E-11	2756	14	LPG 1
Carisma		1.8		4	.97- .00	4G93 SOHC	1,1	BKR6E-11	2756	14	LPG 1

CHALLENGER

Challenger 3.0	K96W	3.0	125	6	06.00-12.05	6G72 DOHC	1,1	PFR5J-11	4642		
Challenger 3.0	K96W	3.0	130	6	03.98-10.00	6G72 DOHC	1,1	PFR5J-11	4642		

CHAMP

Champ 1300		1.3		4	.94-	4G13	0,8	BP5ES	6511	8	LPG 2
Champ 1500		1.5		4	.94-	4G15	1,1	BPR5ES-11	4424		LPG 2

CHARIOT

Chariot 1.8	N31W	1.8	90	4	10.91-10.98	4G93	0,9	BKR6E	6962	28	LPG 1
Chariot 2.4	N43W	2.4	86	4	10.91-10.97	4G64S	1,1	BKR6E-11	2756	14	LPG 1
Chariot 2.4	N43W	2.4	86	4	10.91-10.97	4G64S	1,1	BPR6ES-11	4824	13	LPG 2
Chariot 2.4	N34W	2.4	88	4	10.91-10.97	4G64S	1,1	BKR6E-11	2756	14	LPG 1
Chariot 2.4	N34W	2.4	88	4	10.91-10.97	4G64S	1,1	BPR6ES-11	4824	13	LPG 2

COLT 2

Colt 1600		1.6		4	- .92		0,8	BPR6ES	7822	2	LPG 2
-----------	--	-----	--	---	-------	--	-----	--------	------	---	-------

COLT 3

Colt 1300		1.3		4	.89- .92	4G13	1,1	BPR6ES-11	4824	13	LPG 2
Colt 1500		1.5		4	.91-	4G15 Cat.	1,1	BPR6ES-11	4824	13	LPG 2
Colt 1500		1.5		4	-12.93	4G15	0,8	BPR6ES	7822	2	LPG 2

COLT 4

Colt 1.3	CA1A	1.3	55	4	12.91-08.95	4G13M	1,1	BPR5ES-11	4424		LPG 2
Colt 1300		1.3	55	4	.93- .94	4G13/MPI Cat.	1,1	BPR6ES-11	4824	13	LPG 2
Colt 1300		1.3		4	.92-	4G13/MPI	1,1	BPR5ES-11	4424		LPG 2
Colt 1300		1.3		4	.95-	4G13	1,1	BPR5ES-11	4424		LPG 2





l kW C
Y
I



Stock-N°

VLINE

LPG/CNG

MITSUBISHI

COLT 4

Colt 1500		1.5	69	4	.94-	4G15	0,8	BP5ES	6511	8	LPG 2
Colt 1.6	CA4A	1.6	66	4	02.94-04.96	4G92	1,1	BKR5E-11	6953	33	LPG 1
Colt 1600 16V		1.6	83	4	12.91-	4G92	0,8	BPR6ES	7822	2	LPG 2
Colt 1600		1.6	83	4	.94- .95	4G92 MPI	1,1	BKR6E-11	2756	14	LPG 1
Colt 1.6	CC4A	1.6	84	4	03.92-08.95	4G92	1,1	BKR6E-11	2756	14	LPG 1
Colt 1600		1.6		4	.92- .93	4G92	1,1	BKR6E-11	2756	14	LPG 1
Colt 1600		1.6		4	.95- .96	4G92 MPI MVV	1,1	BKR6E-11	2756	14	LPG 1
Colt 1800 GTI 16V		1.8	103	4	.94-	4G93 MPI	1,1	BKR6E-11	2756	14	LPG 1

COLT 5

Colt 1300		1.3	55	4	03.96-	4G13	1,1	BPR5ES-11	4424		LPG 2
Colt 1.3	CJ1A	1.3	55	4	05.96-09.00	4G13M	0,8	BP5ES	6511		LPG 2
Colt 1300		1.3	60	4	09.00-		1,1	BKR6E-11	2756	14	LPG 1
Colt 1300		1.3		4	.97-	4G13	1,1	BPR5ES-11	4424		LPG 2
Colt		1.6	66	4	03.96- .03	4G92	1,1	BKR6E-11	2756	14	LPG 1
Colt 1600		1.6	66	4	03.96-	4G92	1,1	BKR6E-11	2756	14	LPG 1
Colt 1.6	CJ4A	1.6	66	4	05.96-09.00	4G92	1,1	BKR5E-11	6953	33	LPG 1
Colt 1600		1.6		4	.97-	4G9 MVV, 4G9 (not MVV Magermix)	1,1	BKR6E-11	2756	14	LPG 1

COLT 6

Colt 1.1	Z31A, Z32A	1.1	55	3	10.04-06.10	3A91	1,1	LF6C-11	5788	48	
Colt 1.1 BiFuel	Z31A	1.1	55	3	10.04-06.12	3A91	1,1	ILZFR6C-11K	90428		
Colt 1.1	Z31A	1.1	55	3	10.04-06.10	3A91	1,1	ILZFR6C-11K	90428		
Colt 1.1 BiFuel	Z31A	1.1	55	3	10.04-06.12	3A91	1,1	LZFR5BI-11	93298		
Colt 1.1	Z31A, Z32A	1.1	55	3	07.10-06.12	3A91	1,1	LZFR5BI-11	93298		
Colt 1.3	Z33A, Z34A	1.3	70	4	06.04-06.10	4A90 16V	1,1	LF6C-11	5788	48	
Colt 1.3 Bifuel LPG	Z33A, Z34A	1.3	70	4	06.04-06.12	4A90 16V	1,1	LZFR6BI-11	95181		
Colt 1.3 BiFuel	Z33A	1.3	70	4	06.04-06.12	4A90	1,1	ILZFR6C-11K	90428		
Colt 1.3	Z33A	1.3	70	4	06.04-06.10	4A90	1,1	ILZFR6C-11K	90428		
Colt 1.3 Flex	Z35A	1.3	70	4	10.08-06.12	4A90	1,1	ILZFR6C-11K	90428		
Colt 1.3	Z33A, Z34A	1.3	70	4	07.10-06.12	4A90 16V	1,1	LZFR6BI-11	95181		
Colt Z21A		1.3		4	.09-	4A90 MIVEC DOHC	1,1	ILZFR6C-11K	90428		
Colt 1.5	Z36A	1.5	80	4	01.05-12.12	4A91	1,1	LF6C-11	5788	48	
Colt Z36A		1.5	80	4	04.05-	4A91 16V	0,8	ILZFR6C-K	6645		
Colt CZC Z36A		1.5	80	4	04.05-07.08	4A91 16V	0,8	ILZFR6C-K	6645		
Colt CZC 1.5	Z36A	1.5	80	4	03.06-07.08	4A91	1,1	LF6C-11	5788	48	
Colt CZC Z37A		1.5	110	4	03.05-07.08	4G15T DOHC	0,8	ILZFR6C-K	6645		
Colt CZT Z37A		1.5	110	4	03.05-	4G15T DOHC	0,8	ILZFR6C-K	6645		
Colt CZC 1.5	Z37A	1.5	110	4	03.06-07.08	4G15 DOHC	0,8	ILZFR6C-K	6645		

CORDIA

Cordia		1.6		4	.82-	4G32	0,9	BPR5ES	7422	6	LPG 2
--------	--	-----	--	---	------	------	-----	--------	------	---	-------

DEBONAIR

Debonair 3000				4	.91-	6G72	0,8	BP5ES	6511	8	LPG 2
---------------	--	--	--	---	------	------	-----	-------	------	---	-------

DIAMANTE

Diamante 2500 GDI	F31A, F41A	2.5			09.99-09.01	6G73	0,8	IZFR5C	7748		
Diamante 3000		3.0		6	.94-	6G72 MPI DOHC	0,8	BK6E	3536		LPG 1
Diamante 3000		3.0		6	.94-	6G72 MPI SOHC	1,1	BPR6ES-11	4824	13	LPG 2



e kW C
Y I

Stock-N°

VLINE

LPG/CNG

MITSUBISHI**DIAMANTE**

Diamante 3000 GDI	F36A, F46A	3.0		6	09.99-09.01	6G72		0,8	IZFR5C	7748		
-------------------	------------	-----	--	---	-------------	------	--	-----	--------	------	--	--

ECLIPSE

Eclipse 2000 D30		2.0	107	4	11.95-04.99	4G63		1,1	BPR6ES-11	4824	13	LPG 2
Eclipse 2000		2.0	110	4	.91-10.95	4G63 MPI DOHC		0,8	BPR7ES	2023	19	BPR8EIX
Eclipse		2.0		4	.97-	4G6		1,1	BPR6ES-11	4824	13	LPG 2
Eclipse 2400		2.4	105	4	09.98-04.99	4G64		1,1	BKR5E-11	6953	33	LPG 1
Eclipse V6 24V		3.0	147	6	07.03-	4G72 SOHC MPI		0,8	FR6EI	2687		FR6EI

ETERNA

Eterna 2000	E74A, E84A	2.0		4	05.92-10.94	6A12		0,8	PFR6J	2645		
Eterna 2500	EC5A	2.5		4	08.96-	6A13		0,8	PFR6J	2645		

EVO 10

Evolution X		2.0	217	4	04.08-09.10	4B11 FQ30		0,6	ILKR8E6	1422		
Evolution X		2.0	217	4	10.10-	4B11 FQ30		0,6	DILKR8B6	91448		

EVO 6

Evolution VI	CP9A	2.0	206	4	02.98-05.99	4G63 Turbo		0,8	PGR7A	3200		
Evolution VI Tommi Makinen Edit.	CP9A	2.0	250	4	01.99-	4G63 Turbo		0,8	IGR7A	6687		

EVO 7

Evolution VII	CT9A	2.0	206	4	.01-	4G63 Turbo		0,8	IGR7A-G	3106		
---------------	------	-----	-----	---	------	------------	--	-----	---------	------	--	--

EVO 8

Evolution VIII	CT9A	2.0	195	4	.04-	4G63 Turbo		0,8	IGR7A-G	3106		
----------------	------	-----	-----	---	------	------------	--	-----	---------	------	--	--

EVO 9

Evolution IX	CT9A	2.0	195	4	03.05-	4G63 Turbo D4(WVT) DOHC		0,6	ILFR7H	5245		
--------------	------	-----	-----	---	--------	-------------------------	--	-----	--------	------	--	--

EXPO

Expo 1800 LRV		1.8		4	.94-	4G93 MPI		1,1	BKR5E-11	6953	33	LPG 1
Expo 2400 / LRV		2.4	113	4	.94-	4G64 MPI SOHC		1,1	BKR5E-11	6953	33	LPG 1

GALANT

Galant 1800		1.8	85	4	.93- .94	4G93 MPI		1,1	BKR6E-11	2756	14	LPG 1
Galant 1.8	E52A	1.8	93	4	11.92-09.96	4G93		1,1	BKR6E-11	2756	14	LPG 1
Galant 1800		1.8		4	.90- .91	4G37 Cat.		1,1	BPR6ES-11	4824	13	LPG 2
Galant 1800		1.8		4	.92- .96	4G37 Cat.		1,1	BPR7ES-11	7226		BPR8EIX
Galant 1800		1.8		4	.94- .96	4G93		0,8	BK6E	3536		LPG 1
Galant 2000		2.0	100	4	.96- .03	4G63		1,1	BKR6E-11	2756	14	LPG 1
Galant 2.0	E75A	2.0	101	4	11.92-09.96	4G63S		1,1	BKR6E-11	2756	14	LPG 1
Galant 2000		2.0	101	4	.94- .03	4G63 MPI		1,1	BKR6E-11	2756	14	LPG 1
Galant 2000 V6	E74A, E84A	2.0	110	6	05.92-10.94	6A12 MPI 24V		1,1	PFR6J-11	2743		
Galant		2.0		4	.88- .93	4G63 GTi16		0,8	BPR7ES	2023	19	BPR8EIX
Galant		2.0		4	.91- .91	4G63		0,8	BPR6ES	7822	2	LPG 2
Galant 2000		2.0		4	.92- .92	4G63D		0,8	BPR6ES	7822	2	LPG 2
Galant 2000		2.0		4	.92-	Cat.		1,1	BPR7ES-11	7226		BPR8EIX
Galant 2000		2.0		4	.92- .92	4G63		1,1	BPR7ES-11	7226		BPR8EIX
Galant 2000		2.0		4	.93- .96	4G63		0,8	BK6E	3536		LPG 1
Galant		2.0		4	.97- .03	4G63		1,1	BKR6E-11	2756	14	LPG 1
Galant GDI		2.4	110	6	10.98-	4G64 GDI		0,6	IZFR5B	4080		
Galant 2400		2.4		6	.94-	4G64 MPI SOHC		1,1	BKR6E-11	2756	14	LPG 1
Galant 2400		2.4		6	.94-	4G64 MPI DOHC		1,1	BPR6ES-11	4824	13	LPG 2





l kW C
Y
I



Stock-N°

VLINE

LPG/CNG

MITSUBISHI

GALANT

Galant 2500 V6		2.5	125	6	.93-03.97	6G12 24V	1,1	PFR6J-11	2743		
Galant V6 24V		2.5		6	.95- .00	6G73 MPI	1,1	PFR6J-11	2743		
Galant 2500	EC5A	2.5		4	08.96- .03	6A13	0,8	PFR6J	2645		
Galant V6		2.5		6	03.97- .03	6A13	1,1	PFR6G-11	5555		PFR7G

GALLOPER

Galopper		3.0	104	6	.98-12.01	G6AT	1,1	BPR5ES-11	4424		LPG 2
----------	--	-----	-----	---	-----------	------	-----	-----------	------	--	-------

GRANDIS

Grandis		2.4	121	4	04.04-	4G69	0,8	LZFR6AI	3656		
Grandis 2.4	NA4W	2.4	130	4	04.04-12.11	4G69	0,8	LZFR6AI	3656		

I

i 0.7	HA1W	0.66	38	3	02.07-	3B20	0,8	ILKR7B8	1989		
-------	------	------	----	---	--------	------	-----	---------	------	--	--

L200

L200		1.6		4	.92-	4G32	0,9	BPR5ES	7422	6	LPG 2
L200 2.0	K62T	2.0	90	4	09.96-07.01	4G63S	1,1	BKR5E-11	6953	33	LPG 1
L200		2.0		4	.92-	4G63	0,8	BPR6ES	7822	2	LPG 2
L200		2.0		4	- .92	4G63	0,8	BPR7ES	2023	19	BPR8EIX
L200		2.4	82	4	.94-	4G64 MPI	1,1	BCPR6ES-11	7121	11	LPG 3
L200 2.4	K75T	2.4	97	4	09.96-08.04	4G64S	1,1	BKR5E-11	6953	33	LPG 1
L200		2.4	97	4	.99-		1,1	BPR6ES-11	4824	13	LPG 2
L200		2.6	76	4	.93-	4G54/B	1,1	BPR6ES-11	4824	13	LPG 2
L200		2.6		4	.95-	G54B	1,1	BUR6EA-11	5428		
L200		2.6		4	- .92	4G54	1,1	BPR6ES-11	4824	13	LPG 2

L300

L300		1.4		4	.94-	4G33	0,7	BP6ES	7811	4	LPG 2
L300		1.6	51	4	.80- .94	4G32	0,9	BPR5ES	7422	6	LPG 2
L300		2.0	66	4	.92-	4G63 Cat.	0,8	BPR6ES	7822	2	LPG 2
L300		2.0	85	4	07.94-	4G63	0,9	BPR5ES	7422	6	LPG 2
L300		2.0		4	10.94-	4G63 MPI	1,1	BKR5E-11	6953	33	LPG 1
L300		2.0		4	.95-	4G63 FBC	1,1	BKR5E-11	6953	33	LPG 1
L300		2.0		4	- .92	4G63	0,8	BPR6ES	7822	2	LPG 2
L300		2.4	82	4	.92-	4G64 Cat.	1,1	PGR6A-11	3738		

L400

L400 2.0	PA3W	2.0	83	4	05.95-10.02	4G63S	1,1	BKR5E-11	6953	33	LPG 1
L400 2.0	PA3V, PB3V	2.0	85	4	12.94-03.01	4G63S	1,1	BKR5E-11	6953	33	LPG 1
L400		2.0		4	.95-	4G63 MPI	1,1	BKR5E-11	6953	33	LPG 1
L400 2.4	PA4W, PD4W	2.4	94	4	06.96-06.05	4G64S	1,1	BKR5E-11	6953	33	LPG 1
L400		2.4		4	.95-	4G64 MPI	1,1	BKR5E-11	6953	33	LPG 1

LANCER

Lancer 1.3	CB1A	1.3	55	4	06.91-02.95	4G13M	0,8	BP5ES	6511		LPG 2
Lancer 1.3	CB1A	1.3	55	4	06.91-02.95	4G13M	1,1	BPR5ES-11	4424		LPG 2
Lancer 1.3	CK1A	1.3	55	4	06.95-08.03	4G13M	0,8	BP5ES	6511		LPG 2
Lancer 1300		1.3	55	4	11.95-05.01	4G13M MPI	1,1	BPR5ES-11	4424		LPG 2
Lancer		1.3	55	4	03.96- .01	4G13	1,1	BUR6EA-11	5428		
Lancer 1.3	CS1A	1.3	60	4	09.03-06.06	4G13S	1,1	BKR6E-11	2756	14	LPG 1
Lancer 1.3	CS1A	1.3	60	4	07.06-	4G13S	0,8	IFR6S	99404		





e kW C
Y I



Stock-N°

VLINE

LPG/CNG

MITSUBISHI

LANCER

Lancer 1300		1.3		4	.89- .92	4G13	0,8	BPR6ES	7822	2	LPG 2
Lancer 1300		1.3		4	10.92- .01	4G13	0,8	BP5ES	6511	8	LPG 2
Lancer 1300		1.3		4	.97-	4G1	1,1	BPR5ES-11	4424		LPG 2
Lancer 1300		1.3		4	-09.92	4G13 Cat.	0,8	BPR6ES	7822	2	LPG 2
Lancer 1500		1.5	69	4	.93- .00	4G15	0,8	BP5ES	6511	8	LPG 2
Lancer 1.5	CK2A	1.5	69	4	07.96-08.03	4G15M	0,8	BP5ES	6511		LPG 2
Lancer Sportback 1.5	CX2A	1.5	80	4	06.08-	4A91 MIVEC	1,1	ILZFR6C-11K	90428		
Lancer Stufenheck 1.5	CY2A	1.5	80	4	06.08-	4A91 MIVEC	1,1	ILZFR6C-11K	90428		
Lancer 1.5 BiFuel	CY2A	1.5	80	4	01.09-	4A91	1,1	ILZFR6C-11K	90428		
Lancer 1.5 BiFuel	CY2A	1.5	80	4	01.09-	4A91	1,1	LZFR5BI-11	93298		
Lancer Sportback 1.5 BiFuel	CX2A	1.5	80	4	03.10-06.10	4A91	1,1	ILZFR6C-11K	90428		
Lancer 1.5	CY2A	1.5	80	4	07.10-	4A91	1,1	LZFR5BI-11	93298		
Lancer 1500		1.5		4	08.84- .92	4G15	0,8	BPR6ES	7822	2	LPG 2
Lancer 1500		1.5		4	.86- .92	4G15 Cat.	1,1	BPR6ES-11	4824	13	LPG 2
Lancer 1500		1.5		4	.94- .96	4G91 MPI	1,1	BK6E-11	7340		LPG 1
Lancer 1.6	CS3A, CS3W	1.6	72	4	09.03-06.06	4G18	1,1	BKR6E-11	2756	14	LPG 1
Lancer Cargo 1.6	CS3W	1.6	72	4	09.03-06.08	4G18	1,1	BKR6E-11	2756	14	LPG 1
Lancer Cargo 1.6	CS3W	1.6	72	4	09.03-06.08	4G18	0,8	IFR6S	99404		
Lancer 1.6	CS3A, CS3W	1.6	72	4	07.06-	4G18	0,8	IFR6S	99404		
Lancer 1600		1.6	83	4	10.92- .00	4G92 MPI	1,1	BKR6E-11	2756	14	LPG 1
Lancer 1.6	CY1A, CX1A	1.6	86	4	05.10-	4A92	1,1	DILFR5A11	93759		
Lancer 1.6 Mivec	CY1A	1.6	86	4	05.10-	4A92	1,1	LZFR5BI-11	93298		
Lancer 1600		1.6		4	.90-09.92	4G61 DOHC	0,8	BPR6ES	7822	2	LPG 2
Lancer 1600		1.6		4	.94-12.96	4G92 MVV	1,1	BKR5E-11	6953	33	LPG 1
Lancer 1600		1.6		4	.97-	4G9 MVV	1,1	BKR5E-11	6953	33	LPG 1
Lancer 1600		1.6		4	.97- .00	4G9 (not MVV Mager-mix)	1,1	BKR6E-11	2756	14	LPG 1
Lancer 1.8 GTi	CB5A	1.8	103	4	06.92-08.95	4G93 DOHC	1,1	BKR6E-11	2756	14	LPG 1
Lancer 1.8 GTi	CB5A	1.8	103	4	06.92-12.93	4G93 DOHC	1,1	BKR6E-11	2756	14	LPG 1
Lancer 1.8 Mivec	CY3A	1.8	103	4	05.10-	4B10, 4J10	0,8	FR6EI	2687		FR6EI
Lancer Sportback 1.8 Mivec	CX3A	1.8	105	4	06.08-09.11	4B10	1,1	DIFR5C11	1311		
Lancer Sportback 1.8	CX3A	1.8	105	4	07.08-03.09	4B10 MIVEC	0,8	FR6EI	2687		FR6EI
Lancer Stufenheck 1.8	CY3A	1.8	105	4	07.08-03.09	4B10 MIVEC	0,8	FR6EI	2687		FR6EI
Lancer 1.8 BiFuel	CY3A	1.8	105	4	01.09-	4B10	1,1	DIFR5C11	1311		
Lancer Sportback 1.8 BiFuel	CX3A	1.8	105	4	01.09-	4B10	1,1	DIFR5C11	1311		
Lancer 1.8 BiFuel	CY3A	1.8	105	4	01.09-	4B10	0,8	FR6EI	2687		FR6EI
Lancer Sportback 1.8 BiFuel	CX3A	1.8	105	4	01.09-	4B10	0,8	FR6EI	2687		FR6EI
Lancer 1.8 Flex	CY3A	1.8	105	4	01.10-	4B10	1,1	DIFR5C11	1311		
Lancer Stufenheck 1.8	CY3A	1.8	105	4	07.10-09.11	4B10 MIVEC	1,1	DIFR5C11	1311		
Lancer 1.8 Mivec	CY3A	1.8	110	4	11.09-	4B10	1,1	DIFR5C11	1311		
Lancer 1.8 Mivec	CY3A	1.8	110	4	11.09-	4B10	0,8	FR6EI	2687		FR6EI
Lancer 1800		1.8		4	.86- .92	4G37 Cat.	1,1	BPR6ES-11	4824	13	LPG 2
Lancer 1800		1.8		4	.86- .92	4G67	0,8	BPR7ES	2023	19	BPR8EIX
Lancer		1.8		4	.90- .92	4G37 GTi16	0,8	BPR6ES	7822	2	LPG 2
Lancer		1.8		4	.90- .92	4G37 GLXi	1,1	BPR6ES-11	4824	13	LPG 2
Lancer 1800 16V		1.8		4	.93-	4G93 MPI	0,8	BK6E	3536		LPG 1





l kW C
Y
I



Stock-Nº

VLINE

LPG/CNG

MITSUBISHI

LANCER

Lancer		1.8		4	.93-	4G93 GTi16	1,1	BKR6E-11	2756	14	LPG 1
Lancer		2.0	99	4	09.03-	4G63	1,1	IGR6A11	5743		
Lancer 2.0 Mivec	CY4A	2.0	108	4	01.09-	4B11	0,8	FR6EI	2687		FR6EI
Lancer 2.0 Mivec	CY4A	2.0	113	4	03.07-	4B11	0,8	FR6EI	2687		FR6EI
Lancer 2.0 Mivec	CY4A	2.0	113	4	10.07-	4B11	0,8	FR6EI	2687		FR6EI
Lancer Sportback 2.0 Ralliart	CX4A	2.0	177	4	06.08-06.10	4B11-T/C	0,6	ILKR8E6	1422		
Lancer Evolution 2.0	CT9A	2.0	206	4	12.00-03.05	4G63 DOHC	0,8	IGR7A-G	3106		
Lancer Evolution 2.0	CZ4A	2.0	206	4	10.07-06.10	4B11	0,6	ILKR8E6	1422		
Lancer Evolution 2.0	CZ4A	2.0	206	4	07.10-	4B11	0,6	DILKR8B6	91448		
Lancer Evolution 2.0	CT9A	2.0	213	4	08.05-09.07	4G63 DOHC	0,6	ILFR7H	5245		
Lancer Evolution 2.0 FQ-300	CT9A	2.0	225	4	06.03-04.04	4G63 DOHC	0,8	IGR7A-G	3106		
Lancer Evolution 2.0 FQ-300	CT9A	2.0	227	4	08.03-04.04	4G63 DOHC	0,8	IGR7A-G	3106		
Lancer Evolution 2.0 FQ-300	CT9A	2.0	227	4	08.05-10.08	4G63 DOHC	0,6	ILFR7H	5245		
Lancer Evolution 2.0 GT330	CZ4A	2.0	242	4	06.08-	4B11	0,6	DILKR8B6	91448		
Lancer Evolution 2.0	CT9A	2.0	243	4	04.04-08.06	4G63 DOHC	0,8	IGR7A-G	3106		
Lancer Evolution 2.0	CT9A	2.0	246	4	12.03-08.06	4G63 DOHC	0,8	IGR7A-G	3106		
Lancer Evolution 2.0	CT9A	2.0	255	4	06.04-03.05	4G63 DOHC	0,8	IGR7A-G	3106		
Lancer Evolution 2.0	CT9A	2.0	257	4	08.05-10.08	4G63 DOHC	0,6	ILFR7H	5245		
Lancer Evolution 2.0	CZ4A	2.0	257	4	10.11-	4B11	0,6	DILKR8B6	91448		
Lancer Evolution 2.0	CZ4A	2.0	257	4	10.11-	4B11	0,6	ILKR8E6	1422		
Lancer Evolution 2.0 GT360	CZ4A	2.0	264	4	06.08-	4B11	0,6	DILKR8B6	91448		
Lancer Evolution 2.0 FQ-360	CT9A	2.0	273	4	07.06-12.07	4G63 DOHC	0,6	ILFR7H	5245		
Lancer Evolution 2.0	CZ4A	2.0	296	4	06.09-	4B11	0,6	DILKR8B6	91448		
Lancer Evolution 2.0	CZ4A	2.0	296	4	06.09-	4B11	0,6	ILKR8E6	1422		
Lancer Evolution 2.0 FQ-400	CZ4A	2.0	301	4	05.09-06.10	4B11	0,6	ILKR8E6	1422		
Lancer Evolution 2.0 FQ-400	CZ4A	2.0	301	4	07.10-12.10	4B11	0,6	DILKR8B6	91448		
Lancer Evolution 2.0	CT9A	2.0	302	4	10.04-08.06	4G63 DOHC	0,8	IGR7A-G	3106		
Lancer 2000		2.0		4	01.05-	4G94	1,1	BKR5E-11	6953	33	LPG 1

LANCER EVO

Lancer 2.0 EVO		2.0	242	4	06.08-	4B11 FQ30	0,6	ILKR8E6	1422		
Lancer 2.0 EVO		2.0	264	4	06.08-	4B11 FQ60	0,6	ILKR8E6	1422		

LANCER EVO 10

Lancer Evolution X		2.0	217	4	06.08-	4B11-T/C	0,6	ILKR8E6	1422		
--------------------	--	-----	-----	---	--------	----------	-----	---------	------	--	--

LANCER EVO 6

Lancer Evolution VI	CP9A	2.0	206	4	02.98-05.99	4G63 Turbo	0,8	PGR7A	3200		
Lancer Evolution VI Tommi Makinen Edit.	CP9A	2.0		4	01.99-	4G63 Turbo	0,8	IGR7A	6687		

LANCER EVO 7

Lancer Evolution VII	CT9A	2.0	206	4	.01-	4G63 Turbo	0,8	IGR7A-G	3106		
----------------------	------	-----	-----	---	------	------------	-----	---------	------	--	--

LANCER EVO 8

Lancer Evolution VIII	CT9A	2.0	195	4	.04-	4G63 Turbo	0,8	IGR7A-G	3106		
-----------------------	------	-----	-----	---	------	------------	-----	---------	------	--	--

LANCER EVO 9

Lancer Evolution IX	CT9A	2.0	206	4	03.05- .07	4G63-D4 Turbo (VVT) DOHC	0,6	ILFR7H	5245		
---------------------	------	-----	-----	---	------------	--------------------------	-----	--------	------	--	--

LEGNUM

Legnum 2500	EC5A	2.5		4	08.96-	6A13	0,8	PFR6J	2645		
-------------	------	-----	--	---	--------	------	-----	-------	------	--	--





l kW C
Y
I



Stock-N°

VLINE

LPG/CNG

MITSUBISHI

MIRAGE

Mirage	A05A	1.0	52	3	10.12-	3A90	1,1	DILFR6A11	97362		
Mirage	A03A	1.2	59	3	10.12-	3A92	1,1	DILFR6A11	97362		
Mirage 1.3	CA1A	1.3	58	4	12.91-08.95	4G13M	1,1	BPR5ES-11	4424		LPG 2
Mirage		1.5		4	.94-	4G15 MPI	1,1	BPR5ES-11	4424		LPG 2
Mirage 1.6	CA4A	1.6	84	4	12.91-08.95	4G92	1,1	BKR6E-11	2756	14	LPG 1
Mirage 1.6	CC4A	1.6	84	4	03.92-07.93	4G92	1,1	BKR6E-11	2756	14	LPG 1
Mirage 1.6	CC4A	1.6	88	4	12.91-08.95	4G92	1,1	BKR6E-11	2756	14	LPG 1
Mirage		1.6		4	.96-	4G92	1,1	BKR6E-11	2756	14	LPG 1
Mirage		1.8		4	.94-	4G93 MPI	1,1	BKR5E-11	6953	33	LPG 1

MONTERO

Montero I.O 1.8	H76W	1.8	84	4	03.01-02.05	4G93	1,1	BKR5E-11	6953	33	LPG 1
Montero Sport 3.0	K96W	3.0	125	6	06.00-02.03	6G72 DOHC	1,1	PFR5J-11	4642		
Montero 3.0	V23W, V43W	3.0	130	6	11.97-04.00	6G72SOHC	1,1	PFR6J-11	2743		
Montero Sport 3.0	K96W	3.0	130	6	11.98-09.01	6G72 DOHC	1,1	PFR5J-11	4642		
Montero V6 3000		3.0		6	.91-	6G72	1,1	BPR5ES-11	4424		LPG 2
Montero 3.5	V45W	3.5	153	6	11.93-02.00	6G74 DOHC	1,1	PFR5J-11	4642		

OUTLANDER I

Outlander I 2.0	CU2W	2.0	93	4	05.03-10.06	4G63	1,1	IGR6A11	5743		
Outlander I 2.0	CU2W	2.0	100	4	05.03-10.06	4G63	1,1	IGR6A11	5743		
Outlander I 2.0 Turbo	CU2W	2.0	148	4	04.04-06.04	4G63 Turbo	1,1	IGR6A11	5743		
Outlander I 2.0 Turbo	CU2W	2.0	177	4	05.03-10.06		1,1	IGR6A11	5743		
Outlander I 2.4	CU5W	2.4	102	4	05.03-10.06		0,8	LZFR6AI	3656		
Outlander I 2.4	CU5W	2.4	118	4	05.03-10.06	4G69	0,8	LZFR6AI	3656		

OUTLANDER II

Outlander II 2.0	CW4W	2.0	108	4	11.06-08.13	4B11	1,1	DIFR6C11	1312		
Outlander 2.4 Mivec	CW5W	2.4	125	4	11.06-12.13	4B12	1,1	DIFR5C11	1311		
Outlander II 2.4	CW5W	2.4	125	4	06.07-08.13	4B12	0,8	FR5EI	1313		FR6EI
Outlander 2.4 Mivec	CW5W	2.4	125	4	06.07-08.13	4B12	1,1	DIFR5C11	1311		
Outlander II 2.4 Flex Fuel	CW5W	2.4	125	4	09.07-06.10	4B12	0,8	FR5EI	1313		FR6EI
Outlander 2.4 Flex	CW5W	2.4	125	4	09.07-06.10	4B12	1,1	DIFR5C11	1311		
Outlander II 3.0	CW6W	3.0	162	6	11.06-08.13	6B31	0,8	ILKR7B8	1989		
Outlander 3.0 Mivec	CW6W	3.0	164	6	01.11-08.13	6B31	0,8	ILKR7B8	1989		
Outlander 3.0 Mivec	CW6W	3.0	169	6	09.10-12.12	6B31	0,8	ILKR7B8	1989		

OUTLANDER III

Outlander III 2.0 Hybrid	GG2W	2.0	89	4	12.12-	4B11	0,8	FR6EI	2687		FR6EI
Outlander III 2.0	GF7W	2.0	107	4	10.12-	4J11	1,1	DILKR6D11G	95264		
Outlander III 2.0	GF7W	2.0	110	4	08.12-	4J11	1,1	DILKR6D11G	95264		
MITSUBISHI Outlander III 2.4 Plug-In Hybrid	GG3W	2.4	99	4	09.18-	4B12	1,1	DIFR5E11	91112		
Outlander 2.4 Mivec	GF3W	2.4	123	4	10.12-	4B12	0,8	FR5EI	1313		FR6EI
Outlander 3.0 Mivec	GF4W	3.0	165	6	04.14-	6B31	1,1	DILKR7C11	94731		
Outlander III 3.0 Mivec	GF4W	3.0	167	6	08.12-	6B31	1,1	DILKR7C11	94731		
Outlander 3.0 Mivec	GF4W	3.0	167	6	08.12-	6B31	1,1	DILKR7C11	94731		
Outlander III 3.0 Mivec	GF4W	3.0	169	6	03.14-	6B31	1,1	DILKR7C11	94731		

PAJERO

Pajero 2400		2.4		4	03.91-	4G64	1,1	BPR6ES-11	4824	13	LPG 2
-------------	--	-----	--	---	--------	------	-----	-----------	------	----	-------





el kW C Y I



Stock-No

VLINE

LPG/CNG

MITSUBISHI

PAJERO

Pajero	2.4		4	.97-	4G64	1,1	BPR6ES-11	4824	13	LPG 2
Pajero 2600	2.6		4	.92-		1,1	BP6ES-11	1212		LPG 2
Pajero	3.0	130	6	.97-	6G72 24Ventiler	1,1	PFR6J-11	2743		
Pajero 3000 V6	3.0		6	.89-	6G72	1,1	BPR5ES-11	4424		LPG 2
Pajero	3.0		6	.97-	6G72 12Ventiler	1,1	BPR5ES-11	4424		LPG 2
Pajero Sport	3.0		6	.99-	6G72 24Ventiler	1,1	PFR6J-11	2743		
Pajero	3.5	143	6	.97-	6G74	1,1	PFR5J-11	4642		
Pajero GDI V60	3.5	149	6	04.00-	V6	0,6	IZFR5B	4080		
Pajero 3500 V6	3.5	153	6	04.94- .97	6G74 DOHC	1,1	PFR6J-11	2743		
Pajero 3.8 V6 GDI	V87W, V97W	3.8	182	6	02.10-	6G75	0,8	IFR6B-K	4867	
Pajero 3.8 V6 GDI	V87W, V97W	3.8	184	6	11.06-	6G75	0,8	IFR6B-K	4867	

PAJERO I

Pajero Pinin 1.8	H66W, H76W	1.8	84	4	03.01-02.05	4G93	1,1	BKR5E-11	6953	33	LPG 1
Pajero Sport 3.0	K96W	3.0	123	6	03.03-12.07	6G72SOHC	1,1	PFR5J-11	4642		
Pajero Sport 3.0	K96W	3.0	123	6	01.08-12.09	6G72SOHC	1,1	IFR6E11	6741		
Pajero Sport 3.0	K96W	3.0	125	6	10.01-12.07	6G72 DOHC	1,1	PFR5J-11	4642		
Pajero Sport 3.0	K96W	3.0	125	6	01.08-12.09	6G72 DOHC	1,1	IFR6E11	6741		
Pajero Sport 3.0	K96W	3.0	130	6	11.98-09.01	6G72 DOHC	1,1	PFR5J-11	4642		

PAJERO II

Pajero 2.6	V32W	2.6	76	4	03.91-10.97	4G54	0,8	BP5ES	6511		LPG 2
Pajero 3.0	V23W, V43W	3.0	130	6	06.97-04.00	6G72SOHC	1,1	PFR6J-11	2743		
Pajero Sport 3.0 Mivec	KH6W	3.0	162	6	07.08-12.15	6B31	0,8	ILKR7B8	1989		
Pajero 3.5	V45W	3.5	153	6	11.93-02.00	6G74 DOHC	1,1	PFR5J-11	4642		
Pajero Sport 3.5	KH9W	3.5	153	6	09.08-	6G74SOHC	1,1	IFR5E11	7994		IFR6E11

PAJERO III

Pajero 3.0	V73W	3.0	125	6	10.01-01.07	6G72 DOHC	0,9	BKR6E	6962	28	LPG 1
Pajero Sport 3.0 Mivec	KS5W	3.0	154	6	08.15-	6B31	1,1	DILKR7C11	94731		

PAJERO IV

Pajero 3.0	V93W	3.0	128	6	01.16-	6G72SOHC	1,1	DIFR6C11	1312		
Pajero 3.0	V93W	3.0	131	6	02.07-	6G72SOHC	1,1	DIFR6C11	1312		
Pajero 3.0 (not for Russia)	V93W	3.0	131	6	02.07-	6G72SOHC	0,8	IFR6B-K	4867		
Pajero 3.8	V87W, V97W	3.8	182	6	02.10-	6G75	0,8	IFR6B-K	4867		

PAJERO PININ

Pajero Pinin	H66W, H67W	1.8	88	4	.00-	4G93 GDI	0,6	IZFR6B	3116		
Pajero Pinin	H76W, H77W	2.0	95	4	09.00-	4G94 GDI	0,6	IZFR5B	4080		

SANTAMO

Santamo		2.0	102	4	.99-	DOHC, SOHC	1,1	BP6ES-11	1212		LPG 2
---------	--	-----	-----	---	------	------------	-----	----------	------	--	-------

SHOGUN

Shogun Pinin 1.8	H66W	1.8	84	4	03.01-02.05	4G93	1,1	BKR5E-11	6953	33	LPG 1
Shogun Sport Van 3.0	K96W	3.0	125	6	12.99-01.08	6G72SOHC	1,1	IFR6E11	6741		
Shogun Sport Van 3.0	K96W	3.0	125	6	12.99-01.08	6G72SOHC	1,1	PFR5J-11	4642		
Shogun Sport 3.0	K96W	3.0	125	6	10.01-12.07	6G72 DOHC	1,1	PFR5J-11	4642		
Shogun Sport 3.0	K96W	3.0	125	6	01.08-12.08	6G72 DOHC	1,1	IFR6E11	6741		
Shogun Sport 3.0	K96W	3.0	130	6	11.98-09.01	6G72 DOHC	1,1	PFR5J-11	4642		
Shogun		3.0		6	.91- .94	6G72	1,1	BPR5ES-11	4424		LPG 2





l kW C
Y I



Stock-N°

VLINE

LPG/CNG

MITSUBISHI

SHOGUN

Shogun	3.0		6	.94-	6G72	1,1	PFR6J-11	2743		
Shogun	3.5		6	.91-	6G74	1,1	PFR5J-11	4642		
Shogun	3.5		6	.00-		0,8	IZFR5B	4080		

SHOGUN PININ

Shogun PININ	1.8		4	.00-	4G93 GDI	0,8	IZFR6B	3116		
Shogun PININ	2.0		4	.00-	4G94 GDI	0,8	IZFR5B	4080		

SIGMA

Sigma V6	3.0		6	.91- .93	6G72 SOHC	1,1	BPR6ES-11	4824	13	LPG 2
Sigma V6	3.0		6	.91- .93	6G72 DOHC 24V	1,1	PFR6J-11	2743		
Sigma 3000	3.0		6	.93- .96	6G72 MPI V6	1,1	BPR6ES-11	4824	13	LPG 2
Sigma 3000	3.0		6	.94- .96	6G72 MPI V6-24V	1,1	PFR6J-11	2743		

SPACE GEAR

Space Gear	2.0	83	4	04.95- .01	4G63 MPI	1,1	BKR5E-11	6953	33	LPG 1
Space Gear 2.0	PA3W	2.0	83	08.96-05.00	4G63S	1,1	BKR5E-11	6953	33	LPG 1
Space Gear	2.0		4	.97- .01	4G69	1,1	BKR5E-11	6953	33	LPG 1
Space Gear 2.4	PA4W	2.4	97	12.94-03.01	4G64S	1,1	BKR5E-11	6953	33	LPG 1
Space Gear	2.4	97	4	04.95- .01	4G64 MPI	1,1	BKR5E-11	6953	33	LPG 1
Space Gear 2.4	PD4W	2.4	97	05.95-05.00	4G64S	1,1	BKR5E-11	6953	33	LPG 1

SPACE RUNNER

Space Runner 1.8	N11W	1.8	85	4	06.91-09.99	4G93	0,9	BKR6E	6962	28	LPG 1
Space Runner 1.8	N11W	1.8	90	4	06.91-09.99	4G93	0,9	BKR6E	6962	28	LPG 1
Space Runner 1800		1.8	90	4	09.91- .92	4G93	1,1	BKR6E-11	2756	14	LPG 1
Space Runner 1800		1.8	90	4	.91- .99	4G93 MPI	1,1	BKR6E-11	2756	14	LPG 1
Space Runner 1800		1.8		4	.94- .99	4G93	0,8	BK6E	3536		LPG 1
Space Runner		1.8		4	.97- .99	4G93	1,1	BKR6E-11	2756	14	LPG 1
Space Runner 2.0	N63W	2.0	98	4	05.00-08.02	4G63S	1,1	BKR6E-11	2756	14	LPG 1
Space Runner		2.0	100	4	.99-08.02	4G63 MPI	1,1	BKR6E-11	2756	14	LPG 1
Space Runner 2.4 GDI	N64W	2.4	108	4	10.99-04.03	4G64 DOHCB	0,6	IZFR5B	4080		
Space Runner GDI		2.4	110	4	.99-	4G64 GDI	0,6	IZFR5B	4080		

SPACE STAR

Space Star		1.0	52	3	10.12-	3A90	1,1	DILFR6A11	97362		
Space Star 1.2 Mivec	A03A	1.2	59	3	10.12-	3A92	1,1	DILFR6A11	97362		
Space Star 1.3	DG1A	1.3	61	4	12.98-12.04	4G13S	1,1	BKR6E-11	2756	14	LPG 1
Space Star 1.3	DG1A	1.3	63	4	06.98-07.00	4G13S	1,1	BKR6E-11	2756	14	LPG 1
Space Star 1.3		1.3	63	4	12.98-05.00	4G13	1,1	BKR5E-11	6953	33	LPG 1
Space Star 1.3		1.3	63	4	06.00-12.04	4G13	1,1	BKR6E-11	2756	14	LPG 1
Space Star 1.6		1.6	72	4	04.01-12.04	4G18	1,1	BKR6E-11	2756	14	LPG 1
Space Star 1.6	DG3A	1.6	72	4	04.01-12.04	4G18	1,1	BKR6E-11	2756	14	LPG 1
Space Star 1.8 MPI		1.8	82	4	08.02-12.04	4G93	0,6	IZFR6B	3116		
Space Star 1.8	DG5A	1.8	82	4	08.02-12.04	4G93	1,1	BKR5E-11	6953	33	LPG 1
Space Star 1.8 GDI		1.8	87	4	06.98-12.04	4G93 GDI	0,6	IZFR6B	3116		
Space Star 1.8 GDI		1.8	90	4	06.98-12.04	4G93 GDI	0,6	IZFR6B	3116		

SPACE WAGON

Space Wagon 1800		1.8		4	.84- .91	4G37	0,8	BPR6ES	7822	2	LPG 2
Space Wagon 1800		1.8		4	09.91- .93	4G93	1,1	BKR6E-11	2756	14	LPG 1





l kW C
Y
I



Stock-N°

VLINE

LPG/CNG

MITSUBISHI

SPACE WAGON

Space Wagon 1800		1.8		4	.94-	4G93	0,8	BK6E	3536		LPG 1
Space Wagon 1800		1.8		4	.94-	4G93 MPI	1,1	BKR6E-11	2756	14	LPG 1
Space Wagon 2.0	N83W	2.0	80	4	12.98-06.02	4G63S	1,1	BKR6E-11	2756	14	LPG 1
Space Wagon 2000		2.0	98	4	.92- .00	4G63 MPI Cat.	1,1	BKR6E-11	2756	14	LPG 1
Space Wagon 2.0 GDi	N83W	2.0	98	4	10.98-01.04	4G63S	1,1	BKR6E-11	2756	14	LPG 1
Space Wagon Gdi (N5.)		2.0	98	4	02.02-	4G94	1,1	HB6BIX-11P	5705		
Space Wagon 2000 4WD		2.0		4	.89-		0,8	BPR7ES	2023	19	BPR8EIX
Space Wagon 2000		2.0		4	.89- .91	4G63 Cat.	1,1	BPR7ES-11	7226		BPR8EIX
Space Wagon		2.0		4	.97-	4G63	1,1	BKR5E-11	6953	33	LPG 1
Space Wagon 2.4	N34W	2.4	85	4	04.92-05.95	4G64S	1,1	BKR6E-11	2756	14	LPG 1
Space Wagon 2.4	N34W	2.4	85	4	04.92-05.95	4G64S	1,1	BPR6ES-11	4824	13	LPG 2
Space Wagon 2.4	N34W	2.4	102	4	02.92-10.98	4G64S	1,1	BPR6ES-11	4824	13	LPG 2
Space Wagon GDI	N84W, N94W	2.4	110	4	10.98-01.04	4G64 GDI	0,6	IZFR5B	4080		
Space Wagon 2400		2.4		4	.93- .95	4G64 Cat.	1,1	BKR6E-11	2756	14	LPG 1

STARION

Starion 2600 Turbo		2.6			.89-	4G54 Cat.	1,1	BPR6ES-11	4824	13	LPG 2
--------------------	--	-----	--	--	------	-----------	-----	-----------	------	----	-------

TREDIA

Tredia		1.6		4	.86-		0,9	BPR5ES	7422	6	LPG 2
--------	--	-----	--	---	------	--	-----	--------	------	---	-------

MORGAN

4/4

4/4		1.6	71	4	01.82- .93	CVH Ford	0,8	BCPR6ES	2330	12	LPG 3
4/4		1.8	89	4	02.93-	Zetec 16V	1,3	PTR5A-13	2467	25	LPG 4
4/4		1.8		4	.94- .98	FORD ZETEC	1,0	PTR5A-10	5055		

AERO 8

Aero 8		4.4	210	8	.00-	BMW M62B44	1,5	BKR6EQUP	3199	30	LPG 1
--------	--	-----	-----	---	------	------------	-----	----------	------	----	-------

PLUS 4

Plus 4		2.0	98	4	09.87- .92	M16i	0,8	BCPR6ES	2330	12	LPG 3
Plus 4		2.0	99	4	09.92- .96	T16	0,8	BCPR6ES	2330	12	LPG 3

PLUS 8

Plus 8		3.5	136	8	01.90- .01	V8 Rover Cat.	0,7	BP6ES	7811	4	LPG 2
Plus 8		3.5	142	8	01.90- .01	V8 Rover	0,7	BP6ES	7811	4	LPG 2
Plus 8		3.9	140	8	01.90-09.03	V8 Kat Rover	0,8	BPR6ES	7822	2	LPG 2
Plus 8		4.0		8	.01-	ROVER V8	1,1	PFR6N-11	3546		LPG 1
Plus 8		4.6		8	.97- .99	ROVER V8	1,1	PFR6N-11	3546		LPG 1

NISSAN

100 NX B13

100 NX 1.6	B13	1.6	66	4	10.90- .95	GA16DE Cat.	0,9	BKR6E	6962	28	LPG 1
100 NX 1.6	B13	1.6	66	4	10.90- .93	GA16DS Cat.	0,9	BKR6E	6962	28	LPG 1
100NX 1.6	B13	1.6	66	4	10.90-10.94	GA16DS	0,8	BKR5E	7938	35	LPG 1
100NX 1.6	B13	1.6	66	4	10.90-10.94	GA16DS	0,9	BKR7E	6097		BKR8EIX
100NX 1.6	B13	1.6	75	4	10.92-07.96	GA16DE	0,9	BKR6E	6962	28	LPG 1
100NX 1.6	B13	1.6	75	4	10.92-07.96	GA16DE	0,9	BKR7E	6097		BKR8EIX
100 NX 1.6 SR	B13	1.6	75	4	09.93- .94	GA16DE	0,8	BKR5E	7938	35	LPG 1
100 NX 2.0 GTI	B13	2.0	105	4	10.90- .95	SR20DE Cat.	0,9	BKR6EY	3696		LPG 1





e kW C
Y
I



Stock-N°

VLINE

LPG/CNG

NISSAN

100 NX B13

100NX 2.0 GTi	B13	2.0	105	4	10.90-09.95	SR20DE	0,9	BKR5EY	7390		LPG 1
100NX 2.0 GTi	B13	2.0	105	4	10.90-09.95	SR20DE	0,9	BKR7EY	2270		

200 SX TURBO S13

200 SX Turbo S13		1.8	124	4	.89- .93	CA18DET	1,1	PFR6A-11	4045		
------------------	--	-----	-----	---	----------	---------	-----	----------	------	--	--

200 SX TURBO S14

200 SX Turbo S14		2.0	147	4	08.94-12.99	SR20DET	0,9	PFR6B-9	3100		PFR7B
------------------	--	-----	-----	---	-------------	---------	-----	---------	------	--	-------

200 SX TURBO S30

200 SX Turbo S30		1.8	124	4	09.88- .93	CA18DET Cat.	1,1	PFR6A-11	4045		
200 SX Turbo S30		1.8	129	4	09.88- .93	CA18DET	1,1	BCPR6ES-11	7121	11	LPG 3

300 ZX BITURBO Z32

300 ZXTT Biturbo Z32	Z32	3.0	197	6	.90- .95	VG30DETT	1,1	PFR6B-11C	2684		
300 ZX Biturbo Z32	Z32	3.0	206	6	01.90- .95	VG30DETT Cat.	1,1	PFR6B-11C	2684		

300 ZX Z32

300 ZX Z32	Z32	3.0		6	.90- .96	VG30DE	1,1	PFR6B-11	4014		PFR7B
------------	-----	-----	--	---	----------	--------	-----	----------	------	--	-------

350 Z

350 Z 3.5 CVTC	Z33	3.5	206	6	10.02-06.06	VQ35DE	1,1	PLFR6A-11	7654		LPG 7
350 Z Z33	Z33	3.5	206	6	10.03-06.06	VQ35DE	1,1	PLFR5A-11	6240		LPG 7
350 Z 3.5 CVTC	Z33	3.5	206	6	10.03-12.07	VQ35DE	1,1	PLFR6A-11	7654		LPG 7
350 Z Roadster Z33	Z33	3.5	206	6	11.04-08.05	VQ35DE	1,1	PLFR5A-11	6240		LPG 7
350 Z 3.5 CVTC	Z33	3.5	214	6	09.02-01.07	VQ35DE	1,1	PLFR5A-11	6240		LPG 7
350 Z 3.5 CVTC	Z33	3.5	214	6	09.02-01.07	VQ35DE	1,1	PLFR6A-11	7654		LPG 7
350 Z 3.5 CVTC	Z33	3.5	221	6	09.02-12.08	VQ35DE	1,1	PLFR6A-11	7654		LPG 7
350 Z 3.5 CVTC	Z33	3.5	221	6	11.04-01.07	VQ35DE	1,1	PLFR6A-11	7654		LPG 7
350 Z Z33	Z33	3.5	221	6	04.06-01.07	VQ35DE	1,1	PLFR5A-11	6240		LPG 7
350 Z Roadster Z33	Z33	3.5	221	6	.06-01.07	VQ35DE	1,1	PLFR5A-11	6240		LPG 7
350 Z Z33	Z33	3.5	230	6	09.05-	VQ35HR	1,1	DF7H-11B	1317		

370 Z

370 Z Z34	Z34	3.7	241	6	06.09-	VQ37VHR	1,1	DF8H-11B	1305		
370 Z Z34	Z34	3.7	243	6	06.09-	VQ37VHR	1,1	DF8H-11B	1305		

ALMERA N15

Almera 1.4	N15	1.4	55	4	07.95-03.00	GA14DE	0,9	BKR6E	6962	28	LPG 1
Almera 1.4	N15	1.4	55	4	07.95-03.00	GA14DE	0,9	BKR7E	6097		BKR8EIX
Almera 1.4	N15	1.4	55	4	09.95-04.00	GA14DE	0,8	BKR5E	7938	35	LPG 1
Almera 1.4	N15	1.4	64	4	07.95-03.00	GA14DE	0,9	BKR6E	6962	28	LPG 1
Almera 1.4	N15	1.4	64	4	07.95-03.00	GA14DE	0,9	BKR7E	6097		BKR8EIX
Almera 1.6	N15	1.6	66	4	07.95-03.00	GA16DE	0,9	BKR6E	6962	28	LPG 1
Almera 1.6	N15	1.6	66	4	07.95-03.00	GA16DE	0,9	BKR7E	6097		BKR8EIX
Almera 1.6	N15	1.6	66	4	09.95-	GA16DE	0,8	BKR5E	7938	35	LPG 1
Almera 1.6	N15	1.6	66	4	.95- .00	QG15DE	1,1	BKR5E-11	6953	33	LPG 1
Almera 1.6	N15	1.6	73	4	07.95-03.00	GA16DE	0,9	BKR6E	6962	28	LPG 1
Almera 1.6	N15	1.6	73	4	07.95-03.00	GA16DE	0,9	BKR7E	6097		BKR8EIX
Almera 1.6	N15	1.6	73	4	09.95-07.00	GA16DE	0,9	BKR6E	6962	28	LPG 1
Almera 1.6	N15	1.6	73	4	09.95-07.00	GA16DE	0,9	BKR7E	6097		BKR8EIX
Almera 1.6	N15	1.6	75	4	07.95-03.00	GA16DE	0,8	BKR5E	7938	35	LPG 1
Almera 1.6	N15	1.6	75	4	07.95-03.00	GA16DE	0,9	BKR6E	6962	28	LPG 1





l kW C
Y
I



Stock-N°

VLINE

LPG/CNG

NISSAN

ALMERA N15

Almera 1.6	N15	1.6	75	4	07.95-03.00	GA16DE	0,9	BKR7E	6097		BKR8EIX
Almera Gti	N15	2.0	105	4	.95-04.00	SR20DE	1,1	BKR5EY-11	2355		LPG 1
Almera 2.0 GTi	N15	2.0	105	4	07.96-03.00	SR20DE	1,1	BKR6EY-11	4368		LPG 1

ALMERA N16

Almera 1.5	N16E	1.5	66	4	01.00-11.06	QG15DE	1,1	BKR4E-11	5424		
Almera 1.5	N16E	1.5	66	4	01.00-11.06	QG15DE	1,1	BKR6E-11	2756	14	LPG 1
Almera 1.5	N16E	1.5	66	4	01.00-11.06	QG15DE	1,1	LFR5A-11	6376		LPG 7
Almera 1.5	N16E	1.5	66	4	01.00-11.06	QG15DE	1,1	PLFR5A-11	6240		LPG 7
Almera 1.5	N16E	1.5	66	4	01.00-11.06	QG15DE	1,1	PLFR6A-11	7654		LPG 7
Almera 1.5	N16	1.5	66	4	02.00-09.02	QG15DE	1,1	BKR5E-11	6953	33	LPG 1
Almera 1.5	N16, N16E	1.5	66	4	04.00-11.06	QG15DE	1,1	BKR4E-11	5424		
Almera 1.5	N16, N16E	1.5	66	4	04.00-11.06	QG15DE	1,1	BKR6E-11	2756	14	LPG 1
Almera 1.5	N16, N16E	1.5	66	4	04.00-11.06	QG15DE	1,1	LFR5A-11	6376		LPG 7
Almera 1.5	N16, N16E	1.5	66	4	04.00-11.06	QG15DE	1,1	PLFR5A-11	6240		LPG 7
Almera 1.5	N16, N16E	1.5	66	4	04.00-11.06	QG15DE	1,1	PLFR6A-11	7654		LPG 7
Almera 1.5	N16	1.5	72	4	10.02-	QG15DE	1,1	LFR5A-11	6376		LPG 7
Almera 1.5	N16E	1.5	72	4	12.02-09.06	QG15DE	1,1	BKR4E-11	5424		
Almera 1.5	N16E	1.5	72	4	12.02-09.06	QG15DE	1,1	BKR5E-11	6953	33	LPG 1
Almera 1.5	N16E	1.5	72	4	12.02-09.06	QG15DE	1,1	BKR6E-11	2756	14	LPG 1
Almera 1.5	N16E	1.5	72	4	12.02-09.06	QG15DE	1,1	PLFR5A-11	6240		LPG 7
Almera 1.5	N16E	1.5	72	4	12.02-09.06	QG15DE	1,1	PLFR6A-11	7654		LPG 7
Almera 1.8	N16E	1.8	84	4	01.00-11.02	QG18DE	1,1	BKR4E-11	5424		
Almera 1.8	N16E	1.8	84	4	01.00-11.02	QG18DE	1,1	BKR6E-11	2756	14	LPG 1
Almera 1.8	N16	1.8	84	4	02.00-09.02	QG18DE	1,1	BKR5E-11	6953	33	LPG 1
Almera 1.8	N16, N16E	1.8	84	4	04.00-11.02	QG18DE	1,1	BKR4E-11	5424		
Almera 1.8	N16, N16E	1.8	84	4	04.00-11.02	QG18DE	1,1	BKR6E-11	2756	14	LPG 1
Almera 1.8	N16	1.8	85	4	10.02-	QG18DE	1,1	LFR5A-11	6376		LPG 7
Almera 1.8	N16E	1.8	85	4	12.02-09.06	QG18DE	1,1	BKR4E-11	5424		
Almera 1.8	N16E	1.8	85	4	12.02-09.06	QG18DE	1,1	BKR5E-11	6953	33	LPG 1
Almera 1.8	N16E	1.8	85	4	12.02-09.06	QG18DE	1,1	BKR6E-11	2756	14	LPG 1

ALMERA TINO

Almera Tino ATV10		1.8	84	4	.00- .02	QG18DE	1,1	BKR5E-11	6953	33	LPG 1
Almera Tino ATV10		1.8	85	4	.03-	QG18DE	1,1	LFR5A-11	6376		LPG 7
Almera Tino ATV10		2.0	100	4	.00- .02	SR20DE	1,1	PFR6G-11	5555		PFR7G

ALMERA TINO V10M

Almera Tino 1.8	V10M	1.8	84	4	04.00-05.03	QG18DE	1,1	BKR4E-11	5424		
Almera Tino 1.8	V10M	1.8	84	4	04.00-05.03	QG18DE	1,1	BKR6E-11	2756	14	LPG 1
Almera Tino 1.8	V10M	1.8	85	4	06.03-11.05	QG18DE	1,1	BKR4E-11	5424		
Almera Tino 1.8	V10M	1.8	85	4	06.03-11.05	QG18DE	1,1	BKR6E-11	2756	14	LPG 1
Almera Tino 2.0	V10M	2.0	100	4	04.00-05.03	SR20DE	1,1	PFR5G-11	2647		
Almera Tino 2.0 (For cold climate zones)	V10M	2.0	100	4	04.00-05.03	SR20DE	1,1	PFR7G-11	2380		

BLUEBIRD

Bluebird		1.8		4	.90-	CA18NS, CA18S	0,8	BCP5ES	7496	16	LPG 3
----------	--	-----	--	---	------	---------------	-----	--------	------	----	-------

BLUEBIRD T12

Bluebird T12		2.0	77	4	12.85-	CA20S	0,8	BCPR6ES	2330	12	LPG 3
--------------	--	-----	----	---	--------	-------	-----	---------	------	----	-------





e kW C
Y
I



Stock-No°

VLINE

LPG/CNG

NISSAN

BLUEBIRD U13

Bluebird U13	1.6		4	.94-	CA16NS	0,8	BCP5ES	7496	16	LPG 3
Bluebird U13	2.0		4	.93-	CA20S	0,7	BCP6ES	4930	17	LPG 3
Bluebird U13	2.0		4	.93-	CA20E	1,1	BCPR6ES-11	7121	11	LPG 3

CABSTAR

Cabstar F23/H41	1.6		4	.93-	Z16	0,8	BP5ES	6511	8	LPG 2
Cabstar F23/H41	2.0		4	.93-	Z20	0,8	BP5ES	6511	8	LPG 2
Cabstar F23/H41	2.4		4	.93-	Z24	0,7	BP6ES	7811	4	LPG 2

CARAVAN

Caravan	2.0	120	4	01.01-	KA20DE (DOHC)	1,1	BKR5E-11	6953	33	LPG 1
Caravan	2.4		4	01.01-	KA24DE (DOHC)	1,1	BKR5E-11	6953	33	LPG 1

CUBE

Cube 1.6 16V	Z12	1.6	81	4	03.10-	HR16DE	1,1	LZKAR6AP-11	6643	
--------------	------------	-----	----	---	--------	--------	-----	-------------	------	--

EVALIA

Evalia 1.6 16V	M20M	1.6	81	4	07.10-	HR16DE	1,1	PLZKAR6A-11	5118	51
----------------	-------------	-----	----	---	--------	--------	-----	-------------	------	----

GLORIA

Gloria (MY34)		2.5		4	06.99-06.00	VQ25DD Ne-Di	1,1	PFR5P-11	4341	
---------------	--	-----	--	---	-------------	--------------	-----	----------	------	--

GT-R

GT-R 3.8	R35	3.8	353	6	12.08-	VR38DETT	0,8	DILKAR8A8	93026	
GT-R 3.8	R35	3.8	357	6	12.08-	VR38DETT	0,8	DILKAR8A8	93026	
GT-R 3.8	R35	3.8	390	6	02.11-	VR38DETT	0,8	DILKAR8A8	93026	
GT-R 3.8	R35	3.8	397	6	01.11-	VR38DETT	0,8	DILKAR8A8	93026	
GT-R 3.8	R35	3.8	404	6	07.11-	VR38DETT	0,8	DILKAR8A8	93026	
GT-R 3.8	R35	3.8	408	6	11.16-	VR38DETT	0,8	DILKAR8A8	93026	
GT-R 3.8	R35	3.8	419	6	03.16-	VR38DETT	0,8	DILKAR8A8	93026	
GT-R 3.8	R35	3.8	441	6	07.14-	VR38DETT	0,8	DILKAR8A8	93026	

JUKE

Juke 1.6	F15E	1.6	69	4	01.13-	HR16DE	1,1	DILZKAR6A11	91691	
Juke 1.6 LPG	F15E	1.6	80	4	09.18-	HR16DE	1,1	DILZKAR6A11	91691	
Juke 1.6 CVTC	F15E	1.6	83	4	07.18-	HR16DE	1,1	DILZKAR6A11	91691	
Juke 1.6 LPG	F15E	1.6	85	4	01.12-	HR16DE	1,1	DILZKAR6A11	91691	
Juke 1.6	F15E	1.6	86	4	06.10-	HR16DE	1,1	DILZKAR6A11	91691	
Juke 1.6	F15E	1.6	140	4	06.10-	MR16DDT	0,9	DILKAR7C9H	91215	
Juke 1.6 4x4	F15E	1.6	140	4	06.10-	MR16DDT	0,9	DILKAR7C9H	91215	
Juke 1.6 DIG-T	F15E	1.6	147	4	11.12-	MR16DDT	0,9	DILKAR7C9H	91215	
Juke 1.6 DIG-T (For OE-No. 224011TT1C)	F15E	1.6	157	4	08.14-	MR16DDT	0,9	DILKAR7E9HS	95003	
Juke 1.6 DIG-T (For OE-No. 224011TT1C)	F15E	1.6	160	4	08.14-	MR16DDT	0,9	DILKAR7E9HS	95003	

KUBISTAR

Kubistar 1.2		1.1	44	4	08.03-08.05	D7F726, D7F764	0,8	BKR5EK	7956	23	LPG 1
Kubistar 1.2 16V		1.2	55	4	12.03-10.09	D4F712, D4F730	0,8	LZKAR7A	6799	54	
Kubistar 1.6 16V		1.6	70	4	09.03-	K4M720, K4M744, K4M745, K4M748	0,9	BKR6E	6962	28	LPG 1

MARCH

March 1.0	K11E	1.0	40	4	03.98-08.00	CG10DE	1,1	BKR4E-11	5424		
March 1.0	K11E	1.0	40	4	03.98-08.00	CG10DE	1,1	BKR6E-11	2756	14	LPG 1
March 1.3	K11E	1.3	55	4	08.92-08.00	CG13DE	1,1	BKR4E-11	5424		
March 1.3	K11E	1.3	55	4	08.92-08.00	CG13DE	1,1	BKR6E-11	2756	14	LPG 1





l kW C
Y
I



Stock-N°

VLINE

LPG/CNG

NISSAN

MAXIMA A32

Maxima QX A32	2.0	103	6	.95-	.00	VQ20DE	1,1	PFR6G-11	5555		PFR7G
Maxima QX A32	3.0	141	6	.95-	.00	VQ30DE	1,1	PFR6G-11	5555		PFR7G

MAXIMA A33

Maxima A33	2.0	103	6	.00-		VQ20DE	1,1	PFR6G-11	5555		PFR7G
Maxima A33	3.0	147	6	.00-		VQ30DE	1,1	PFR6G-11	5555		PFR7G

MICRA I

Micra I 1.0	K10	1.0	37	4	12.82-	.92	MA10S	0,9	BPR5ES	7422	6	LPG 2
Micra I 1.0	K10	1.0	40	4	.93-		MA10	0,9	BPR5ES	7422	6	LPG 2
Micra I 1.2	K10	1.2	40	4	01.86-	.93	MA12	1,1	BPR5ES-11	4424		LPG 2
Micra I 1.3 Super S	K10	1.3	55	4	.93-		CG13DE	1,1	BKR5E-11	6953	33	LPG 1

MICRA II

Micra 1.0	K11E	1.0	40	4	08.92-09.00		CG10DE	1,1	BKR4E-11	5424		
Micra 1.0	K11E	1.0	40	4	08.92-09.00		CG10DE	1,1	BKR6E-11	2756	14	LPG 1
Micra II 1.0	K11	1.0	40	4	.93-	.00	CG10DE Cat.	1,1	BKR5E-11	6953	33	LPG 1
Micra 1.0	K11E	1.0	44	4	09.00-02.03		CG10DE	1,1	BKR4E-11	5424		
Micra 1.0	K11E	1.0	44	4	09.00-02.03		CG10DE	1,1	BKR6E-11	2756	14	LPG 1
Micra II 1.0	K11	1.0	44	4	.00-	.02	CG10DE	1,1	BKR5E-11	6953	33	LPG 1
Micra 1.3	K11E	1.3	55	4	08.92-09.00		CG13DE	1,1	BKR4E-11	5424		
Micra 1.3	K11E	1.3	55	4	08.92-09.00		CG13DE	1,1	BKR6E-11	2756	14	LPG 1
Micra II 1.3	K11	1.3	55	4	.93-	.00	CG13DE Cat.	1,1	BKR5E-11	6953	33	LPG 1
Micra II 1.4	K11	1.4	60	4	.00-	.02	CGA3DE	1,1	BKR5E-11	6953	33	LPG 1

MICRA III

Micra III 1.0	K12	1.0	48	4	01.03-05.05		CG10DE	1,1	LFR5E-11	1669		LPG 7
Micra 1.0	K12E	1.0	48	4	01.03-05.05		CG10DE	1,1	LFR4AP-11	5613		
Micra 1.0	K12E	1.0	48	4	01.03-05.05		CG10DE	1,1	LFR5AP-11	4775		
Micra 1.2	K12E	1.2	48	4	01.03-06.10		CG12DE, CR12DE	1,1	LFR4AP-11	5613		
Micra 1.2	K12E	1.2	48	4	01.03-06.10		CG12DE, CR12DE	1,1	LFR5AP-11	4775		
Micra III 1.2	K12	1.2	48	4	02.03-		CR12DE	1,1	LFR5E-11	1669		LPG 7
Micra 1.2 LPG	K12E	1.2	59	4	10.02-06.10		CG12DELPG, CR12DE	1,1	LFR4AP-11	5613		
Micra 1.2 LPG	K12E	1.2	59	4	10.02-06.10		CG12DELPG, CR12DE	1,1	LFR5AP-11	4775		
Micra 1.2	K12E	1.2	59	4	01.03-06.10		CG12DE, CR12DE	1,1	LFR4AP-11	5613		
Micra 1.2	K12E	1.2	59	4	01.03-06.10		CG12DE, CR12DE	1,1	LFR5AP-11	4775		
Micra III 1.2	K12	1.2	59	4	02.03-		CR12DE	1,1	LFR5E-11	1669		LPG 7
Micra 1.4	K12E	1.4	65	4	01.03-06.10		CR14DE	1,1	LFR4AP-11	5613		
Micra 1.4	K12E	1.4	65	4	01.03-06.10		CR14DE	1,1	LFR5AP-11	4775		
Micra III 1.4	K12	1.4	65	4	02.03-		CR14DE	1,1	LFR5E-11	1669		LPG 7
Micra CC 1.4	CK12E	1.4	65	4	06.05-01.09		CR14DE	1,1	LFR4AP-11	5613		
Micra CC 1.4	CK12E	1.4	65	4	06.05-01.09		CR14DE	1,1	LFR5AP-11	4775		
Micra III 1.6 SR	K12	1.6	81	4	07.05-		HR16DE	1,1	PLZKAR6A-11	5118	51	

MICRA IV

Micra 1.2	K13K	1.2	56	3	05.10-09.15		HR12DE	1,1	LZKAR6AP-11	6643		
Micra IV 1.2	K13	1.2	59	3	05.10-		HR12DE	1,1	LZKAR6AP-11	6643		
Micra 1.2 LPG	K13K	1.2	59	3	07.10-09.15		HR12DE	1,1	LZKAR6AP-11	6643		
Micra 1.2 DIG-S Supercharged	K13K, K13KK	1.2	72	3	03.11-		HR12DDR, HR12DR	1,1	DILKAR7E11HS	97439		
Micra IV 1.2 DIG (OE 22401-1HC1B)	K13	1.2	72	3	04.11-		HR12DDR	1,1	LZKAR6AP-11	6643		





e kW C
Y
I



Stock-N°

VLINE

LPG/CNG

NISSAN

MICRA V

Micra 0.9 LPG	K14FR	0.9	64	3	03.19-	HR09DET	0,7	ILKAR7F7G	90061		
Micra 0.9 iG-T	K14FR	0.9	66	3	12.16-	HR09DET	0,7	ILKAR7F7G	90061		

MURANO

Murano 2.5 Hybrid Supercharged	Z52R	2.5	172	4	01.16-	QR25DER	0,9	DILKAR7C9H	91215		
Murano 2.5		2.5		4	09.04-	QR25DE	1,1	LFR5A-11	6376		LPG 7
Murano 3.5 Z50	Z50	3.5	172	6	12.02-	VQ35DE	1,1	PLFR5A-11	6240		LPG 7
Murano 3.5 CVTC	Z51, Z51R	3.5	183	6	01.10-09.14	VQ35DE	1,1	DF7H-11B	1317		
Murano 3.5	Z52R	3.5	183	6	01.16-	VQ35DE	1,1	DF7H-11B	1317		
Murano 3.5 CVTC	Z51	3.5	191	6	09.08-09.14	VQ35DE	1,1	DF7H-11B	1317		
Murano 3.5 CVTC	Z51	3.5	195	6	11.07-09.14	VQ35DE	1,1	DF7H-11B	1317		

MURANO II

Murano II 3.5 Z51	Z51	3.5	188	6	10.08-	VQ35DE	1,1	DF7H-11B	1317		
Murano II 3.5 Z51	Z51	3.5	191	6	01.10-	VQ35DE	1,1	DF7H-11B	1317		
Murano II 3.5 Z51	Z51	3.5	195	6	11.07-	VQ35DE	1,1	DF7H-11B	1317		

NOTE

Note 1.2 LPG	E12E	1.2	59	3	06.13-	HR12DE	1,1	LZKAR6AP-11	6643		
Note 1.4 LPG	E11E	1.4	65	4	01.06-08.13	CR14DE	1,1	LFR4AP-11	5613		
Note 1.4	E11E	1.4	65	4	01.06-08.13	CR14DE	1,1	LFR4AP-11	5613		
Note 1.4 LPG	E11E	1.4	65	4	01.06-08.13	CR14DE	1,1	LFR5AP-11	4775		
Note 1.4	E11E	1.4	65	4	01.06-08.13	CR14DE	1,1	LFR5AP-11	4775		

NOTE I

Note I 1.4	E11	1.4	65	4	03.06-08.13	CR14DE	1,1	LFR5E-11	1669		LPG 7
Note I 1.6	E11	1.6	81	4	03.06-08.13	HR16DE	1,1	PLZKAR6A-11	5118	51	
Note I 1.6	E11	1.6	85	4	03.06-08.13	HR16DE	1,1	PLZKAR6A-11	5118	51	

NOTE II

Note II 1.2	E12	1.2	59	3	06.13-	HR12DE	1,1	LZKAR6AP-11	6643		
Note 1.2 DIG-S Supercharged	E12E	1.2	65	3	12.13-	HR12DR	1,1	DILKAR7E11HS	97439		
Note II 1.2 DIG-S (OE 22401-1HC1B)	E12	1.2	72	3	06.13-	HR12DDR	1,1	LZKAR6AP-11	6643		
Note 1.2 DIG-S Supercharged	E12E	1.2	72	3	12.13-	HR12DR	1,1	DILKAR7E11HS	97439		

NV200

NV200 1.6 16V	M20M	1.6	81	4	02.10-	HR16DE	1,1	PLZKAR6A-11	5118	51	
---------------	------	-----	----	---	--------	--------	-----	-------------	------	----	--

PATHFINDER D21

Pathfinder D21		3.0		6	.92-	VG30E	0,9	BKR6EY	3696		LPG 1
----------------	--	-----	--	---	------	-------	-----	--------	------	--	-------

PATHFINDER R50

Pathfinder R50		3.3	110	6	.92-12.00	VG33E V6	1,1	BKR5E-11	6953	33	LPG 1
Pathfinder 3.3	R50	3.3	110	6	12.95-10.00	VG33E	1,1	BKR5ES-11	2382		LPG 1
Pathfinder 3.3	R50	3.3	110	6	12.95-10.00	VG33E	1,1	BKR6ES-11	5553		LPG 1
Pathfinder R50		3.3	110	6	.97- .00	VG33E V6	1,1	BKR5ES-11	2382	33	LPG 1
Pathfinder 3.3	R50	3.3	125	6	12.95-07.05	VG33E	1,1	BKR5ES-11	2382		LPG 1
Pathfinder 3.3	R50	3.3	125	6	12.95-07.05	VG33E	1,1	BKR6ES-11	5553		LPG 1
Pathfinder R50		3.5	162	6	01.00-	VQ35E V6	1,1	PLFR5A-11	6240		LPG 7

PATHFINDER R51M

Pathfinder 4.0	R51M	4.0	198	6	01.05-08.14	VQ40DE	1,1	PLFR5A-11	6240		LPG 7
Pathfinder 4.0	R51M	4.0	198	6	01.05-08.14	VQ40DE	1,1	PLFR6A-11	7654		LPG 7
Pathfinder R51M		4.0	198	6	09.05-	VQ40DE	1,1	LFR5AIX-11	4469		LPG 7





kw C
Y
I



Stock-N°

VLINE

LPG/CNG

NISSAN

PATHFINDER R52R

Pathfinder 2.5 Hybrid Supercharged	R52R, R52RR	2.5	172	4	08.14-	QR25DER	0,9	DILKAR7C9H	91215		
Pathfinder 3.5 CVTC	R52R, R52RR	3.5	183	6	08.14-	VQ35DE	1,1	DF7H-11B	1317		

PATROL

Patrol Y60 & 260		2.0		4	04.89-	RB30S	0,9	BKR6E	6962	28	LPG 1
Patrol Y60		4.2		6	.88-12.95	TB42S	0,7	BP6ES	7811	4	LPG 2
Patrol Y60		4.2		6	.93- .94	RB42S	0,9	BPR5E	7281	6	LPG 2
Patrol Y60		4.2		6	.93-	TB42E	0,9	BPR5E	7281	6	LPG 2
Patrol		4.2		6	- .92	TB42S	0,8	BP5ES	6511	8	LPG 2
Patrol		4.5		6	.98-	TB45E	1,1	BPR5E-11	5638		LPG 2

PATROL III

Patrol III 5.6	Y62	5.6	298	8	04.10-	VK56VD	1,1	DILKAR7B11	1406		
----------------	-----	-----	-----	---	--------	--------	-----	------------	------	--	--

PATROL V

Patrol GR 4.8	Y61	4.8	180	6	03.00-03.10	TB48DE	1,1	PLFR5A-11	6240		LPG 7
Patrol GR 4.8	Y61	4.8	180	6	03.00-	TB48DE	1,1	PLFR5A-11	6240		LPG 7
Patrol GR 4.8	Y61	4.8	180	6	03.00-03.10	TB48DE	1,1	PLFR6A-11	7654		LPG 7
Patrol GR 4.8	Y61	4.8	180	6	03.00-	TB48DE	1,1	PLFR6A-11	7654		LPG 7

PICK UP

Pick Up B120		1.2		4	.93-	A12	0,8	BP5ES	6511	8	LPG 2
Pick Up D21		1.6		4	09.85-	Z16	0,8	BPR6ES	7822	2	LPG 2
Pick Up D21		2.0		4	09.85-04.92	Z20	0,8	BPR6ES	7822	2	LPG 2
Pick Up D21		2.0		4	04.92-	Z20S	0,8	BPR6ES	7822	2	LPG 2
Pick Up 720		2.2	71	4	03.86-04.93	Z22	0,7	BP6ES	7811	4	LPG 2
Pick Up D21		2.4	74	4	09.85-04.92	Z24	0,8	BPR6ES	7822	2	LPG 2
Pick Up D21		2.4	76	4	10.88-04.92	Z24i	0,8	BPR6ES	7822	2	LPG 2
Pick Up (King Cab) 2.4	D22	2.4	88	4	02.98-10.01	KA24E	1,1	ZFR6E-11	6430		
Pick Up D22		2.4	88	4	.98- .01	KA24E	1,1	ZFR5E-11	4435		
Pick Up MD21		2.4	93	4	.94- .98	KA24E	1,1	ZFR5E-11	4435		
Pick Up (King Cab) 2.4	D22	2.4	98	4	11.01-04.05	KA24DE	1,1	BKR5E-11	6953	33	LPG 1
Pick Up (King Cab) 2.4	D22	2.4	98	4	11.01-04.05	KA24DE	1,1	BKR6E-11	2756	14	LPG 1
Pick Up (King Cab) 2.4	D22	2.4	98	4	11.01-04.05	KA24DE	1,1	BKR7E-11	1283		
Pick Up D22		2.4	98	4	.02-	KA24E	1,1	BKR6E-11	2756	14	LPG 1
Pick Up (D22) 2.4	D22	2.4	110	4	08.99-11.09	KA24DE	1,1	BKR5E-11	6953	33	LPG 1
Pick Up (D22) 2.4	D22	2.4	110	4	08.99-11.09	KA24DE	1,1	BKR6E-11	2756	14	LPG 1
Pick Up (D22) 2.4	D22	2.4	110	4	08.99-11.09	KA24DE	1,1	BKR7E-11	1283		
Pick Up (King Cab) 2.4	D22	2.4	110	4	11.01-04.05	KA24DE	1,1	BKR5E-11	6953	33	LPG 1
Pick Up (King Cab) 2.4	D22	2.4	110	4	11.01-04.05	KA24DE	1,1	BKR6E-11	2756	14	LPG 1
Pick Up (King Cab) 2.4	D22	2.4	110	4	11.01-04.05	KA24DE	1,1	BKR7E-11	1283		
Pick Up		3.0		6	.90-	VG30I	1,1	BCPR5ES-11	3524		LPG 3
Pick Up		3.0		6	.93-	VG30E	0,9	BKR6EY	3696		LPG 1

PIXO

Pixo	UA0	1.0	50	3	06.09-	K10B	1,1	IKR6G11	7980		
------	-----	-----	----	---	--------	------	-----	---------	------	--	--

PRAIRIE 4 X EX + 4 X IN M11

Prairie (Twin Spark) 4 x EX + 4 x IN	M11	2.0	72	4	10.88- .92	CA20E Cat.	1,1	BCPR5ES-11 + BCPR6ES-11	3524 + 7121		LPG 3 x 8 pcs
Prairie (Twin Spark) 4 x EX + 4 x IN	M11	2.0	73	4	10.88- .92	CA20E	1,1	BCPR5ES-11 + BCPR6ES-11	3524 + 7121		LPG 3 x 8 pcs





l kW C
Y I



Stock-N°

VLINE

LPG/CNG

NISSAN

PRAIRIE 4 X EX + 4 X IN M11

Prairie (Twin Spark) 4 x EX + 4 x IN	M11	2.0	98	4	.93- .95	CA20E	1,1	BCPR5ES-11 + BCPR6ES-11	3524 + 7121		LPG 3 x 8 pcs
--------------------------------------	-----	-----	----	---	----------	-------	-----	----------------------------	----------------	--	------------------

PRAIRIE M11

Prairie M11		2.0	98	4	.93- .95	CA20S	0,7	BCP6ES	4930	17	LPG 3
Prairie M11		2.0		4	.90- .92	CA20S	0,8	BCPR6ES	2330	12	LPG 3
Prairie M11		2.4	98		.94- .95	KA24E	1,1	ZFR5E-11	4435		
Prairie M11		3.0	98	4	.92- .95	KA24E	1,1	ZFR5E-11	4435		

PRIMASTAR

Primastar J4		2.0	88	4	.03-	F4R	0,9	BKR6EZ	4619	38	LPG 1
--------------	--	-----	----	---	------	-----	-----	--------	------	----	-------

PRIMERA P10

Primera P10	P10	1.6	66	4	.93- .96	GA16DE	0,8	BKR5E	7938	35	LPG 1
Primera P10	P10	1.6	66	4	.93-	GA16DS	0,9	BKR6EY	3696		LPG 1
Primera P10	P10	2.0	85	4	.93- .96	SR20DE	0,9	BKR5EY	7390		LPG 1

PRIMERA P10E

Primera P10E	P10E	1.6	66	4	06.90- .93	GA16DS Cat.	0,9	BKR6E	6962	28	LPG 1
Primera 1.6	P10E	1.6	66	4	06.90-01.96	GA16DS	0,8	BKR5E	7938	35	LPG 1
Primera 1.6	P10E	1.6	66	4	06.90-01.96	GA16DS	0,9	BKR7E	6097		BKR8EIX
Primera P10E	P10E	1.6	70	4	06.90- .92	GA16DS	0,9	BKR6E	6962	28	LPG 1
Primera 1.6	P10E	1.6	71	4	06.90-01.96	GA16DS	0,8	BKR5E	7938	35	LPG 1
Primera 1.6	P10E	1.6	71	4	06.90-06.93	GA16DS	0,8	BKR5E	7938	35	LPG 1
Primera 1.6	P10E	1.6	71	4	06.90-01.96	GA16DS	0,9	BKR7E	6097		BKR8EIX
Primera 1.6	P10E	1.6	71	4	06.90-06.93	GA16DS	0,9	BKR7E	6097		BKR8EIX
Primera 1.6	P10E	1.6	75	4	06.93-01.96	GA16DE	0,8	BKR5E	7938	35	LPG 1
Primera 1.6	P10E	1.6	75	4	06.93-01.96	GA16DE	0,9	BKR6E	6962	28	LPG 1
Primera 1.6	P10E	1.6	75	4	06.93-01.96	GA16DE	0,9	BKR7E	6097		BKR8EIX
Primera P10E	P10E	2.0	85	4	06.90- .96	SR20Di	0,9	BKR5EY	7390		LPG 1
Primera 2.0	P10E	2.0	85	4	06.90-01.96	SR20Di	0,9	BKR6EY	3696		LPG 1
Primera 2.0	P10E	2.0	85	4	04.91-06.96	SR20Di	0,9	BKR6EY	3696		LPG 1
Primera P10E	P10E	2.0	89	4	06.90- .96	SR20Di SPI	0,9	BKR5EY	7390		LPG 1
Primera P10E	P10E	2.0	110	4	06.90- .96	SR20DE EGI Cat.	0,9	BKR6EY	3696		LPG 1

PRIMERA P11

Primera P11	P11	1.6	66	4	.96-	GA16DE	0,9	BKR6E	6962	28	LPG 1
Primera 16V P11	P11	1.6	74	4	09.96- .00	GA16DE	0,8	BKR5E	7938	35	LPG 1
Primera P11	P11	1.6	78	4	02.00-07.02	QG16DE	1,1	BKR5E-11	6953	33	LPG 1
Primera P11	P11	1.8	83	4	02.00- .02	QG18DE	1,1	BKR5E-11	6953	33	LPG 1
Primera 16V P11	P11	2.0	85	4	09.96- .99	SR20DE	1,1	BKR5EY-11	2355		LPG 1
Primera P11	P11	2.0	91	4	.96- .99	SR20DE	0,9	BKR5EY	7390		LPG 1
Primera 16V P11	P11	2.0	96	4	09.96- .99	SR20DE	1,1	BKR5EY-11	2355		LPG 1
Primera P11	P11	2.0	103	4	.00- .02	SR20DE	1,1	PFR6G-11	5555		PFR7G
Primera P11	P11	2.0	109	4	.96- .99	SR20DE	0,9	BKR5EY	7390		LPG 1
Primera P11	P11	2.0	110	4	06.97- .99	SR20DE	0,9	BKR6EY	3696		LPG 1

PRIMERA P11E

Primera 1.6	P11E	1.6	66	4	09.96-07.02	GA16DE	0,9	BKR6E	6962	28	LPG 1
Primera 1.6	P11E	1.6	66	4	09.96-12.01	GA16DE	0,9	BKR6E	6962	28	LPG 1
Primera 1.6	P11E	1.6	66	4	09.96-07.02	GA16DE	0,9	BKR7E	6097		BKR8EIX
Primera 1.6	P11E	1.6	66	4	09.96-12.01	GA16DE	0,9	BKR7E	6097		BKR8EIX





l kW C
Y
I



Stock-N°

VLINE

LPG/CNG

NISSAN

PRIMERA P11E

Primera 1.6	P11E	1.6	73	4	09.96-07.02	GA16DE	0,9	BKR6E	6962	28	LPG 1
Primera 1.6	P11E	1.6	73	4	09.96-10.00	GA16DE	0,9	BKR6E	6962	28	LPG 1
Primera 1.6	P11E	1.6	73	4	09.96-07.02	GA16DE	0,9	BKR7E	6097		BKR8EIX
Primera 1.6	P11E	1.6	73	4	09.96-10.00	GA16DE	0,9	BKR7E	6097		BKR8EIX
Primera 1.6	P11E	1.6	78	4	06.96-12.01	QG16DE	1,1	BKR4E-11	5424		
Primera 1.6	P11E	1.6	78	4	06.96-12.01	QG16DE	1,1	BKR6E-11	2756	14	LPG 1
Primera 1.6 LPG	P11E	1.6	78	4	09.00-07.02	QG16DE	1,1	BKR4E-11	5424		
Primera 1.6	P11E	1.6	78	4	09.00-07.02	QG16DE	1,1	BKR4E-11	5424		
Primera 1.6 LPG	P11E	1.6	78	4	09.00-07.02	QG16DE	1,1	BKR5E-11	6953	33	LPG 1
Primera 1.6 LPG	P11E	1.6	78	4	09.00-07.02	QG16DE	1,1	BKR6E-11	2756	14	LPG 1
Primera 1.6	P11E	1.6	78	4	09.00-07.02	QG16DE	1,1	BKR6E-11	2756	14	LPG 1
Primera 1.8	P11E	1.8	84	4	08.99-07.02	QG18DE	1,1	BKR4E-11	5424		
Primera 1.8	P11E	1.8	84	4	08.99-12.01	QG18DE	1,1	BKR4E-11	5424		
Primera 1.8	P11E	1.8	84	4	08.99-07.02	QG18DE	1,1	BKR6E-11	2756	14	LPG 1
Primera 1.8	P11E	1.8	84	4	08.99-12.01	QG18DE	1,1	BKR6E-11	2756	14	LPG 1
Primera 2.0	P11E	2.0	96	4	06.96-12.01	SR20DE	1,1	PFR5G-11	2647		
Primera 2.0	P11E	2.0	96	4	06.96-12.01	SR20DE	1,1	PFR6G-11	5555		PFR7G
Primera 2.0 (For cold climate zones)	P11E	2.0	96	4	06.96-12.01	SR20DE	1,1	PFR7G-11	2380		
Primera 2.0	P11E	2.0	96	4	09.96-07.02	SR20DE	1,1	PFR5G-11	2647		
Primera 2.0	P11E	2.0	96	4	09.96-07.02	SR20DE	1,1	PFR6G-11	5555		PFR7G
Primera 2.0 (For cold climate zones)	P11E	2.0	96	4	09.96-07.02	SR20DE	1,1	PFR7G-11	2380		
Primera 2.0	P11E	2.0	103	4	08.99-07.02	SR20DE	1,1	PFR5G-11	2647		
Primera 2.0	P11E	2.0	103	4	08.99-12.01	SR20DE	1,1	PFR5G-11	2647		
Primera 2.0 (For cold climate zones)	P11E	2.0	103	4	08.99-07.02	SR20DE	1,1	PFR7G-11	2380		
Primera 2.0 (For cold climate zones)	P11E	2.0	103	4	08.99-12.01	SR20DE	1,1	PFR7G-11	2380		
Primera 2.0	P11E	2.0	105	4	06.96-01.02	SR20DE	1,1	PFR5G-11	2647		
Primera 2.0	P11E	2.0	105	4	06.96-01.02	SR20DE	1,1	PFR6G-11	5555		PFR7G
Primera 2.0 (For cold climate zones)	P11E	2.0	105	4	06.96-01.02	SR20DE	1,1	PFR7G-11	2380		

PRIMERA P12

Primera P12	P12	1.6	78	4	01.02-	QG16DE	1,1	LFR5A-11	6376		LPG 7
Primera P12	P12	1.8	85	4	03.02-	QG18DE	1,1	LFR5A-11	6376		LPG 7
Primera Traveller P12	P12	1.8	85	4	03.02-	QG18DE	1,1	LFR5A-11	6376		LPG 7
Primera P12	P12	2.0	103	4	03.02-	QR20DE	1,1	LFR5A-11	6376		LPG 7

PRIMERA P12E

Primera 1.6	P12E	1.6	80	4	01.02-04.06	QG16DE	1,1	LFR5A-11	6376		LPG 7
Primera 1.6	P12E	1.6	80	4	07.02-04.06	QG16DE	1,1	LFR5A-11	6376		LPG 7
Primera 1.8 LPG	P12E	1.8	85	4	03.02-10.08	QG18DE	1,1	LFR5A-11	6376		LPG 7
Primera 2.0	P12E	2.0	103	4	03.02-10.08	QR20DE	1,1	PLFR5A-11	6240		LPG 7
Primera Estate/Wagon 2.0	P12E	2.0	103	4	03.02-06.08	QR20DE	1,1	PLFR5A-11	6240		LPG 7
Primera 2.0	P12E	2.0	103	4	03.02-10.08	QR20DE	1,1	PLFR6A-11	7654		LPG 7
Primera Estate/Wagon 2.0	P12E	2.0	103	4	03.02-06.08	QR20DE	1,1	PLFR6A-11	7654		LPG 7
Primera 2.0	P12E	2.0	103	4	07.02-10.08	QR20DE	1,1	PLFR5A-11	6240		LPG 7
Primera 2.0	P12E	2.0	103	4	07.02-10.08	QR20DE	1,1	PLFR6A-11	7654		LPG 7

PRIMERA W10

Primera Estate/Wagon 1.6	W10	1.6	66	4	07.90-03.98	GA16DE, GA16DS	0,8	BKR5E	7938	35	LPG 1
--------------------------	-----	-----	----	---	-------------	----------------	-----	-------	------	----	-------





l kW C
Y
I



Stock-N°

VLINE

LPG/CNG

NISSAN

PRIMERA W10

Primera Estate/Wagon 1.6	W10	1.6	66	4	07.90-03.98	GA16DE, GA16DS	0,9	BKR7E	6097		BKR8EIX
Primera Estate/Wagon 1.6	W10	1.6	75	4	02.91-03.98	GA16DE	0,8	BKR5E	7938	35	LPG 1
Primera Estate/Wagon 1.6	W10	1.6	75	4	02.91-03.98	GA16DE	0,9	BKR6E	6962	28	LPG 1
Primera Estate/Wagon 1.6	W10	1.6	75	4	02.91-03.98	GA16DE	0,9	BKR7E	6097		BKR8EIX
Primera Estate/Wagon 2.0	W10	2.0	85	4	07.90-03.98	SR20Di	0,9	BKR6EY	3696		LPG 1
Primera Estate/Wagon 2.0	W10	2.0	110	4	07.94-04.96	SR20DE	0,9	BKR5EY	7390		LPG 1
Primera Estate/Wagon 2.0	W10	2.0	110	4	07.94-04.96	SR20DE	0,9	BKR6EY	3696		LPG 1
Primera Estate/Wagon 2.0	W10	2.0	110	4	05.96-01.98	SR20DE	1,1	BKR6EY-11	4368		LPG 1

PRIMERA WP11E

Primera Estate/Wagon 1.6	WP11E	1.6	66	4	04.98-12.01	GA16DE	0,9	BKR6E	6962	28	LPG 1
Primera Estate/Wagon 1.6	WP11E	1.6	66	4	04.98-12.01	GA16DE	0,9	BKR7E	6097		BKR8EIX
Primera Estate/Wagon 1.6	WP11E	1.6	73	4	04.98-12.01	GA16DE	0,9	BKR6E	6962	28	LPG 1
Primera Estate/Wagon 1.6	WP11E	1.6	73	4	04.98-12.01	GA16DE	0,9	BKR7E	6097		BKR8EIX
Primera Estate/Wagon 1.8 LPG	WP11E	1.8	84	4	08.99-12.01	QG18DE	1,1	BKR4E-11	5424		
Primera Estate/Wagon 1.8	WP11E	1.8	84	4	08.99-12.01	QG18DE	1,1	BKR4E-11	5424		
Primera Estate/Wagon 1.8 LPG	WP11E	1.8	84	4	08.99-12.01	QG18DE	1,1	BKR5E-11	6953	33	LPG 1
Primera Estate/Wagon 1.8 LPG	WP11E	1.8	84	4	08.99-12.01	QG18DE	1,1	BKR6E-11	2756	14	LPG 1
Primera Estate/Wagon 1.8	WP11E	1.8	84	4	08.99-12.01	QG18DE	1,1	BKR6E-11	2756	14	LPG 1
Primera Estate/Wagon 2.0	WP11E	2.0	85	4	06.96-12.01	SR20DE	1,1	PFR5G-11	2647		
Primera Estate/Wagon 2.0	WP11E	2.0	85	4	06.96-12.01	SR20DE	1,1	PFR6G-11	5555		PFR7G
Primera Estate/Wagon 2.0 (For cold climate zones)	WP11E	2.0	85	4	06.96-12.01	SR20DE	1,1	PFR7G-11	2380		
Primera Estate/Wagon 2.0	WP11E	2.0	96	4	04.98-12.01	SR20DE	1,1	PFR5G-11	2647		
Primera Estate/Wagon 2.0	WP11E	2.0	96	4	04.98-12.01	SR20DE	1,1	PFR6G-11	5555		PFR7G
Primera Estate/Wagon 2.0 (For cold climate zones)	WP11E	2.0	96	4	04.98-12.01	SR20DE	1,1	PFR7G-11	2380		
Primera Estate/Wagon 2.0	WP11E	2.0	103	4	08.99-12.01	SR20DE	1,1	PFR5G-11	2647		
Primera Estate/Wagon 2.0 (For cold climate zones)	WP11E	2.0	103	4	08.99-12.01	SR20DE	1,1	PFR7G-11	2380		

PULSAR

Pulsar 1.6 DIG-T	C13M	1.6	140	4	01.15-	MR16DDT	0,9	DILKAR7E9HS	95003		
------------------	------	-----	-----	---	--------	---------	-----	-------------	-------	--	--

PULSAR N17

Pulsar 1.2 DIG-T	C13M	1.2	85	4	07.14-	HRA2DDT	0,7	ILKAR7F7G	90061		
------------------	------	-----	----	---	--------	---------	-----	-----------	-------	--	--

QASHQAI

Qashqai 1.6 LPG	J10E	1.6	86	4	01.11-04.14	HR16DE	1,1	DILZKAR6A11	91691		
Qashqai 1.6 LPG	J10E	1.6	86	4	01.11-04.14	HR16DE	1,1	PLZKAR6A-11	5118	51	
Qashqai+2 2.0	JJ10E	2.0	103	4	01.10-04.14	MR20DE	1,1	PLZKAR6A-11	5118	51	

QASHQAI I

Qashqai I 1.6	J10E, JJ10E	1.6	84	4	02.07-01.14	HR16DE	1,1	PLZKAR6A-11	5118	51	
Qashqai I 1.6	J10E, JJ10E	1.6	86	4	11.10-01.14	HR16DE	1,1	PLZKAR6A-11	5118	51	
Qashqai I 2.0	J10E, JJ10E	2.0	104	4	02.07-01.14	MR20DE	1,1	PLZKAR6A-11	5118	51	

QASHQAI II

Qashqai II 1.6 DIG-T	J11E	1.6	120	4	02.14-	MR16DDT	0,9	DILKAR7E9HS	95003		
Qashqai II 2.0	J11E, J11R	2.0	106	4	12.13-	MR20DD	1,1	DILKAR7D11H	90565		

SERENA

Serena 1.6	C23M	1.6	71	4	02.93-09.01	GA16DE	0,9	BKR6E	6962	28	LPG 1
Serena 1.6	C23M	1.6	71	4	02.93-09.01	GA16DE	0,9	BKR7E	6097		BKR8EIX





kw
C
Y
I



Stock-N°

VLINE

LPG/CNG

NISSAN

SERENA

Serena C23	1.6	71	4	07.93-	GA16DE Cat.	0,8	BKR5E	7938	35	LPG 1
Serena C23	2.0	93	4	01.92-	SR20DE Cat.	0,9	BKR5EY	7390		LPG 1
Serena 2.0 C23M	2.0	93	4	07.92-09.01	SR20DE	0,9	BKR6EY	3696		LPG 1
Serena C25/NC25	2.0		4	05.05-	MR20DE	1,1	LZKAR6AP-11	6643		

SILVIA RS12

Silvia RS12 4x EX + 4 x IN	1.8	90	4	.89- .95	CA18E	1,1	BCPR5ES-11 + BCPR6ES-11	3524 + 7121		LPG 3 x 8 pcs
----------------------------	-----	----	---	----------	-------	-----	----------------------------	----------------	--	------------------

SILVIA TURBO S12

Silvia Turbo S12	1.8	90	4	10.83-	CA18ET Cat.	1,1	BCPR6ES-11	7121	11	LPG 3
------------------	-----	----	---	--------	-------------	-----	------------	------	----	-------

SKYLINE

Skyline V6 24V V35	2.5	158	6	.02-	VQ25DD	1,1	LFR5AIX-11	4469		LPG 7
Skyline	2.6		6	.98-	RB26DETT	1,1	PFR7A-11	4579		
Skyline V6 24V HV35	3.0	191	6	.02-	VQ30DD	1,1	LFR5AIX-11	4469		LPG 7
Skyline V6 24V V35	3.5	200	6	.02-	VQ35DE	1,1	LFR5AIX-11	4469		LPG 7

SUNNY B12

Sunny 1.3 B12	1.3	44	4	01.86-	E13S	0,9	BPR5ES	7422	6	LPG 2
Sunny 1.4 B12	1.4		4	10.88-	GA14S	0,8	BCPR6ES	2330	12	LPG 3

SUNNY B13

Sunny 1.0 B13	1.0		4	.93- .95	E10S Cat.	0,8	BP5ES	6511	8	LPG 2
Sunny 1.3 B13	1.3		4	.93- .95	GA13DS	0,9	BKR6E	6962	28	LPG 1
Sunny 1.4 B13	1.4	55	4	.93- .95	GA14DS	0,9	BKR6E	6962	28	LPG 1
Sunny 1.6 B13	1.6		4	- .96	GA16DE	0,9	BKR6E	6962	28	LPG 1
Sunny 1.6 B13	1.6		4	- .95	GA16DS	0,9	BKR6E	6962	28	LPG 1
Sunny 2.0 B13	2.0		4	.91- .96	SR20DE	0,9	BKR6EY	3696		LPG 1

SUNNY B14

Sunny 1.3 B14	1.3		4	.95-	GA13DS	0,9	BKR6E	6962	28	LPG 1
Sunny 1.3 B14	1.3		4	.95-	GA13DE	1,1	BKR6E-11	2756	14	LPG 1
Sunny 1.4 B14	1.4		4	.95-	GA14DE	0,9	BKR6E	6962	28	LPG 1
Sunny 1.6 B14	1.6		4	.95-	GA16DE	1,1	BKR6E-11	2756	14	LPG 1
Sunny 1.8 B14	1.8		4	.95-	GA18DE(B)	0,9	BKR6E	6962	28	LPG 1
Sunny 1.8 B14	1.8		4	.95-	GA18DE(A)	1,1	BKR6E-11	2756	14	LPG 1
Sunny 2.0 B14	2.0		4	.95-	SR20DE	0,9	BKR6EY	3696		LPG 1

SUNNY GTI B12

Sunny GTI 1.8 B12	1.8	92	4	10.89- .91	CA18DE	1,1	PFR6A-11	4045		
-------------------	-----	----	---	------------	--------	-----	----------	------	--	--

SUNNY GTI N13

Sunny GTI 1.8 N13	1.8	92	4	10.89- .91	CA18DE	1,1	PFR6A-11	4045		
-------------------	-----	----	---	------------	--------	-----	----------	------	--	--

SUNNY GTI N14

Sunny GTI 2.0 N14	2.0	105	4	10.90-05.95	SR20DE Cat.	0,9	BKR6EY	3696		LPG 1
-------------------	-----	-----	---	-------------	-------------	-----	--------	------	--	-------

SUNNY GTI-R N14

Sunny GTI-R 2.0 N14	2.0	162	4	10.93- .95	SR20DET Cat.	0,9	PFR7B-9	4180		
---------------------	-----	-----	---	------------	--------------	-----	---------	------	--	--

SUNNY N13

Sunny 1.0 N13	1.0		4	10.88- .91	E10S	0,9	BPR5ES	7422	6	LPG 2
Sunny 1.4 N13	1.4	55	4	10.88- .91	GA14S	0,7	BCP6ES	4930	17	LPG 3
Sunny 1.6 N13	1.6	54	4	06.86- .91	E16i Cat.	1,1	BPR5ES-11	4424		LPG 2
Sunny 1.6 N13	1.6	62	4	06.86- .91	E16i	1,1	BPR5ES-11	4424		LPG 2
Sunny 1.6 N13	1.6	66	4	10.88- .91	GA16i Cat.	1,1	BCP6ES-11	7210		LPG 3





l kW C
Y
I



Stock-N°

VLINE

LPG/CNG

NISSAN

SUNNY N13

Sunny 1.6	N13	1.6		4	10.88- .91	GA16S	0,8	BCPR6ES	2330	12	LPG 3
-----------	-----	-----	--	---	------------	-------	-----	---------	------	----	-------

SUNNY N14

Sunny 1.4	N14	1.4	55	4	10.90- .93	GA14DS	0,8	BKR5E	7938	35	LPG 1
Sunny 1.4	N14	1.4	55	4	10.90-05.95	GA14DS	0,8	BKR5E	7938	35	LPG 1
Sunny 1.4	N14	1.4	55	4	10.90-06.95	GA14DS	0,8	BKR5E	7938	35	LPG 1
Sunny 1.4	N14	1.4	55	4	10.90-05.95	GA14DS	0,9	BKR7E	6097		BKR8EIX
Sunny 1.4	N14	1.4	55	4	10.90-06.95	GA14DS	0,9	BKR7E	6097		BKR8EIX
Sunny 1.4	N14	1.4	55	4	10.92- .95	GA14DE	0,8	BKR5E	7938	35	LPG 1
Sunny 1.4	N14	1.4	60	4	10.90-06.95	GA14DE	0,8	BKR5E	7938	35	LPG 1
Sunny 1.4	N14	1.4	60	4	10.90-06.95	GA14DE	0,9	BKR6E	6962	28	LPG 1
Sunny 1.4	N14	1.4	60	4	10.90-06.95	GA14DE	0,9	BKR7E	6097		BKR8EIX
Sunny 1.4	N14	1.4	64	4	10.90-06.95	GA14DE	0,8	BKR5E	7938	35	LPG 1
Sunny 1.4	N14	1.4	64	4	10.90-06.95	GA14DE	0,9	BKR7E	6097		BKR8EIX
Sunny 1.6	N14	1.6	66	4	10.90- .93	GA16DS	0,9	BKR6E	6962	28	LPG 1
Sunny 1.6	N14	1.6	66	4	10.90-05.95	GA16DS	0,8	BKR5E	7938	35	LPG 1
Sunny 1.6	N14	1.6	66	4	10.90-05.95	GA16DS	0,9	BKR7E	6097		BKR8EIX
Sunny 1.6	N14	1.6	66	4	10.92- .95	GA16DE	0,8	BKR5E	7938	35	LPG 1
Sunny 1.6	N14	1.6	75	4	10.92- .95	GA16DE	0,8	BKR5E	7938	35	LPG 1
Sunny 1.6	N14	1.6	75	4	10.92-06.95	GA16DE	0,8	BKR5E	7938	35	LPG 1
Sunny 1.6	N14	1.6	75	4	10.92-05.95	GA16DE	0,9	BKR6E	6962	28	LPG 1
Sunny 1.6	N14	1.6	75	4	10.92-06.95	GA16DE	0,9	BKR6E	6962	28	LPG 1
Sunny 1.6	N14	1.6	75	4	10.92-05.95	GA16DE	0,9	BKR7E	6097		BKR8EIX
Sunny 1.6	N14	1.6	75	4	10.92-06.95	GA16DE	0,9	BKR7E	6097		BKR8EIX
Sunny 2.0 -/GTi	N14	2.0	105	4	10.90-10.95	SR20DE	0,9	BKR5EY	7390		LPG 1
Sunny 2.0 -/GTi	N14	2.0	105	4	10.90-10.95	SR20DE	0,9	BKR7EY	2270		
Sunny 2.0 GTi-R	N14	2.0	162	4	11.92-06.95	SR20DET	0,9	PFR6B-9	3100		PFR7B
Sunny 2.0	N14	2.0		4	.95-	SR20DET	0,6	PFR7B	4853		

SUNNY Y10

Sunny Van 1.6	Y10	1.6	66	4	10.92-03.00	GA16DS	0,9	BKR6E	6962	28	LPG 1
Sunny Van 1.6	Y10	1.6	66	4	10.92-03.00	GA16DS	0,9	BKR7E	6097		BKR8EIX
Sunny 1.6	Y10	1.6	66	4	.94- .00	GA16DS	0,9	BKR6E	6962	28	LPG 1
Sunny 1.6	Y10	1.6	67	4	.94- .00	SR16DE	0,8	BKR5E	7938	35	LPG 1
Sunny Estate/Wagon 1.6	Y10	1.6	75	4	10.92-03.00	GA16DE	0,8	BKR5E	7938	35	LPG 1
Sunny Estate/Wagon 1.6	Y10	1.6	75	4	10.92-03.00	GA16DE	0,9	BKR7E	6097		BKR8EIX
Sunny Van 1.6	Y10	1.6	75	4	11.92-04.96	GA16DE	0,8	BKR5E	7938	35	LPG 1
Sunny Van 1.6	Y10	1.6	75	4	11.92-04.96	GA16DE	0,9	BKR6E	6962	28	LPG 1
Sunny Van 1.6	Y10	1.6	75	4	11.92-04.96	GA16DE	0,9	BKR7E	6097		BKR8EIX
Sunny Estate/Wagon 1.6	Y10	1.6	75	4	04.94-03.00	GA16DE	0,8	BKR5E	7938	35	LPG 1
Sunny Estate/Wagon 1.6	Y10	1.6	75	4	04.94-03.00	GA16DE	0,9	BKR6E	6962	28	LPG 1
Sunny Estate/Wagon 1.6	Y10	1.6	75	4	04.94-03.00	GA16DE	0,9	BKR7E	6097		BKR8EIX
Sunny 2.0	Y10	2.0	105	4	.93- .00	GA20DE	0,9	BKR6EY	3696		LPG 1

SUNNY Y10L

Sunny 1.6	Y10L	1.6	66	4	10.90- .93	GA16DS	0,9	BKR6E	6962	28	LPG 1
Sunny 1.6	Y10L	1.6	66	4	10.92- .00	GA16DE	0,8	BKR5E	7938	35	LPG 1





e kW C
Y
I



Stock-Nº

VLINE

LPG/CNG

NISSAN

TEANA

Sunny 3.5	J32	3.5	185	6	07.08-	VQ35DE	1,1	DF7H-11B	1317		
-----------	-----	-----	-----	---	--------	--------	-----	----------	------	--	--

TEANA II

Teana 3.5 CVTC	J32, J32R	3.5	183	6	07.08-12.15	VQ35DE	1,1	DF7H-11B	1317		
----------------	-----------	-----	-----	---	-------------	--------	-----	----------	------	--	--

TERRANO 1

Terrano 1 (Twin Spark) 4 x EX + 4 x IN		2.4	76	4	08.86- .92	Z24i	0,9	BPR5ES	7422	6	LPG 2
Terrano 1 WD21		2.4	76	4	08.87-07.92	Z24i Cat.	0,9	BPR5ES	7422	6	LPG 2
Terrano 1 WD/WHYD21		3.0	109	6	01.90-07.96	VG30E Cat.	0,9	BKR6EY	3696		LPG 1

TERRANO 2

Terrano 2 R20		2.4	86	6	05.96- .01	KA24E	1,1	ZFR5E-11	4435		
Terrano 2 R20		2.4	87	6	05.96- .01	KA24E	1,1	ZFR5E-11	4435		
Terrano 2 R20		2.4	91	6	07.93- .96	KA24E	1,1	ZFR5E-11	4435		

TERRANO II

Terrano II 2.4	R20	2.4	85	4	05.96-01.02	KA24E	1,1	ZFR6E-11	6430		
Terrano II 2.4	R20	2.4	87	4	05.96-02.02	KA24E	1,1	ZFR6E-11	6430		
Terrano II 2.4	R20	2.4	87	4	05.96-11.05	KA24E	1,1	ZFR6E-11	6430		
Terrano II 2.4	R20	2.4	91	4	02.93-12.97	KA24E	1,1	ZFR6E-11	6430		
Terrano II 2.4	R20	2.4	91	4	07.96-12.97	KA24E	1,1	ZFR6E-11	6430		

TIIDA

Tiida 1.6		1.6	81	4	01.08-	HR16DE	1,1	PLZKAR6A-11	5118	51	
Tiida 1.8	SC11X	1.8	78	4	01.07-06.11	MR18DE	1,1	PLZKAR6A-11	5118	51	
Tiida 1.8	C11X	1.8	93	4	05.04-06.13	MR18DE	1,1	PLZKAR6A-11	5118	51	
Tiida 1.8	SC11X	1.8	93	4	09.07-06.13	MR18DE	1,1	PLZKAR6A-11	5118	51	
Tiida 1.8		1.8	93	4	01.08-	MR18DE	1,1	PLZKAR6A-11	5118	51	

TINO 1.8 16V

Tino 1.8 16V V10		1.8	88	4	.99-	NEOQG18DE	1,1	BKR5E-11	6953	33	LPG 1
------------------	--	-----	----	---	------	-----------	-----	----------	------	----	-------

TINO 2.0 16V

Tino 2.0 16V V10		2.0	99	4	.99-	SR20DE	1,1	PFR6G-11	5555		PFR7G
------------------	--	-----	----	---	------	--------	-----	----------	------	--	-------

URVAN E24

Urvan E24		2.0	64	4	11.86- .97	Z20 OHC	0,9	BPR5ES	7422	6	LPG 2
Urvan E24		2.0		4	.95- .97	NA20S	1,1	BPR6ES-11	4824	13	LPG 2
Urvan E24		2.4	74	4	02.87- .97	Z24S OHC	0,9	BPR5ES	7422	6	LPG 2
Urvan E24		2.4	74	4	05.89- .96	Z24i	0,9	BPR5ES	7422	6	LPG 2
Urvan E24		2.4		4	.95- .97	Z24	0,7	BP6ES	7811	4	LPG 2

VANETTE

Vanette Cargo 1.6	C23M	1.6	71	4	09.94-05.01	GA16DE	0,9	BKR6E	6962	28	LPG 1
Vanette Cargo 1.6	C23M	1.6	71	4	09.94-05.01	GA16DE	0,9	BKR7E	6097		BKR8EIX
Vanette Cargo 1.6	C23M	1.6	72	4	01.96-05.01	GA16DE	0,9	BKR6E	6962	28	LPG 1
Vanette Cargo 1.6	C23M	1.6	72	4	01.96-05.01	GA16DE	0,9	BKR7E	6097		BKR8EIX
Vanette Cargo 1.6	C23M	1.6	75	4	09.94-05.01	GA16DE	0,8	BKR5E	7938	35	LPG 1
Vanette Cargo 1.6	C23M	1.6	75	4	09.94-05.01	GA16DE	0,9	BKR6E	6962	28	LPG 1
Vanette E 1.6	C23M	1.6	75	4	09.94-05.01	GA16DE	0,9	BKR6E	6962	28	LPG 1
Vanette Cargo 1.6	C23M	1.6	75	4	09.94-05.01	GA16DE	0,9	BKR7E	6097		BKR8EIX
Vanette E 1.6	C23M	1.6	75	4	09.94-05.01	GA16DE	0,9	BKR7E	6097		BKR8EIX
Vanette M20		1.6		4	.09-	HR16DE	1,1	LZKAR6AP-11	6643		
Vanette		2.0		4	.93-	SR20E	0,9	BKR5EY	7390		LPG 1





e kW C Y I



Stock-N°

VLINE

LPG/CNG

NISSAN**VANETTE C22**

Vanette C22	2.4	74	4	09.86-	.93	Z24i.	0,9	BPR5ES	7422	6	LPG 2
-------------	-----	----	---	--------	-----	-------	-----	--------	------	---	-------

VANETTE CARGO (NL)

Vanette Cargo (NL)	1.6	71	4	03.95-			0,8	BKR5E	7938	35	LPG 1
--------------------	-----	----	---	--------	--	--	-----	-------	------	----	-------

VANETTE E (NL)

Vanette E (NL)	1.6	71	4	03.95-			0,8	BKR5E	7938	35	LPG 1
----------------	-----	----	---	--------	--	--	-----	-------	------	----	-------

VANETTE GC22

Vanette GC22	1.5	51	4	09.86-	.95	A15S	0,9	BPR5ES	7422	6	LPG 2
--------------	-----	----	---	--------	-----	------	-----	--------	------	---	-------

Vanette GC22	2.0	64	4	09.86-	.95	Z20S	0,8	BPR6ES	7822	2	LPG 2
--------------	-----	----	---	--------	-----	------	-----	--------	------	---	-------

X-TRAIL

X-Trail 1.6 DIG-T	T32	1.6	120	4	06.15-	MR16DDT	0,9	DILKAR7E9HS	95003		
-------------------	------------	-----	-----	---	--------	---------	-----	-------------	-------	--	--

X-Trail 2.0	T30	2.0	103	4	06.01-	QR20DE	1,1	LFR5A-11	6376		LPG 7
-------------	------------	-----	-----	---	--------	--------	-----	----------	------	--	-------

X-Trail 2.0	T30	2.0	103	4	07.01-12.08	QR20DE	1,1	PLFR5A-11	6240		LPG 7
-------------	------------	-----	-----	---	-------------	--------	-----	-----------	------	--	-------

X-Trail 2.0	T30	2.0	103	4	07.01-12.08	QR20DE	1,1	PLFR6A-11	7654		LPG 7
-------------	------------	-----	-----	---	-------------	--------	-----	-----------	------	--	-------

X-Trail 2.0	T30	2.0	103	4	09.01-05.07	QR20DE	1,1	PLFR5A-11	6240		LPG 7
-------------	------------	-----	-----	---	-------------	--------	-----	-----------	------	--	-------

X-Trail 2.0	T30	2.0	103	4	09.01-05.07	QR20DE	1,1	PLFR6A-11	7654		LPG 7
-------------	------------	-----	-----	---	-------------	--------	-----	-----------	------	--	-------

X-Trail 2.0	T31	2.0	103	4	06.08-12.13	MR20DE	1,1	PLZKAR6A-11	5118	51	
-------------	------------	-----	-----	---	-------------	--------	-----	-------------	------	----	--

X-Trail 2.0	T31	2.0	104	4	06.07-	MR20DE	1,1	PLZKAR6A-11	5118	51	
-------------	------------	-----	-----	---	--------	--------	-----	-------------	------	----	--

X-Trail 2.0	T32, T32R, T32RR	2.0	106	4	02.14-	MR20DD	1,1	DILKAR7D11H	90565		
-------------	-------------------------	-----	-----	---	--------	--------	-----	-------------	-------	--	--

X-Trail 2.0	T30	2.0	110	4	09.01-05.07	QR20DE	1,1	LFR5A-11	6376		LPG 7
-------------	------------	-----	-----	---	-------------	--------	-----	----------	------	--	-------

X-Trail 2.0	T30	2.0	110	4	09.01-05.07	QR20DE	1,1	PLFR5A-11	6240		LPG 7
-------------	------------	-----	-----	---	-------------	--------	-----	-----------	------	--	-------

X-Trail 2.0	T30	2.0	110	4	09.01-05.07	QR20DE	1,1	PLFR6A-11	7654		LPG 7
-------------	------------	-----	-----	---	-------------	--------	-----	-----------	------	--	-------

X-Trail T30	T30	2.0		4	02.01-	SR20VET	0,9	PLFR6A-9	4342		LPG 7
-------------	------------	-----	--	---	--------	---------	-----	----------	------	--	-------

X-Trail 2.5	T30	2.5	121	4	09.01-02.07	QR25DE	1,1	LFR5A-11	6376		LPG 7
-------------	------------	-----	-----	---	-------------	--------	-----	----------	------	--	-------

X-Trail 2.5	T30	2.5	121	4	09.01-05.07	QR25DE	1,1	PLFR5A-11	6240		LPG 7
-------------	------------	-----	-----	---	-------------	--------	-----	-----------	------	--	-------

X-Trail 2.5	T30	2.5	121	4	09.01-05.07	QR25DE	1,1	PLFR6A-11	7654		LPG 7
-------------	------------	-----	-----	---	-------------	--------	-----	-----------	------	--	-------

X-Trail 2.5	T31	2.5	124	4	06.07-	QR25DE	1,1	DILKAR6A11	9029		
-------------	------------	-----	-----	---	--------	--------	-----	------------	------	--	--

X-Trail 2.5	T30	2.5	132	4	11.02-02.07	QR25DE	1,1	LFR5A-11	6376		LPG 7
-------------	------------	-----	-----	---	-------------	--------	-----	----------	------	--	-------

X-Trail 2.5	T30	2.5	132	4	11.02-12.08	QR25DE	1,1	PLFR5A-11	6240		LPG 7
-------------	------------	-----	-----	---	-------------	--------	-----	-----------	------	--	-------

X-Trail 2.5	T30	2.5	132	4	11.02-12.08	QR25DE	1,1	PLFR6A-11	7654		LPG 7
-------------	------------	-----	-----	---	-------------	--------	-----	-----------	------	--	-------

X-Trail 2.5	T30	2.5	134	4	09.01-02.07	QR25DE	1,1	LFR5A-11	6376		LPG 7
-------------	------------	-----	-----	---	-------------	--------	-----	----------	------	--	-------

X-Trail 2.5	T30	2.5	134	4	09.01-02.07	QR25DE	1,1	PLFR5A-11	6240		LPG 7
-------------	------------	-----	-----	---	-------------	--------	-----	-----------	------	--	-------

X-Trail 2.5	T30	2.5	134	4	09.01-02.07	QR25DE	1,1	PLFR6A-11	7654		LPG 7
-------------	------------	-----	-----	---	-------------	--------	-----	-----------	------	--	-------

OPEL**ADAM**

Adam 1.0 ECOTEC	P08	1.0	66	3	07.14-	B10XFL	0,7	ILNAR8B7G	91970		
-----------------	------------	-----	----	---	--------	--------	-----	-----------	-------	--	--

Adam 1.0 ECOTEC	P08	1.0	85	3	07.14-	B10XFT	0,7	ILNAR8B7G	91970		
-----------------	------------	-----	----	---	--------	--------	-----	-----------	-------	--	--

Adam 1.2	P08	1.2	51	4	10.12-	A12XEL	0,9	ZFR6V-G	8894		
----------	------------	-----	----	---	--------	--------	-----	---------	------	--	--

Adam 1.4	P08	1.4	64	4	10.12-	A14XEL	0,9	ZFR6V-G	8894		
----------	------------	-----	----	---	--------	--------	-----	---------	------	--	--

Adam 1.4	P08	1.4	74	4	10.12-	A14XER	0,9	ZFR6V-G	8894		
----------	------------	-----	----	---	--------	--------	-----	---------	------	--	--

Adam 1.4 ECOTEC	P08	1.4	110	4	11.14-01.19	B14NEH, D14NEH	0,7	IFR7X7G	91039		
-----------------	------------	-----	-----	---	-------------	----------------	-----	---------	-------	--	--

AGILA

Agila 1.0 12V		1.0	43	3	07.00-07.04	Z10XE	0,8	BKR5EK	7956	23	LPG 1
---------------	--	-----	----	---	-------------	-------	-----	--------	------	----	-------

Agila 1.0 12V		1.0	44	3	08.03-03.08	Z10XEP	0,8	ZFR5F	5165	53	LPG 6
---------------	--	-----	----	---	-------------	--------	-----	-------	------	----	-------

Agila 1.0	F68	1.0	48	3	05.08-	K10B	1,1	IKR6G11	7980		
-----------	------------	-----	----	---	--------	------	-----	---------	------	--	--





l kW C
Y
I



Stock-N^o

VLINE

LPG/CNG

OPEL

AGILA

Agila 1.2 16V		1.2	55	4	07.00-07.04	Z12XE	0,8	BKR5EK	7956	23	LPG 1
Agila 1.2 16V		1.2	59	4	07.04-04.08	Z12XEP	0,8	ZFR5F	5165	53	LPG 6
Agila 1.2	F68	1.2	63	4	05.08-	K12B	1,1	IKR6G11	7980		
Agila 1.2	F68	1.2	69	4	06.10-	K12B	1,1	IKR6G11	7980		

ANTARA

Antara 2.4 ECOTEC	L07	2.4	103	4	09.06-12.11	Z24XE	0,8	BKR5EK	7956	23	LPG 1
Antara 3.0 VVT	L07	3.0	190	6	11.10-12.12	A30XF, A30XH	1,1	ILTR6E11	90117		
Antara 3.2		3.2	167	6	03.07-12.11	Z32SEE	1,3	PTR5A-13	2467	25	LPG 4

ASTRA F

Astra F 1.4	51, 52	1.4	44	4	09.91-02.98	X14NZ OHC I	0,8	BKR5EK	7956	23	LPG 1
Astra F 1.4	51, 52	1.4	44	4	09.91-07.95	C14NZ OHC	0,9	BPR5ES	7422	6	LPG 2
Astra F 1.4	51, 52	1.4	44	4	08.95-02.98	C14NZ OHC	0,8	BKR5EK	7956	23	LPG 1
Astra F 1.4	51, 52	1.4	55	4	09.91-03.93	14NV OHC I	0,8	BKR5EK	7956	23	LPG 1
Astra F 1.4 Si		1.4	60	4	09.91-07.95	C14SE OHC	0,9	BPR5ES	7422	6	LPG 2
Astra F 1.4 Si		1.4	60	4	03.93-07.95	14SE OHC	0,9	BPR5ES	7422	6	LPG 2
Astra F 1.4 Si		1.4	60	4	08.95-02.98	14SE OHC, C14SE OHC	0,8	BKR5EK	7956	23	LPG 1
Astra F 1.4	F08	1.4	66	4	02.96-02.98	X14XE DOHC	0,8	BKR5EK	7956	23	LPG 1
Astra F 1.6		1.6	52	4	03.93-12.94	X16SZ OHC	0,9	BPR5ES	7422	6	LPG 2
Astra F 1.6		1.6	52	4	01.95-02.96	X16SZ OHC	0,8	BKR5EK	7956	23	LPG 1
Astra F 1.6		1.6	55	4	09.91-07.95	C16NZ OHC	0,9	BPR5ES	7422	6	LPG 2
Astra F 1.6		1.6	55	4	08.94-02.98	16LZ2 OHC	0,8	BKR5EK	7956	23	LPG 1
Astra F 1.6		1.6	55	4	08.95-02.96	C16NZ OHC	0,8	BKR5EK	7956	23	LPG 1
Astra F 1.6		1.6	55	4	02.96-08.00	X16SZR OHC	0,8	BKR5EK	7956	23	LPG 1
Astra F 1.6		1.6	55	4	09.97-	16NZR OHC	0,8	BKR5EK	7956	23	LPG 1
Astra F 1.6 Si		1.6	74	4	02.92-07.95	C16SE OHC I	0,9	BPR5ES	7422	6	LPG 2
Astra F 1.6 16V		1.6	74	4	08.94-02.98	X16XEL DOHC	0,8	BKR5EK	7956	23	LPG 1
Astra F 1.6 16V		1.6	74	4	08.95-02.98	C16SE OHC I	0,8	BKR5EK	7956	23	LPG 1
Astra F 1.8		1.8	66	4	09.91-07.95	C18NZ OHC II	0,9	BPR5ES	7422	6	LPG 2
Astra F 1.8		1.8	66	4	08.95-02.98	C18NZ OHC II	0,8	BKR5EK	7956	23	LPG 1
Astra F 1.8 16V		1.8	85	4	02.94-03.96	C18XEL DOHC	0,8	BKR5EK	7956	23	LPG 1
Astra F 1.8 16V		1.8	85	4	02.96-02.98	X18XE DOHC	0,8	BKR5EK	7956	23	LPG 1
Astra F 1.8 16V		1.8	92	4	05.93-04.94	C18XE DOHC II	0,8	BKR5EK	7956	23	LPG 1
Astra F 2.0		2.0	85	4	09.91-07.95	C20NE OHC II	0,9	BPR5ES	7422	6	LPG 2
Astra F 2.0		2.0	85	4	08.95-02.98	C20NE OHC II	0,8	BKR5EK	7956	23	LPG 1
Astra F 2.0 16V		2.0	100	4	02.95-02.98	X20XEV DOHC	0,8	BKR5EK	7956	23	LPG 1
Astra F 2.0 GSI 16V		2.0	110	4	09.91-08.92	C20XE DOHC, C20XE-LN DOHC I	0,9	BKR6EK	2288	20	LPG 1
Astra F 2.0 GSI 16V		2.0	110	4	09.92-02.98	C20XE DOHC, C20XE-LN DOHC I	0,8	BKR5EK	7956	23	LPG 1

ASTRA G

Astra G 1.2 16V		1.2	48	4	03.98-09.00	X12XE DOHC	0,8	BKR5EK	7956	23	LPG 1
Astra G 1.2 16V		1.2	55	4	08.00-01.05	Z12XE	0,8	BKR5EK	7956	23	LPG 1
Astra G 1.4 16V		1.4	66	4	03.98-01.05	X14XE DOHC	0,8	BKR5EK	7956	23	LPG 1
Astra G 1.4		1.4	66	4	08.00-08.03	Z14XE DOHC	0,8	BKR5EK	7956	23	LPG 1
Astra G 1.4		1.4	66	4	08.03-01.05	Z14XE DOHC	0,8	ZFR5F	5165	53	LPG 6
Astra G 1.6 16V		1.6	55	4	03.98-09.00	X16SZR	0,8	BKR5EK	7956	23	LPG 1





l kW C
Y I



Stock-N°

VLINE

LPG/CNG

OPEL

ASTRA G

Astra G 1.6	1.6	62	4	08.00-01.05	Z16SE	0,8	BKR5EK	7956	23	LPG 1
Astra G 1.6 16V	1.6	74	4	03.98-01.05	X16XEL	0,8	BKR5EK	7956	23	LPG 1
Astra G 1.6 16V	1.6	74	4	08.00-01.05	Z16XE	0,8	BKR5EK	7956	23	LPG 1
Astra G 1.6 16V	1.6	74	4	03.03-01.05	Z16XEP	0,8	ZFR5F	5165	53	LPG 6
Astra G 1.8 16V	1.8	85	4	03.98-09.00	X18XE1	0,8	BKR5EK	7956	23	LPG 1
Astra G 1.8 16V	1.8	85	4	08.00-	Z18XEL	0,6	BKR5EQUPA	3566		
Astra G 1.8 16V	1.8	92	4	08.00-04.04	Z18XE	0,8	BKR5EK	7956	23	LPG 1
Astra G 1.8 16V	1.8	92	4	05.04-05.05	Z18XE	0,8	ZFR5F	5165	53	LPG 6
Astra G 2.0 16V	2.0	100	4	03.98-01.05	X20XEV	0,8	BKR5EK	7956	23	LPG 1
Astra G 2.0 16V	2.0	118	4	10.99-09.02	X20XER DOHC	0,8	BKR5EK	7956	23	LPG 1
Astra G 2.0 16V Turbo	2.0	140	4	09.00-01.05	Z20LET	0,8	BKR5EK	7956	23	LPG 1
Astra G 2.0 GTC Turbo	2.0	147	4	11.02-05.05	Z20LER	0,8	ZFR5F	5165	53	LPG 6
Astra G 2.2 16V	2.2	108	4	01.99-	X22XE DOHC	0,8	BKR5EK	7956	23	LPG 1
Astra G 2.2 16V	2.2	108	4	09.00-01.05	Z22SE	1,0	LTR6B-10T	5948		

ASTRA H

Astra H 1.4	1.4	55	4	03.04-12.11	Z14XEL	0,8	ZFR5F	5165	53	LPG 6
Astra H 1.4 ECOTEC	1.4	66	4	03.04-	Z14XEP	0,8	ZFR5F	5165	53	LPG 6
Astra H 1.6	1.6	74	4	03.04-12.12	Z16XEP	0,8	ZFR5F	5165	53	LPG 6
Astra H 1.6 ECOTEC/VVT/VVT ECOTEC	1.6	85	4	01.07-	Z16XER	0,8	ZFR5F	5165	53	LPG 6
Astra H 1.6 ECOTEC	1.6	132	4	10.06-12.11	Z16LET	0,9	ZFR6BP-G	1748		LPG6
Astra H 1.8	1.8	92	4	03.04-06.10	Z18XE	0,8	ZFR5F	5165	53	LPG 6
Astra H 1.8 VVT ECOTEC	1.8	103	4	04.06-06.10	Z18XER	0,8	ZFR5F	5165	53	LPG 6
Astra H 2.0 OPC/VXR	2.0	125	4	03.04-12.09	Z20LEL	0,8	ZFR5F	5165	53	LPG 6
Astra H 2.0 GTC Turbo	2.0	147	4	03.05-12.12	Z20LER	0,8	ZFR5F	5165	53	LPG 6
Astra H 2.0 OPC/VXR	2.0	177	4	09.05-09.11	Z20LEH	0,8	PFR6T-G	6314		

ASTRA J

Astra J 1.4 ECOTEC	1.4	64	4	10.09-10.15	A14XEL	0,9	ZFR6V-G	8894		
Astra J 1.4 ECOTEC for (OE No. 55565219)	1.4	74	4	12.09-10.15	A14XER, B14XER	0,9	ZFR6V-G	8894		
Astra J 1.4 ECOTEC (For OE-No. 25197812)	35, 68, 69	1.4	74	4	12.09-10.15	A14XER, B14XER	0,7	IZFR5R7G	94123	
Astra J 1.4 ECOTEC	1.4	88	4	07.10-10.15	A14NEL	0,7	IFR7X7G	91039		
Astra 1.4 ECOTEC	69	1.4	88	4	06.12-10.15	A14NEL, B14NEL	0,7	IFR7X7G	91039	
Astra J 1.4 ECOTEC	1.4	103	4	10.09-10.15	A14NET	0,7	IFR7X7G	91039		
Astra 1.4 LPG ECOTEC	69	1.4	103	4	07.14-	A14NET	0,7	IFR7X7G	91039	
Astra J 1.6 ECOTEC / VVT ECOTEC	1.6	85	4	10.09-10.15	A16XER	0,9	ZFR6V-G	8894		
Astra J 1.6 SIDI/SIDI ECOTEC	35	1.6	125	4	12.12-10.15	A16XHT, B16SHL	0,7	ILNAR8B7G	91970	
Astra J 1.6 SIDI/SIDI ECOTEC	68	1.6	125	4	12.12-10.15	A16XHT, B16SHL	0,7	ILNAR8B7G	91970	
Astra J 1.6 SIDI/SIDI ECOTEC	69	1.6	125	4	12.12-10.15	A16XHT	0,7	ILNAR8B7G	91970	
Astra J GTC 1.6 SIDI ECOTEC	08	1.6	125	4	12.12-10.15	A16XHT, B16SHL	0,7	ILNAR8B7G	91970	
Astra J 1.6 ECOTEC	1.6	132	4	10.09-10.15	A16LET	0,9	ZFR6BP-G	1748		LPG6
Astra J GTC 1.6 SIDI ECOTEC	08	1.6	147	4	07.13-10.15	A16SHT, B16SHT	0,7	ILNAR8B7G	91970	
Astra J 1.8 ECOTEC / VVT ECOTEC	1.8	103	4	10.11-	A18XER	0,9	ZFR6V-G	8894		
Astra GTC 2.0 OPC ECOTEC	08	2.0	206	4	04.12-	A20NFT, B20NFT	0,9	ILTR5D	5476	

ASTRA K

Astra 1.0 ECOTEC	35, 68	1.0	66	3	06.18-	D10XFL	0,7	ILNAR8B7G	91970	
------------------	--------	-----	----	---	--------	--------	-----	-----------	-------	--





l kW C
Y
I



Stock-N°

VLINE

LPG/CNG

OPEL

ASTRA K

Astra K 1.0 ECOTEC	35, 68	1.0	77	3	06.15-	B10XFL	0,7	ILNAR8B7G	91970		
Astra 1.2	35, 68	1.2	81	3	08.19-	F12SHL	0,7	ILNAR8B7G	91970		
Astra 1.2	35, 68	1.2	96	3	08.19-	F12SHT	0,7	ILNAR8B7G	91970		
Astra 1.2	35, 68	1.2	107	3	08.19-	F12SHR	0,7	ILNAR8B7G	91970		
Astra K 1.4 ECOTEC	35, 68	1.4	74	4	06.15-	B14XE	0,9	SILZNA6D9	94051		
Astra K 1.4 ECOTEC	35, 68	1.4	92	4	06.15-	B14XFL	0,7	ILNAR8B7G	91970		
Astra K 1.4 ECOTEC	35, 68	1.4	110	4	06.15-	B14XFT	0,7	ILNAR8B7G	91970		
Astra K 1.6 ECOTEC	35	1.6	147	4	11.15-	B16SHT	0,7	ILNAR8B7G	91970		
Astra K 1.6 ECOTEC	68	1.6	147	4	11.15-	B16SHT	0,7	ILNAR8B7G	91970		

CALIBRA

Calibra 2.0		2.0	85	4	06.90-07.95	C20NE OHC II	0,9	BPR5ES	7422	6	LPG 2
Calibra 2.0		2.0	85	4	08.95-08.97	C20NE OHC II	0,8	BKR5EK	7956	23	LPG 1
Calibra 2.0 16V		2.0	100	4	11.93-08.97	X20XEV DOHC	0,8	BKR5EK	7956	23	LPG 1
Calibra 2.0 16V		2.0	110	4	02.90-08.92	C20XE	0,9	BKR6EK	2288	20	LPG 1
Calibra 2.0 16V		2.0	110	4	06.90-04.97	C20XE-LN DOHC	0,9	BKR6EK	2288	20	LPG 1
Calibra 2.0 16V		2.0	110	4	09.92-02.94	C20XE	0,8	BKR5EK	7956	23	LPG 1
Calibra 2.0 Turbo 4x4		2.0	150	4	03.92-08.97	C20LET DOHC	1,1	ZFR6F-11	4291		LPG 6
Calibra 2.5 V6		2.5	125	6	09.93-08.97	C25XE DOHC, X25XE DOHC	0,8	BKR5EK	7956	23	LPG 1

CAMPO

Campo 2.3		2.3	66	4	11.88-09.91	4ZD1	0,8	BPR6ES	7822	2	LPG 2
Campo 2.3		2.3	72	4	10.91-09.96	4ZD1	0,8	BPR6ES	7822	2	LPG 2

CASCADA

Cascada 1.4 ECOTEC		1.4	88	4	03.13-	A14NEL	0,7	IFR7X7G	91039		
Cascada 1.4 ECOTEC		1.4	103	4	03.13-	A14NET	0,7	IFR7X7G	91039		
Cascada 1.6 SIDI ECOTEC	67	1.6	100	4	05.18-04.19	D16SHJ	0,7	ILNAR8B7G	91970		
Cascada 1.6 ECOTEC/SIDI ECOTEC	67	1.6	125	4	04.13-	A16XHT, B16SHL	0,7	ILNAR8B7G	91970		
Cascada 1.6 ECOTEC/SIDI ECOTEC	67	1.6	147	4	11.13-	A16SHT, B16SHT	0,7	ILNAR8B7G	91970		

COMBO

Combo 1.4		1.4	44	4	03.93-10.01	C14NZ OHC	0,8	BKR5EK	7956	23	LPG 1
Combo 1.4		1.4	44	4	02.96-10.01	X14SZ OHC	0,8	BKR5EK	7956	23	LPG 1
Combo 1.4		1.4	60	4	03.93-10.01	C14SE OHC	0,8	BKR5EK	7956	23	LPG 1
Combo 1.4		1.4	66	4	10.04-	Z14XEP	0,8	ZFR5F	5165	53	LPG 6
Combo 1.6		1.6	64	4	10.01-	Z16SE	0,8	BKR5EK	7956	23	LPG 1

COMBO D

Combo 1.4	B05, C06, C26, D26, E26	1.4	70	4	02.12-	A14FP	1,0	DCPR7E-N-10	4983	43	
-----------	-------------------------	-----	----	---	--------	-------	-----	-------------	------	----	--

CORSA

Corso Van 1.2 ECOTEC	05	1.2	51	4	01.15-	B12XEL	0,7	IZFR5R7G	94123		
Corso 1.4 ECOTEC	08, 68	1.4	55	4	09.14-	B14XEJ	0,7	IZFR5R7G	94123		
Corso 1.4 LPG ECOTEC	08, 68	1.4	66	4	03.15-	B14XEL	0,7	IZFR5R7G	94123		

CORSA A

Corso A 1.0		1.0	33	4	09.82-09.92	10S OHV	0,7	BPR6HS	7022	3	BPR7HIX
Corso A 1.2		1.2	33	4	02.90-03.93	12NV OHC I	0,8	BPR6ES	7822	2	LPG 2
Corso A 1.2		1.2	33	4	09.90-03.93	C12NZ OHC I	0,9	BPR5ES	7422	6	LPG 2
Corso A 1.2		1.2	37	4	09.86-03.93	A12ST OHC	0,8	BPR6ES	7822	2	LPG 2





l kW C
Y
I



Stock-N°

VLINE

LPG/CNG

OPEL

CORSA A

Corsa A 1.3 (Irmischer)	1.3	61	4	04.85-03.93	13E irmischer	0,8	BPR6ES	7822	2	LPG 2
Corsa A 1.4	1.4	44	4	10.89-03.93	C14NZ OHC	0,9	BPR5ES	7422	6	LPG 2
Corsa A 1.4	1.4	53	4	10.89-09.92	14NV OHC I	0,8	BPR6ES	7822	2	LPG 2
Corsa A 1.4	1.4	60	4	09.91-03.93	C14SE OHC	0,9	BPR5ES	7422	6	LPG 2
Corsa A 1.6	1.6	55	4	03.88-09.91	C16NZ	0,9	BPR5ES	7422	6	LPG 2
Corsa A 1.6 Irmischer	1.6	72	4	06.90-03.92	C16SEL irmischer	0,8	BPR6ES	7822	2	LPG 2
Corsa A 1.6	1.6	74	4	03.88-03.92	E16SE OHC I	0,8	BPR6ES	7822	2	LPG 2
Corsa A 1.6	1.6	74	4	02.92-03.93	C16SE DOHC	0,9	BPR5ES	7422	6	LPG 2

CORSA B

Corsa B 1.0 12V	1.0	40	3	03.97-08.00	X10XE DOHC	0,8	BKR5EK	7956	23	LPG 1
Corsa B 1.2	1.2	33	4	03.93-07.95	12NZ, C12NZ OHC I, X12SZ OHC	0,9	BPR5ES	7422	6	LPG 2
Corsa B 1.2	1.2	33	4	08.95-12.97	12NZ	0,8	BKR5EK	7956	23	LPG 1
Corsa B 1.2	1.2	33	4	08.95-09.00	C12NZ OHC I, X12SZ OHC	0,8	BKR5EK	7956	23	LPG 1
Corsa B 1.2 16V	1.2	48	4	09.97-08.01	X12XE	0,8	BKR5EK	7956	23	LPG 1
Corsa B 1.4	1.4	44	4	03.93-07.95	C14NZ OHC	0,9	BPR5ES	7422	6	LPG 2
Corsa B 1.4	1.4	44	4	08.95-08.98	C14NZ OHC	0,8	BKR5EK	7956	23	LPG 1
Corsa B 1.4	1.4	44	4	03.96-07.00	X14SZ	0,8	BKR5EK	7956	23	LPG 1
Corsa B 1.4	1.4	60	4	03.93-07.95	C14SE OHC	0,9	BPR5ES	7422	6	LPG 2
Corsa B 1.4	1.4	60	4	08.95-07.97	C14SE OHC	0,8	BKR5EK	7956	23	LPG 1
Corsa B 1.4	1.4	63	4	06.98-10.00	C14SEL OHC	0,8	BKR5EK	7956	23	LPG 1
Corsa B 1.4 16V	1.4	66	4	11.94-08.00	X14XE DOHC	0,8	BKR5EK	7956	23	LPG 1
Corsa B 1.6	1.6	74	4	06.98-10.00	C16SEL DOHC	0,8	BKR5EK	7956	23	LPG 1
Corsa B 1.4 16V	1.6	78	4	08.94-08.01	X16XE DOHC	0,8	BKR5EK	7956	23	LPG 1
Corsa B 1.6	1.6	80	4	03.93-08.94	C16XE DOHC I	0,8	BKR5EK	7956	23	LPG 1

CORSA C

Corsa C 1.0 12V	1.0	43	3	08.00-06.03	Z10XE	0,8	BKR5EK	7956	23	LPG 1
Corsa C 1.0 ECOTEC	1.0	44	3	06.03-12.09	Z10XEP	0,8	ZFR5F	5165	53	LPG 6
Corsa C 1.2	1.2	55	4	08.00-06.04	Z12XE	0,8	BKR5EK	7956	23	LPG 1
Corsa C 1.2	1.2	59	4	07.04-06.06	Z12XEP	0,8	ZFR5F	5165	53	LPG 6
Corsa C 1.4	1.4	66	4	08.00-10.06	Z14XE	0,8	BKR5EK	7956	23	LPG 1
Corsa C 1.4	1.4	66	4	06.03-06.06	Z14XEP	0,8	ZFR5F	5165	53	LPG 6
Corsa C 1.6	1.6	62	4	08.00-04.05	Z16SE	0,8	BKR5EK	7956	23	LPG 1
Corsa C 1.8	1.8	92	4	08.00-07.06	Z18XE	0,8	BKR5EK	7956	23	LPG 1

CORSA D

Corsa D 1.0 ECOTEC	1.0	44	3	07.06-08.14	Z10XEP	0,8	ZFR5F	5165	53	LPG 6	
Corsa D 1.0 ECOTEC	1.0	48	3	01.10-08.14	A10XEP	0,9	ZFR6V-G	8894			
Corsa D 1.2 ECOTEC	1.2	59	4	07.06-08.14	Z12XEP	0,8	ZFR5F	5165	53	LPG 6	
Corsa D 1.2 ECOTEC	1.3	51	4	06.10-08.14	A12XEL	0,9	ZFR6V-G	8894			
Corsa D 1.2 ECOTEC	1.3	63	4	06.10-08.14	A12XER	0,9	ZFR6V-G	8894			
Corsa D 1.4 ECOTEC	1.4	64	4	01.10-08.14	A14XEL	0,9	ZFR6V-G	8894			
Corsa D 1.4 ECOTEC	1.4	66	4	07.06-08.14	Z14XEP	0,8	ZFR5F	5165	53	LPG 6	
Corsa D 1.4 ECOTEC	1.4	74	4	01.10-08.14	A14XER	0,9	ZFR6V-G	8894			
Corsa Van 1.4 ECOTEC	L08, L68	1.4	88	4	07.12-08.14	A14NEL	0,7	IFR7X7G	91039		
Corsa D 1.4 ECOTEC	1.4	88	4	08.12-08.14	A14NEL	0,7	IFR7X7G	91039			





l kW C
Y
I



Stock-N°

VLINE

LPG/CNG

OPEL

CORSA D

Corsa D 1.6 ECOTEC	1.6	110	4	02.07-08.14	Z16LEL	0,9	ZFR6BP-G	1748		LPG6
Corsa D 1.6	1.6	132	4	04.07-	Z16LET	1,0	PFR6T-10G	5542		
Corsa D 1.6 ECOTEC/OPC ECOTEC/VXR	1.6	141	4	11.06-08.14	A16LER, Z16LER	0,9	ZFR6BP-G	1748		LPG6
Corsa D 1.6 OPC ECOTEC/VXR	1.6	155	4	06.11-08.14	A16LES	0,9	ZFR6BP-G	1748		LPG6

CORSA E

Corsa E 1.0 ECOTEC	08, 68	1.0	66	3	09.14-	B10XFL	0,7	ILNAR8B7G	91970		
Corsa E 1.0 ECOTEC	08, 68	1.0	85	3	09.14-	B10XFT	0,7	ILNAR8B7G	91970		
Corsa E 1.2 ECOTEC		1.2	51	4	09.14-	B12XEL	0,9	ZFR6V-G	8894		
Corsa E 1.4 Turbo		1.4	74	4	09.14-	B14NEJ	0,7	IFR7X7G	91039		
Corsa 1.4	08, 68	1.4	110	4	03.15-	B14NEH, D14NEH	0,7	IFR7X7G	91039		

CORSA F

Corsa 1.2	68	1.2	55	3	07.19-	F12XEL(EB2FAD)	1,0	LZKR6AI-10G	97999		
-----------	-----------	-----	----	---	--------	----------------	-----	-------------	-------	--	--

FRONTERA A

Frontera A 2.0		2.0	85	4	09.91-08.95	C20NE OHC II	0,8	BKR5EK	7956	23	LPG 1
Frontera 2.0	52SUD2, 55SUD2	2.0	85	4	05.93-08.98	C20NE	0,8	BKR5EK	7956	23	LPG 1
Frontera A 2.0		2.0	85	4	02.95-06.98	X20SE OHC II	0,8	BKR5EK	7956	23	LPG 1
Frontera 2.4		2.4	92	4	09.91-02.95	C24NE CIH	0,7	BPR6HS	7022	3	BPR7HIX

FRONTERA B

Frontera B 2.2		2.2	100	4	10.98-12.04	X22SE	0,8	BKR5EK	7956	23	LPG 1
Frontera B 2.2 16V		2.2	100	4	10.98-08.98	X22XE DOHC	0,8	BKR5EK	7956	23	LPG 1
Frontera B 2.2		2.2	100	4	10.98-07.04	Y22SE	0,7	BPR6HS	7022	3	BPR7HIX
Frontera B 3.2 V6		3.2	151	6	08.98-07.04	Y32NE 6VD1	1,1	PFR5G-11	2647		

GT

GT Turbo 2.0		2.0	194	4	11.07-01.10	Z20LNF, Z20NHH	0,9	ILTR5D	5476		
--------------	--	-----	-----	---	-------------	----------------	-----	--------	------	--	--

INSIGNIA

Insignia 1.4 ECOTEC		1.4	103	4	08.11-	A14NET	0,7	IFR7X7G	91039		
Insignia 1.6 ECOTEC		1.6	85	4	07.08-	A16XER	0,7	ZFR6V-G	8894		
Insignia 1.6 ECOTEC/SIDI ECOTEC	35, 47	1.6	125	4	06.13-	A16XHT, B16SHL	0,7	ILNAR8B7G	91970		
Insignia 1.6 ECOTEC/SIDI ECOTEC	68	1.6	125	4	06.13-	A16XHT, B16SHL	0,7	ILNAR8B7G	91970		
Insignia 1.6 ECOTEC/SIDI ECOTEC	69	1.6	125	4	06.13-	A16XHT, B16SHL	0,7	ILNAR8B7G	91970		
Insignia 1.6 ECOTEC		1.6	132	4	07.08-	A16LET	0,9	ZFR6BP-G	1748		LPG 6
Insignia 1.8 VVT ECOTEC >> 91999999		1.8	103	4	07.08-03.17	A18XER, B18XER	0,8	ZFR5F	5165	53	LPG 6
Insignia 1.8 VVT ECOTEC A1000001 >> E1999999		1.8	103	4	07.08-03.17	A18XER, B18XER	0,9	ZFR6V-G	8894		
Insignia 2.0 ECOTEC		2.0	162	4	07.08-12.12	A20NHT	0,9	ILTR5D	5476		
Insignia 2.0 FlexFuel		2.0	184	4	07.11-	A20NFT	0,9	ILTR5D	5476		
Insignia 2.8 V6 ECOTEC		2.8	191	6	07.08-	A28NET	1,0	DILFR7B10G	97218		
Insignia 2.8 V6 OPC ECOTEC/VXR		2.8	239	6	07.09-	A28NER	1,0	DILFR7B10G	97218		

INSIGNIA A

Insignia Country Tourer 1.6 ECOTEC/SIDI ECOTEC	47	1.6	125	4	07.14-03.17	A16XHT, B16SHL	0,7	ILNAR8B7G	91970		
--	-----------	-----	-----	---	-------------	----------------	-----	-----------	-------	--	--

INSIGNIA B

Insignia 1.5 ECOTEC	68	1.5	103	4	03.17-	B15SFL, D15SFL	0,7	ILNAR8B7G	91970		
Insignia Sports Tourer 1.5 ECOTEC	35	1.5	103	4	03.17-	B15SFL, D15SFL	0,7	ILNAR8B7G	91970		
Insignia Sports Tourer 1.5 ECOTEC	35	1.5	121	4	03.17-	B15SFT, D15SFT	0,7	ILNAR8B7G	91970		
Insignia Country Tourer 1.5 ECOTEC	47	1.5	121	4	06.17-	B15SFT, D15SFT	0,7	ILNAR8B7G	91970		





l kW C
Y
I



Stock-N°

VLINE

LPG/CNG

OPEL

INSIGNIA B

Insignia 1.6	68	1.6	147	4	06.18-	D16SHT	0,7	ILNAR8B7G	91970		
Insignia Country Tourer 1.6	47	1.6	147	4	06.18-	D16SHT	0,7	ILNAR8B7G	91970		
Insignia Sports Tourer 1.6	35	1.6	147	4	06.18-	D16SHT	0,7	ILNAR8B7G	91970		

KADETT E

Kadett E 1.4		1.4	44	4	10.89-09.91	C14NZ OHC	0,9	BPR5ES	7422	6	LPG 2
Kadett E 1.4		1.4	44	4	10.89-09.93	14NV OHC I	0,8	BPR6ES	7822	2	LPG 2
Kadett E 1.4		1.4	44	4	01.90-08.91	E14LV OHC I	0,8	BPR6ES	7822	2	LPG 2
Kadett E 1.6		1.6	55	4	09.87-09.93	C16NZ OHC	0,9	BPR5ES	7422	6	LPG 2
Kadett E 1.6		1.6	55	4	09.87-09.91	E16NZ OHC	0,8	BPR6ES	7822	2	LPG 2
Kadett E 1.6		1.6	55	4	09.87-08.91	E16SE OHC	0,8	BPR6ES	7822	2	LPG 2
Kadett E 1.8		1.8	62	4	09.86-08.91	S18NV OHC II	0,8	BPR6ES	7822	2	LPG 2
Kadett E 1.8		1.8	66	4	09.90-09.91	C18NZ OHC II	0,9	BPR5ES	7422	6	LPG 2
Kadett E 2.0		2.0	85	4	09.86-09.91	20NE OHC	0,9	BPR5ES	7422	6	LPG 2
Kadett E 2.0		2.0	85	4	09.86-03.93	C20NE OHC	0,9	BPR5ES	7422	6	LPG 2
Kadett E 2.0		2.0	91	4	03.87-09.91	20SER OHC II	0,8	BPR6ES	7822	2	LPG 2
Kadett E 2.0		2.0	95	4	09.86-09.91	20SEH OHC II	0,8	BPR6ES	7822	2	LPG 2
Kadett E 2.0		2.0	110	4	03.88-09.91	C20XE DOHC	0,9	BKR6EK	2288	20	LPG 1
Kadett E 2.0		2.0	110	4	04.89-09.91	20XEJ DOHC	0,9	BKR6EK	2288	20	LPG 1

KARL

Karl LPG 1.0 LPG	C16	1.0	54	3	02.15-	B10XL	0,9	SILZNAR6D9	94051		
Karl 1.0 ECOTEC	C16	1.0	55	3	01.15-	B10XE	0,9	SILZNAR6D9	94051		

MERIVA A

Meriva A 1.4 ECOTEC		1.4	66	4	06.05-05.10	Z14XEP	0,8	ZFR5F	5165	53	LPG 6
Meriva A 1.6		1.6	64	4	05.03-05.10	Z16SE	0,8	BKR5EK	7956	23	LPG 1
Meriva A 1.6		1.6	74	4	05.03-05.10	Z16XE	0,8	BKR5EK	7956	23	LPG 1
Meriva A 1.6		1.6	77	4	01.06-05.10	Z16XEP	0,8	ZFR5F	5165	53	LPG 6
Meriva A 1.6 OPC/VXR		1.6	132	4	08.05-05.10	Z16LET	0,9	ZFR6BP-G	1748		LPG6
Meriva A 1.8 ECOTEC		1.8	92	4	05.03-05.10	Z18XE	0,8	BKR5EK	7956	23	LPG 1

MERIVA B

Meriva B 1.4 ECOTEC		1.4	74	4	03.10-	A14XER	0,9	ZFR6V-G	8894		
Meriva B 1.4 ECOTEC		1.4	88	4	03.10-	A14NEL, B14NEL	0,7	IFR7X7G	91039		
Meriva B 1.4 ECOTEC		1.4	103	4	03.10-	A14NET	0,7	IFR7X7G	91039		

MOKKA

Mokka 1.4 ECOTEC		1.4	103	4	06.12-	A14NET	0,7	IFR7X7G	91039		
Mokka 1.6 ECOTEC		1.6	85	4	06.12-	A16XER	0,9	ZFR6V-G	8894		
Mokka 1.8 ECOTEC		1.8	103	4	01.13-	A18XER	0,9	ZFR6V-G	8894		

MONTEREY A

Monterey A 3.2 V6 24V		3.2	130	6	04.92-12.98	6VDI SOHC	0,9	BKR6E	6962	28	LPG 1
-----------------------	--	-----	-----	---	-------------	-----------	-----	-------	------	----	-------

MONTEREY B

Monterey B 3.5 V6 24V		3.5	158	6	02.98-07.99	6VE1	1,1	BKR5EIX-11	5464		LPG 1
-----------------------	--	-----	-----	---	-------------	------	-----	------------	------	--	-------

OMEGA A

Omega A 1.8		1.8	60	4	09.86-03.94	18NV OHC II	0,8	BPR6ES	7822	2	LPG 2
Omega A 1.8		1.8	62	4	09.86-03.94	S18NV OHC II	0,8	BPR6ES	7822	2	LPG 2
Omega A 1.8		1.8	85	4	09.86-09.92	18SEH OHC II	0,8	BPR6ES	7822	2	LPG 2
Omega A 2.0		2.0	74	4	09.86-03.94	20NEJ	0,9	BKR6EK	2288	20	LPG 1





l kW C
Y
I



Stock-N°

VLINE

LPG/CNG

OPEL

OMEGA A

Omega A 2.0	2.0	74	4	09.86-03.94	Z0NE	0,9	BPR5ES	7422	6	LPG 2
Omega A 2.0	2.0	74	4	04.90-02.92	C20NEJ OHC	0,9	BKR6EK	2288	20	LPG 1
Omega A 2.0	2.0	85	4	09.86-03.94	C20NE OHC	0,9	BPR5ES	7422	6	LPG 2
Omega A 2.0	2.0	90	4	09.89-03.94	Z0SE OHC II	0,9	BKR6EK	2288	20	LPG 1
Omega A 2.4	2.4	92	6	09.88-03.94	C24NE CIH	0,7	BPR6HS	7022	3	BPR7HIX
Omega A 2.6	2.6	110	6	09.90-03.94	C26NE CIH	0,7	BPR6HS	7022	3	BPR7HIX
Omega A 3.0	3.0	115	6	03.87-03.94	C30NE CIH	0,7	BPR6HS	7022	3	BPR7HIX
Omega A 3.0	3.0	147	6	09.89-03.94	C30SE	0,9	BKR6EK	2288	20	LPG 1
Omega A 3.0	3.0	147	6	09.90-03.94	C30SEJ DOHC	0,9	BKR6EK	2288	20	LPG 1
Omega A 3.0 24V EVO	3.0	170	6	03.91-09.92	C30XEI DOHC	0,9	BKR6EK	2288	20	LPG 1

OMEGA B

Omega B 2.0	2.0	85	4	01.94-09.99	Z0SE OHC	0,8	BKR5EK	7956	23	LPG 1
Omega B 2.0	2.0	85	4	01.94-09.00	X20SE OHC	0,8	BKR5EK	7956	23	LPG 1
Omega B 2.0	2.0	100	4	01.94-09.00	X20XE DOHC	0,8	BKR5EK	7956	23	LPG 1
Omega B 2.2	2.2	106	4	09.99-09.00	Y22XE	0,8	BKR5EK	7956	23	LPG 1
Omega B 2.2	2.2	108	4	08.00-08.03	Z22XE	0,8	BKR5EK	7956	23	LPG 1
Omega B 2.5 V6	2.5	125	6	01.94-09.00	X25XE DOHC	0,8	BKR5EK	7956	23	LPG 1
Omega B 2.6	2.6	132	6	08.00-07.03	Y26SE	0,6	BKR5EQUA	3566		
Omega B 3.0	3.0	155	6	09.94-10.01	X30XE DOHC	0,8	BKR5EK	7956	23	LPG 1
Omega B 3.2	3.2	160	6	05.01-07.03	Y32SE	0,6	BKR5EQUA	3566		

SENATOR B

Senator B 2.6 i	2.6	110	6	09.90-09.93	C26NE CIH	0,7	BPR6HS	7022	3	BPR7HIX
Senator B 3.0 24V	3.0	150	6	09.89-06.93	C30SE DOHC	0,9	BKR6EK	2288	20	LPG 1
Senator B 3.6	3.6	145	6	08.89-09.93	C3,6NE irmscher, C3,6NEI irmscher	0,7	BPR6HS	7022	3	BPR7HIX
Senator B 4.0	4.0	200	6	01.91-09.93	C40SE irmscher	0,7	BPR6HS	7022	3	BPR7HIX

SIGNUM

Signum 1.8	1.8	85	4	05.03-12.06	Z18XEL	0,6	BKR5EQUA	3566			
Signum 1.8	1.8	90	4	05.03-07.05	Z18XE	0,6	BKR5EQUA	3566			
Signum 1.8	1.8	103	4	08.05-12.08	Z18XER	0,8	ZFR5F	5165	53	LPG 6	
Signum 2.0	2.0	129	4	05.03-12.08	Z20NET	1,0	PFR6T-10G	5542			
Signum 2.0	F48	2.0	129	4	05.03-12.08	Z20NET	1,0	PFR6D10G	1632		
Signum 2.2	2.2	108	4	05.03-05.05	Z22SE	1,0	LTR6B-10T	5948			
Signum 2.2 DGI	2.2	114	4	05.03-09.08	Z22YH	0,6	BKR5EQUA	3566			
Signum 2.8	2.8	169	6	09.05-12.08	Z28NEL	1,0	PLFR6C-10G	1959			
Signum 2.8	2.8	184	6	01.06-12.08	Z28NET	1,0	DILFR7B10G	97218			
Signum 3.2	3.2	155	6	05.03-07.05	Z32SE	0,6	BKR5EQUA	3566			

SINTRA

Sintra 2.2	2.2	104	4	09.96-09.99	X22XE DOHC	0,8	BKR5EK	7956	23	LPG 1
Sintra 3.0	3.0	155	6	09.96-09.99	X30XE DOHC	0,8	BKR5EK	7956	23	LPG 1

SPEEDSTER

Speedster 2.0	2.0	147	4	08.02-08.06	Z20LET	0,8	BKR5EK	7956	23	LPG 1
Speedster 2.2	2.2	108	4	04.00-09.05	Z22SE	1,0	LTR6B-10T	5948		

TIGRA A

Tigra A 1.4	1.4	63	4	08.97-12.00	C14SEL OHC	0,8	BKR5EK	7956	23	LPG 1
Tigra A 1.4	1.4	66	4	08.94-12.00	X14XE DOHC	0,8	BKR5EK	7956	23	LPG 1





l kW C
Y
I



Stock-N°

VLINE

LPG/CNG

OPEL

TIGRA A

Tigra A 1.6	1.6	74	4	06.97-08.98	C16SEL DOHC	0,8	BKR5EK	7956	23	LPG 1
Tigra A 1.6	1.6	78	4	08.94-08.98	X16XE DOHC	0,8	BKR5EK	7956	23	LPG 1

TIGRA B

Tigra B 1.4	1.4	66	4	06.04-12.10	Z14XEP	0,8	ZFR5F	5165	53	LPG 6
Tigra B 1.8	1.8	92	4	06.04-12.10	Z18XE	0,8	ZFR5F	5165	53	LPG 6

VECTRA A

Vectra A 1.4	1.4	55	4	09.88-09.92	14NV OHC I	0,8	BPR6ES	7822	2	LPG 2
Vectra A 1.6	1.6	52	4	09.93-08.95	X16SZ OHC	0,8	BKR5EK	7956	23	LPG 1
Vectra A 1.6	1.6	55	4	09.88-08.94	C16NZ	0,9	BPR5ES	7422	6	LPG 2
Vectra A 1.6	1.6	60	4	09.88-09.92	16SV OHC I	0,8	BPR6ES	7822	2	LPG 2
Vectra A 1.8	1.8	65	4	09.88-08.95	E18NVR OHC II	0,8	BPR6ES	7822	2	LPG 2
Vectra A 1.8	1.8	66	4	09.89-08.95	18SV, C18SV OHC	0,8	BPR6ES	7822	2	LPG 2
Vectra A 1.8	1.8	66	4	03.90-08.95	C18NZ OHC II	0,8	BKR5EK	7956	23	LPG 1
Vectra A 2.0	2.0	85	4	01.89-08.95	20NE, C20NE OHC	0,8	BKR5EK	7956	23	LPG 1
Vectra A 2.0	2.0	95	4	01.89-09.92	20SEH OHC II	0,8	BPR6ES	7822	2	LPG 2
Vectra A 2.0	2.0	100	4	08.92-08.95	20XE, C20XE, C20XE-LN	0,8	BKR5EK	7956	23	LPG 1
Vectra A 2.0	2.0	100	4	12.94-08.95	X20XEV DOHC	0,8	BKR5EK	7956	23	LPG 1
Vectra A 2.0	2.0	110	4	09.89-08.92	20XE, C20XE DOHC	0,9	BKR6EK	2288	20	LPG 1
Vectra A 2.0	2.0	150	4	09.92-08.95	C20LET DOHC	1,1	ZFR6F-11	4291		LPG 6
Vectra A 2.5	2.5	125	6	02.93-08.95	25XE	0,8	BKR5EK	7956	23	LPG 1
Vectra A 2.5	2.5	125	6	03.93-08.95	C25XE DOHC	0,8	BKR5EK	7956	23	LPG 1

VECTRA B

Vectra B 1.6	1.6	55	4	08.95-	16LZ2 OHC	0,8	BKR5EK	7956	23	LPG 1
Vectra B 1.6	1.6	55	4	08.95-09.00	X16SZR OHC	0,8	BKR5EK	7956	23	LPG 1
Vectra B 1.6	1.6	74	4	08.95-09.00	X16XEL DOHC	0,8	BKR5EK	7956	23	LPG 1
Vectra B 1.6	1.6	74	4	08.00-04.02	Z16XE DOHC	0,8	BKR5EK	7956	23	LPG 1
Vectra B 1.8	1.8	85	4	08.95-09.00	X18XE	0,8	BKR5EK	7956	23	LPG 1
Vectra B 1.8	1.8	85	4	03.99-09.00	X18XE1	0,8	BKR5EK	7956	23	LPG 1
Vectra B 1.8	1.8	85	4	08.00-04.02	Z18XEL	0,8	BKR5EK	7956	23	LPG 1
Vectra B 1.8	1.8	92	4	08.00-04.02	Z18XE	0,8	BKR5EK	7956	23	LPG 1
Vectra B 2.0	2.0	80	4	08.95-	20NEJ OHC	0,8	BKR5EK	7956	23	LPG 1
Vectra B 2.0	2.0	100	4	08.95-09.00	X20XEV	0,8	BKR5EK	7956	23	LPG 1
Vectra B 2.0	2.0	100	4	02.97-	C20SEL DOHC	0,8	BKR5EK	7956	23	LPG 1
Vectra B 2.2	2.2	106	4	10.99-	C22SEL DOHC	0,8	BKR5EK	7956	23	LPG 1
Vectra B 2.2	2.2	108	4	08.00-04.02	Z22SE	1,0	LTR6B-10T	5948		
Vectra B 2.5	2.5	125	6	08.95-09.00	X25XE DOHC	0,8	BKR5EK	7956	23	LPG 1
Vectra B 2.5	2.5	143	6	01.98-09.00	X25XE DOHC	0,8	BKR5EK	7956	23	LPG 1
Vectra B 2.6	2.6	125	6	08.00-07.03	Y26SE	0,6	BKR5EQUPA	3566		

VECTRA C

Vectra C 1.6	1.6	74	4	06.04-08.08	Z16XE DOHC	0,6	BKR5EQUPA	3566		
Vectra C 1.6	1.6	77	4	01.06-08.08	Z16XEP	0,8	ZFR5F	5165	53	LPG 6
Vectra C 1.8	1.8	81	4	04.02-07.03	Z18XEL	0,6	BKR5EQUPA	3566		
Vectra C 16V (VIN->31999999)	1.8	90	4	08.02-09.05	Z18XE	0,6	BKR5EQUPA	3566		
Vectra C 16V (VIN 41000001->)	1.8	90	4	08.02-09.05	Z18XE	0,8	ZFR5F	5165	53	LPG 6
Vectra C 1.8	1.8	103	4	01.06-08.08	Z18XER	0,8	ZFR5F	5165	53	LPG 6



e kW C
Y
I

Stock-N°

VLINE

LPG/CNG

OPEL**VECTRA C**

Vectra 2.0	F68, F69	2.0	129	4	02.03-08.08	Z20NET	1,0	PFR6D10G	1632		
Vectra C 2.0 GTS		2.0	129	4	03.03-08.08	Z20NET	1,0	PFR6T-10G	5542		
Vectra 2.0	F35	2.0	129	4	10.03-08.08	Z20NET	1,0	PFR6D10G	1632		
Vectra C 2.2		2.2	108	4	08.02-04.04	Z22SE	1,0	LTR6B-10T	5948		
Vectra C 2.2 DI		2.2	114	4	10.03-08.08	Z22YH	0,6	BKR5EQUPA	3566		
Vectra C 2.8		2.8	169	6	09.05-08.08	Z28NEL	1,0	PLFR6C-10G	1959		
Vectra C 2.8		2.8	184	6	08.06-08.08	Z28NET	1,0	PLFR6C-10G	1959		
Vectra C 2.8		2.8	188	6	08.05-08.06	Z28NET	1,0	PLFR6C-10G	1959		
Vectra 2.8 OPC	F69	2.8	206	6	10.06-08.08	Z28NET	1,0	DILFR7B10G	97218		
Vectra C 2.8		2.8	206	6	01.07-	Z28NET	1,0	DILFR7B10G	97218		
Vectra C 3.2 GTS		3.2	155	6	08.02-07.05	Z32SE	0,6	BKR5EQUPA	3566		

VIVARO

Vivaro 2.0		2.0	86	4	08.06-07.14	F4R 820	0,9	PFR6G-9	4377		PFR7G
Vivaro 2.0		2.0	88	4	09.01-07.06	F4R 720	0,9	PFR6G-9	4377		PFR7G

ZAFIRA A

Zafira A 1.6	F75	1.6	74	4	03.99-06.05	X16XE DOHC	0,8	BKR5EK	7956	23	LPG 1
Zafira A 1.6 ECOTEC	F75	1.6	74	4	08.00-	Z16XE	0,8	BKR5EK	7956	23	LPG 1
Zafira A 1.8	F75	1.8	85	4	03.99-09.00	X18XE DOHC	0,8	BKR5EK	7956	23	LPG 1
Zafira A 1.8	F75	1.8	85	4	04.99-09.00	X18XE1	0,8	BKR5EK	7956	23	LPG 1
Zafira A 1.8	F75	1.8	92	4	09.00-	Z18XE	0,8	BKR5EK	7956	23	LPG 1
Zafira A 2.0 Turbo OPC	F75	2.0	141	4	06.02-06.05	Z20LET	0,8	BKR5EK	7956	23	LPG 1
Zafira A 2.2	F75	2.2	108	4	08.00- .06	Z22SE	1,0	LTR6B-10T	5948		

ZAFIRA B

Zafira B 1.6 ECOTEC	A05	1.6	74	4	07.05-	Z16XE	0,8	BKR5EK	7956	23	LPG 1
Zafira B 1.6	A05	1.6	77	4	07.05-	Z16XEP	0,8	ZFR5F	5165	53	LPG 6
Zafira B 1.6	A05	1.6	85	4	01.08-	Z16XER	0,8	ZFR5F	5165	53	LPG 6
Zafira B 1.6	A05	1.6	85	4	01.08-07.10	A16XER	0,9	ZFR6V-G	8894		
Zafira B 1.8 ECOTEC	A05	1.8	103	4	07.05-	Z18XER	0,8	ZFR5F	5165	53	LPG 6
Zafira B 2.0	A05	2.0	147	4	07.05-	Z20LER	0,8	ZFR5F	5165	53	LPG 6
Zafira B 2.0 OPC	A05	2.0	177	4	09.05-	Z20LEH	0,8	PFR6T-G	6314		
Zafira B 2.2 DGI	A05	2.2	110	4	07.05-	Z22YH	0,6	BKR5EQUPA	3566		

ZAFIRA C

Zafira Tourer 1.6 SiDi	75	1.6	100	4	09.18-	D16SHJ	0,7	ILNAR8B7G	91970		
------------------------	----	-----	-----	---	--------	--------	-----	-----------	-------	--	--

ZAFIRA TOURER

Zafira Tourer 1.4 ECOTEC	P12	1.4	88	4	10.11-	A14NEL	0,7	IFR7X7G	91039		
Zafira Tourer 1.4 ECOTEC	P12	1.4	103	4	10.11-	A14NET	0,7	IFR7X7G	91039		
Zafira Tourer 1.6 ECOTEC	P12	1.6	110	4	10.11-	A16XNT	0,7	IFR7X7G	91039		
Zafira C Tourer 1.6 ECOTEC/SIDI/ SIDI ECOTEC (VIN F1000001->; VIN F2000001->)	75	1.6	125	4	12.12-	A16XHT, B16SHL	0,7	ILNAR8B7G	91970		
Zafira C Tourer 1.6 ECOTEC/SIDI ECO- TEC (VIN F1000001->; VIN F2000001->)	75	1.6	147	4	07.13-	A16SHT, B16SHT	0,7	ILNAR8B7G	91970		
Zafira Tourer 1.8 ECOTEC	P12	1.8	103	4	12.11-	A18XER	0,9	ZFR6V-G	8894		

PEUGEOT**1007**

1007 1.4		1.4	55	4	04.05-	TU3A, TU3JP	1,1	BKR6E-11	2756	14	LPG 1
----------	--	-----	----	---	--------	-------------	-----	----------	------	----	-------





e kW C
Y
I



Stock-N°

VLINE

LPG/CNG

PEUGEOT

1007

1007 1.4 16V	1.4	65	4	10.05-	ET3J4	0,9	LZKAR7A	6799	54	
1007 1.6	1.6	81	4	04.05-	TU5JP4-NFU	0,9	LFR6B	6677	47	LPG 7

106

106 1.3	1CMFZ2	1.3	72	4	08.91-03.96	TU2J2	0,9	BCPR6ET	2197		LPG 3
106	1AKFZ2, 1CKFZ2	1.4	69	4	08.91-03.96	TU3J2	0,9	BKR6EK	2288	20	LPG 1
106 1.4	1AKFZ2, 1CKFZ2	1.4	69	4	08.91-03.96	TU3J2	0,8	BCPR7ES	3330		BCPR7EIX
106 1.6	1ANFZ2, 1CNFZ2	1.6	65	4	06.93-06.96	TU5JP	0,9	BCPR6ET	2197		LPG 3
106 1.6	1ANFZ2, 1CNFZ2	1.6	65	4	06.93-06.96	TU5JP	0,8	BCPR7ES	3330		BCPR7EIX
106 1.6	1CJFZ2	1.6	76	4	01.94-04.96	TU5J2	0,8	BCPR7ES	3330		BCPR7EIX

106 I

106 XN		0,9	37	4	08.91-12.92	TU9-C1A	0,9	BCP5ES	7496	16	LPG 3
106i XN, XA, Kid		0,9	37	4	07.92-06.95	TU9M-CDZ	0,9	BCPR5ES	6130	32	LPG 3
106i XN, XA, Kid		0,9	37	4	07.95-03.96	TU9M-CDZ	0,8	BKR5EK	7956	23	LPG 1
106 XN, XR		1.1	38	4	08.91-12.92	TU1-H1A	0,9	BCP5ES	7496	16	LPG 3
106i XN, XR, XT, Green		1.1	44	4	07.92-06.95	TU1M-HDZ	0,9	BCPR5ES	6130	32	LPG 3
106i XN, XR, XT, Green		1.1	44	4	07.95-03.96	TU1M-HDZ	0,9	BKR6EK	2288	20	LPG 1
106 Rallye		1.3	74	4	11.93-03.96	TU2J2-MFZ	0,9	BKR6EK	2288	20	LPG 1
106 XR, XT		1.4	51	4	08.91-12.92	TU3.2-K2D	0,9	BCP6ES	4930	17	LPG 3
106 Xsi		1.4	55	4	08.91-12.92	TU3JP-KFX	0,9	BKR6EK	2288	20	LPG 1
106i XR, XS, XT		1.4	55	4	07.92-06.95	TU3MC-KDX	0,9	BCPR5ES	6130	32	LPG 3
106 Xsi		1.4	55	4	07.92-03.96	TU3JP cat.-KFX	0,9	BKR6EK	2288	20	LPG 1
106i XR, XS, XT		1.4	55	4	07.95-03.96	TU3MC-KDX	0,9	BKR6EK	2288	20	LPG 1
106i XS, XT, Griffes		1.6	66	4	07.94-03.96	TU5JP-NFZ	0,9	BKR6EK	2288	20	LPG 1
106 Xsi		1.6	74	4	12.93-06.95	TU5J2-NFW	0,9	BKR6ES	3783	28	LPG 1
106 Xsi		1.6	74	4	07.95-05.96	TU5J2-NFW	0,9	BKR6EK	2288	20	LPG 1

106 II

106i, Kid		1.0	37	4	04.96-	TU9M-CDZ, Y	0,8	BKR5EK	7956	23	LPG 1
106i		1.1	44	4	04.96-	TU1M + HDZ	0,9	BKR6EK	2288	20	LPG 1
106 Pop Art		1.1	44	4	05.00-	TU1JP	0,9	BKR6EZ	4619	38	LPG 1
106i		1.4	55	4	04.96-12.99	TU3JP-KFX	0,9	BKR6EK	2288	20	LPG 1
106i		1.4	55	4	01.00-	TU3JP-KFX	0,9	BKR6EZ	4619	38	LPG 1
106i		1.6	66	4	04.96-12.99	TU5JP-NFZ	0,9	BKR6EK	2288	20	LPG 1
106i		1.6	66	4	01.00-	TU5JP-NFZ	0,9	BKR6EZ	4619	38	LPG 1
106 Rallye		1.6	74	4	06.96-	TU5J2-NFW	0,9	BKR6EK	2288	20	LPG 1
106 16V S16, Gti		1.6	88	4	06.96-12.99	TU5J4-NFX	0,9	BKR6EK	2288	20	LPG 1
106 16V S16, Gti		1.6	88	4	01.00-	TU5J4-NFX	0,9	BKR6EZ	4619	38	LPG 1

107

107 12V		1.0	50	3	06.05-	384F	1,1	LFR6C-11	5788	48	
107		1.1		4	09.04-	TU1A	0,9	BKR6EZ	4619	38	LPG 1
107		1.4		4	09.04-	TU3A	0,9	BKR6EZ	4619	38	LPG 1

108

108 1.0 VTi 68		1.0	50	3	.14-	1KR	1,0	LZKR6AI-10G	97999		
----------------	--	-----	----	---	------	-----	-----	-------------	-------	--	--





l kW C Y I



Stock-N°

VLINE

LPG/CNG

PEUGEOT

108

108 1.0 Vti (Euro 5 / Euro 6)	PSCFB2, PSCFB3, PSCFBB, PSCFBC	1.0	51	3	05.14-	1KR	1,1	DF6H-11B	5989		
108 1.0 Vti (Euro 5 / Euro 6)	PSCFB4, PSCFBD	1.0	53	3	05.18-	1KR	1,1	DF6H-11B	5989		
108 1.2 VTI 82		1.2	60	3	.14-	EB2D	1,0	LZKR6AI-10G	97999		

2008

2008 1.2 82 Vti		1.2	60	3	03.13-	EB2	1,0	LZKR6AI-10G	97999		
2008 1.6 VTI	CU5FS0	1.6	85	4	05.13-	EP6C	0,8	PLZKBR7B8G	91530		
2008 1.6 120 Vti		1.6	88	4	03.13-	EP6C	0,8	PLZKBR7B8G	91530		

205

205 XE,GL,Junior		0.9	33	4	07.87-12.92	TU9	0,9	BCP5ES	7496	16	LPG 3
205 XE,GL,Junior		0.9	33	4	07.92-	TU9M Cat.	0,9	BCPR5ES	6130	32	LPG 3
205 XR,XL,GL,GR		1.1	34	4	07.87-12.92	TU1	0,9	BCP5ES	7496	16	LPG 3
205 GR,Color Line		1.1	44	4	07.92-06.95	TU1M Cat.	0,9	BCPR5ES	6130	32	LPG 3
205 GR,Color,Sacre ` Num		1.1	44	4	03.95-	TU1.M Cat.	0,9	BKR6EK	2288	20	LPG 1
205 Entreprise XA, XRA		1.1		4	.88-	E1	0,9	BCP6ES	4930	17	LPG 3
205 Rallye		1.3	75	4	03.88-06.92	TU2.4	0,8	BKUR7ET	7873		
205 Enterprise,XA,XRA		1.3		4	.88-	G1	0,9	BCP6ES	4930	17	LPG 3
205 XR,GR,SR,CJ		1.4	43	4	07.87-12.92	TU3 , TU3A	0,9	BCP5ES	7496	16	LPG 3
205 XR,GR,SR,CJ		1.4	55	4	07.92-	TU3FM Cat.	0,9	BCPR5ES	6130	32	LPG 3
205 XR,XS		1.4	55	4	07.92-06.95	TU3MC Cat.	0,9	BCPR6ES	2330	12	LPG 3
205 XR,GR,SR,SJ,Sacre N°		1.4	55	4	07.95-	TU3.MC Cat.	0,9	BKR6EK	2288	20	LPG 1
205 XT,XS,GT,CT		1.4	62	4	07.87-12.92	TU3S	0,9	BCP6ES	4930	17	LPG 3
205 Rallye		1.4		4	03.88-06.92	TU2.4	0,8	BKUR7ET	7873		
205 XS,GT,Auto		1.6	65	4	07.92-	XU5.M Cat.	0,9	BCPR5ES	6130	32	LPG 3
205 GTi / CTi		1.6	83	4	07.87-06.92	XU5JA	0,9	BCP6ES	4930	17	LPG 3
205 Entreprise XA,XRA		1.6		4	.88-	E1E, G1E	0,9	BCP6ES	4930	17	LPG 3
205 GR,XS,XT,Auto		1.6		4	07.90-12.92	XU5.1C	0,9	BCP6ES	4930	17	LPG 3
205 Gentry		1.9	75	4	07.92-	XU9.J1 Cat.	0,9	BCPR5ES	6130	32	LPG 3
205 GTi		1.9	88	4	07.92-	XU9.JA Cat.	0,9	BCPR5ES	6130	32	LPG 3
205 GTi / Gentry		1.9	94	4	-12.92	XU9.JA	0,9	BCP6ES	4930	17	LPG 3

206

206		1.1	44	4	09.98-12.99	TU1JP-HFZ,HFY	0,9	BKR6EK	2288	20	LPG 1
206		1.1	44	4	01.00-	TU1JP-HFZ;HFY	0,9	BKR6EZ	4619	38	LPG 1
206	2AKFVA, 2AKFWA, 2AKFWE, 2AKFWF, 2AKFWP, 2AKFWR, 2AKFXE, 2AKFXP, 2CKFVA, 2CKFWA, 2CKFWE, 2CKFWF, 2CKFWP, 2CKFWR, 2CKFXE, 2CKFXP	1.4	55	4	08.98-12.12	TU3A	0,9	BKR6EZ	4619	38	LPG 1
206		1.4	55	4	09.98-12.99	TU3JP-KFX	0,9	BKR6EK	2288	20	LPG 1
206		1.4	55	4	01.00-	TU3JP-KFX	0,9	BKR6EZ	4619	38	LPG 1





l kW C
Y
I



Stock-N°

VLINE

LPG/CNG

PEUGEOT

206

206	2RKFA	1.4	55	4	03.07-12.12	TU3A	0,9	BKR6EZ	4619	38	LPG 1
206		1.6	66	4	09.98-08.00	TU5JP-NFZ	0,9	BKR6EK	2288	20	LPG 1
206		1.6	66	4	01.00-	TU5JP-NFZ	0,9	BKR6EZ	4619	38	LPG 1
206 1.6	2ANFUA, 2ANFUB, 2ANFUF, 2ANFUR, 2CNFUA, 2CNFUB, 2CNFUF	1.6	80	4	07.00-04.09	TU5JP4	0,9	LFR6B	6677	47	LPG 7
206 1.6 BiFuel	2ANFUF, 2CNFUF	1.6	80	4	07.00-04.09	TU5JP4	0,9	LFR6B	6677	47	LPG 7
206 16V CC		1.6	81	4	03.01-	TU5JP4-NFU	0,9	LFR6B	6677	47	LPG 7
206 Coupe 16V XS, XT		1.6	81	4	03.01-	TU5JP4	0,9	LFR6B	6677	47	LPG 7
206 CC 1.6	2DNFUF, 2DNFUR	1.6	81	4	09.01-12.07	TU5JP4	0,9	LFR6B	6677	47	LPG 7
206 Coupe 16V		2.0	102	4	04.99-	EW10J4	0,9	LFR5B	7113	46	LPG 7
206 2.0 S16 RC		2.0	132	4	10.02-	EW10J4S- RFK	0,9	LFR5B	7113	46	LPG 7
206 S16		2.0	132	4	10.02-	EW10J4S-RFK	0,9	LFR5B	7113	46	LPG 7

206 & SW

206 & SW		1.1	44	4	09.98-12.99	TU1JP-HFY, HFY	0,9	BKR6EK	2288	20	LPG 1
206 & SW		1.1	44	4	01.00-	TU1JP-HFY, HFY	0,9	BKR6EZ	4619	38	LPG 1
206 & SW		1.4	55	4	09.98-12.99	TU3JP-KFX	0,9	BKR6EK	2288	20	LPG 1
206 & SW		1.4	55	4	01.00-	TU3JP-KFX	0,9	BKR6EZ	4619	38	LPG 1
206 & SW		1.4	66	4	.04-	ET3J4-KFU	0,9	LZKAR7A	6799	54	
206 & SW		1.6	66	4	09.98-12.99	TU5JP-NFZ	0,9	BKR6EK	2288	20	LPG 1
206 & SW		1.6	66	4	01.00-	TU5JP-NFZ	0,9	BKR6EZ	4619	38	LPG 1
206 & SW 16V, CC		1.6	81	4	03.01-	TU5JP4-NFU	0,9	LFR6B	6677	47	LPG 7
206 & SW S16, GT, CC		2.0	101	4	04.99-	EW10J4 RFR RFN	0,9	LFR5B	7113	46	LPG 7

206 PLUS

206 Plus 1.1 Urban, Trendy		1.1	44	4	03.09-	TU1A	0,9	BKR6EZ	4619	38	LPG 1
206 Plus 1.4	2LKFTA, 2MKFTA	1.4	54	4	09.10-06.13	TU3AE5	0,9	BKR6EZ	4619	38	LPG 1
206 Plus 1.4 Urban, Trendy		1.4	55	4	03.09-	TU3A-KFV	0,9	BKR6EZ	4619	38	LPG 1

207

207		1.4	55	4	05.06-	TU3A-KFV	0,9	BKR6EZ	4619	38	LPG 1
207 16V		1.4	55	4	.07-	EP3	0,8	PLZKBR7B8G	91530		
207 16V		1.4	66	4	04.06-	ET3J4-KFU	0,9	LZKAR7A	6799	54	
207 1.4 Vti 95		1.4	70	4	10.07-	EP3, EP3C	0,8	PLZKBR7B8G	91530		
207 1.4 VTi (For hot climate zones)	WA8FR0, WC8FR0	1.4	72	4	10.09-12.12	EP3C	0,8	PLZKBR7B8G	91530		
207 1.4 VTi (Not for hot climate zones)	WA8FR0, WC8FR0	1.4	72	4	10.09-12.12	EP3C	0,8	PLZKBR7B8G	91530		
207 1.4 VTi	WA8FR0, WC8FR0	1.4	72	4	10.09-12.12	EP3C	0,8	PLZKBR7B8G	91530		
207 SW 1.4 VTi	WK8FR0	1.4	72	4	11.09-12.12	EP3C	0,8	PLZKBR7B8G	91530		
207 16V		1.6	75	4	04.06-	EP6	0,8	PLZKBR7B8G	91530		
207 1.6 VTi	WC5FWC	1.6	81	4	09.08-12.12	EP6	0,8	PLZKBR7B8G	91530		
207 1.6 Vti 120		1.6	88	4	02.07-	EP6, EP6C	0,8	PLZKBR7B8G	91530		
207 1.6 VTi (For hot climate zones)	WA5FWBF, WA5FWCF	1.6	88	4	03.07-12.12	EP6	0,8	PLZKBR7B8G	91530		
207 1.6 VTi (Not for hot climate zones)	WA5FWBF, WA5FWCF	1.6	88	4	03.07-12.12	EP6	0,8	PLZKBR7B8G	91530		





l kW C
Y I



Stock-N°

VLINE

LPG/CNG

PEUGEOT

207

207 1.6 16V		1.6	110	4	06.06-	EP6DT	0,8	PLZKBR7B8G	91530		
207 SW 1.6 THP	WK5FXC	1.6	110	4	02.07-12.12	EP6DT	0,8	PLZKBR7B8G	91530		
207		1.6	110	4	.07-	EP6DT	0,8	PLZKBR7B8G	91530		
207 1.6 THP 155		1.6	115	4	10.09-	EP6DT, EP6CDT	0,8	PLZKBR7B8G	91530		
207		1.6	129	4	11.06-	EP6DTS	0,8	PLZKBR7B8G	91530		
207 RC		1.6	129	4	04.07-	EP6DTS	0,8	PLZKBR7B8G	91530		

207 CC

207 CC 1.6 VTi	WD5FS0, WD5FWB, WD5FWC	1.6	88	4	11.06-10.13	EP6, EP6C	0,8	PLZKBR7B8G	91530		
207 CC 1.6 THP	WD5FX8, WD5FXC	1.6	110	4	11.06-12.12	EP6DT	0,8	PLZKBR7B8G	91530		
207 CC 1.6 THP	WD5FXC	1.6	115	4	09.07-12.12	EP6DT	0,8	PLZKBR7B8G	91530		

207 PLUS

207	WAKFWC, WCKFWC	1.4	55	4	01.12-10.13	TU3A	0,9	BKR6EZ	4619	38	LPG 1
-----	-------------------	-----	----	---	-------------	------	-----	--------	------	----	-------

207 SW

207	WKKFVC	1.4	54	4	08.07-12.12	TU3A, TU3AE5	0,9	BKR6EZ	4619	38	LPG 1
207 SW 1.4 BiFuel	WKKFVC	1.4	54	4	08.07-12.12	TU3A	0,9	BKR6EZ	4619	38	LPG 1
207	WKKFUC	1.4	65	4	08.07-12.12	ET3J4	0,9	LZKAR7A	6799	54	
207 SW 1.4 VTi/VVT	WK8FR0, WK8FSC	1.4	70	4	08.07-10.13	EP3, EP3C	0,8	PLZKBR7B8G	91530		
207 SW 1.4 VTi	WK8FR0	1.4	72	4	11.09-12.12	EP3C	0,8	PLZKBR7B8G	91530		
207 SW 1.6 VTi	WK5FS0, WK5FWB, WK5FWC, WK5FWF	1.6	88	4	08.07-10.13	EP6, EP6C	0,8	PLZKBR7B8G	91530		
207 SW 1.6 THP	WK5FXC	1.6	110	4	02.07-12.12	EP6DT	0,8	PLZKBR7B8G	91530		
207 SW 1.6 THP RC	WK5FYC	1.6	128	4	02.07-12.12	EP6DTS	0,8	PLZKBR7B8G	91530		

208

208 1.0 68 VTi		1.0	50	3	03.12-	EB0	1,0	LZKR6AI-10G	97999		
208 1.2 82 VTi		1.2	60	3	03.12-	EB2	1,0	LZKR6AI-10G	97999		
208 1.4 95 VTi		1.4	70	4	03.12-	EP3C	0,8	PLZKBR7B8G	91530		
208 1.4 BiFuel	CA8FP0, CC8FP0	1.4	70	4	10.13-	EP3C	0,8	PLZKBR7B8G	91530		
208 1.6 120 VTi		1.6	88	4	03.12-	EP6C	0,8	PLZKBR7B8G	91530		
208 1.6 155 THP		1.6	115	4	03.12-	EP6CDT	0,8	PLZKBR7B8G	91530		
208 1.6 Gti		1.6	147	4	08.12-	EP6CDTX	0,8	ILZKBR7B8G	97968		
208 1.6 GTi	CA5FU8	1.6	147	4	08.12-	EP6CDTX	0,8	ILZKBR7B8G	97968		

3008

3008 1.6 Vti 120		1.6	88	4	05.09-	EP6	0,8	PLZKBR7B8G	91530		
3008 1.6 VTi	OU5FS6, OU5FW6	1.6	88	4	06.09-	EP6C	0,8	PLZKBR7B8G	91530		
3008 THP		1.6	110	4	05.09-	EP6DT	0,8	PLZKBR7B8G	91530		
3008 1.6 THP	OU5FEM, OU5FET, OU5FXM	1.6	110	4	06.09-08.16	EP6CDTMD	0,8	ILZKBR7B8G	97968		
3008 1.6 THP 155		1.6	115	4	05.09-	EP6CDT	0,8	PLZKBR7B8G	91530		
3008 1.6 THP	OU5FM8	1.6	120	4	09.10-08.16	EP6CDTM	0,8	ILZKBR7B8G	97968		

301

301 1.2 72 VTi		1.2	52	3	.12-	EB2M	1,0	LZKR6AI-10G	97999		
301 1.6 115 VTi		1.6	84	4	.12-	EC5	0,8	PLZKBR7B8G	91530		





l kW C
Y I



Stock-N°

VLINE

LPG/CNG

PEUGEOT

301

301 1.6 VTi	DDNFP0, DDNFP6, DDNFP9, DDNFPT	1.6	85	4	11.12-	EC5	0,9	LFR6B	6677	47	LPG 7
301 1.6 LPG	DDNFP0	1.6	85	4	07.14-	EC5	0,9	LFR6B	6677	47	LPG 7

306

306		1.1	44	4	02.93-06.95	TU1M-HDZ	0,9	BCPR5ES	6130	32	LPG 3
306		1.1	44	4	07.95-04.97	TU1M-HDZ	0,8	BKR5EK	7956	23	LPG 1
306		1.1		4	.96-	TU1.M +	0,9	BKR6EK	2288	20	LPG 1
306		1.4	55	4	02.93-06.95	TU3.MC-KDX	0,9	BCPR5ES	6130	32	LPG 3
306		1.4	55	4	07.95-12.03	TU3JP-KFX	0,9	BKR6EK	2288	20	LPG 1
306		1.4	55	4	01.00-10.03	TU3JP-KFX	0,9	BKR6EZ	4619	38	LPG 1
306 1.6	7ANFTP, 7ANFZ2, 7ANFZP, 7CNFZ2, 7CNFZP	1.6	65	4	05.93-10.00	TU5JP	0,9	BCPR6ET	2197		LPG 3
306 1.6	7ANFTP, 7ANFZ2, 7ANFZP, 7CNFZ2, 7CNFZP	1.6	65	4	05.93-10.00	TU5JP	0,8	BCPR7ES	3330		BCPR7EIX
306 1.6	7BNFZ2, 7BNFZP	1.6	65	4	06.94-10.00	TU5JP	0,9	BCPR6ET	2197		LPG 3
306 1.6	7BNFZ2, 7BNFZP	1.6	65	4	06.94-10.00	TU5JP	0,8	BCPR7ES	3330		BCPR7EIX
306 Cabrio 1.6	7DNFZ2, 7DNFZP	1.6	65	4	08.96-06.00	TU5JP	0,9	BCPR6ET	2197		LPG 3
306		1.6	66	4	02.93-12.99	TU5JP-NFZ	0,9	BKR6EK	2288	20	LPG 1
306		1.6	66	4	01.00-10.03	TU5JP-NFZ	0,9	BKR6EZ	4619	38	LPG 1
306 / Cabrio		1.8	74	4	02.93-03.95	XU7JP-LFZ	0,9	BCPR5ES	6130	32	LPG 3
306		1.8	74	4	04.95-10.03	XU7JP-LFZ	0,8	BKR5EK	7956	23	LPG 1
306 16V		1.8	81	4	04.97-10.03	XU7JP4-LFY	0,8	BKR5EK	7956	23	LPG 1
306		2.0	89	4	02.93-03.95	XU10.J2-RFX	0,9	BCPR5ES	6130	32	LPG 3
306		2.0	89	4	04.95-04.97	XU10.J2-RFX	0,8	BKR5EK	7956	23	LPG 1
306		2.0	89	4	-03.97	XU10.J4-RFY	0,9	BKR6ES	3783	28	LPG 1
306		2.0	98	4	04.97-	XU10J4R-RFV	0,8	BKR5EK	7956	23	LPG 1
306 Le Mans		2.0	110	4	11.93- .96	XU10J4	0,9	BKR6ES	3783	28	LPG 1
306		2.0	120	4	07.96-10.03	XU10J4RS-RFS	0,9	BKR5EZ	7642	36	LPG 1
306 2.0	7CRFG2, 7CRFSW	2.0	120	4	07.96-05.01	XU10J4RS	0,9	BCPR6ET	2197		LPG 3
306 2.0 16V Le Mans		2.0		4	11.93- .96	XU10J4	0,9	BKR6ES	3783	28	LPG 1

307

307		1.4	55	4	04.01-05.05	TU3JP-KFX	0,9	BKR6EZ	4619	38	LPG 1
307 & SW XR		1.4	55	4	04.01- .99	TU3JP-KFX	0,9	BKR6EZ	4619	38	LPG 1
307 & SW 16V		1.4	66	4	03.04-	ET3J4 KFJ, ET3J4-KFU	0,9	LZKAR7A	6799	54	
307		1.6	81	4	04.01-	TU5JP4-NFU	0,9	LFR6B	6677	47	LPG 7
307 & SW 16V		1.6	81	4	04.01-	TU5JP4-NFU	0,9	LFR6B	6677	47	LPG 7
307 1.6	3BNFUC	1.6	81	4	07.06-04.12	TU5JP4	0,9	LFR6B	6677	47	LPG 7
307		2.0	100	4	04.01-	EW10J4 RFN	0,9	LFR5B	7113	46	LPG 7
307 & SW 16V		2.0	100	4	04.01-	EW10J4 RFN	0,9	LFR5B	7113	46	LPG 7
307 Coupe 16V		2.0	102	4	.03-	EW10J4	0,9	LFR5B	7113	46	LPG 7
307 CC 2.0 CVT	3BRFJC, 3BRFJF	2.0	103	4	01.05-04.09	EW10A	0,9	LFR6B	6677	47	LPG 7





l kW C
Y
I



Stock-N°

VLINE

LPG/CNG

PEUGEOT

307

307 2.0 CVVT	3ARFJC, 3ARFJF, 3CRFJC, 3CRFJF	2.0	103	4	03.05-11.07	EW10A	0,9	LFR6B	6677	47	LPG 7
307 SW 2.0 CVVT	3ERFJC, 3ERFJF, 3HRFJC, 3HRFJF	2.0	103	4	03.05-04.08	EW10A	0,9	LFR6B	6677	47	LPG 7
307 & SW		2.0	104	4	09.06-	EW10A	0,9	LFR5B	7113	46	LPG 7
307 2.0 16V SW		2.0	104	4	09.06-	EW10A	0,9	LFR5B	7113	46	LPG 7
307 Coupe 16V		2.0	132	4	03.04-	EW10J4S-RFK	0,9	LFR5B	7113	46	LPG 7

307 CC

307	3BRFNC, 3BRFNF	2.0	100	4	10.03-06.05	EW10J4	0,9	LFR5B	7113	46	LPG 7
307 CC 2.0 CVVT	3BRFJC, 3BRFJF	2.0	103	4	01.05-04.09	EW10A	0,9	LFR5B	7113	46	LPG 7
307	3BRFKC	2.0	130	4	10.03-04.09	EW10J4S	0,9	LFR5B	7113	46	LPG 7

307 SW

307	3EKFWB	1.4	55	4	04.02-09.03	TU3JP	0,9	BKR6EZ	4619	38	LPG 1
307	3EKFUB	1.4	65	4	10.03-07.07	ET3J4	0,9	LZKAR7A	6799	54	
307	3ENFUB, 3ENFUE, 3HNFUB, 3HNFUE	1.6	80	4	04.02-04.08	TU5JP4	0,9	LFR6B	6677	47	LPG 7
307 SW 1.6 Bioflex	3ENFUB	1.6	83	4	09.07-04.09	TU5JP4	0,9	LFR6B	6677	47	LPG 7
307	3ERFNB, 3ERFNE, 3ERFNP, 3HRFNB, 3HRFNE, 3HRFNP	2.0	100	4	04.02-06.05	EW10J4	0,9	LFR5B	7113	46	LPG 7
307 SW 2.0 CVVT	3ERFJC, 3ERFJF, 3HRFJC, 3HRFJF	2.0	103	4	03.05-04.08	EW10A	0,9	LFR5B	7113	46	LPG 7
307	3ERFKN	2.0	130	4	06.05-04.08	EW10J4S	0,9	LFR5B	7113	46	LPG 7

308

308 1.6 Bioflex	4ANFUC, 4CNFUC	1.6	80	4	03.08-10.14	TU5JP4	0,9	LFR6B	6677	47	LPG 7
308 1.6 VTi	LWNFPA	1.6	85	4	05.15-	EC5	0,9	LFR6B	6677	47	LPG 7
308 SW 1.6 THP	L45FAG	1.6	92	4	03.14-	EP6CDT	0,8	PLZKBR7B8G	91530		
308 1.6 THP	4C5FV8, 4C5FVA	1.6	115	4	07.09-10.14	EP6CDT	0,8	ILZKBR7B8G	97968		
308 CC 1.6 THP	4B5FV8, 4B5FVA	1.6	115	4	07.09-12.14	EP6CDT	0,8	ILZKBR7B8G	97968		
308 SW 1.6 THP	4E5FV8, 4E5FVA	1.6	115	4	10.09-10.14	EP6CDT	0,8	ILZKBR7B8G	97968		
308 SW 1.6 THP	L45FVG	1.6	115	4	03.14-	EP6CDT	0,8	PLZKBR7B8G	91530		
308 1.6 THP	4C5FMA	1.6	120	4	01.12-03.15	EP6CDTM	0,8	ILZKBR7B8G	97968		
308 2.0 Bioflex	4CRFJC	2.0	103	4	01.08-12.12	EW10A	0,9	LFR5B	7113	46	LPG 7

308 CC

308 CC 1.6 VTi	4B5FS0	1.6	88	4	02.09-12.14	EP6C	0,8	PLZKBR7B8G	91530		
308 CC 1.6 VTi	4B5FS0, 4B5FW0	1.6	88	4	02.09-12.14	EP6	0,8	PLZKBR7B8G	91530		
308 CC 2.0 CVVT	4BRFJ8, 4BRFJA	2.0	103	4	07.09-12.14	EW10A	0,9	LFR5B	7113	46	LPG 7

308 CC I

308 CC I 1.6 THP 16V		1.6	105	4	03.09-	EP6DT	0,8	PLZKBR7B8G	91530		
308 CC I 1.6 THP 16V		1.6	110	4	03.09-	EP6DT	0,8	PLZKBR7B8G	91530		





l kW C
Y
I



Stock-N°

VLINE

LPG/CNG

PEUGEOT

308 CC I

308 CC I 1.6 THP 200	1,6	147	4	10.10-	EP6CDTX	0,8	ILZKBR7B8G	97968		
----------------------	-----	-----	---	--------	---------	-----	------------	-------	--	--

308 I

308 I 1.4 16V	1,4	55	4	09.07-	EP3	0,8	PLZKBR7B8G	91530		
308 I 1.4 Vti 95	1,4	70	4	09.07-	EP3, EP3C	0,8	PLZKBR7B8G	91530		
308 I 1.4 Vti 95	1,4	72	4	12.09-	EP3C	0,8	PLZKBR7B8G	91530		
308 I 1.6 16V	1,6	80	4	09.07-	EP6	0,8	PLZKBR7B8G	91530		
308 I 1.6 16V	1,6	88	4	09.07-	EP6, EP6C	0,8	PLZKBR7B8G	91530		
308 I 1.6 16V	1,6	103	4	09.07-	EP6DT	0,8	PLZKBR7B8G	91530		
308 I 1.6 THP 150	1,6	110	4	09.07-	EP6DT	0,8	PLZKBR7B8G	91530		
308 I 1.6 THP 155	1,6	115	4	07.09-	EP6CDT	0,8	PLZKBR7B8G	91530		
308 I 1.6 THP 175	1,6	130	4	09.07-	EP6DTS	0,8	PLZKBR7B8G	91530		
308 I 1.6 GTi	1,6	147	4	07.10-	EP6CDTX	0,8	ILZKBR7B8G	97968		

308 II

308 II 1.2 82 Vti	1,2	60	3	09.13-	EB2	1,0	LZKR6AI-10G	97999		
308 II 1.6 125 THP	1,6	92	4	09.13-	EP6CDT	0,8	PLZKBR7B8G	91530		
308 II 1.6 155 THP	1,6	115	4	09.13-	EP6CDT	0,8	PLZKBR7B8G	91530		
308 1.6 GTi THP	L35GPM	1,6	184	4	08.15-	EP6FDTR	0,8	ILZKR8C8G	90909	
308 1.6 GTi THP	L35GNM	1,6	200	4	06.15-	EP6FDTR	0,8	ILZKR8C8G	90909	

309

309 Vital	1,1	40	4	07.92-	TU1M Cat.	0,9	BCPR5ES	6130	32	LPG 3
309 GE, GL, GR	1,1	40	4	-12.92	E1A	0,9	BCP5ES	7496	16	LPG 3
309 XA, XR, XL	1,1	40	4	-12.92	E1A	0,9	BCP5ES	7496	16	LPG 3
309 XE, GE	1,1	40	4	-12.92	TU1	0,9	BCP5ES	7496	16	LPG 3
309 GE, GL, GR, XE, XL, XR, XA	1,3	47	4	10.86-12.93	G1A	0,9	BCP5ES	7496	16	LPG 3
309 XL, GL	1,4	44	4	10.86-12.93	TU3	0,9	BCP5ES	7496	16	LPG 3
309 GRX	1,4	55	4	10.86-12.93	TU3M Cat.	0,9	BCPR5ES	6130	32	LPG 3
309 SR, GRX	1,6	65	4	07.92-	XU5M Cat.	0,9	BCPR5ES	6130	32	LPG 3
309 GR, GRX, SR, SX, XS, XR	1,6	68	4	07.89-12.92	XU5.2C	0,9	BCP6ES	4930	17	LPG 3
309 XS, SX	1,9	80	4	07.89-06.92	XU9.2C	0,9	BCP6ES	4930	17	LPG 3
309 XS, SX	1,9	80	4	07.92-	XU9M Cat.	0,9	BCPR5ES	6130	32	LPG 3
309 GTi	1,9	88	4	07.92-	XU9.JA Cat.	0,9	BCPR5ES	6130	32	LPG 3
309 GTi	1,9	94	4	-12.92	XU9.JA	0,9	BCP6ES	4930	17	LPG 3
309 GTi 16V	1,9	110	4	07.92-	XU9.J4 Cat.	0,9	BCPR6ET	2197		LPG 3
309 GTi 16V	1,9	118	4	-06.92	XU9.J4	0,9	BCP6ET	4563		LPG 3

4007

4007 2.0 Mivec	VVMMCF	2,0	108	4	11.10-03.13	4B11	0,8	FR6EI	2687		FR6EI
4007 2.4		2,4	125	4	02.07-	VUSFZC, VUSFZF, VVSFZC, VVSFZF	0,8	FR5EI	1313		FR6EI

4008

4008 2.0		2,0	110	4	04.12-	4B11	0,8	FR6EI	2687		FR6EI
----------	--	-----	-----	---	--------	------	-----	-------	------	--	-------

405

405 GL		1,4	55	4	07.92-06.95	TU3M-KDX Cat.	0,9	BCPR5ES	6130	32	LPG 3
405	4EK2D2, 4EKDX2	1,4	55	4	08.92-08.94	TU32	0,9	BCP5ES	7496	16	LPG 3
405	4BKDX2	1,4	55	4	08.92-08.94	TU3MC	0,9	BKR6EK	2288	20	LPG 1
405	4EK2D2, 4EKDX2	1,4	55	4	08.92-08.94	TU3MC	0,9	BKR6EK	2288	20	LPG 1





l kW C
Y
I



Stock-N°

VLINE

LPG/CNG

PEUGEOT

405

405		1.4	55	4	07.95-04.97	TU3M-KDX Cat.	0,9	BKR6EK	2288	20	LPG 1
405 GL,GR,SR		1.6	55	4	07.87-06.92	XU51C	0,9	BCP5ES	7496	16	LPG 3
405 GL,GR,SR		1.6	65	4	07.92-06.94	XU5M-BDY Cat.	0,9	BCPR5ES	6130	32	LPG 3
405		1.6	66	4	04.95-	XU5JP-BFZ	0,8	BKR5EK	7956	23	LPG 1
405 1.6	4BB2A2, 4BB2A4	1.6	68	4	08.92-08.94	XU52C	0,8	BCPR7ES	3330		BCPR7EIX
405	4ENFU2	1.6	80	4	08.92-05.97	TU5JP4	0,9	LFR6B	6677	47	LPG 7
405 Sillage,Style		1.6		4	07.94-03.95	XU5JP-BFZ Cat.	0,9	BCPR5ES	6130	32	LPG 3
405 Signa, Style		1.8	74	4	07.92-03.95	XU7JP-LFZ Cat.	0,9	BCPR5ES	6130	32	LPG 3
405		1.8		4	04.95-	XU7JP-LFZ	0,8	BKR5EK	7956	23	LPG 1
405 1.9	4ED6D2, 4ED6D4	1.9	80	4	08.92-12.95	XU9J2	0,8	BCPR7ES	3330		BCPR7EIX
405 GR,SR		1.9		4	07.87-06.92	XU92C	0,9	BCP6ES	4930	17	LPG 3
405 GRi, SRi, Si, X4		1.9		4	07.87-06.92	XU9J2-D6A	0,9	BCP6ES	4930	17	LPG 3
405 MI16,X4		1.9		4	07.90-06.92	XU9J4-D6C	0,9	BCPR6ET	2197		LPG 3
405 Signature, STI		2.0	90	4	07.92-03.95	XU10J2-RFX Cat.	0,8	BKR5EK	7956	23	LPG 1
405 Mi16		2.0	110	4	07.92-	XU10J4-RFY Cat.	0,9	BKR6ES	3783	28	LPG 1
405 2.0	4BRFT2	2.0	110	4	06.94-10.95	XU10J4	0,8	BCPR7ES	3330		BCPR7EIX
405 2.0	4BRFY2	2.0	112	4	08.92-10.95	XU10J4	0,8	BCPR7ES	3330		BCPR7EIX
405 2.0	4ERGZ7	2.0	144	4	08.92-12.95	XU10J4TE	0,9	BCPR6ET	2197		LPG 3
405 T16		2.0	147	4	09.92-04.97	XU10J4TE-RGZ Cat.	0,9	BKR6EK	2288	20	LPG 1
405 Signature,STI		2.0		4	07.92-03.95	XU10J2-RFX Cat.	0,9	BCPR5ES	6130	32	LPG 3

406

406		1.6	66	4	10.95-06.04	XU5JP-BFZ	0,8	BKR5EK	7956	23	LPG 1
406		1.8	66	4	10.95-06.04	XU7JP-L6A	0,8	BKR5EK	7956	23	LPG 1
406		1.8	81	4	10.95-06.04	XU7JP4-LFY	0,8	BKR5EK	7956	23	LPG 1
406		2.0	97	4	10.95-06.04	XU10J4R-RFV	0,8	BKR5EK	7956	23	LPG 1
406 Coupe 16V		2.0	97	4	06.97-03.99	XU10J4R-RFV	0,8	BKR5EK	7956	23	LPG 1
406 Coupe 16V		2.0	101	4	04.99-02.05	EW10J4 RFR	0,9	LFR5B	7113	46	LPG 7
406		2.0	107	4	07.96-03.99	XU10J2TE-RGX	0,9	BKR6EK	2288	20	LPG 1
406 Coupe 16V		2.2	118	4	05.00-02.05	EW12J4-3FZ	0,9	LFR5B	7113	46	LPG 7
406 24V V6		3.0	140	6	10.96-02.05	ES9J4-XFZ	0,9	BKR6EK	2288	20	LPG 1
406 Coupe V6		3.0	143	6	06.97-02.05	ES9J4-XFZ	0,9	BKR6EK	2288	20	LPG 1
406 Coupe V6		3.0	154	6	06.00-11.04	ES9J4S-XFX	1,1	PLFR5A-11	6240		LPG 7

406 PHASE 2

406 Phase 2		1.8	66	4	04.99-02.05	XU7JB-LFX	0,9	BKR6EK	2288	20	LPG 1
406 Phase 2		1.8	81	4	04.99-06.04	XU7JP4-LFY	0,8	BKR5EK	7956	23	LPG 1
406 Phase 2		1.8	86	4	09.00-06.04	EW7J4-6FZ	0,9	LFR5B	7113	46	LPG 7
406 Phase 2		2.0	101	4	04.99-02.05	EW10J4 RFR RFN	0,9	LFR5B	7113	46	LPG 7
406 Phase 2		2.2	117	4	04.99-02.05	EW12J4-3FZ	0,9	LFR5B	7113	46	LPG 7
406 Phase 2		3.0	140	6	04.99-02.05	ES9J4-XFZ	0,9	BKR6EK	2288	20	LPG 1
406 Phase 2		3.0	154	6	10.00-02.05	ES9J4S-XFX	1,1	PLFR5A-11	6240		LPG 7

407

407 1.8		1.8	85	4	04.04-07.05	EW7J4-6FZ	0,9	LFR5B	7113	46	LPG 7
407	6D6FYC	1.8	92	4	08.05-12.10	EW7A	0,9	LFR5B	7113	46	LPG 7
407 2.0		2.0	100	4	05.04-07.05	EW10J4 RFN	0,9	LFR5B	7113	46	LPG 7





l kW C
Y
I



Stock-N°

VLINE

LPG/CNG

PEUGEOT

407

407 16V		2.0	104	4	09.06-12.10	EW10A	0,9	LFR5B	7113	46	LPG 7
407 2.0 16V		2.0		4	09.06-12.10	EW10A	0,9	LFR5B	7113	46	LPG 7
407 2.2		2.2	116	4	04.04-07.05	EW12J4-3FZ	0,9	LFR5B	7113	46	LPG 7
407 2.2 16V		2.2	120	4	08.05-12.10	EW12J4-3FZ	0,9	LFR5B	7113	46	LPG 7
407 3.0 V6 24V		3.0	155	6	04.04-12.10	ES9A-XFV	1,1	PLFR5A-11	6240		LPG 7
407 V6		3.0	155	6	04.04-12.10	ES9A-XFV	1,1	PLFR5A-11	6240		LPG 7

5008

5008 1.6 Vti 120		1.6	88	4	09.09-	EP6	0,8	PLZKBR7B8G	91530		
5008 1.6 VTi	0E5FW0, 0U5FS0, 0U5FW0	1.6	88	4	09.09-	EP6C	0,8	PLZKBR7B8G	91530		
5008 1.6 THP	0U5FVM, 0U5FXM, 0U5FXT	1.6	110	4	02.12-	EP6DT	0,8	PLZKBR7B8G	91530		
5008 1.6 THP 155		1.6	115	4	09.09-	EP6CDT	0,8	PLZKBR7B8G	91530		

508

508 1.6 VTi	8D5FH8	1.6	85	4	11.10-12.18	EP6C	0,8	PLZKBR7B8G	91530		
508 SW 1.6 VTi	8E5FH8, 8E5FHA	1.6	85	4	11.10-12.18	EP6C	0,8	PLZKBR7B8G	91530		
508 1.6 Vti 120		1.6	88	4	11.10-	EP6C	0,8	PLZKBR7B8G	91530		
508 1.6 THP	8D5FEA, 8D5FN8, 8D5FNA	1.6	110	4	11.10-12.18	EP6CDT, EP6CDTM	0,8	PLZKBR7B8G	91530		
508 SW 1.6 THP	8E5FEA, 8E5FN8, 8E5FNA	1.6	110	4	11.10-12.18	EP6CDT, EP6CDTM	0,8	PLZKBR7B8G	91530		
508 1.6 THP 155		1.6	115	4	11.10-	EP6CDT	0,8	PLZKBR7B8G	91530		

605

605 SL		2.0	79	4	07.89-06.92	XU102C-R2A	0,9	BCP6ES	4930	17	LPG 3
605 2.0	6BR5A2	2.0	84	4	06.89-09.99	XU102C	0,8	BCPR7ES	3330		BCPR7EIX
605 SRi		2.0	89	4	09.89-12.92	XU10J2-R6A	0,9	BCPR6ES	2330	12	LPG 3
605 SLI		2.0	89	4	07.92-07.94	XU10J2-RFZ Cat.	0,9	BCPR5ES	6130	32	LPG 3
605 2.0	6BRFZ2, 6BRFZ4	2.0	89	4	08.94-09.99	XU10J2	0,8	BCPR7ES	3330		BCPR7EIX
605		2.0	99	4	08.94-05.99	XU10J4R-RFV	0,8	BKR5EK	7956	23	LPG 1
605 SRTi Turbo		2.0	104	4	12.92-05.99	XU10J2TE-RGX	0,9	BKR6EK	2288	20	LPG 1
605 3.0	6BUFZ2, 6BUFZ4	3.0	123	6	10.89-09.99	ZPJUKZ	0,9	BCPR6ET	2197		LPG 3
605 SR, SV		3.0	125	6	07.89-06.97	ZPJ-SFZ Cat.	0,9	BCPR6ET	2197		LPG 3
605 3.0		3.0	140	6	07.97-05.99	ES9J4-XFZ	0,9	BKR6EK	2288	20	LPG 1
605 SV 24V		3.0	147	6	07.89-06.97	ZPJ4-SKZ Cat.	0,9	BCPR6ET	2197		LPG 3
605 3.0	6BUKZ2	3.0	147	6	08.89-09.99	ZPJ4UKZ	0,9	BCPR6ET	2197		LPG 3

607

607 2.0		2.0	100	4	02.00-11.04	EW10J4 RFN	0,9	LFR5B	7113	46	LPG 7
607 2.2 16V		2.2	118	4	05.00-	EW12J4-3FZ	0,9	LFR5B	7113	46	LPG 7
607 3.0 V6		3.0	152	6	05.00-	ES9J4S-XFX	1,1	PLFR5A-11	6240		LPG 7

806

806		1.8	74	4	10.96-06.00	XU7JP-LFW	0,8	BKR5EK	7956	23	LPG 1
806 16V		2.0	89	4	06.94-03.95	XU10J2-RFU	0,9	BCPR5ES	6130	32	LPG 3
806		2.0	90	4	04.95-05.00	XU10J2-RFU	0,8	BKR5EK	7956	23	LPG 1
806	AFRFVC	2.0	97	4	05.98-09.00	XU10J4R	0,8	BKR5EK	7956	23	LPG 1
806		2.0	101	4	06.00-	EW10J4 RFR	0,9	LFR5B	7113	46	LPG 7





e kW C
Y
I



Stock-N°

VLINE

LPG/CNG

PEUGEOT

PARTNER

Partner 1.6 VTi	3 5FK	1.6	72	4	11.10-	EP6CB	0,8	PLZKBR7B8G	91530		
Partner	5ENFUE	1.6	80	4	09.00-10.02	TU5JP4	0,9	LFR6B	6677	47	LPG 7
Partner	5ENFUE, GENFUB, GENFUC	1.6	80	4	09.00-05.08	TU5JP4	0,9	LFR6B	6677	47	LPG 7
Partner 1.6 Bioflex	5ENFUE	1.6	80	4	09.00-10.02	TU5JP4	0,9	LFR6B	6677	47	LPG 7
Partner 1.6 Bioflex	5 NFU	1.6	80	4	09.00-10.02	TU5JP4	0,9	LFR6B	6677	47	LPG 7
Partner 1.6	5 NFU	1.6	80	4	09.00-10.02	TU5JP4	0,9	LFR6B	6677	47	LPG 7
Partner	3B9FUW, 3BNFU0	1.6	80	4	04.08-	TU5JP4	0,9	LFR6B	6677	47	LPG 7
Partner 1.6	3 NFU	1.6	80	4	04.08-	TU5JP4	0,9	LFR6B	6677	47	LPG 7
Partner Origin 1.6	G NFU	1.6	81	4	09.11-12.13	TU5JP4	0,9	LFR6B	6677	47	LPG 7
Partner Origin 1.6	G NFU	1.6	81	4	09.11-12.15	TU5JP4	0,9	LFR6B	6677	47	LPG 7
Partner Tepee 1.6 VTi	3 5FS	1.6	88	4	09.09-	EP6C	0,8	PLZKBR7B8G	91530		
Partner	3BNFR0, 3BNFRB, 3BNFRW	1.6	88	4	04.10-	TU5JP4B	0,9	LFR6B	6677	47	LPG 7
Partner 1.6 VTi	3J5FS0	1.6	88	4	04.10-	EP6C	0,8	PLZKBR7B8G	91530		
Partner 1.6	3 5FS	1.6	88	4	04.10-	EP6C	0,8	PLZKBR7B8G	91530		
Partner		1.8	66	4	07.97-	XU7JB-LFX	0,9	BKR6EK	2288	20	LPG 1

PARTNER MULTISPACE

Partner Multispace		1.4	55	4	01.97-12.99	TU3JP-KFX, KFW	0,9	BKR6EK	2288	20	LPG 1
Partner Multispace		1.4	55	4	01.00-	TU3JP-KFX, KFW	0,9	BKR6EZ	4619	38	LPG 1
Partner Multispace		1.6	81	4	02.01-	TU5JP4-NFU	0,9	LFR6B	6677	47	LPG 7
Partner Multispace		1.8	66	4	07.97-	XU7JB-LFX	0,9	BKR6EK	2288	20	LPG 1

PARTNER ORIGIN

Partner	GBKFWC	1.4	55	4	08.08-12.13	TU3JP	0,9	BKR6EZ	4619	38	LPG 1
Partner	GJKFWC	1.4	55	4	08.08-12.13	TU3JP	0,9	BKR6EZ	4619	38	LPG 1
Partner	GNNFUC	1.6	81	4	09.11-12.13	TU5JP4	0,9	LFR6B	6677	47	LPG 7

PARTNER TEPEE

Partner	3JN6A0	1.6	66	4	06.08-	TU5JP4	0,9	LFR6B	6677	47	LPG 7
Partner	3JNFU0	1.6	80	4	04.08-	TU5JP4	0,9	LFR6B	6677	47	LPG 7

RCZ

RCZ 1.6 THP	4J5FEJ	1.6	110	4	01.11-12.15	EP6CDTMD	0,8	ILZKBR7B8G	97968		
RCZ 1.6 155 THP		1.6	115	4	03.10-	EP6CDT	0,8	PLZKBR7B8G	91530		
RCZ 1.6 200 THP		1.6	147	4	06.10-	EP6CDTX	0,8	ILZKBR7B8G	97968		
RCZ 1.6 THP	4J5FGM	1.6	199	4	06.13-	EP6CDTR	0,8	ILZKR8C8G	90909		

PORSCHE

911 (964)

911 Turbo (964)		3.3	236	6	.91- .92	M30.69	0,8	BPR8EIX	6684		BPR9EIX
911 Turbo S (964)		3.3	280	6	.92- .92	M30.69SL	0,8	BPR8EIX	6684		BPR9EIX
911 Carrera 2 (964)		3.6	184	6	.90- .93	M64.01, M64.02	0,9	BCPR7ET	2164		BCPR7EIX
911 Carrera 4 (964)		3.6	184	6	.90- .93	M64.01	0,9	BCPR7ET	2164		BCPR7EIX
911 Carrera RS America (964)		3.6	184	6	.92- .92	M64.01	0,9	BCPR7ET	2164		BCPR7EIX
911 Turbo Look (964)		3.6	184	6	.92- .92	M64.01, M64.02	0,9	BCPR7ET	2164		BCPR7EIX
911 Carrera RS (964)		3.6	191	6	.92- .92	M64.03	0,9	BCPR7ET	2164		BCPR7EIX
911 Turbo 3.6 (964)		3.6	265	6	.93- .93	M64.50	0,9	BKR6EK	2288	20	LPG 1





l kW C Y I



Stock-Nº

VLINE

LPG/CNG

PORSCHE

911 (993)

911 Carrera 2 (993)	3.6	184	6	.94- .95	M64.01, M64.02	0,9	BCPR7ET	2164		BCPR7EIX
911 Carrera 2 Speedster (993)	3.6	184	6	.94- .94	M64.01, M64.02	0,9	BCPR7ET	2164		BCPR7EIX
911 Carrera 4 Turbo Look (993)	3.6	184	6	.94- .94	M64.01	0,9	BCPR7ET	2164		BCPR7EIX
911 Carrera (993)	3.6	200	6	.93- .97	M64.07, M64.08, M64.23, M64.24	0,9	BCPR7ET	2164		BCPR7EIX
911 Carrera (993)	3.6	200	6	.94- .95	M64.05, M64.06	0,9	BCPR7ET	2164		BCPR7EIX
911 Carrera 4 (993)	3.6	200	6	.95- .95	M64.05	0,9	BCPR7ET	2164		BCPR7EIX
911 Carrera (993)	3.6	210	6	.97- .97	M64.21, M64.22	0,9	BCPR7ET	2164		BCPR7EIX
911 Carrera 4 (993)	3.6	210	6	.97- .98	M64.21	0,9	BCPR7ET	2164		BCPR7EIX
911 Carrera 4 S (993)	3.6	210	6	.97- .98	M64.21	0,9	BCPR7ET	2164		BCPR7EIX
911 Carrera S (993)	3.6	210	6	.97- .98	M64.21, M64.22	0,9	BCPR7ET	2164		BCPR7EIX
911 Carrera 4s (993)	3.6	221	6	.96- .96	M64.21	0,9	BCPR7ET	2164		BCPR7EIX
911 Turbo 3.6 (993)	3.6	265	6	.94- .94	M64.50	0,9	BKR6EK	2288	20	LPG 1
911 Turbo Biturbo (993)	3.6	300	6	.95- .97	M64.60	0,9	BKR6EK	2288	20	LPG 1
911 Turbo 3.6 Biturbo (993)	3.6	300	6	.98- .98	M64.60	0,9	BKR6EK	2288	20	LPG 1
911 GT2 (993)	3.6	316	6	.96- .98	M64.60R	0,9	BKR6EK	2288	20	LPG 1
911 Carrera (993)	3.8	210	6	.96- .96	M64.05, M64.06	0,9	BCPR7ET	2164		BCPR7EIX
911 Carrera 4 (993)	3.8	210	6	.96- .96	M64.05	0,9	BCPR7ET	2164		BCPR7EIX
911 Carrera RS America (993)	3.8	221	6	.95- .96	M64.20	0,9	BCPR7ET	2164		BCPR7EIX

911 (996)

911 Carrera (996)	3.4	221	6	.98- .98	M96.01	1,5	BKR6EQUP	3199	30	LPG 1	
911 Carrera 2 (996)	3.4	221	6	.99- .00	M96.01	1,5	BKR6EQUP	3199	30	LPG 1	
911 Carrera 4 (996)	3.4	221	6	.99- .00	M96.02	1,5	BKR6EQUP	3199	30	LPG 1	
911 Carrera 2 (996)	3.4	221	6	.01- .04	M96.04	1,5	BKR6EQUP	3199	30	LPG 1	
911 Carrera 4 (996)	3.4	221	6	.01- .00	M96.04	1,5	BKR6EQUP	3199	30	LPG 1	
911 3.6 Carrera 4	996	3.6	235	6	08.01-01.05	M9603	1,5	BKR7EQUP	4285		
911 3.6	996	3.6	235	6	12.01-08.05	M9603	1,5	BKR7EQUP	4285		
911 Carrera (996)	3.6	235	6	.01- .03	M96.03	1,5	BKR7EQUP	4285			
911 GT3 (996)	3.6	265	6	.00- .00	M96.76	0,9	BKR6EK	2288	20	LPG 1	
911 GT3 (996)	3.6	280	6	.01- .04	M96.76, M 96.79	0,7	BKR7EIX	2667		BKR8EIX	
911 Turbo (996)	3.6	309	6	.01- .06	M96.70	0,9	BCPR7ET	2164		BCPR7EIX	
911 GT2 (996)	3.6	340	6	.01- .04	M96.70S	0,9	BKR7EKC	7354			

911 (997)

911 3.6 Carrera	997	3.6	235	6	08.04-07.05	M9605	1,5	BKR7EQUP	4285		
911 3.6 Carrera	997	3.6	235	6	02.05-07.05	M9605	1,5	BKR7EQUP	4285		
911 3.6 Carrera 4	997	3.6	239	6	07.04-12.08	M9605	1,5	BKR7EQUP	4285		
911 Carrea (997)		3.6	239	6	.04-	M96.05	1,5	BKR7EQUP	4285		
911 3.6 Carrera 4	997	3.6	239	6	01.06-12.08	M9605	1,5	BKR7EQUP	4285		
911 Carrea S (997)		3.8	261	6	.04-	M97.01	1,5	BKR7EQUP	4285		
911 3.8 Carrera 4S	997	3.8	261	6	07.06-12.08	M9701	1,5	BKR7EQUP	4285		
911 3.8 Carrera S	997	3.8	280	6	08.05-12.08	M9701S	1,5	BKR7EQUP	4285		
911 3.8 Carrera 4S	997	3.8	280	6	11.06-12.08	M9701S	1,5	BKR7EQUP	4285		

928

928 S4/CS		5.0	235	8	08.86-07.91	M 28.41, M28.42	0,8	BPR6ES	7822	2	LPG 2
928 GT		5.0	243	8	01.89-07.91	M 28.47	0,8	BPR6ES	7822	2	LPG 2
928 GTS		5.4	250	8	08.91-11.95	M 28.49, M 28.50	0,8	BPR6ES	7822	2	LPG 2





e kW C
Y
I



Stock-N°

VLINE

LPG/CNG

PORSCHE

944

944 2.5 Turbo	2.5	184	4	09.87-07.91	M 44.52	0,8	BPR6ES	7822	2	LPG 2
944 Turbo	2.5	184	4	09.87-07.91	M 44.52	0,8	BPR6ES	7822	2	LPG 2
944 S2	3.0	155	4	12.88-07.91	M 44.41	0,8	BPR7ES	2023	19	BPR8EIX

968

968	3.0	176	4	08.91-11.95	M 44.43, M 44.44	0,8	BPR6ES	7822	2	LPG 2
968 Turbo S	3.0	224	4	01.93-11.95		0,8	BKR6ES	3783	28	LPG 1

BOXSTER 986

Boxster	986	2.5	150	6	09.96-08.99	M 96.20	0,9	BKR6EK	2288	20	LPG 1
Boxster	986	2.7	162	6	09.99-07.02	M 96.22	1,5	BKR6EQUP	3199	30	LPG 1
Boxster	986	2.7	168	6	07.02-	M 96.23	1,5	BKR6EQUP	3199	30	LPG 1
Boxster S	986	3.2	185	6	09.99-07.02	M 96.21	1,5	BKR6EQUP	3199	30	LPG 1
Boxster S	986	3.2	191	6	07.02-	M 96.24	1,5	BKR6EQUP	3199	30	LPG 1

BOXSTER 987

Boxster	987	2.7	176	6	12.04-	M 96.25	1,5	BKR7EQUP	4285		
Boxster	987	2.7	180	6	07.06-	M 97.20	1,5	BKR7EQUP	4285		
Boxster	987	2.9	188	6	.08-	M 96.25, M 96.20	1,5	BKR7EQUP	4285		
Boxster S	987	3.2	206	6	09.04-08.06	M 96.26	1,5	BKR7EQUP	4285		
Boxster S	987	3.4	217	6	09.06-	M 97.21	1,5	BKR7EQUP	4285		
Boxster 3.4 S	987	3.4	223	6	01.08-12.10	M9722	1,5	BKR7EQUP	4285		
Boxster S	987	3.4	228	6	.08-	M 97.26, M 97.21	1,5	BKR7EQUP	4285		
Boxster Spyder	987	3.4	236	6	.08-	M 97.21	1,5	BKR7EQUP	4285		

CARRERA

Carrera GT	5.7	450	10	07.03-	M 80.01	0,9	PFR8B-9	3169		
------------	-----	-----	----	--------	---------	-----	---------	------	--	--

CAYENNE I

Cayenne I 3.2	955	3.2	184	6	10.03-12.06	M 02.2Y BFD	0,9	IZKR7B	7563		
Cayenne I 3.6	955	3.6	213	6	02.07-05.10	M55.01	0,9	ILZKR7A	1961		
Cayenne I 4.5 S	955	4.5	250	8	08.02-12.06	M 48.00	1,5	BKR6EQUP	3199	30	LPG 1
Cayenne I 4.5 Turbo	955	4.5	331	8	08.02-12.06	M 48.50	0,8	PFR7Q	7963		
Cayenne I 4.5 Turbo S	955	4.5	368	8	01.04-10.05	M 48.50S	0,8	PFR7Q	7963		

CAYENNE II

Cayenne II 3.6	958	3.6	220	6	06.10-	M55.02	0,8	ILZKR8A	94290		
----------------	-----	-----	-----	---	--------	--------	-----	---------	-------	--	--

CAYMAN

Cayman	2.7	180	6	09.06-	M 97.20	1,5	BKR7EQUP	4285			
Cayman	987C	2.9	195	6	.08-	M 97.20	1,5	BKR7EQUP	4285		
Cayman S	3.4	217	6	11.05-	M 97.21	1,5	BKR7EQUP	4285			
Cayman 3.4 S	987	3.4	223	6	08.08-12.12	M9722	1,5	BKR7EQUP	4285		
Cayman S	987C	3.4	236	6	.08-	M 97.21	1,5	BKR7EQUP	4285		

RAM

1500

RAM 1500 Crew Cab Pickup (DS); Extended Cab Pickup (DS)	5.7	291	8	01.11-12.12	EZH	1,1	LZFR5CI-11	92145		
RAM 1500 Standard Cab Pickup (DS)	5.7	291	8	01.11-	EZH	1,1	LZFR5CI-11	92145		
RAM 1500 Standard-, Extended- and Crew Cab Pickup (DS)	5.7	295	8	09.12-	EZH	1,1	LZFR5CI-11	92145		

2500

RAM 2500 Crew Cab Pickup, Extended Crew Cab Pickup (DJ)	5.7	286	8	01.11-	EZC	1,1	LZFR5CI-11	92145		
---	-----	-----	---	--------	-----	-----	------------	-------	--	--





l kW C
Y
I



Stock-N°

VLINE

LPG/CNG

RAM

2500

RAM 2500 Standard- and Crew Cab Pick-up (DJ)	5.7	286	8	09.13-	EZF	1,1	LZFR5CI-11	92145		
--	-----	-----	---	--------	-----	-----	------------	-------	--	--

RAM 2018

RAM 1500 5.7 HEMI	DT	5.7	295	8	12.18-	EZH	1,1	LZFR5CI-11	92145	
-------------------	----	-----	-----	---	--------	-----	-----	------------	-------	--

RENAULT

AVANTIME

Avantime 16V Turbo	2.0	121	4	04.02-05.03	F4R760, F4R761	0,8	BKR6EIX	6418		LPG 1
Avantime 2.0i 16V Turbo	2.0	121	4	04.02-05.03	F4RT760, F4RT762	0,9	PFR6G-9	4377		PFR7G
Avantime 24V V6	3.0	152	6	09.01-05.03	L7X720, L7X721, L7X722	1,0	PFR6E-10	3688		LPG 1

CAPTUR

Captur 0.9 TCe 90	0.9	66	3	06.13-	H4B 400, H4B408	0,7	ILKAR7J7G	91121		
Captur 1.2 TCe	J5AU	1.2	87	4	01.16-	H5F408, H5F412	0,7	ILKAR7F7G	90061	
Captur 1.2 TCe 120	1.2	88	4	06.13-	H5F 403	0,7	ILKAR7F7G	90061		
Captur 1.3 TCe	J5NJ	1.3	96	4	03.18-	H5H450	0,7	SILZKFR8D7G	90912	
Captur 1.3 TCe	J5NK	1.3	110	4	03.18-	H5H450	0,7	SILZKFR8D7G	90912	

CAPTUR PHASE I

Captur 0.9 TCe	J5JK, J5M1, J5MA, J5MH	0.9	66	3	06.13-	H4B400, H4B408	0,7	ILKAR7F7G	90061	
----------------	------------------------	-----	----	---	--------	----------------	-----	-----------	-------	--

CLIO

Clio 1	1.1	35	4	06.90-03.96	C1E 700	0,9	BP5ES	6511	8	LPG 2
Clio 1	1.2	40	4	06.90-02.98	E5F710, E5F716, E7F706, E7F700	0,9	BCP5ES	7496	16	LPG 3
Clio 1	1.2	40	4	11.94-03.96	C3G 720	0,9	BP5ESZ	4691		LPG 2
Clio 1	1.2	44	4	01.96-06.97	D7F 730	0,9	BK5ESZ	5675		
Clio 1	1.2	44	4	07.97-02.98	D7F 730	0,8	BKR5EK	7956	23	LPG 1
Clio 1	1.4	55	4	06.90-02.98	E6J712, E6J713	0,9	BCP5ES	7496	16	LPG 3
Clio 1	1.4	55	4	06.90-	E7J718, E7J719	0,9	BCP5ES	7496	16	LPG 3
Clio 1	1.4	55	4	04.96-	E7J 754	0,9	BCP5ES	7496	16	LPG 3
Clio 1	1.4	58	4	06.90-02.98	E7J710, E7J711	0,9	BCP5ES	7496	16	LPG 3
Clio 1	1.7	66	4	06.90-03.96	F2N 770	0,8	BP7ES	2412		BPR8EIX
Clio 1	1.8	65	4	06.90-04.96	F3P710, F3P714	0,8	BP6ESZ	7639		LPG 2
Clio 1	1.8	65	4	06.96-02.98	F3P 755	0,8	BP6ESZ	7639		LPG 2
Clio 1	1.8	66	4	06.90-02.98	F3P	0,8	BP6ESZ	7639		LPG 2
Clio 1	1.8	79	4	08.95-	F3P R758	0,9	BP6ES	7811	4	LPG 2
Clio 1	1.8	81	4	02.91-04.96	F3P 712	0,8	BP6ESZ	7639		LPG 2
Clio 1.8 16V	1.8	100	4	03.91-03.96	F7P720, F7P722	0,5	BKR6EKUB	3584		LPG 1

CLIO 2

Clio 2	1.2	44	4	03.98-	D7F 720, D7F 722	0,8	BKR5EK	7956	23	LPG 1
Clio 2	1.2	44	4	10.99-	D7F 726	0,9	BKR6EZ	4619	38	LPG 1
Clio 2 16V	1.2	55	4	03.00-	D4F 712, D4F 714	0,9	LZKAR7A	6799	54	
Clio 2	1.4	55	4	03.98-03.01	E7J 780	0,9	BKR5EZ	7642	36	LPG 1
Clio 2	1.4	55	4	07.00- .03	K7J700, K7J701, K7J 710	0,9	BKR5EZ	7642	36	LPG 1
Clio 2 16V	1.4	73	4	03.98-06.00	K4J 712, K4J 713	0,9	BKR6EZ	4619	38	LPG 1
Clio 2	1.6	66	4	03.98-09.99	K7M 745	0,8	BKR5EK	7956	23	LPG 1
Clio 2 16V	1.6	66	4	03.98-09.99	K7M 744	0,8	BKR5EK	7956	23	LPG 1
Clio 2	1.6	81	4	02.99-	K4M 748	0,9	BKR6EZ	4619	38	LPG 1





l kW C
Y
I



Stock-N°

VLINE

LPG/CNG

RENAULT

CLIO 2

Clio 2 16V RS	2.0	126	4	01.00-	F4R 730	1,0	PFR6E-10	3688		
---------------	-----	-----	---	--------	---------	-----	----------	------	--	--

CLIO 2 PHASE 2

Clio 2 Phase 2	1.2	44	4	06.01-	D7FGPL	0,8	BKR5EIX	6341		LPG 1
Clio 2 Phase 2 8S	1.2	44	4	06.01-	D7F 726	0,9	BKR6EZ	4619	38	LPG 1
Clio 2 Phase 2 16S	1.2	55	4	01.02-	D4F-712	0,9	LZKAR7A	6799	54	
Clio 2 Phase 2 16S	1.4	72	4	06.01-	K4J 710, K4J 711	0,9	BKR6EZ	4619	38	LPG 1
Clio 2 Phase 2 16S	1.6	81	4	06.01-	K4M 744, K4M 745	0,9	BKR6EZ	4619	38	LPG 1
Clio 2 Phase 2 16V RS	2.0	126	4	06.01-	F4R 730	1,0	PFR6E-10	3688		

CLIO 3

Clio 3 1.2 16V	1.2	55	4	05.07-	D4F722, D4F740, D4F772	0,9	LZKAR7B	5942		
Clio 3 1.2 16V Hi-Flex	1.2	55	4	07.08-	D4F740, D4F742	0,9	LZKAR7B	5942		
Clio 3 1.2 TCe 100	1.2	74	4	05.07-	D4F780, D4F784	0,7	ILKAR7A7	91432		
Clio 3 1.4 16V	1.4	70	4	06.05-	K4J 780	0,9	BKR6EZ	4619	38	LPG 1
Clio 3 1.6 16V	1.6	81	4	06.05-	K4M800, K4M801, K4M804	0,9	BKR6EZ	4619	38	LPG 1
Clio 3 1.6 16V	1.6	94	4	11.07-	K4M 862	0,9	PFR7Z-TG	5768		
Clio 3 2.0 16V	2.0	103	4	04.06-	M4R 700	1,1	PLZKAR6A-11	5118	51	
Clio 3 2.0 16V RS	2.0	145	4	02.06-	F4R 832	0,9	PFR7Z-TG	5768		
Clio 3 2.0 16V RS	2.0	148	4	09.08-	F4R 830	0,9	PFR7Z-TG	5768		

CLIO 4

Clio 4 0.9 Tce 75	BHNP	0.9	56	3	05.18-	H4B408	0,7	ILKAR7J7G	91121		
Clio 4 0.9 TCe 90		0.9	66	3	10.12-	H4B 400	0,7	ILKAR7J7G	91121		
Clio 4 1.2 none turbo engine		1.2	54	4	10.12-	D4F 740	0,9	LZKAR7B	91432		
Clio 4 1.2 Turbo		1.2	54	4	10.12-	D4F 740	0,9	LZKAR7B	91432		
Clio 4 1.2 TCe	BHAU, KHAU	1.2	87	4	01.16-	H5F408, H5F412	0,7	ILKAR7F7G	90061		
Clio 4 1.2 TCE 120		1.2	88	4	03.13-	H5F 403	0,7	ILKAR7F7G	90061		
Clio 4 1.2 TCe	KHAU, KHM0	1.2	88	4	03.13-	H5F412	0,7	ILKAR7F7G	90061		
Clio 4 1.6 RS		1.6	147	4	03.13-	M5M 400	0,9	DILKAR7C9H	91215		
Clio 4 1.6 RS	BHJ4, DHJ6	1.6	162	4	03.15-	M5M401	0,9	DILKAR7C9H	91215		

CLIO 5

Clio 1.3 TCe 130	B7MF	1.3	96	4	06.19-	H5H450	0,7	SILZKFR8D7G	90912		
------------------	------	-----	----	---	--------	--------	-----	-------------	-------	--	--

CLIO PHASE I

Clio 1.1	B571, C571	1.1	36	4	04.92-08.92	C1E700	0,8	BP5ES	6511		LPG 2
Clio Van 1.2	S577	1.2	40	4	06.94-02.98	C3G720	0,9	BP5ESZ	4691		LPG 2
Clio 1.4	557B, B573, C573	1.4	57	4	05.90-02.98	E6J712, E6J713, E6J760	0,8	B5P5ES	7496		LPG 3
Clio 1.7	B574, C574	1.7	68	4	05.90-10.92	F2N770	0,8	BP7ES	2412		BPR8EIX
Clio 1.8	B57C, C57C	1.8	65	4	01.91-09.98	F3P710	0,8	BP6ESZ	7639		LPG 2
Clio 1.8	B57C, C57C	1.8	65	4	01.91-09.98	F3P710	0,8	BP7ES	2412		BPR8EIX
Clio 1.8	C578, C57V	1.8	66	4	08.90-09.98	F3P754	0,8	BP6ESZ	7639		LPG 2
Clio 1.8	C578, C57V	1.8	66	4	08.90-09.98	F3P754, F3P755	0,8	BP7ES	2412		BPR8EIX
Clio 1.8	B57C, C57C	1.8	70	4	01.91-09.98	F3P710	0,8	BP7ES	2412		BPR8EIX
Clio 1.8	357E, C57H	1.8	79	4	08.95-09.98	F3P758	0,8	BP6ESZ	7639		LPG 2
Clio 1.8	357E, C57H	1.8	79	4	08.95-09.98	F3P758	0,8	BP7ES	2412		BPR8EIX
Clio 1.8	C579	1.8	80	4	01.93-08.95	F3P712	0,8	BP7ES	2412		BPR8EIX
Clio 1.8	C57D	1.8	99	4	05.90-04.96	F7P722	0,9	BCPR6ET	2197		LPG 3





l kW C
Y
I



Stock-N°

VLINE

LPG/CNG

RENAULT

CLIO PHASE I

Clio 2.0 -/Williams	C57M	2.0	108	4	03.93-04.96	F7R700	0,9	BCPR6ET	2197		LPG 3
---------------------	------	-----	-----	---	-------------	--------	-----	---------	------	--	-------

CLIO PHASE II

Clio 1.0	BB0Y	1.0	40	4	02.00-05.01	D7D760	0,8	BKR5EK	7956	23	LPG 1
Clio 1.2 BiFuel	BB0F, BB1K, CB0F, CB1K	1.2	43	4	09.98-06.09	D7F744, D7F764, D7F766	0,8	BKR5EK	7956	23	LPG 1
Clio Van 1.2	SB0F	1.2	44	4	03.98-10.03	D7F746	0,8	BKR5EK	7956	23	LPG 1
Clio Thalia 1.2	LB2U, LB2V	1.2	55	4	04.02-02.09	D4F728	0,9	LZKAR7B	5942		
Clio Symbol 1.2	LB11, LB19	1.2	55	4	11.03-08.08	D4F706, D4F712	0,9	LZKAR7B	5942		
Clio Symbol 1.6	LB00	1.6	66	4	08.98-10.08	K7M746	0,8	BKR5EK	7956	23	LPG 1

CLIO PHASE III

Clio 1.2	BR01	1.2	43	4	06.06-08.10	D4F764	0,9	LZKAR7B	5942		
Clio 1.2 (For cold climate zones)	BR02, BR0J, BR11, CR02, CR0J, CR11	1.2	55	4	06.05-12.14	D4F740	0,7	ILKAR7A7	91432		
Clio Van 1.2 (For cold climate zones)	SR0J	1.2	55	4	11.05-12.14	D4F740	0,7	ILKAR7A7	91432		
Clio Van 1.2 (Not for cold climate zones)	SR0J	1.2	55	4	11.05-12.14	D4F740	0,9	LZKAR7B	5942		
Clio 1.2 Hi-Flex	BR1U, CR1U	1.2	55	4	07.08-12.12	D4F742	0,9	LZKAR7B	5942		
Clio Grandtour 1.2 Hi-Flex	KR0S	1.2	55	4	07.08-12.12	D4F744	0,9	LZKAR7B	5942		
Clio 1.2 BiFuel (For cold climate zones)	BR0J, CR0J	1.2	55	4	01.10-12.14	D4F740	0,7	ILKAR7A7	91432		
Clio 1.2	BR01	1.2	57	4	10.05-12.12	D4F764	0,9	LZKAR7B	5942		
Clio 1.2	BR01, BR03, BR0E, CR0E	1.2	58	4	06.05-12.11	D4F764	0,9	LZKAR7B	5942		
Clio Grandtour 1.2	KR0E	1.2	58	4	11.07-12.10	D4F764	0,9	LZKAR7B	5942		
Clio Grandtour 1.2 Hi-Flex	KR1U	1.2	58	4	11.07-12.12	D4F742	0,9	LZKAR7B	5942		
Clio Van 1.2 Hi-Flex	SR1U	1.2	58	4	11.07-12.09	D4F742	0,9	LZKAR7B	5942		
Clio Van 1.2 TCe	SR0P	1.2	74	4	11.07-12.11	D4F784	0,7	ILKAR7A7	91432		
Clio Grandtour 1.2	KR04	1.2	76	4	03.10-12.12	D4F786	0,7	ILKAR7A7	91432		
Clio 1.2	BR04, CR04	1.2	76	4	09.10-12.14	D4F786	0,7	ILKAR7A7	91432		

CLIO PHASE IV

Clio Grandtour 0.9 TCe	KHNP	0.9	56	3	08.18-	H4B408	0,7	ILKAR7J7G	91121		
Clio Grandtour 0.9 TCe	KHM1, KHMA	0.9	66	3	01.13-	H4B400, H4B408	0,7	ILKAR7F7G	90061		
Clio 1.2 LPG	BHMG	1.2	53	4	01.14-	D4F744	0,9	LZKAR7B	5942		
Clio Van 1.2 LPG	BHMG	1.2	53	4	01.14-	D4F744	0,9	LZKAR7B	5942		
Clio 1.2 LPG	BHMG	1.2	54	4	11.12-06.15	D4F744	0,9	LZKAR7B	5942		
Clio Van 1.2 (Not for cold climate zones)	BHA1, BHMG, BHMK	1.2	54	4	01.14-	D4F740	0,9	LZKAR7B	5942		
Clio 1.2 (Not for cold climate zones)	BHA1, BHAK, BHMG, BHMK	1.2	55	4	06.15-	D4F740	0,9	LZKAR7B	5942		
Clio Grandtour 1.2 TCe	KHAU	1.2	87	4	01.16-	H5F408, H5F412	0,7	ILKAR7F7G	90061		

DUSTER

Duster 1.6	HSA5, HSA8, HSA9, HSMR	1.6	75	4	06.11-05.15	K4M490, K4M646, K4M690	0,9	BKR6EK	2288	20	LPG 1
Duster 1.6	HSAT	1.6	75	4	06.11-05.15	K4M616	0,9	BKR6EK	2288	20	LPG 1
Duster 2.0	HSA3, HSMJ, HSMS	2.0	99	4	02.12-01.18	F4R400, F4R401, F4R402	0,9	BKR6EK	2288	20	LPG 1
Duster 2.0	HSMK, HSML	2.0	99	4	02.12-01.18	F4R403, F4R405	0,9	BKR6EK	2288	20	LPG 1
Duster 2.0	HSAA, HSAG	2.0	105	4	09.13-	F4R410, F4R412	0,9	BKR6EK	2288	20	LPG 1





l kW C
Y I



Stock-N°

VLINE

LPG/CNG

RENAULT

ESPACE 2

Espace 2	2.0		4	04.91-10.96	J7R 768 Cat	0,8	BP6EFS	3812	5	LPG 5
Espace 2	2.2	81	4	04.91-10.96	J7T 772 CAT	0,8	BP7EFS	3526		
Espace 2	2.8	113	6	04.91-10.96	Z7W712, Z7W717 Cat	0,8	BP7EFS	3526		

ESPACE 3

Espace 3	2.0	85	4	11.96-09.00	F3R728, F3R729, F3R768, F3R769	0,9	BPR5ES	7422	6	LPG 2
Espace 3	2.0	103	4	10.98-10.02	F4R700, F4R701	0,9	BKR6EZ	4619	38	LPG 1
Espace 3	2.0	103	4	09.00-	F5R	1,1	LFR4AP-11	5613		
Espace 3 V6	3.0	121	6	11.96-09.98	Z7X 775	0,5	BKR6EKUB	3584		LPG 1
Espace 3 V6 24 V	3.0	140	6	10.98-	L7X 727	1,0	PFR6E-10	3688		

ESPACE 4

Espace 4	2.0	103	4	10.02-	F4Rt	0,9	BKR6EK	2288	20	LPG 1
Espace 4 Turbo	2.0	121	4	10.02-	F4R 760	0,9	PFR6G-9	4377		PFR7G
Espace 4 Turbo	2.0	125	4	11.02-01.15	F4R794, F4R795, F4R796, F4R797, F4R896, F4R897	0,9	PFR6G-9	4377		PFR7G
Espace 4	3.5	180	6	10.02-	V4Y 711, V4Y 715	1,1	PLFR5A-11	6240		LPG 7

ESPACE 5

Espace 5 1.6 Tce (For No. OE 224011TT1C)	JRME	1.6	147	4	02.15-	M5M450	0,9	DILKAR7E9HS	95003		
--	------	-----	-----	---	--------	--------	-----	-------------	-------	--	--

ESPACE PHASE II

Espace 2.2	J63G	2.2	79	4	01.91-10.96	J7T772, J7T776	0,6	BP5EFS	3712		
Espace 2.2	J63G, J637, S637	2.2	79	4	01.91-10.96	J7T772, J7T776	0,8	BP6EFS	3812		LPG 5

ESPACE PHASE III

Espace 3.0	JE0D	3.0	123	6	11.96-10.98	Z7X775	0,9	BCPR6ET	2197		LPG 3
------------	------	-----	-----	---	-------------	--------	-----	---------	------	--	-------

ESPACE PHASE IV

Espace 2.0	JK0A, JK0N, JK1D, JK1L	2.0	125	4	03.05-01.15	F4R794, F4R795, F4R796, F4R797, F4R896, F4R897	0,9	PFR7Z-TG	5768		
------------	------------------------	-----	-----	---	-------------	--	-----	----------	------	--	--

EXPRESS 1

Express		1.0		4	03.86-08.91	C1C700, C1C706	0,9	BP5ES	6511	8	LPG 2
Express		1.1	35	4	06.87-10.97	C1E	0,9	BP5ES	6511	8	LPG 2
Express		1.4	44	4	03.86-09.91	C1J, C2J	0,9	BP5ES	6511	8	LPG 2

EXPRESS 2

Express		1.0		4	10.91-	C1C	0,9	BP5ES	6511	8	LPG 2
Express		1.2	40	4	10.91-	C3G 710	0,9	BP5ESZ	4691		LPG 2
Express		1.2		4	10.91-10.97	C1G	0,9	BP5ES	6511	8	LPG 2
Express		1.4	59	4	10.91-03.98	E7J724, E7J726, E7J773	0,9	BCP5ES	7496	16	LPG 3
Express		1.4		4	10.91-	E6J	0,9	BCP5ES	7496	16	LPG 3
Express		1.4		4	08.92-	C3J 760 Cat.	0,9	BPR5ES	7422	6	LPG 2

EXPRESS PHASE II

Express 1.1	F401	1.1	35	4	09.91-04.95	C1E762	0,8	BP5ES	6511		LPG 2
Express 1.2	F40F	1.2	40	4	09.91-04.95	C1G726	0,8	BP5ES	6511		LPG 2
Express 1.4	F40A, F40V, F40Y	1.4	43	4	09.91-08.97	E6J734, E6J738, E7J720	0,8	BCP5ES	7496		LPG 3
Express 1.4	F40U	1.4	54	4	09.91-08.93	E7J724	0,8	BCP5ES	7496		LPG 3
Express 1.4	F40U	1.4	55	4	09.91-03.98	E7J724, E7J726, E7J773	0,8	BCP5ES	7496		LPG 3
Express 1.4	F40U	1.4	58	4	01.94-03.98	E7J724	0,8	BCP5ES	7496		LPG 3





l kW C
Y
I



Stock-N°

VLINE

LPG/CNG

RENAULT

EXPRESS PHASE III

Express 1.4	F40U	1.4	59	4	07.95-08.97	E7J726, E7J773	0,8	BCP5ES	7496		LPG 3
-------------	------	-----	----	---	-------------	----------------	-----	--------	------	--	-------

EXTRA PHASE II

Extra 1.2	F40F	1.2	40	4	09.91-08.93	C1G726	0,8	BP5ES	6511		LPG 2
-----------	------	-----	----	---	-------------	--------	-----	-------	------	--	-------

Extra 1.4	F40U	1.4	58	4	01.94-03.98	E7J724, E7J726, E7J773	0,8	BCP5ES	7496		LPG 3
-----------	------	-----	----	---	-------------	------------------------	-----	--------	------	--	-------

EXTRA PHASE III

Extra 1.4	F40U	1.4	59	4	05.95-08.97	E7J726, E7J773	0,8	BCP5ES	7496		LPG 3
-----------	------	-----	----	---	-------------	----------------	-----	--------	------	--	-------

FLUENCE

Fluence 1.6 16V		1.6	81	4	02.10-	K4M838, K4M839	0,9	BKR6EZ	4619	38	LPG 1
-----------------	--	-----	----	---	--------	----------------	-----	--------	------	----	-------

Fluence 1.6 -/SCe	L304, L305, L30H, L33J	1.6	86	4	01.13-	H4M721, H4M738	1,1	PLZKAR6A-11	5118	51	
-------------------	------------------------	-----	----	---	--------	----------------	-----	-------------	------	----	--

Fluence 2.0 16V		2.0	103	4	02.10-	M4R 714, M4R 751	1,1	PLZKAR6A-11	5118	51	
-----------------	--	-----	-----	---	--------	------------------	-----	-------------	------	----	--

GRAND ESPACE PHASE IV

Grand Espace 2.0	JK0A, JK0N, JK1D, JK1L	2.0	125	4	03.05-12.15	F4R794, F4R795, F4R796, F4R797, F4R896, F4R897	0,9	PFR7Z-TG	5768		
------------------	------------------------	-----	-----	---	-------------	--	-----	----------	------	--	--

GRAND MODUS

Grand Modus 1.2 BiFuel	JP0R	1.2	55	4	05.08-12.12	D4F744	0,9	LZKAR7B	5942		
------------------------	------	-----	----	---	-------------	--------	-----	---------	------	--	--

Grand Modus 1.2	JP0S	1.2	58	4	11.07-12.13	D4F764	0,9	LZKAR7B	5942		
-----------------	------	-----	----	---	-------------	--------	-----	---------	------	--	--

Grand Modus 1.2 TCe	JP1E	1.2	76	4	11.07-12.13	D4F786	0,7	ILKAR7A7	91432		
---------------------	------	-----	----	---	-------------	--------	-----	----------	-------	--	--

KADJAR

Kadjar 1.2 TCe 130	HLMR	1.2	96	4	06.15-	H5F408	0,7	ILKAR7F7G	90061		
--------------------	------	-----	----	---	--------	--------	-----	-----------	-------	--	--

Kadjar 1.3 TCe 140	HLNB	1.3	103	4	08.18-	H5H470	0,7	SILZKFR8D7G	90912		
--------------------	------	-----	-----	---	--------	--------	-----	-------------	-------	--	--

Kadjar 1.3 TCe 160	HLNC	1.3	117	4	08.18-	H5H470	0,7	SILZKFR8D7G	90912		
--------------------	------	-----	-----	---	--------	--------	-----	-------------	-------	--	--

Kadjar 1.6 TCe 165	HLMH	1.6	120	4	11.16-	M5M460	0,9	DILKAR7E9HS	95003		
--------------------	------	-----	-----	---	--------	--------	-----	-------------	-------	--	--

KANGOO

Kangoo (XCOA)		1.2	44	4	08.97-05.00	D7F710, D7F720, D7F722, D7F726, D7F744, D7F746	0,8	BKR5EK	7956	23	LPG 1
---------------	--	-----	----	---	-------------	--	-----	--------	------	----	-------

Kangoo		1.2	44	4	05.00-	D7FGPL	0,8	BKR5EIX	6341		LPG 1
--------	--	-----	----	---	--------	--------	-----	---------	------	--	-------

Kangoo		1.2	44	4	05.00-	D7F710, D7F720, D7F722, D7F744, D7F726 Euro2000, D7F746 Euro2000	0,9	BKR6EZ	4619	38	LPG 1
--------	--	-----	----	---	--------	--	-----	--------	------	----	-------

Kangoo 16V		1.2	55	4	07.00-	D4F 712, D4F 714	0,9	LZKAR7A	5942	54	
------------	--	-----	----	---	--------	------------------	-----	---------	------	----	--

Kangoo 16V		1.2	55	4	.07-	D4F722, D4F740, D4F772	0,9	LZKAR7B	5942		
------------	--	-----	----	---	------	------------------------	-----	---------	------	--	--

Kangoo 1.2 TCe	KW02, KW14, FW02, FW14	1.2	84	4	07.13-	H5F408, H5F412	0,7	ILKAR7F7G	90061		
----------------	------------------------	-----	----	---	--------	----------------	-----	-----------	-------	--	--

Kangoo (XCOC)		1.4	55	4	10.97-03.99	E7J634, E7J635, E7J 780	0,9	BKR6EZ	4619	38	LPG 1
---------------	--	-----	----	---	-------------	-------------------------	-----	--------	------	----	-------

Kangoo		1.4	55	4	07.00-	K7J 700, K7J 701	0,9	BKR5EZ	7642	36	LPG 1
--------	--	-----	----	---	--------	------------------	-----	--------	------	----	-------

Kangoo		1.6	70	4	07.01-	K7M 746	0,8	BKR5EK	7956	23	LPG 1
--------	--	-----	----	---	--------	---------	-----	--------	------	----	-------

Kangoo 16V		1.6	70	4	07.01-	K4M708, K4M750, K4M752	0,9	BKR6EZ	4619	38	LPG 1
------------	--	-----	----	---	--------	------------------------	-----	--------	------	----	-------

KANGOO PHASE I

Kangoo Express 1.0	FC0Y	1.0	43	4	01.02-01.07	D7D700	0,8	BKR5EK	7956	23	LPG 1
--------------------	------	-----	----	---	-------------	--------	-----	--------	------	----	-------

Kangoo 1.0	KC06	1.0	50	4	01.02-01.07	D4D700, D4D720	0,9	LZKAR7B	5942		
------------	------	-----	----	---	-------------	----------------	-----	---------	------	--	--

Kangoo Express 1.0	FC06	1.0	50	4	01.02-01.07	D4D700, D4D720	0,9	LZKAR7B	5942		
--------------------	------	-----	----	---	-------------	----------------	-----	---------	------	--	--

Kangoo 1.2	KC01, KC0A, KC0F, KC0K	1.2	43	4	06.97-06.03	D7F720, D7F726, D7F746	0,8	BKR5EK	7956	23	LPG 1
------------	------------------------	-----	----	---	-------------	------------------------	-----	--------	------	----	-------

Kangoo Express 1.2 BiFuel	FC0A, FC0F	1.2	43	4	08.97-07.01	D7F710, D7F744	0,8	BKR5EK	7956	23	LPG 1
---------------------------	------------	-----	----	---	-------------	----------------	-----	--------	------	----	-------





e kW
C
Y
I



Stock-N°

VLINE

LPG/CNG

RENAULT

KANGOO PHASE I

Kangoo Express 1.2 BiFuel	FC0A, FC0F, FC1A, FC1H	1.2	44	4	08.97-06.03	D7F710, D7F722, D7F744, D7F764, D7F766	0,8	BKR5EK	7956	23	LPG 1
Kangoo Express 1.2	FC05, FC0T, FC0W, FC1D, FC1K, FC1P	1.2	55	4	07.01-06.08	D4F712, D4F714, D4F730	0,9	LZKAR7B	5942		
Kangoo Rapid 1.2	FC05, FC0W, FC1P	1.2	55	4	07.01-06.08	D4F712, D4F714, D4F730	0,9	LZKAR7B	5942		
Kangoo 1.6	KC00	1.6	66	4	09.99-06.01	K7M746	0,8	BKR5EK	7956	23	LPG 1
Kangoo Express 1.6	FC00	1.6	66	4	09.99-06.01	K7M746	0,8	BKR5EK	7956	23	LPG 1

KOLEOS

Koleos 2.0 TCe	HCM5	2.0	107	4	08.16-	M5R402	1,1	DILKAR7D11H	90565		
Koleos 2.5		2.5	125	4	06.08-	2TR700, 2TR702, 2TR703	1,1	DILKAR6A11	9029		

LAGUNA

Laguna / Nevada		1.8	66	4	01.94-12.00	F3P670, F3P676, F3P678, F3P674	0,8	BP6ESZ	7639		LPG 2
Laguna / Nevada		1.8	70	4	01.94-12.00	F3P720, F3P724	0,8	BP6ESZ	7639		LPG 2
Laguna / Nevada		1.9	103	4	03.94-12.00	N7Q 700	0,8	BKR5EK	7956	23	LPG 1
Laguna / Nevada		2.0	83	4	01.94-03.01	F3R 722, F3R 723	0,8	BP6ESZ	7639		LPG 2
Laguna / Nevada		3.0	123	6	04.94-05.96	Z7X760, Z7X765, Z7X767	0,5	BKR6EKUB	3584		LPG 1
Laguna / Nevada (Engine No 980511→)		3.0	143	6	06.96-04.98	L7X700, L7X701	1,0	PFR6E-10	3688		
Laguna / Nevada (Engine No→980511)		3.0		6	09.96-04.98	L7X700, L7X701	0,9	BKR6EKC	2848	26	LPG 1

LAGUNA 2

Laguna 2		1.6	81	4	01.01-	K4M 720	0,9	BKR6ES	3783	28	LPG 1
Laguna 2		1.6	81	4	01.01-	K4M 720	0,9	BKR6EZ	4619	38	LPG 1
Laguna 2		1.8	87	4	01.01-	F4P 760, K4M 720	0,9	BKR6ES	3783	28	LPG 1
Laguna 2 2.0 16V IDE		2.0	103	4	09.01-	F5R 700	1,1	LFR4AP-11	5613		
Laguna 2 Turbo		2.0	120	4	01.03-03.05	F4R 764, F4R 765	0,9	PFR6G-9	4377		PFR7G
Laguna 2 Turbo		2.0	121	4	.03-	F4RT 762	0,9	PFR6G-9	4377		PFR7G
Laguna 2 Turbo		2.0	125	4	03.05-12.07	F4R 786, F4R 787	0,9	PFR6G-9	4377		PFR7G
Laguna 2 Turbo		2.0	125	4	03.05-12.07	F4R 784	0,9	PFR7Z-TG	5768		
Laguna 2 Turbo		2.0	150	4	03.05-08.07	F4R 886	0,9	PFR6G-9	4377		PFR7G
Laguna 2 Turbo		2.0	150	4	03.05-08.07	F4R 887	0,9	PFR7Z-TG	5768		
Laguna 2 2.0 16V Die		2.0		4	09.01-	F5R 700	1,1	LFR4AP-11	5613		
Laguna 2		3.0	152	6	01.01-12.07	L7X 731	1,1	PLFR5A-11	6240		LPG 7

LAGUNA 3

Laguna 3 16V		1.6	85	4	02.07-	K4M	0,9	BKR6EZ	4619	38	LPG 1
Laguna 3 16V		2.0	100	4	02.07-	F4R	0,9	BKR6EZ	4619	38	LPG 1
Laguna 3		2.0	103	4	02.07-	M4R 704, M4R 726	1,1	PLZKAR6A-11	5118	51	
Laguna 3 Turbo		2.0	121	4	02.07-	F4R 762	0,9	PFR6G-9	4377		PFR7G
Laguna 3 Turbo		2.0	125	4	09.07-	F4R 811, F4R 813	0,9	PFR6G-9	4377		PFR7G
Laguna 3 2.0 GT Turbo		2.0	150	4	03.08-	F4R 800	0,9	PFR7Z-TG	5768		

LAGUNA PHASE I

Laguna 1.8	B560, B56S	1.8	70	4	04.94-06.98	F3P676, F3P676K, F3P678, F3P678K	0,8	BP6ESZ	7639		LPG 2
Laguna 2.0	B56L, B56U	2.0	80	4	07.98-02.01	F3R611	0,9	BPR5ES	7422		LPG 2
Laguna 2.0	B56C, B56H, B56N	2.0	83	4	11.93-03.01	F3R722, F3R723, F3R728, F3R729	0,9	BPR5ES	7422		LPG 2





kw
C
Y
I



Stock-N°

VLINE

LPG/CNG

RENAULT

LAGUNA PHASE I

Laguna Estate/Break 2.0	K56C, K56H, K56L, K56N	2.0	83	4	09.95-03.01	F3R611, F3R722, F3R723, F3R728, F3R729, F3R768, F3R769	0,9	BPR5ES	7422		LPG 2
Laguna 2.0	B56L, B56N	2.0	84	4	06.95-02.01	F3R728, F3R729, F3R768, F3R769	0,9	BPR5ES	7422		LPG 2
Laguna Estate/Break 2.0	K56L	2.0	84	4	10.98-01.01	F3R768	0,9	BPR5ES	7422		LPG 2

LAGUNA PHASE II

Laguna / Nevada Phase 2		1.6	81	4	04.98-12.00	K4M720, K4M724	0,8	BKR5EK	7956	23	LPG 1
Laguna / Nevada Phase 2		1.8	88	4	09.98-12.00	F4P 760	0,9	BKR6ES	3783	28	LPG 1
Laguna / Nevada Phase 2		2.0	85	4	04.98-08.98	F3R	0,9	BPR6ES	7822	2	LPG 2
Laguna / Nevada Phase 2		2.0	103	4	02.99-12.00	F4R 780	0,9	BKR6ES	3783	28	LPG 1
Laguna / Nevada Phase 2		3.0	143	6	05.98-12.00	L7X700, L7X701	1,0	PFR6E-10	3688		

LOGAN

Logan 1.2 LPG	L8MG, L8MP	1.2	53	4	11.13-	D4F732, D4F734	0,9	LZKAR7B	5942		
Logan MCV 1.2 LPG	K8MG, K8MP	1.2	53	4	12.13-	D4F732, D4F734	0,9	LZKAR7B	5942		
Logan 1.2	L8MG, L8MP	1.2	54	4	11.13-	D4F732, D4F734	0,9	LZKAR7B	5942		
Logan MCV 1.2	K8MG, K8MP	1.2	54	4	12.13-	D4F732, D4F734	0,9	LZKAR7B	5942		
Logan 1.4 LPG	LS0C, LS0E	1.4	53	4	02.08-10.13	K7J714	0,9	BKR6EK	2288	20	LPG 1
Logan 1.4	LS0A, LS0C, LS0E	1.4	55	4	08.04-06.15	K7J710	0,9	BKR6EK	2288	20	LPG 1
Logan MCV 1.4	KS0A	1.4	55	4	10.07-11.12	K7J710	0,9	BKR6EK	2288	20	LPG 1
Logan 1.6	L8JB, L8ME, L8MV	1.6	59	4	11.13-	K7M812	0,9	BKR6EK	2288	20	LPG 1
Logan MCV 1.6	K8JB	1.6	59	4	12.13-	K7M812	0,9	BKR6EK	2288	20	LPG 1
Logan 1.6	L8JB, L8ME, L8MV	1.6	60	4	04.14-	K7M812	0,9	BKR6EK	2288	20	LPG 1
Logan Stepway 1.6	L8JB, L8ME, L8MV	1.6	60	4	09.18-	K7M812	0,9	BKR6EK	2288	20	LPG 1
Logan 1.6	LS0B, LS0D	1.6	64	4	09.04-10.13	K7M710	0,8	BKR5EK	7956	23	LPG 1
Logan 1.6	LS0B, LS0D	1.6	64	4	09.04-10.13	K7M710	0,9	BKR6EK	2288	20	LPG 1
Logan 1.6	FS0B, FS0D, FS0F, FS11, FS1E	1.6	64	4	04.07-08.12	K7M710	0,8	BKR5EK	7956	23	LPG 1
Logan MCV 1.6	KS0B	1.6	64	4	04.07-11.12	K7M710	0,8	BKR5EK	7956	23	LPG 1
Logan 1.6	FS0B, FS0D, FS0F, FS11, FS1E	1.6	64	4	04.07-08.12	K7M710	0,9	BKR6EK	2288	20	LPG 1
Logan MCV 1.6	KS0B	1.6	64	4	04.07-11.12	K7M710	0,9	BKR6EK	2288	20	LPG 1
Logan 1.6	L8A9, L8JO, L8JD, L8M9, L8MT	1.6	75	4	04.14-	K4M842, K4M845	0,9	BKR6EK	2288	20	LPG 1
Logan Stepway 1.6	L8A9, L8JO	1.6	75	4	04.14-	K4M845	0,9	BKR6EK	2288	20	LPG 1
Logan 1.6	LS09, LS0L, LS0M, LS0P, LS0V, LS1S, LS1V, LS1Y	1.6	77	4	04.07-10.13	K4M690, K4M694, K4M696, K4M697	0,9	BKR6EK	2288	20	LPG 1
Logan MCV 1.6	KS0L, KS0M, KS0P, KS1S	1.6	77	4	04.07-11.12	K4M690, K4M696, K4M697	0,9	BKR6EK	2288	20	LPG 1

MEGANE

Megane / Classic		1.4	51	4	10.95-03.99	E7J 624	0,9	BCP5ES	7496	16	LPG 3
Megane / Classic		1.4	55	4	10.95-03.99	E7J 764	0,9	BCP5ES	7496	16	LPG 3
Megane / Classic		1.6	66	4	10.95-10.98	K7M702, K7M703, K7M720	0,9	BCPR5ES	6130	32	LPG 3
Megane Coupe / cabrio		1.6	66	4	10.95-10.98	K7M702, K7M703	0,9	BCPR5ES	6130	32	LPG 3
Megane / Classic GPL		1.6	66	4	07.97-04.99	K7M 702	0,8	BKR5EIX	6341		LPG 1





l kW C
Y I



Stock-N°

VLINE

LPG/CNG

RENAULT

MEGANE

Megane / Classic	1.6	66	4	10.98-04.99	K7M 720	0,9	BKR5EZ	7642	36	LPG 1
Megane Coupe / cabrio	1.6	66	4	10.98-03.99	K7M702, K7M703	0,9	BKR5EZ	7642	36	LPG 1
Megane	1.8	88	4	10.00-09.03	F4P720, F4P722	1,1	BKR6E-11	2756	14	LPG 1
Megane / Classic	2.0	85	4	10.95-03.99	F3R750, F3R751, F3R791, F3R796, F3R797, F3R798	0,9	BPR5ES	7422	6	LPG 2
Megane Coupe / cabrio	2.0	85	4	10.95-03.99	F3R750, F3R751, F3R791, F3R796, F3R797, F3R798	0,9	BPR5ES	7422	6	LPG 2
Megane / Classic	2.0	110	4	10.95-03.99	F7R 710, F7R 714	0,5	BKR6EKUB	3584		LPG 1
Megane Coupe / cabrio	2.0	110	4	10.95-03.99	F7R710, F7R714	0,5	BKR6EKUB	3584		LPG 1

MEGANE 2

Megane 2	1.4	70	4	.03-	K4J 730	0,9	BKR6EZ	4619	38	LPG 1
Megane 2 Coupe / cab 16 V	1.4	72	4	.03-	K4J	0,9	BKR6EZ	4619	38	LPG 1
Megane 2 1.6 Flex Fuel	1.6	77	4	02.08-07.09	K4M	0,9	BKR6EZ	4619	38	LPG 1
Megane 2	1.6	85	4	.03-	K4M 760	0,9	BKR6EZ	4619	38	LPG 1
Megane 2 Coupe / cab 16V	1.6	85	4	.03-	K4M	0,9	BKR6EZ	4619	38	LPG 1
Megane 2	2.0	100	4	.03-	F4R	0,9	BKR6EZ	4619	38	LPG 1
Megane 2 Coupe / cab	2.0	100	4	.03-	F4R	0,9	BKR6EZ	4619	38	LPG 1
Megane 2	2.0	121	4	.05-	F4R 762, F4R 776	0,9	PFR6G-9	4377		PFR7G
Megane 2 2.0 Renault Sport	2.0	165	4	05.04-10.09	F4R 774	0,9	PFR7Z-TG	5768		
Megane 2 2.0 Renault Sport	2.0	169	4	08.06-02.08	F4R 774	0,9	PFR7Z-TG	5768		

MEGANE 3

Megane 3 1.2 TCe 115	1.2	85	4	03.12-	H5F 400	0,7	ILKAR7F7G	90061		
Megane 3 1.2 TCe	BZ11, BZ2B, DZ11, DZ2B, KZ11, KZ2B	1.2	85	4	03.12-08.15	H5F408	0,7	ILKAR7F7G	90061	
Megane 3 1.4 TCe 130	1.4	96	4	06.09-	H4J 700	0,7	ILKAR7A7	91432		
Megane 3 1.6 16V	1.6	74	4	11.08-	K4M 812, K4M 848	0,9	BKR6EZ	4619	38	LPG 1
Megane 3 1.6 16V	1.6	81	4	11.08-	K4M 858	0,9	BKR6EZ	4619	38	LPG 1
Megane 3 2.0 CVT	2.0	103	4	02.09-	M4R 711, M4R 713	1,1	PLZKAR6A-11	5118	51	
Megane 3 2.0 Tce 180	2.0	132	4	11.08-	F4R 870, F4R 872	0,9	PFR6G-9	4377		PFR7G
Megane 3 RS	2.0	184	4	11.09-	F4R 874	0,8	IFR7X8G	95820		

MEGANE 4

Megane 4 1.2 TCe	B9MS, K9MS	1.2	74	4	11.15-	H5F408	0,7	ILKAR7F7G	90061	
Megane 4 1.2 TCe	B9MR, LVMR, K9MR	1.2	97	4	11.15-	H5F408	0,7	ILKAR7F7G	90061	
Megane 1.3 TCe	B9N8, K9N8	1.3	75	4	08.18-	H5H470	0,7	SILZKFR8D7G	90912	
Megane 1.3 TCe	B9N9, LVN9, K9N9	1.3	85	4	01.18-	H5H450, H5H470	0,7	SILZKFR8D7G	90912	
Megane 1.3 TCe	LVN9, LVNB, K9NB, B9NB	1.3	103	4	01.18-	H5H450, H5H470	0,7	SILZKFR8D7G	90912	
Megane 1.3 TCe	K9NC, B9NC	1.3	117	4	07.18-	H5H470	0,7	SILZKFR8D7G	90912	
Megane 1.3 TCe	B9NC, K9NC	1.3	120	4	01.18-	H5H450	0,7	SILZKFR8D7G	90912	
Megane 1.3 TCe	K9NC, B9NC	1.3	120	4	01.18-	H5H470	0,7	SILZKFR8D7G	90912	
Megane IV 1.6 Sce	B9M0	1.6	84	4	11.15-	H4M738	0,9	LZKAR7D-9D	94951	
Megane 4 1.6 TCe	B9MF, K9MF	1.6	121	4	07.17-	M5M450	0,9	DILKAR7E9HS	95003	
Megane 4 1.6 Tce	B9MV, K9MV	1.6	151	4	11.15-	M5M450	0,9	DILKAR7E9HS	95003	

MEGANE PHASE I

Megane 1.4	BA0T	1.4	52	4	08.95-02.99	E7J624	0,8	BCP5ES	7496		LPG 3
------------	------	-----	----	---	-------------	--------	-----	--------	------	--	-------





l kW C
Y
I



Stock-N°

VLINE

LPG/CNG

RENAULT

MEGANE PHASE I

Megane 1.6	BA0L, BA0S	1.6	55	4	08.95-02.99	K7M720, K7M790	0,8	BKR5EK	7956	23	LPG 1
Megane Classic 1.6	LA0L, LA0S	1.6	55	4	08.95-03.99	K7M720, K7M790	0,8	BKR5EK	7956	23	LPG 1
Megane Classic 1.6	LA1C	1.6	64	4	02.00-09.00	K7M704	0,8	BKR5EK	7956	23	LPG 1
Megane 1.6 BiFuel	BA0F, BA0S	1.6	66	4	08.95-03.99	K7M702	0,8	BKR5EK	7956	23	LPG 1
Megane 1.6	BA0F	1.6	66	4	08.95-03.99	K7M703	0,8	BKR5EK	7956	23	LPG 1
Megane Coupe 1.6	DA0F	1.6	66	4	08.95-02.99	K7M702, K7M703	0,8	BKR5EK	7956	23	LPG 1
Megane Classic 1.6	LA0F, LA0S	1.6	66	4	10.96-12.99	K7M702, K7M703	0,8	BKR5EK	7956	23	LPG 1
Megane Cabrio 1.6	EA0F	1.6	66	4	02.97-02.99	K7M702	0,8	BKR5EK	7956	23	LPG 1
Megane Estate/Break 1.6	KA0F	1.6	66	4	03.99-12.03	K7M702	0,8	BKR5EK	7956	23	LPG 1
Megane Coupe 2.0	DA0G	2.0	80	4	03.99-08.03	F3R791, F3R796	0,9	BPR5ES	7422		LPG 2
Megane 2.0	BA07, BA0G	2.0	84	4	01.96-08.03	F3R791, F3R796, F3R797, F3R798	0,9	BPR5ES	7422		LPG 2
Megane Classic 2.0	LA0G	2.0	84	4	09.96-08.03	F3R750	0,9	BPR5ES	7422		LPG 2
Megane Coupe 2.0	DA0H	2.0	108	4	03.96-11.99	F7R710, F7R714	0,9	BCPR6ET	2197		LPG 3
Megane 2.0	BA0H	2.0	108	4	07.96-01.99	F7R710, F7R714	0,9	BCPR6ET	2197		LPG 3
Megane Cabrio 2.0	EA0H	2.0	108	4	10.96-11.99	F7R710, F7R714	0,9	BCPR6ET	2197		LPG 3

MEGANE PHASE II

Megane / Classic Phase 2		1.4	55	4	04.99-	E7J 626	0,9	BKR6ES	3783	28	LPG 1
Megane / Classic Phase 2		1.4	70	4	09.99-	K4J 750	0,9	BKR6EZ	4619	38	LPG 1
Megane Coupe / cab. phase 2		1.4	70	4	09.99-	K4J 750	0,9	BKR6EZ	4619	38	LPG 1
Megane / Classic Phase 2		1.6	66	4	04.99-	K7M 704	0,8	BKR5EK	7956	23	LPG 1
Megane / Classic Phase 2		1.6	81	4	04.99-	K4M700, K4M701, K4M704, K4M706	0,9	BKR6EZ	4619	38	LPG 1
Megane Coupe / cab. phase 2		1.6	81	4	04.99-	K4M700, K4M701	0,9	BKR6EZ	4619	38	LPG 1
Megane Coupe / cab. phase 2		1.8	87	4	05.01-	F4P 760	0,9	BKR6ES	3783	28	LPG 1
Megane IDE Coupe Cab. Phase 2 2.0 16V Ide		2.0	103	4	11.99-	F5R 740	1,1	LFR4AP-11	5412		
Megane Coupe / cab. phase 2		2.0	103	4	06.03-	F5R 740	1,1	LFR4AP-11	5613		
Megane 2.0	BM0M, BM11, CM0M, CM11, CM1L	2.0	165	4	05.04-10.09	F4R774	0,9	PFR7Z-TG	5768		
Megane 2.0	BM1V, CM1V, CM2H, CM2J	2.0	169	4	08.06-02.08	F4R774	0,9	PFR7G-9	4371		

MEGANE PHASE III

Megane 2.0	BZ1E, BZ1P	2.0	105	4	01.11-08.15	M4R710, M4R713	1,1	PLZKAR6A-11	5118	51	
Megane 2.0 TCe	BZ20	2.0	140	4	01.13-08.15	F4R872	0,9	PFR6G-9	4377		PFR7G
Megane Coupe 2.0 TCe	DZ20	2.0	140	4	01.13-08.15	F4R872	0,9	PFR6G-9	4377		PFR7G
Megane Estate/Break 2.0 TCe	KZ20	2.0	140	4	01.13-08.15	F4R872	0,9	PFR6G-9	4377		PFR7G
Megane Coupe 2.0 TCe	DZ0T, DZ17, DZ18, DZ21	2.0	195	4	10.11-	F4R874	0,8	IFR7X8G	95820		
Megane Coupe 2.0 TCe	DZ0T, DZ15, DZ17, DZ18, DZ1N, DZ21	2.0	201	4	07.14-	F4R874	0,8	IFR7X8G	95820		

MEGANE RS

Megane RS		2.0	147	4	.06-	F4R 830	0,9	PFR7Z-TG	5768		
Megane RS		2.0	165	4	03.04- .07	F4RT 774	0,9	PFR7G-9	4371		
Megane RS		2.0	169	4	.07-	F4RT 774	0,9	PFR7Z-TG	5768		

MODUS

Modus 16 V		1.2	55	4	09.04-05.07	D4F	0,9	LZKAR7A	6799	54	
------------	--	-----	----	---	-------------	-----	-----	---------	------	----	--





l kW C
Y I



Stock-N°

VLINE

LPG/CNG

RENAULT

MODUS

Modus	1,2	55	4	06.07-	D4F722, D4F740, D4F772, D4F 740	0,9	LZKAR7B	5942		
Modus 1.2 BiFuel JP0R	1,2	55	4	05.08-12.12	D4F744	0,9	LZKAR7B	5942		
Modus 1.2 JP0S	1,2	58	4	04.05-12.13	D4F764	0,9	LZKAR7B	5942		
Modus TCe 100	1,2	74	4	05.07-	D4F780, D4F784	0,7	ILKAR7A7	91432		
Modus 1.2 TCe JP1E	1,2	76	4	04.11-12.13	D4F786	0,7	ILKAR7A7	91432		
Modus 16 V	1,4	72	4	09.04-	K4M	0,9	BKR6EZ	4619	38	LPG 1
Modus 1.6	1,6	65	4	12.04-	K4M792, K4M794	0,9	BKR6EZ	4619	38	LPG 1
Modus 1.6	1,6	82	4	09.04-	K4J	0,9	BKR6EZ	4619	38	LPG 1

R 19

R 19	1,2	40	4	09.88-12.92	C1G 730	0,9	BP5ESZ	4691		LPG 2
R 19	1,4	43	4	09.88-03.92	C1J 742, C2J 772	0,9	BP5ESZ	4691		LPG 2
R 19	1,4	50	4	09.88-03.96	C2J 776	0,9	BP5ES	6511	8	LPG 2
R 19	1,4	59	4	09.88-03.92	E6J...,E7J... Cat.	0,9	BCP5ES	7496	16	LPG 3
R 19	1,7	54	4	03.86-	F3N-740, F3N-741	0,9	BPR6ES	7822	2	LPG 2
R 19	1,7	55	4	09.88-03.96	F2N-724	0,8	BP7ES	2412		BPR8EIX
R 19	1,7	66	4	09.88-03.92	F3N-742, F3N-743	0,8	BP7ES	2412		BPR8EIX
R 19	1,7	66	4	09.88-03.92	F3N 746	0,9	BPR6ES	7822	2	LPG 2
R 19	1,7	68	4	09.88-03.96	F2N720, F2N721	0,8	BP7ES	2412		BPR8EIX
R 19	1,8	54	4	.94-	F3N 740, F3N 741	0,9	BPR6ES	7822	2	LPG 2
R 19	1,8	81	4	06.89-03.92	F7P 700 Cat.	0,5	BKR6EKUB	3584		LPG 1
R 19 16V	1,8		4	06.89-03.96	F7P 704 Cat.	0,9	BCP6ES	4930	17	LPG 3

R 19 PHASE 2

R 19 Phase 2	1,2	40	4	04.92-12.95	C1G 730	0,9	BP5ESZ	4691		LPG 2
R 19 Phase 2	1,2	45	4	04.92-12.95	E7F 730	0,9	BCP5ES	7496	16	LPG 3
R 19 Phase 2	1,4	44	4	04.92-12.95	C3J 710	0,9	BPR5ES	7422	6	LPG 2
R 19 Phase 2	1,4	55	4	04.92-12.95	E7J 706, E7J 745	0,9	BCP5ES	7496	16	LPG 3
R 19 Phase 2	1,4		4	04.92-12.95	E6J700	0,9	BCP5ES	7496	16	LPG 3
R 19 Phase 2	1,4		4	04.92-12.95	C1J	0,9	BP5ESZ	4691		LPG 2
R 19 Phase 2	1,8	70	4	04.92-12.95	F3P 704, F3P 706	0,9	BP6ES	7811	4	LPG 2
R 19 Phase 2	1,8	99	4	04.92-12.95	F7P 704	0,5	BKR6EKUB	3584		LPG 1
R 19 Phase 2	1,8		4	04.92-12.95	F3P 705, F3P 707	0,9	BP6ES	7811	4	LPG 2
R 19 Phase 2	1,8		4	04.92-12.95	F7P 700	0,8	BP6ESZ	7639		LPG 2

R 21

R 21	1,4	51	4	09.89-10.93	C2J	0,9	BP6ES	7811	4	LPG 2
R 21 Nevada	1,7	65	4	03.86-12.95	F2N 711	0,8	BP7ES	2412		BPR8EIX
R 21 Nevada	1,7	65	4	02.88-12.95	F2N 754	0,8	BP7ES	2412		BPR8EIX
R 21 Nevada	1,7		4	09.89-12.95	F3N722, F3N723	0,8	BP7ES	2412		BPR8EIX
R 21	1,7		4	09.89-12.95	F3N 726	0,9	BPR6ES	7822	2	LPG 2
R 21	2,0	66	4	08.86-12.95	F2R 702	0,8	BP7ES	2412		BPR8EIX
R 21	2,0	76	4	03.86-12.95	J6R	0,8	BP6EFS	3812	5	LPG 5
R 21 Nevada	2,0	85	4	-12.92	J7R750, J7R751	0,8	BP7EFS	3526		
R 21 Nevada	2,0	98	4	05.89-12.95	J7R 754	0,9	BCP6ET	4563		LPG 3
R 21	2,0	99	4	06.90-12.93	J7R746, J7R747	0,8	BP6EFS	3812	5	LPG 5
R 21 Nevada	2,0	110	4	09.89-12.95	J7R 740	0,9	BCP6ET	4563		LPG 3
R 21 Nevada Turbo	2,0	119	4	08.89-10.93	J7R 752	1,0	TR7IX	3690		





l kW C
Y
I



Stock-N°

VLINE

LPG/CNG

RENAULT

R 21

R 21 Nevada Turbo	2.0	119	4	01.93-	J7R 756	1,0	TR7IX	3690		
R 21 Nevada	2.2	79	4	01.93-	J7T754, J7T755	0,8	BP7EFS	3526		

R 25

R 25	2.0	74	4	01.84-12.92	J6R706, J6R707, J6R762, J6R763	0,8	BP6EFS	3812	5	LPG 5
R 25	2.0	88	4	06.87-12.92	J7R722, J7R723	0,8	BP7EFS	3526		
R 25	2.0	103	4	10.88-12.92	J7R720, J7R721, J7R726	0,9	BCP6ET	4563		LPG 3
R 25	2.2	79	4	10.86-12.92	J7T706, J7T707, J7T730, J7T731, J7T732, J7T733	0,8	BP7EFS	3526		
R 25 V6 Turbo	2.5	147	6	05.89-12.92	Z7U700 Cat.	1,0	TR7IX	3690		
R 25 V6	2.8	110	6	06.87-12.92	Z7W700, Z7W701, Z7W706, Z7W707 Cat.	0,8	BP7EFS	3526		

R 5

R 5	1.4	43	4	10.84-12.96	C1J 768	0,9	BP6ES	7811	4	LPG 2
R 5	1.4	44	4	10.84-12.96	C3J700, C3J702, C3J760	0,9	BPR5ES	7422	6	LPG 2
R 5	1.4	44	4	06.87-12.96	C2J 784	0,9	BP6ES	7811	4	LPG 2
R 5	1.4	49	4	10.84-12.96	C2J780, C2J781, C2J782, C2J788, C2J789, C2J798	0,9	BP6ES	7811	4	LPG 2
R 5	1.4	50	4	06.87-12.96	C2J 700	0,9	BP6ES	7811	4	LPG 2
R 5	1.7	55	4	10.86-12.96	F3N716, F3N717	0,9	BPR6ES	7822	2	LPG 2
R 5	1.7	66	4	06.87-12.96	F2N740, F2N742	0,9	BP6ES	7811	4	LPG 2
R 5	1.7	69	4	10.86-12.96	F3N 702	0,8	BP7ES	2412		BPR8EIX

RAPID

Rapid	F40U	1.4	54	4	09.91-08.93	E7J724	0,9	BCP5ES	7496	16	LPG 3
Rapid	F40U	1.4	58	4	01.94-03.98	E7J724, E7J772, E7J773	0,9	BCP5ES	7496	16	LPG 3
Rapid	F40U	1.4	59	4	07.95-08.97	E7J726, E7J773	0,9	BCP5ES	7496	16	LPG 3
Rapid	F40E, F40P	1.9	47	4	07.95-03.98	F8Q776	0,9	BCP5ES	7496	16	LPG 3
Rapid 1.1	F401	1.1	35	4	09.91-04.95	C1E762	0,8	BP5ES	6511		LPG 2
Rapid 1.2	F40F	1.2	40	4	09.91-08.93	C1G726	0,8	BP5ES	6511		LPG 2
Rapid 1.4	F40U	1.4	54	4	09.91-08.93	E7J724	0,8	BCP5ES	7496		LPG 3
Rapid 1.4	F40U	1.4	58	4	01.94-03.98	E7J724, E7J772, E7J773	0,8	BCP5ES	7496		LPG 3
Rapid 1.4	F40U	1.4	59	4	07.95-08.97	E7J726, E7J773	0,8	BCP5ES	7496		LPG 3

SAFRANE

Safrane		1.9		4	06.92-09.96	N7Q 710, N7Q 711	0,5	BKR6EKUB	3584		LPG 1
Safrane		2.0	77	4	06.92-09.96	J7R723, J7R733	0,8	BP6EFS	3812	5	LPG 5
Safrane		2.0	97	4	04.92-09.96	J7R734, J7R735, J7R738, J7R739	0,9	BCP6ET	4563		LPG 3
Safrane		2.2	103	4	06.92-09.96	J7T760, J7T761	0,9	BCP6ET	4563		LPG 3
Safrane		2.2		4	06.92-09.96	J7T 762	0,8	BP6EFS	3812	5	LPG 5
Safrane V6		3.0	123	6	10.96-	Z7X W755	0,9	BKR6EK	2288	20	LPG 1
Safrane	B54M	3.0	123	6	11.96-04.00	Z7X755	0,5	BKR6EKUB	3584		LPG 1
Safrane V6		3.0	125	6	06.92-09.96	Z7X721, Z7X722, Z7X723, Z7X753, Z7X755	0,5	BKR6EKUB	3584		LPG 1
Safrane Biturbo		3.0	194	6	.94-09.96	Z7X 726	0,8	BKUR7ET	7873		

SAFRANE PHASE I

Safrane 2.0	B540	2.0	77	4	01.92-10.96	J7R732, J7R733	0,6	BP5EFS	3712		
-------------	------	-----	----	---	-------------	----------------	-----	--------	------	--	--





l kW C
Y
I



Stock-N°

VLINE

LPG/CNG

RENAULT

SAFRANE PHASE I

Safrane 2.2	B541	2.2	79	4	04.92-07.96	J7T762	0,6	BP5EFS	3712		
Safrane 3.0	B545	3.0	193	6	01.92-10.96	Z7X726	0,9	BCP7ET	2078		

SAFRANE PHASE II

Safrane Phase 2		1.9	100	4	10.96-12.00	N7Q710, N7Q711	0,8	BKR5EK	7956	23	LPG 1
Safrane Phase 2		2.5	121	6	10.96-12.00	N7U700, N7U701	0,9	BCPR6ES	2330	12	LPG 3
Safrane Phase 2 V6		3.0	125	6	10.96-03.99	Z7X721, Z7X722, Z7X723, Z7X753, Z7X755	0,5	BKR6EKUB	3584		LPG 1
Safrane Phase 2 V6		3.0	143	6	04.99-12.00	L7X 713	1,0	PFR6E-10	3688		
Safrane 2.0	B54L	2.0	100	4	11.96-12.00	N7Q710, N7Q711	0,9	BCPR6ET	2197		LPG 3
Safrane 2.5	B54F	2.5	121	5	07.96-12.00	N7U700, N7U701	0,9	BKR6ES	3783		LPG 1

SANDERO

Sandero 0.9 TCe	B8MA	0.9	66	3	03.14-	H4B400	0,7	ILKAR7F7G	90061		
Sandero Stepway 0.9 TCe	B8MA	0.9	66	3	03.14-	H4B400	0,7	ILKAR7F7G	90061		
Sandero 0.9 TCe	B8MA	0.9	66	3	03.14-	H4B400	0,7	ILKAR7J7G	91121		
Sandero Stepway 0.9 TCe	B8MA	0.9	66	3	03.14-	H4B400	0,7	ILKAR7J7G	91121		
Sandero 1.2 LPG	B8MG, B8MP	1.2	53	4	12.13-	D4F734	0,9	LZKAR7B	5942		
Sandero 1.2	B8MG, B8MP, B8MY	1.2	54	4	12.13-	D4F732, D4F734	0,9	LZKAR7B	5942		
Sandero 1.2	B8MG	1.2	55	4	04.15-	D4F732	0,9	LZKAR7B	5942		
Sandero 1.6	B8JB, B8ME, B8MV	1.6	59	4	11.13-	K7M812	0,9	BKR6EK	2288	20	LPG 1
Sandero Stepway 1.6	B8JB, B8ME, B8MV	1.6	59	4	11.13-	K7M812	0,9	BKR6EK	2288	20	LPG 1
Sandero 1.6	BS0H	1.6	62	4	11.10-07.13	K7M710	0,9	BKR6EK	2288	20	LPG 1
Sandero 1.6	BS0H	1.6	64	4	02.09-	K7M710	0,8	BKR5EK	7956	23	LPG 1
Sandero 1.6	BS0H	1.6	64	4	02.09-	K7M710	0,9	BKR6EK	2288	20	LPG 1
Sandero 1.6	BS1E	1.6	75	4	12.07-07.13	K7M710	0,8	BKR5EK	7956	23	LPG 1
Sandero 1.6	BS1E	1.6	75	4	12.07-07.13	K7M710	0,9	BKR6EK	2288	20	LPG 1
Sandero 1.6	BS1P	1.6	76	4	12.07-07.13	K4M697	0,9	BKR6EK	2288	20	LPG 1
Sandero 1.6	BS1P	1.6	77	4	12.12-	K4M697	0,9	BKR6EK	2288	20	LPG 1

SCENIC

Scenic		1.4	55	4	10.95-03.99	E7J 764	0,9	BCP5ES	7496	16	LPG 3
Scenic		1.6	66	4	10.95-09.98	K7M 702,703,720	0,9	BCPR5ES	6130	32	LPG 3
Scenic GPL		1.6	66	4	07.97-03.99	K7M 702	0,8	BKR5EK	7956	23	LPG 1
Scenic		1.6	66	4	10.98-03.99	K7M 702,703,720	0,9	BKR5EZ	7642	36	LPG 1
Scenic		2.0	85	4	10.95-03.99	F3R750, F3R751, F3R791, F3R796, F3R797, F3R798	0,9	BPR5ES	7422	6	LPG 2
Scenic	JZ0G, JZ0P, JZ1E, JZ1P	2.0	103	4	12.08-	M4R711	1,1	PLZKAR6A-11	5118	51	

SCENIC 2

Scenic 2 & Break		1.4	72	4	.03-	K4J	0,9	BKR6EZ	4619	38	LPG 1
Scenic 2 & Break		1.6	85	4	.03-	K4M	0,9	BKR6EZ	4619	38	LPG 1
Scenic 2 & Break		2.0	100	4	.03-	F4R	0,9	BKR6EZ	4619	38	LPG 1

SCENIC 3

Scenic 3 1.2 TCe	JZ11, JZ28	1.2	85	4	03.12-	H5F408	0,7	ILKAR7F7G	90061		
Scenic 3 1.2 TCe 115		1.2	85	4	04.12-	H5F 400	0,7	ILKAR7F7G	90061		
Scenic 3 1.2 TCe	JZ28	1.2	96	4	07.14-	H5F408	0,7	ILKAR7F7G	90061		
Scenic 3 1.2 TCe	JZ16, JZ28	1.2	97	4	01.13-	H5F408	0,7	ILKAR7F7G	90061		





l kW C
Y
I



Stock-N°

VLINE

LPG/CNG

RENAULT

SCENIC 3

Scenic 3 1.2 TCe 130	1.2	97	4	06.13-	H5F 404	0,7	ILKAR7F7G	90061		
Scenic 3 1.4 TCe 130	1.4	96	4	02.09-	H4J 700	0,7	ILKAR7A7	91432		
Scenic 3 2.0 16V	2.0	103	4	02.09-	M4R 710	1,1	PLZKAR6A-11	5118	51	

SCENIC 4

Scenic 4 1.2 TCe	R9MB, J9MB	1.2	85	4	09.16-	H5F408	0,7	ILKAR7F7G	90061		
Scenic 4 1.2 TCe	R9MR, J9MR	1.2	96	4	09.16-	H5F408	0,7	ILKAR7F7G	90061		
Scenic 1.3 TCe	J9N9, R9N9	1.3	85	4	01.18-	H5H450, H5H470	0,7	SILZKFR8D7G	90912		
Scenic 1.3 TCe	J9NB, R9NB	1.3	103	4	01.18-	H5H450, H5H470	0,7	SILZKFR8D7G	90912		
Scenic 1.3 TCe	J9NC, R9NC	1.3	117	4	09.18-	H5H470	0,7	SILZKFR8D7G	90912		
Scenic 1.3 TCe	J9NC, R9NC	1.3	120	4	01.18-	H5H450	0,7	SILZKFR8D7G	90912		

SCENIC PHASE II

Scenic Phase 2		1.4	70	4	09.99-	K4J 750	0,9	BKR6EZ	4619	38	LPG 1
Scenic Phase 2		1.6	81	4	09.99-	K4M 708, K4M 709	0,9	BKR6EZ	4619	38	LPG 1
Scenic Phase 2		1.8	87	4	07.00-	F4P 760	0,9	BKR6ES	3783	28	LPG 1
Scenic Phase 2		2.0	103	4	08.99-	F4R740, F4R741	0,9	BKR6ES	3783	28	LPG 1
Scenic Phase 2		2.0	103	4	03.00-	F4R 744	0,9	BKR6ES	3783	28	LPG 1
Scenic Phase 2		2.0	120	4	03.04-11.08	F4R 776	0,9	PFR6G-9	4377		PFR7G

SCENIC PHASE III

Scenic 1.2 TCe	JZ16, JZ28	1.2	97	4	01.13-	H5F404, H5F408	0,7	ILKAR7F7G	90061		
Scenic 1.4 TCe	JZ0F, JZ1V	1.4	96	4	02.09-	H4J700	0,7	ILKAR7F7G	90061		

SPORT SPIDER

Sport Spider		2.0	110	4	03.95-	F7R710, F7R712, F7R720	0,5	BKR6EKUB	3584		LPG 1
--------------	--	-----	-----	---	--------	------------------------	-----	----------	------	--	-------

SYMBOL

Symbol 1.2 16V (LB0/1/2)	LB0, 1, 2	1.2	55	4	04.02-	D4F 712	0,9	LZKAR7A	6799	54	
Symbol 1.2 LPG	LU2V	1.2	55	4	01.10-12.13	D4F728	0,9	LZKAR7B	5942		
Symbol 1.4 (LB0/1/2)	LB0, 1, 2	1.4	55	4	08.00-10.05	K7J 700	0,9	BKR5EZ	7642	36	LPG 1
Symbol 1.4 16V (LB0/1/2)	LB0, 1, 2	1.4	72	4	08.00-	K4J 712	0,9	BKR6EZ	4619	38	LPG 1
Symbol 1.6 16V (LB0/1/2)	LB0, 1, 2	1.6	79	4	04.02-10.05	K4M734, K4M740, K4M745	0,9	BKR6EZ	4619	38	LPG 1

SYMBOL II

Symbol II 1.2 16V	LU1, 2	1.2	55	4	09.08-	D4F 712	0,9	LZKAR7A	6799	54	
Symbol II 1.6 16V	LU1, 2	1.6	77	4	09.08-	K4M 745	0,9	BKR6EZ	4619	38	LPG 1

TALISMAN

Talisman 1.3 TCe	LPNC, KPNC	1.3	117	4	01.19-	H5H470	0,7	SILZKFR8D7G	90912		
Talisman 1.6 TCe	LPMJ, KPMJ	1.6	110	4	11.15-	M5M450	0,9	DILKAR7E9HS	95003		
Talisman 1.6 TCe	LPMV, KPMV	1.6	147	4	11.15-	M5M450	0,9	DILKAR7E9HS	95003		

THALIA

Thalia 1.2 16V (LB0/1/2)	LB0, 1, 2	1.2	55	4	04.02-	D4F 712	0,9	LZKAR7A	6799	54	
Thalia 1.2 16V	LU1, 2	1.2	55	4	09.08-	D4F 712	0,9	LZKAR7A	6799	54	
Thalia 1.4 (LB0/1/2)	LB0, 1, 2	1.4	55	4	08.00-10.05	K7J 700	0,9	BKR5EZ	7642	36	LPG 1
Thalia 1.4 16V (LB0/1/2)	LB0, 1, 2	1.4	72	4	08.00-	K4J 712	0,9	BKR6EZ	4619	38	LPG 1
Thalia 1.6 16V	LU1, 2	1.6	77	4	09.08-	K4M 745	0,9	BKR6EZ	4619	38	LPG 1
Thalia 1.6 16V (LB0/1/2)	LB0, 1, 2	1.6	79	4	04.02-10.05	K4M734, K4M740, K4M745	0,9	BKR6EZ	4619	38	LPG 1

TRAFIC

Trafic T1100 / P1400 / T1400 / V1000		2.0	59	4	09.89-12.97	J5R- 829	0,9	BP6ES	7811	4	LPG 2
--------------------------------------	--	-----	----	---	-------------	----------	-----	-------	------	---	-------





l kW C
Y
I



Stock-N°

VLIVE

LPG/CNG

RENAULT

TRAFIC

Trafic 2.0 16V		2.0	86	4	08.06-	F4R 820	0,9	PFR6G-9	4377		PFR7G
Trafic 2.0		2.0	88	4	03.01-	F4R 720, F4R 722	0,9	PFR6G-9	4377		PFR7G
Trafic T1400		2.2	70	4	05.89-06.94	J7T 600 Cat.	0,8	BP6EFS	3812	5	LPG 5

TRAFIC PHASE II

Trafic II 2.0	EL0L	2.0	86	4	08.06-	F4R820	0,9	PFR6G-9	4377		PFR7G
---------------	------	-----	----	---	--------	--------	-----	---------	------	--	-------

TWINGO

Twingo 0.9 TCe	BCM2	0.9	66	3	09.14-	H4B401	0,7	ILKAR7J7G	91121		
Twingo	C06	1.2	40	4	03.93-06.97	C3G 700	0,9	BP5ESZ	4691		LPG 2
Twingo	C066, C067	1.2	40	4	05.96-03.07	D7F701, D7F706	0,8	BKR5EK	7956	23	LPG 1
Twingo	C066, C068, C06G	1.2	43	4	05.96-06.07	D7F700, D7F702, D7F703	0,8	BKR5EK	7956	23	LPG 1
Twingo	S066, S068, S06G	1.2	43	4	05.96-08.04	D7F704	0,8	BKR5EK	7956	23	LPG 1
Twingo	CN0D, GN0D	1.2	43	4	03.07-09.14	D7F800	0,9	BKR6EZ	4619	38	LPG 1
Twingo	C06	1.2	44	4	04.94-06.97	D7F 730	0,9	BK5ESZ	5675		
Twingo	C06	1.2	44	4	04.00-	D7F GPL	0,8	BKR5EIX	6341		LPG 1
Twingo	CN01, CN04, CN05, CN06, CN0A, CN0B	1.2	55	4	03.07-09.14	D4F772	0,9	LZKAR7B	5942		
Twingo	CN0F	1.2	75	4	02.11-09.14	D4F780	0,7	ILKAR7A7	91432		

TWINGO 2

Twingo 2	CN0	1.2	44	4	08.98-	D7F702, D7F703	0,8	BKR5EK	7956	23	LPG 1
Twingo 2 Euro2000	CN0	1.2	44	4	04.00-	D7F 726	0,9	BKR6EZ	4619	38	LPG 1
Twingo 2	CN0	1.2	44	4	06.07-	D4F 764	0,9	LZKAR7B	5942		
Twingo 2 16V	CN0	1.2	55	4	11.00-	D4F702, D4F703, D4F704, D4F740	0,9	LZKAR7A	6799	54	
Twingo 2	CN0	1.2	55	4	06.07-	D4F722, D4F740	0,9	LZKAR7B	5942		
Twingo 2 Tce 100	CN0	1.2	74	4	06.07-	D4F780, D4F782	0,7	ILKAR7A7	91432		
Twingo 2 1.6 RS	CN0	1.6	98	4	05.08-	K4M 862	0,9	PFR7Z-TG	5768		

TWINGO PHASE I

Twingo 1.2	C066, C068, C06G	1.2	43	4	05.96-06.07	D7F700, D7F701, D7F703, D7F704, D7F708	0,9	BK5ESZ	5675		
Twingo 1.2 LPG	C068, C06G	1.2	43	4	09.00-06.07	D7F704	0,9	BK5ESZ	5675		
Twingo 1.2 LPG	C068, C06G	1.2	43	4	09.00-06.07	D7F704	0,8	BKR5EK	7956	23	LPG 1
Twingo 1.2	C060, C061, C062	1.2	44	4	08.04-06.07	D4F708	0,9	LZKAR7B	5942		

TWINGO PHASE II

Twingo 1.2	CN0D, GN0D	1.2	43	4	03.07-09.14	D7F800	0,8	BKR5EK	7956	23	LPG 1
Twingo 1.2	CN01, CN04, CN05, CN06, CN0A, CN0B, CN0V	1.2	55	4	03.07-09.14	D4F770, D4F772	0,7	ILKAR7A7	91432		
Twingo 1.2	CN01, CN06	1.2	55	4	09.10-09.14	D4F770	0,7	ILKAR7A7	91432		
Twingo 1.2	CN01, CN06	1.2	55	4	09.10-09.14	D4F770	0,9	LZKAR7B	5942		
Twingo 1.2	CN0F	1.2	75	4	02.11-09.14	D4F780	0,7	ILKAR7A7	91432		

VEL SATIS

Vel Satis 16V Turbo	BJ0	2.0	108	4	04.05-08.09	F4R 867	0,9	PFR6G-9	4377		PFR7G
Vel Satis 16V Turbo	BJ0	2.0	120	4	03.02-08.09	F4R 760	0,9	PFR6G-9	4377		PFR7G
Vel Satis	BJ0K, BJ0P	2.0	120	4	06.02-08.09	F4R762, F4R763	0,9	PFR6G-9	4377		PFR7G
Vel Satis	BJ0W	2.0	125	4	04.04-08.09	F4R766, F4R767	0,9	PFR6G-9	4377		PFR7G
Vel Satis	BJ0	2.0	147	4	.06-	F4R 830	0,9	PFR7Z-TG	5768		





kw
C
Y
I



Stock-N°

VLINE

LPG/CNG

RENAULT

VEL SATIS

Vel Satis	BJ0R, BJ0U, BJ0V	3.5	177	6	06.02-08.09	V4Y701	1,1	PLFR5A-11	6240		LPG 7
Vel Satis 2.0	BJ05	2.0	108	4	04.05-08.09	F4R767, F4R867	0,9	PFR7Z-TG	5768		

WIND

Wind	E4MA, E4MF	1.2	74	4	07.10-	D4F782	0,7	ILKAR7A7	91432		
Wind	E4MA	1.2	75	4	02.11-	D4F780	0,7	ILKAR7A7	91432		
Wind	E4MB, E4MC	1.6	98	4	07.10-	K4M854	0,9	PFR7Z-TG	5768		
Wind 1.6	E4MB, E4MC	1.6	98	4	07.10-	K4M854	0,9	PFR6G-9	4377		PFR7G

ROLLS ROYCE

CORNICHE

Corniche 71->02		6.75		8	01.89-06.93		0,9	GR4IX	97382		
Corniche 71->02		6.75		8	09.95-		0,8	BKR5EIX	6341		LPG 1

FLYING SPUR

Flying Spur		6.75		8	08.94-07.95		0,8	BKR5EIX	6341		LPG 1
-------------	--	------	--	---	-------------	--	-----	---------	------	--	-------

PARK WARD

Park Ward		5.4		12	10.00-	V12 BMW	1,5	BKR6EQUIP	3199	30	LPG 1
-----------	--	-----	--	----	--------	---------	-----	-----------	------	----	-------

PHANTOM

Phantom		6.75		8	.68- .91		0,8	BP5ES	6511	8	LPG 2
Phantom		6.8	300	12	01.02-	BMW N73B68	1,5	BKR6EQUIP	3199	30	LPG 1

SILVER DAWN

Silver Dawn		6.75		8	.94- .98		0,8	BKR5EIX	6341		LPG 1
-------------	--	------	--	---	----------	--	-----	---------	------	--	-------

SILVER SERAPH

Silver Seraph		5.4	240	12	.98-07.99	BMW M73B54	0,9	BKR6EK	2288	20	LPG 1
Silver Seraph		5.4	240	12	08.99-	BMW M73B54	1,5	BKR6EQUIP	3199	30	LPG 1

SILVER SPIRIT/ SPUR

Silver Spirit/ Spur		6.75		8	01.89-06.93		0,9	GR4IX	97382		
---------------------	--	------	--	---	-------------	--	-----	-------	-------	--	--

ROVER

111

111		1.1	44	4	.91-	K8 8 VALVE	0,9	BKR6E	6962	28	LPG 1
-----	--	-----	----	---	------	------------	-----	-------	------	----	-------

114

114		1.4	55	4	.91-	K8	0,9	BKR6E	6962	28	LPG 1
114		1.4		4	.91-	K16	0,9	BKR6E	6962	28	LPG 1

211

211		1.1	43	4	01.98-04.99	K Series 8 V	0,8	BKR6ES	3783	28	LPG 1
-----	--	-----	----	---	-------------	--------------	-----	--------	------	----	-------

214

214 Mk.2		1.4		4	10.89-	K SERIES	0,9	BKR6E	6962	28	LPG 1
214 Mk.3		1.4		4	11.95-		0,9	BKR6E	6962	28	LPG 1

216

216 Mk.2		1.6		4	10.89-	SOHC	1,1	BCPR6E-11	3132	11	LPG 3
216 Mk.2		1.6		4	09.90-		1,1	BCPR6E-11	3132	11	LPG 3
216 Mk.3		1.6		4	11.95-		0,9	BKR6E	6962	28	LPG 1

218

218 Mk.3 1.8	RF	1.8	88	4	08.99-03.00	18K4K	1,1	PFR6N-11	3546		LPG 1
218 Mk.3		1.8	107	4	01.96-	K Series with VVC	1,1	PFR6N-11	3546		LPG 1





l kW C
Y
I



Stock-N°

VLINE

LPG/CNG

ROVER

220

220 Mk.2	2.0		4	06.91-	T16 TURBO	0,9	BKR6E	6962	28	LPG 1
----------	-----	--	---	--------	-----------	-----	-------	------	----	-------

25

25 1.1	1.1	44	4	11.99-	K SERIES	1,1	PFR6N-11	3546		LPG 1
25 1.1 16V	1.1	55	4	01.04-	K SERIES	1,1	PFR6N-11	3546		LPG 1
25 1.4 16V	1.4	62	4	11.99-	K SERIES	1,1	PFR6N-11	3546		LPG 1
25 1.6 16V	1.6	80	4	11.99-	K SERIES	1,1	PFR6N-11	3546		LPG 1
25 1.8 16V	1.8	85	4	.99-	K Series with VVC	1,1	PFR6N-11	3546		LPG 1
25 Steptronic	1.8	86	4	05.01-		1,1	PFR6N-11	3546		LPG 1
25 1.8 16V	1.8	107	4	02.00-	K SERIES	1,1	PFR6N-11	3546		LPG 1

414

414 Mk.1	1.4		4	03.90-07.95		0,9	BKR6E	6962	28	LPG 1
414 Mk.2	1.4		4	05.95-		0,9	BKR6E	6962	28	LPG 1

416

Tourer 1.6	1.6	80	4	03.96-04.99	K SERIES	0,8	BKR6ES	3783	28	LPG 1
416 Mk.1	1.6		4	03.90-12.91		1,1	BCPR6E-11	3132	11	LPG 3
416 Mk.1	1.6		4	03.90-	SOHC	1,1	BCPR6E-11	3132	11	LPG 3
416 Mk.2	1.6		4	05.95-	Manual	0,9	BKR6E	6962	28	LPG 1
416 Mk.2	1.6		4	05.95-	Automatik	1,1	BKR6E-11	2756	14	LPG 1

418

418	1.8	105	4	03.96-10.97	K SERIES	1,1	PFR6N-11	3546		LPG 1
-----	-----	-----	---	-------------	----------	-----	----------	------	--	-------

420

420 Mk.1	2.0		4	10.91-11.94		0,9	BKR6E	6962	28	LPG 1
420 Turbo	2.0		4	.92-	T16 TURBO	0,9	BKR6E	6962	28	LPG 1
420 Mk.2	2.0		4	12.95-		0,7	BCP6ES	4930	17	LPG 3

45

45	1.4	76	4	11.99-	K SERIES	1,1	PFR6N-11	3546		LPG 1
45	1.6	80	4	11.99-	K SERIES	1,1	PFR6N-11	3546		LPG 1
45	1.8	86	4	.99-	K SERIES	1,1	PFR6N-11	3546		LPG 1
45	2.0	110	6	.99-	KV6	1,1	PFR6N-11	3546		LPG 1

618

618	1.8		4	02.96-	Honda	1,1	ZFR6F-11	4291		LPG 6
-----	-----	--	---	--------	-------	-----	----------	------	--	-------

620

620	2.0	85	4	04.93-	Honda	1,1	ZFR6F-11	4291		LPG 6
620 Turbo	2.0		4	.94-	T Series	0,9	BKR6E	6962	28	LPG 1

623

623	2.3	116	4	04.94-	Honda	1,1	ZFR6F-11	4291		LPG 6
-----	-----	-----	---	--------	-------	-----	----------	------	--	-------

75

75	1.8	87	4	02.99-	K SERIES	1,1	PFR6N-11	3546		LPG 1
75 1.8	RJ	1.8	110	4	11.02-04.05	18K4FT	1,1	PFR6N-11	3546	LPG 1
75 Tourer 1.8	RJ	1.8	110	4	11.02-04.05	18K4FT	1,1	PFR6N-11	3546	LPG 1
75 Turbo		1.8		4	07.02-	K SERIES	1,1	PFR6N-11	3546	LPG 1
75		2.0	109	6	02.99-	K V6	1,1	PFR6N-11	3546	LPG 1
75		2.5	128	6	02.99-	K V6	1,1	PFR6N-11	3546	LPG 1

820

820 Turbo	2.0	132	4	10.92-	20T4 TURBO MPI	0,9	BKR6E	6962	28	LPG 1
-----------	-----	-----	---	--------	----------------	-----	-------	------	----	-------





l kW C
Y
I



Stock-N°

VLINE

LPG/CNG

ROVER

820

820	2.0		4	07.86-10.91	M16 Inj.	0,9	BKR6E	6962	28	LPG 1
820	2.0		4	03.91-10.91	M16 Turbo Inj.	0,9	BKR6E	6962	28	LPG 1
820	2.0		4	11.91-	T16, Turbo, Inj.	0,9	BKR6E	6962	28	LPG 1
820 i	2.0		4	.91-	20T4 MPI	0,9	BKR6E	6962	28	LPG 1

825

825 i	2.5		6	01.96-	KV6	0,9	BKR6E	6962	28	LPG 1
-------	-----	--	---	--------	-----	-----	-------	------	----	-------

827

827	2.7		6	02.88-01.96	C27A V6	1,1	BCPR6E-11	3132	11	LPG 3
-----	-----	--	---	-------------	---------	-----	-----------	------	----	-------

CITY ROVER

City Rover 1.4	1.4		4	10.03-	K SERIES	0,8	BK6E	3536		LPG 1
----------------	-----	--	---	--------	----------	-----	------	------	--	-------

MAESTRO

Maestro	1.3	51	4	03.89-12.94		0,8	BPR6ES	7822	2	LPG 2
Maestro	1.6	63	4	07.89-04.92	S Series	0,8	BCPR6ES	2330	12	LPG 3

METRO

Metro	1.1		4	05.90-12.94	K8	0,9	BKR6E	6962	28	LPG 1
Metro /16V/16V GTI	1.4		4	05.90-01.95	K8, K16, K16	0,9	BKR6E	6962	28	LPG 1

MG RV8

MG RV8	3.9	140	8	.94-	V8i	0,8	BPR6ES	7822	2	LPG 2
--------	-----	-----	---	------	-----	-----	--------	------	---	-------

MINI

Mini	1.0		4	10.89-04.92		0,8	BPR6ES	7822	2	LPG 2
Mini Cooper i	1.3	46	4	.91-	12A2EF77 / SPI	0,8	BPR6ES	7822	2	LPG 2
Mini	1.3		4	10.89-	not Turbo	0,8	BPR6ES	7822	2	LPG 2

MONTEGO

Montego	1.4		4	12.94-		0,7	BCP6ES	4930	17	LPG 3
Montego	1.6		4	04.89-01.93		0,8	BCPR6ES	2330	12	LPG 3
Montego	2.0		4	04.89-12.94		0,8	BPR6ES	7822	2	LPG 2

STERLING

Sterling	2.5		6	10.87-	C25A V6	0,8	BCPR6ES	2330	12	LPG 3
Sterling	2.7		6	02.88-	C27A V6	1,1	BCPR6E-11	3132	11	LPG 3

STREETWISE

Streetwise 1.4	1.4		4	07.03-	K SERIES	1,1	PFR6N-11	3546		LPG 1
Streetwise 1.6	1.6		4	07.03-	K SERIES	1,1	PFR6N-11	3546		LPG 1
Streetwise 1.8	RF 1.8	86	4	08.03-12.05	18K4F	1,1	PFR6N-11	3546		LPG 1
Streetwise 1.8	1.8		4	07.03-	K SERIES	1,1	PFR6N-11	3546		LPG 1

SAAB

900

900	2.0	74	4	- .93	B201C	0,7	BP6ES	7811	4	LPG 2
900	2.0	96	4	08.94-02.98	B204i	0,7	PFR5A-11	4588		
900	2.0	136	4	10.93-	B204L	1,1	BCPR7ES-11	1095		
900 Turbo	2.0		4	.83- .93	B201 with APC	0,8	BPR7EIX	4055		BPR8EIX
900	2.0		4	- .93	B202	0,7	BCPR5EIX	5688		
900 S/Cabrio.	2.0		4	- .93	B202S	0,6	BCPR7EIX	5690		BCPR7EIX
900 Turbo 16V	2.0		4	- .93	B202	0,8	BCPR7EIX	5690		BCPR7EIX
900	2.0		4	- .93	B212	0,7	PFR5A-11	4588		
900	2.3	110	4	10.93-	B234i	0,7	BCPR6EIX	5689		LPG 3





e kW C
Y
I



Stock-N°

VLINE

LPG/CNG

SAAB

900

900	2.5	125	6	.94-	B258 Motronic	0,8	BKR5EK	7956	23	LPG 1
900	2.5		6	10.93-	B258i, B308i	0,9	BKR6EK	2288	20	LPG 1

9000

9000	2.0	87	4	09.84-12.98	B202L	1,1	BCPR7ES-11	1095		
9000	2.0	96	4	.94- .98	B204i	1,1	BCPR6ES-11	7121	11	LPG 3
9000	2.0	110	4	.94- .98	B204 E	1,1	BCPR7ES-11	1095		
9000	2.0		4	.94- .96	B202 mit Di	0,8	BCPR7ES	3330		BCPR7EIX
9000	2.0		4	- .93	B202i ohne Di	0,7	BCPR5EIX	5688		
9000	2.3	96	4	.94- .96	B234i	0,7	BCPR6EIX	5689		LPG 3
9000 CS 2.3-16	2.3	107	4	09.91-12.98	B234i Cat.	1,1	BCPR6ES-11	7121	11	LPG 3
9000	2.3	125	4	.94- .98	B234 E	1,1	BCPR7ES-11	1095		
9000	2.3	147	4	.92- .98	B234L	1,1	BCPR7ES-11	1095		
9000 Aero	2.3	165	4	.93- .98	B234R	1,1	BCPR7ES-11	1095		
9000 V6	3.0	155	6	11.94-12.98	B308 V6	0,8	BKR5EK	7956	23	LPG 1

9-3

9-3 1.8	C75, D75, E75	1.8	90	4	07.05-02.15	Z18XE	0,8	ZFR5F	5165	53	LPG 6
9-3 2.0	D3D, D5D, D7D	2.0	96	4	03.98-10.00	B204i	0,7	BCPR5EIX	5688		
9-3 2.0 T BioPower	D45	2.0	120	4	01.07-12.07	B207H	1,1	BKR7ESC-11	6313		
9-3 2.0 T16	C75, D75, E75	2.0	143	4	04.06-02.15	B207L	1,0	PFR6T-10G	5542		
9-3 2.0 T BioPower (Engine-No. →11765305)	C75	2.0	145	4	06.07-12.09	B207R	1,1	BKR7ESC-11	6313		
9-3 2.0 T BioPower (Engine No. 11765306→)	C75	2.0	145	4	01.10-02.15	B207R	1,0	PFR6D10G	1632		
9-3 2.0 T16	D3D, D5D	2.0	147	4	02.98-09.02	B204R	1,0	PFR7H-10	3978		
9-3 2.0 T16	E45, E49	2.0	147	4	09.07-12.07	B207M	1,0	PFR6T-10G	5542		
9-3 2.0 T BioPower	C75, D45, E50	2.0	162	4	01.11-02.15	A20NFT	0,9	ILTR5D	5476		
9-3 2.0 T16	C75, D45, E50	2.0	162	4	01.11-02.15	A20NFT	0,9	ILTR5D	5476		
9-3 X 2.0 T BioPower	YS3	2.0	162	4	01.11-02.15	A20NFT	0,9	ILTR5D	5476		
9-3 X 2.0 T16	YS3	2.0	162	4	01.11-02.15	A20NFT	0,9	ILTR5D	5476		
9-3 2.0 T16	D45, E50	2.0	177	4	05.09-02.15	B207R	1,0	PFR6D10G	1632		
9-3 2.0 T16	C75, D46	2.0	185	4	04.04-02.15	B207R	1,0	PFR6T-10G	5542		
9-3 2.3	D3D, D5D, D7D	2.3	110	4	03.98-02.99	B234i	0,7	BCPR6EIX	5689		LPG 3
9-3 2.8 V6 T	D45, E75	2.8	169	6	03.05-12.07	B284L	1,0	PLFR6C-10G	1959		
9-3 2.8 V6 T	C75	2.8	169	6	02.06-12.07	B284L	1,0	PLFR6C-10G	1959		
9-3 2.8 V6 T	D45, C75, E75	2.8	169	6	01.08-02.15	B284L	1,0	DILFR7B10G	97218		
9-3 2.8 V6 T	D75, D79	2.8	203	6	04.08-02.15	B284R	1,0	DILFR7B10G	97218		
9-3 2.8 V6 T	E75, E79	2.8	203	6	05.08-02.15	B284R	1,0	DILFR7B10G	97218		
9-3 2.8 V6 T	C75, C79	2.8	206	6	09.07-12.07	B284R	1,0	PLFR6C-10G	1959		

9-3 1

9-3 2.0i	YS3D	2.0	96	4	02.98-08.03	B204i	0,7	PFR5A-11	4588		
9-3 16V Pack	YS3D	2.0	96	4	04.98-	B204i	0,7	PFR5A-11	4588		
9-3 2.0 Turbo	YS3D	2.0	110	4	03.99-08.03	B205E	0,7	PFR5A-11	4588		
9-3 2.0 Turbo	YS3D	2.0	113	4	10.98-08.03	B204E	1,1	BCPR7ES-11	1095		
9-3 2.0 Turbo	YS3D	2.0	136	4	02.98-07.03	B204L	1,1	BCPR7ES-11	1095		





l kW C
Y
I



Stock-Nº

VLINE

LPG/CNG

SAAB

9-3 1

9-3 2.0 Turbo	YS3D	2.0	136	4	02.98-07.03	B205L	1,0	PFR6H-10	6290		PFR7H-10
9-3 2.0 SE Turbo	YS3D	2.0	147	4	02.98-08.03	B204R	1,1	BCPR7ES-11	1095		
9-3 2.0 Turbo	YS3D	2.0	151	4	09.99-08.03	B205R	1,0	PFR6H-10	6290		PFR7H-10
9-3 2.3i	YS3D	2.3	110	4	02.98-08.03	B234I	1,0	PFR6H-10	6290		PFR7H-10
9-3 2.3 Turbo	YS3D	2.3	165	4	10.98-03.03	B235R	1,0	PFR6H-10	6290		PFR7H-10
9-3 2.3	YS3D	2.3	169	4	09.99-12.02	B235R	1,0	PFR6H-10	6290		PFR7H-10

9-3 2

9-3 1.8i	YS3F	1.8	90	4	11.03-03.09	Z18XE	0,6	BKR5EQUPA	3566		
9-3 1.8t	YS3F	2.0	110	4	09.02-12.07	B207E	1,0	PFR6T-10G	5542		
9-3 2.0t	YS3F	2.0	110	4	03.05-12.07	B207E	1,0	PFR6T-10G	5542		
9-3 1.8t BioPower	YS3F	2.0	110	4	01.07-12.07	B207E	1,1	BKR7ESC-11	6313		
9-3 1.8t	YS3F	2.0	110	4	01.08-07.12	B207E	1,0	PFR6D10G	1632		
9-3 1.8t BioPower	YS3F	2.0	110	4	01.08-07.12	B207E	1,0	PFR6D10G	1632		
9-3 2.0t	YS3F	2.0	110	4	01.08-07.12	B207E	1,0	PFR6D10G	1632		
9-3 2.0t	YS3F	2.0	120	4	01.07-12.07	B207R	1,0	PFR6T-10G	5542		
9-3 2.0t	YS3F	2.0	120	4	01.08-07.12	B207R	1,0	PFR6D10G	1632		
9-3 2.0t	YS3F	2.0	129	4	09.02-12.07	B207L	1,0	PFR6T-10G	5542		
9-3 1.8t BioPower (Engine No->11765305)	YS3F	2.0	129	4	01.07-12.09	B207L	1,1	BKR7ESC-11	6313		
9-3 2.0t	YS3F	2.0	129	4	01.08-07.12	B207L	1,0	PFR6D10G	1632		
9-3 1.8t BioPower (Engine No 11765306->)	YS3F	2.0	129	4	01.10-07.12	B207L	1,0	PFR6D10G	1632		
9-3 2.0t	YS3F	2.0	147	4	06.07-12.07	B207R	1,0	PFR6T-10G	5542		
9-3 Turbo Bio Power	YS3F	2.0	147	4	07.07-07.12	B207, Z20NFL	1,1	BKR7ESC-11	6313		
9-3 2.0t	YS3F	2.0	147	4	01.08-07.12	B207R	1,0	PFR6D10G	1632		
9-3 2.0 T	YS3F	2.0	154	4	09.02-12.07	B207R	1,0	PFR6T-10G	5542		
9-3 2.0 T	YS3F	2.0	154	4	01.08-07.12	B207R	1,0	PFR6D10G	1632		
9-3 2.0 T	YS3F	2.0	162	4	01.11-07.12	B207R, A20NFT	1,0	PFR6D10G	1632		
9-3 2.0 T Aero	YS3F	2.0	177	4	05.09-07.12	B207R	1,0	PFR6D10G	1632		
9-3 2.5 V6	YS3F	2.5	125	6	.98-07.12	B258 Motronic	0,8	BKR5EK	7956	23	LPG 1
9-3 2.8 Turbo Aero	YS3F	2.8	169	6	04.05-07.12	B284E HFV6	1,0	PLFR6C-10G	1959		
9-3 2.8 Turbo V6	YS3F	2.8	184	6	03.05-12.07	B284E, B284L	1,0	PLFR6C-10G	1959		
9-3 2.8 Turbo V6	YS3F	2.8	184	6	01.08-07.12	B284E, B284L	1,0	DILFR7B10G	97218		
9-3 2.8 Turbo V6	YS3F	2.8	188	6	09.07-12.07	B284L	1,0	PLFR6C-10G	1959		
9-3 2.8 Turbo V6	YS3F	2.8	188	6	01.08-07.12	B284L	1,0	DILFR7B10G	97218		
9-3 2.8 Turbo V6	YS3F	2.8	203	6	02.09-07.12	B284R	1,0	DILFR7B10G	97218		
9-3 2.8 Turbo V6	YS3F	2.8	206	6	09.07-12.07	B284R	1,0	PLFR6C-10G	1959		
9-3 2.8 Turbo V6	YS3F	2.8	206	6	01.08-07.12	B284R	1,0	DILFR7B10G	97218		

9-3X

9-3X 2.0 T BioPower XWD	YS3F	2.0	154	4	02.09-07.12	B207R	1,1	BKR7ESC-11	6313		
9-3X 2.0 T XWD	YS3F	2.0	154	4	02.09-07.12	B207R	1,0	PFR6T-10G	5542		
9-3X 2.0 T BioPower XWD	YS3F	2.0	162	4	01.11-07.12	B207R	1,0	PFR6D10G	1632		

9-5

9-5 2.0 T16	D4S	2.0	110	4	09.97-05.10	B205E	1,1	BCPR6ES-11	7121		LPG 3
9-5 2.0 T16	D4S	2.0	110	4	09.97-05.10	B205E	1,0	PFR7H-10	3978		
9-5 2.0 T16	D5S	2.0	110	4	10.98-05.10	B205E	1,0	PFR7H-10	3978		





l kW C
Y
I



Stock-N°

VLINE

LPG/CNG

SAAB

9-5

9-5 2.0 T BioPower	EB4, EB5	2.0	132	4	09.05-05.10	B205E	1,1	BCPR7ES-11	1095		
9-5 2.0 T16	D4S, D5S	2.0	136	4	07.00-07.01	B205L	1,1	BCPR6ES-11	7121		LPG 3
9-5 2.0 T16	D4S, D5S	2.0	136	4	07.00-07.01	B205L	1,0	PFR7H-10	3978		
9-5 2.0 T16	D4S, D5S	2.0	141	4	10.98-07.00	B205E	1,1	BCPR6ES-11	7121		LPG 3
9-5 2.0 T16	D4S	2.0	141	4	10.98-07.00	B205E	1,0	PFR7H-10	3978		
9-5 2.3 T16	EB4	2.3	134	4	04.08-05.10	B235E	1,1	BCPR6ES-11	7121		LPG 3
9-5 2.3 T16	D4S, D5S	2.3	162	4	06.03-05.10	B235L, B235R	1,1	BCPR6ES-11	7121		LPG 3
9-5 2.3 T16	EB4	2.3	188	4	04.08-05.10	B235R	1,0	PFR6H-10	6290		PFR7H-10
9-5 2.3 T16	EB4	2.3	188	4	04.08-05.10	B235R	1,0	PFR7H-10	3978		

9-5 1

9-5 2.0t	YS3E	2.0	110	4	09.97-05.10	B205E	1,1	BCPR7ES-11	1095		
9-5 2.0t Bio Power	YS3E	2.0	132	4	07.07-05.10	A20NHL	1,1	BKR7ESC-11	6313		
9-5 2.0t SE	YS3E	2.0	136	4	07.00-07.01	B205L	1,0	PFR6H-10	6290		PFR7H-10
9-5 2.0t	YS3E	2.0	140	4	09.97-07.00	B205E Trim Kit	1,0	PFR6H-10	6290		PFR7H-10
9-5 2.3t	YS3E	2.3	125	4	09.97-07.01	B235E	1,1	BCPR6ES-11	7121	11	LPG 3
9-5 2.3t	YS3E	2.3	136	4	09.99-05.10	B235E	1,1	BCPR6ES-11	7121	11	LPG 3
9-5 2.3 Turbo	YS3E	2.3	162	4	07.03-05.10	B235L	1,0	PFR6H-10	6290		PFR7H-10
9-5 2.3 Turbo	YS3E	2.3	165	4	07.98-05.10	B235R	1,0	PFR6H-10	6290		PFR7H-10
9-5 2.3 Turbo	YS3E	2.3	169	4	10.99-09.01	B235R	1,0	PFR6H-10	6290		PFR7H-10
9-5 2.3 Turbo	YS3E	2.3	184	4	10.99-05.10	B235R	1,0	PFR6H-10	6290		PFR7H-10
9-5 2.3 Turbo	YS3E	2.3	191	4	11.05-05.10	B235R	1,0	PFR6H-10	6290		PFR7H-10
9-5 3.0 V6	YS3E	3.0	147	6	09.97-08.05	B308E	1,1	BKR7ES-11	2387		BKR8EIX

9-5 2

9-5 1.6T	YS3G	1.6	132	4	05.10-07.12	A16LET	0,9	ZFR6BP-G	1748		LPG6
9-5 2.0T	YS3G	2.0	162	4	05.10-07.12	A20NHT	0,9	ILTR5D	5476		
9-5 2.0T Bio Power	YS3G	2.0	162	4	05.10-07.12	A20NFT	0,9	ILTR5D	5476		
9-5 2.8 T V6 XWD	YS3G	2.8	221	6	05.10-07.12	A28NER	1,0	DILFR7B10G	97218		

SEAT

ALHAMBRA 1995

Alhambra 1.8 T	7V8, 7V9	1.8	110	4	05.98-02.00	AJH	1,0	BKR6ETA-10	7998		
Alhambra 2.0	7V8, 7V9	2.0	85	4	03.96-02.00	ADY	0,8	BKUR6ET	6437	27	LPG 1
Alhambra 2.8 V6	7V8, 7V9	2.8	128	6	06.96-	AAA	0,6	BKR5EKUP	2890		

ALHAMBRA 2000

Alhambra 1.8 T	7V8, 7V9	1.8	110	4	06.00-03.10	AWC	0,8	PFR6Q	6458	37	LPG 1
Alhambra 2.0	7V8, 7V9	2.0	85	4	06.00-03.10	ATM	1,0	BKUR6ET-10	2397	24	LPG 1
Alhambra 2.8 V6	7V8, 7V9	2.8	150	6	06.00-04.02	AUE	1,1	PZFR5D-11	7968	34	LPG 6
Alhambra 2.8 V6	7V8, 7V9	2.8	150	6	06.00-03.10	AYL	1,1	PZFR5D-11	7968	34	LPG 6

ALHAMBRA 2010

Alhambra 2 1.4 TSI	710	1.4	110	4	06.10-	CAVA, CNWB, CTHA	0,8	SIZFR6B8EG	96209		
Alhambra 2 2.0 TSI	710	2.0	147	4	11.10-	CCZA	0,8	PFR7S8EG	1675	50	PFR8S8EG

ALTEA

Altea 1.2 TSI	5P1	1.2	77	4	04.10-	CBZB	0,7	IZFR6P7	97153		
Altea 1.4	5P1	1.4	63	4	05.06-	BXW	1,1	ZFR6T-11G	5960	44	
Altea 1.4	5P1	1.4	63	4	05.10-	CGGB	1,1	ZFR6T-11G	5960	44	
Altea 1.4 TSI	5P1	1.4	92	4	11.07-	CAXC	0,9	PZFR6R	5758	52	





l kW C
Y
I



Stock-Nº

VLINE

LPG/CNG

SEAT

ALTEA

Altea 1.6	5P1	1.6	75	4	03.04-05.05	BGU	1,0	BKUR6ET-10	2397	24	LPG 1
Altea 1.6	5P1	1.6	75	4	05.05-	BSE	1,0	BKUR6ET-10	2397	24	LPG 1
Altea 1.6	5P1	1.6	75	4	05.05- .09	BSF	1,0	BKUR6ET-10	2397	24	LPG 1
Altea XL 1.6 Multifuel	5P5	1.6	75	4	10.06-	BSE, BSF, CCSA, CMXA	1,0	BKUR6ET-10	2397	24	LPG 1
Altea 1.6	5P1	1.6	75	4	12.07-	CCSA	1,0	BKUR6ET-10	2397	24	LPG 1
Altea 1.6 LPG	5P1	1.6	75	4	09.09-	CHGA	1,0	BKUR6ET-10	2397	24	LPG 1
Altea 1.6 Multifuel	5P1	1.6	75	4	11.10-05.11	CMXA	1,0	BKUR6ET-10	2397	24	LPG 1
Altea 1.8 TFSI	5P1	1.8	118	4	01.07-06.07	BYT	0,8	PFR7S8EG	1675	50	PFR8S8EG
Altea 1.8 TFSI	5P1	1.8	118	4	06.07-03.09	BZB	0,8	PFR7S8EG	1675	50	PFR8S8EG
Altea 1.8 TFSI	5P1	1.8	118	4	03.09-	CDA	0,8	PFR7S8EG	1675	50	PFR8S8EG
Altea 2.0 FSI	5P1	2.0	110	4	05.04-11.05	BLR	1,1	PZFR5N-11T	7742		
Altea 2.0 FSI	5P1	2.0	110	4	11.04-11.05	BLY	0,9	BKR6E	6962	28	LPG 1
Altea 2.0 FSI	5P1	2.0	110	4	11.05-	BVZ	0,9	BKR6E	6962	28	LPG 1
Altea 2.0 FSI	5P1	2.0	110	4	11.05-	BVY	1,1	PZFR5N-11T	7742		
Altea 2.0 TFSI	5P1	2.0	147	4	02.06-05.09	BWA	0,8	PFR7S8EG	1675	50	PFR8S8EG

ALTEA XL

Altea XL 1.6	5P5	1.6	75	4	10.06-06.13	CMXA	1,0	BKUR6ET-10	2397	24	LPG 1
Altea XL 1.6 Multifuel	5P5	1.6	75	4	10.06-	CMXA	1,0	BKUR6ET-10	2397	24	LPG 1
Altea XL 1.6 LPG	5P5	1.6	75	4	09.09-	CHGA	1,0	BKUR6ET-10	2397	24	LPG 1
Altea XL 2.0 TFSI 4x4	5P5	2.0	155	4	05.09-	CCZB	0,8	PFR7S8EG	1675	50	PFR8S8EG

ARONA

Arona 1.0 TGi	KJ7	1.0	66	3	11.18-	DBYA	0,8	PKER7A8DES	97861		
Arona 1.0 TSi	KJ7	1.0	70	3	07.17-	CHZL, DKLA	0,8	PKER7A8EGS	95463		
Arona 1.0 TSi	KJ7	1.0	81	3	06.20-	DLAA	0,8	ILKER7A8EGS	95929		
Arona 1.0 TSi	KJ7	1.0	85	3	07.17-	CHZJ, DKJA, DKRF	0,8	IKER7A8EGS	94224		
Arona 1.5 TSi	KJ7	1.5	110	4	07.17-	DADA, DPCA	0,8	ILKER7A8EGS	95929		

AROSA

Arosa 1.0	6H	1.0	37	4	02.97-09.99	AER	0,8	BUR6ET	3172	1	LPG 2
Arosa 1.0	6H	1.0	37	4	08.97-06.99	ALL	0,8	BUR6ET	3172	1	LPG 2
Arosa 1.0	6H	1.0	37	4	11.98-02.00	AHT	1,0	BKR6ETA-10	7998		
Arosa 1.0	6H	1.0	37	4	07.99-07.00	ALD, ANV	1,1	PZFR5D-11	7968	34	LPG 6
Arosa 1.0	6H	1.0	37	4	07.00-06.04	AUC	1,1	PZFR5D-11	7968	34	LPG 6
Arosa 1.4	6H	1.4	44	4	02.97-11.97	AEX	0,8	BUR6ET	3172	1	LPG 2
Arosa 1.4	6H	1.4	44	4	05.97-09.99	AKV	0,8	BUR6ET	3172	1	LPG 2
Arosa 1.4	6H	1.4	44	4	12.97-08.99	APQ	0,8	BUR6ET	3172	1	LPG 2
Arosa 1.4	6H	1.4	44	4	07.99-10.00	AKK, ANW	1,1	PZFR5D-11	7968	34	LPG 6
Arosa 1.4	6H	1.4	44	4	09.00-06.04	AUD	1,1	PZFR5D-11	7968	34	LPG 6
Arosa 16V	6H	1.4	55	4	01.98-	AHW	1,0	BKUR6ET-10	2397	24	LPG 1
Arosa 1.4 16V	6H	1.4	74	4	01.99-09.00	AFK	1,0	BKUR6ET-10	2397	24	LPG 1
Arosa 1.4 16V	6H	1.4	74	4	01.99-	ANM	1,0	BKUR6ET-10	2397	24	LPG 1
Arosa 1.4 16V	6H	1.4	74	4	10.99-09.00	AQQ	1,0	BKUR6ET-10	2397	24	LPG 1
Arosa 1.4 16V	6H	1.4	74	4	09.00-06.04	AUB	1,0	BKUR6ET-10	2397	24	LPG 1

ATECA

Ateca 1.0 TSi	KH7	1.0	85	3	04.16-	CHZJ, DKRF	0,8	IKER7A8EGS	94224		
Ateca 1.4 Tsi ACT	KH7	1.4	110	4	06.16-	CZEA	0,8	PZKER7B8EGS	93231	55	





e kW C
Y
I



Stock-N°

VLINE

LPG/CNG

SEAT

ATECA

Ateca 1.5 TSi	KH7	1,5	110	4	07.18-	DADA	0,8	ILKER7A8EGS	95929		
---------------	-----	-----	-----	---	--------	------	-----	-------------	-------	--	--

CORDOBA

Cordoba / Vario		1,0	37	4	09.96-	AER	0,8	BUR6ET	3172	1	LPG 2
Cordoba 1.0	6K2	1,0	37	4	09.96-09.02	AER, ALD, ANV, AUC	1,1	PZFR5D-11	7968	34	LPG 6
Cordoba / Vario		1,0	37	4	08.99-08.02	ALD	1,1	PZFR5D-11	7968	34	LPG 6
Cordoba / Vario		1,0	37	4	08.99-07.00	ANV	1,1	PZFR5D-11	7968	34	LPG 6
Cordoba		1,0	37	4	07.00-	AUC	1,1	PZFR5D-11	7968	34	LPG 6
Cordoba		1,0	51	4	05.00-	AVZ	1,0	BKUR6ETB-10	5742		
Cordoba 12V		1,2	47	3	05.05-06.06	BME	0,9	ZFR5P-G	6893	41	LPG 6
Cordoba		1,3	40	4	02.93-08.94	AAV	0,8	BP5ET	2287		LPG 2
Cordoba		1,3	40	4	02.93-08.94	2G	0,8	BUR6ET	3172	1	LPG 2
Cordoba		1,4	40	4	01.98-	ANX	0,8	BUR6ET	3172	1	LPG 2
Cordoba		1,4	44	4	09.93-12.95	ABD	0,8	BP5ET	2287		LPG 2
Cordoba 1.4	6K2	1,4	44	4	06.94-10.02	ABD, AEX, AKK, AKV, ANW, APQ, AUD	1,1	PZFR5D-11	7968	34	LPG 6
Cordoba / Vario		1,4	44	4	09.95-12.97	AEX	0,8	BUR6ET	3172	1	LPG 2
Cordoba Vario 1.4	6K5	1,4	44	4	09.96-08.02	AEX, AKK, AKV, ANW, APQ, AUD	1,1	PZFR5D-11	7968	34	LPG 6
Cordoba / Vario		1,4	44	4	09.97-	AKV	0,8	BUR6ET	3172	1	LPG 2
Cordoba / Vario		1,4	44	4	12.97-05.98	APQ	0,8	BUR6ET	3172	1	LPG 2
Cordoba / Vario		1,4	44	4	05.99-08.00	ANW	1,1	PZFR5D-11	7968	34	LPG 6
Cordoba / Vario		1,4	44	4	08.99-08.02	AKK	1,1	PZFR5D-11	7968	34	LPG 6
Cordoba / Vario		1,4	44	4	06.00-	AUD	1,1	PZFR5D-11	7968	34	LPG 6
Cordoba 16V		1,4	55	4	05.99-06.00	APE	1,0	BKUR6ET-10	2397	24	LPG 1
Cordoba 16V		1,4	55	4	06.00-	AUA	1,0	BKUR6ET-10	2397	24	LPG 1
Cordoba 16 V Automatic		1,4	55	4	09.02-04.04	BBY	1,1	PZFR5D-11	7968	34	LPG 6
Cordoba 16 V		1,4	55	4	05.04-	BKY	1,0	BKUR6ET-10	2397	24	LPG 1
Cordoba 16 V Automatic		1,4	55	4	05.04-	BKY	1,1	PZFR5D-11	7968	34	LPG 6
Cordoba		1,4	63	4	05.06-	BXW	1,1	ZFR6T-11G	5960	44	
Cordoba 1.4	6K2	1,4	74	4	09.96-09.02	AFH, AQQ, AUB	1,0	BKUR6ET-10	2397	24	LPG 1
Cordoba / Vario 16V		1,4	74	4	06.97-	AFH	0,8	BKUR6ET	6437	27	LPG 1
Cordoba / Vario 16V		1,4	74	4	09.99-07.00	AQQ	1,0	BKUR6ET-10	2397	24	LPG 1
Cordoba Vario 1.4	6K5	1,4	74	4	02.00-07.00	AQQ	1,0	BKUR6ET-10	2397	24	LPG 1
Cordoba / Vario 16V		1,4	74	4	07.00-	AUB	1,0	BKUR6ET-10	2397	24	LPG 1
Cordoba 16 V		1,4	74	4	05.05-	BBZ	1,0	BKUR6ET-10	2397	24	LPG 1
Cordoba		1,6	52	4	11.93-	ABM	0,8	BUR5ET	3377	22	LPG 2
Cordoba		1,6	55	4	02.93-07.94	ABU	0,8	BUR6ET	3172	1	LPG 2
Cordoba / Vario		1,6	55	4	09.94-09.97	1F	0,8	BUR5ET	3377	22	LPG 2
Cordoba / Vario		1,6	55	4	05.97-12.98	AEE	0,8	BUR6ET	3172	1	LPG 2
Cordoba / Vario		1,6	55	4	09.97-08.02	ALM	0,8	BUR6ET	3172	1	LPG 2
Cordoba / Vario		1,6	74	4	09.95-05.98	AFT	1,0	BKUR6ET-10	2397	24	LPG 1
Cordoba		1,6	74	4	01.96-	AEK	0,8	BKUR5ET	2789	29	LPG 1
Cordoba		1,6	74	4	05.99-08.02	AKL	1,0	BKUR6ET-10	2397	24	LPG 1
Cordoba / Vario		1,6	74	4	05.99-08.02	AEH	1,0	BKUR6ET-10	2397	24	LPG 1
Cordoba / Vario		1,6	74	4	03.00-10.00	APF	1,0	BKUR6ET-10	2397	24	LPG 1
Cordoba / Vario		1,6	74	4	05.00-	AUR	1,0	BKUR6ET-10	2397	24	LPG 1





l kW C
Y
I



Stock-N°

VLINE

LPG/CNG

SEAT

CORDOBA

Cordoba		1.6	77	4	11.06-	BTS	1,1	ZFR6T-11G	5960	44	
Cordoba		1.8	55	4	08.91-	AAM	0,8	BUR5ET	3377	22	LPG 2
Cordoba		1.8	66	4	02.93-08.94	ABS	0,8	BUR6ET	3172	1	LPG 2
Cordoba / Vario		1.8	66	4	07.94-	ADZ	0,8	BUR6ET	3172	1	LPG 2
Cordoba		1.8	66	4	07.96-	ACC	0,8	BUR6ET	3172	1	LPG 2
Cordoba		1.8	95	4	02.94-06.96	ADL	0,8	BKUR7ET	7873		
Cordoba 20V		1.8	115	4	12.99-	AQX	1,0	BKUR6ET-10	2397	24	LPG 1
Cordoba		1.8	115	4	09.00-	AYP	1,0	BKUR6ET-10	2397	24	LPG 1
Cordoba		2.0	85	4	02.93-06.96	2E	0,8	BUR6ET	3172	1	LPG 2
Cordoba / Vario		2.0	85	4	04.96-	AGG	0,8	BUR6ET	3172	1	LPG 2
Cordoba		2.0	85	4	09.02-	AZL	1,0	BKUR6ET-10	2397	24	LPG 1
Cordoba 2.0	6L2	2.0	85	4	09.02-11.09	AZL, BBX	1,0	BKUR6ET-10	2397	24	LPG 1
Cordoba		2.0	85	4	04.03-	BBX	1,0	BKUR6ET-10	2397	24	LPG 1
Cordoba 16V		2.0	110	4	07.96-	ABF	1,0	BKUR6ET-10	2397	24	LPG 1

EXEO

Exeo 1.6	3R2, 3R5	1.6	75	4	03.09-09.10	ALZ	1,0	BKUR6ET-10	2397	24	LPG 1
Exeo 1.8 TSi	3R2, 3R5	1.8	88	4	09.10-05.13	CDHA	0,8	PFR7S8EG	1675	50	PFR8S8EG
Exeo 1.8 T	3R2, 3R5	1.8	110	4	12.08-05.10	CFMA	0,8	PFR6Q	6458	37	LPG 1
Exeo 1.8 TSi	3R2, 3R5	1.8	118	4	05.10-05.13	CDHB	0,8	PFR7S8EG	1675	50	PFR8S8EG
Exeo 2.0 TFSI	3R2, 3R5	2.0	147	4	03.09-05.13	BWE	0,8	PFR7S8EG	1675	50	PFR8S8EG
Exeo 2.0 TFSI	3R2, 3R5	2.0	155	4	05.10-05.13	CDND	0,8	PFR7S8EG	1675	50	PFR8S8EG

IBIZA

Ibiza 1.0	6K1	1.0	37	4	09.96-05.02	AER, ALD, ANV, AUC	1,1	PZFR5D-11	7968	34	LPG 6
Ibiza 1.0 MPi	KJ1	1.0	48	3	07.17-	CHYC, DFNB	1,0	ZKER6A-10EG	96596		
Ibiza 1.0 MPi	KJ1	1.0	55	3	01.17-	CHYB	1,0	ZKER6A-10EG	96596		
Ibiza 1.2	6J5	1.2	44	3	07.09-05.11	CGPB	1,1	ZFR6T-11G	5960	44	
Ibiza SC 1.2	6J1	1.2	44	3	07.09-05.15	CGPB	1,1	ZFR6T-11G	5960	44	
Ibiza ST 1.2	6J8	1.2	44	3	05.10-05.15	CGPB	1,1	ZFR6T-11G	5960	44	
Ibiza 1.2 LPG	6J5	1.2	51	3	03.08-05.11	BZG	1,1	ZFR6T-11G	5960	44	
Ibiza SC 1.2	6J1	1.2	51	3	04.08-05.15	CGPA	1,1	ZFR6T-11G	5960	44	
Ibiza 1.4 LPG	6J5	1.4	63	4	03.08-05.11	BXW	1,1	ZFR6T-11G	5960	44	
Ibiza 1.4 -/TSi	6J5	1.4	110	4	12.08-01.11	CAVF	0,9	PZFR6R	5758	52	
Ibiza SC 1.4 TSi	6J1	1.4	110	4	01.09-01.11	CAVF	0,9	PZFR6R	5758	52	
Ibiza SC 1.4 Cupra TSi	6J1	1.4	132	4	01.09-01.11	CAVE, CTHE, CTJC	0,9	PZFR6R	5758	52	
Ibiza 1.6 LPG	6J5	1.6	60	4	05.11-05.15	CNKA	1,1	ZFR6T-11G	5960	44	
Ibiza SC 1.6 LPG	6J1	1.6	60	4	05.11-05.15	CNKA	1,1	ZFR6T-11G	5960	44	
Ibiza ST 1.6	6J8	1.6	77	4	02.12-05.15	BTS	1,1	ZFR6T-11G	5960	44	
Ibiza 2.0 -/GTi	6K1	2.0	85	4	02.93-06.99	2E, AGG	0,8	BUR6ET	3172	1	LPG 2
Ibiza 2.0	6L1	2.0	85	4	04.02-11.09	AZL, BBX	1,0	BKUR6ET-10	2397	24	LPG 1
Ibiza 2.0	6J5	2.0	85	4	09.08-05.15	CEKA	1,0	BKUR6ET-10	2397	24	LPG 1

IBIZA 1

Ibiza 1 0.9	021A	0.9	29	4	06.84-09.93	NCA	0,8	BPR6ES	7822	2	LPG 2
Ibiza 1 1.2i	021A	1.2	52	4	08.89-03.93	021C1.000	0,9	BCP7ES	5030		BCPR7EIX
Ibiza 1 1.5	021A	1.5	65	4	04.89-08.91	021D2.000	0,9	BCP7ES	5030		BCPR7EIX
Ibiza 1 1.5i	021A	1.5	66	4	09.87-09.93	021C2.000	0,9	BCP7ES	5030		BCPR7EIX





e kW C
Y
I



Stock-N°

VLINE

LPG/CNG

SEAT

IBIZA 1

Ibiza 1 1.5i SXi	021A	1.5	74	4	06.88-08.91	021B2.000	0,9	BCP7ES	5030		BCPR7EIX
Ibiza 1 1.7	021A	1.7	72	4	01.91-05.93	021A3.000	0,9	BCP7ES	5030		BCPR7EIX

IBIZA 2

Ibiza 2 1.0	6K1	1.0	33	4	03.93-09.96	AAU	0,8	BP5ET	2287		LPG 2
Ibiza 2 1.0	6K1	1.0	37	4	09.96-08.99	AER	0,8	BUR6ET	3172	1	LPG 2
Ibiza 2 1.3	6K1	1.3	40	4	02.93-08.94	AAV	0,8	BP5ET	2287		LPG 2
Ibiza 2 1.3	6K1	1.3	40	4	02.93-08.94	2G	0,8	BP6ET	1263		LPG 2
Ibiza 2 1.4	6K1	1.4	44	4	09.93-12.95	ABD	0,8	BP5ET	2287		LPG 2
Ibiza 2 1.4	6K1	1.4	44	4	09.95-12.97	AEX	0,8	BUR6ET	3172	1	LPG 2
Ibiza 2 1.4	6K1	1.4	44	4	09.97-08.99	AKV	0,8	BUR6ET	3172	1	LPG 2
Ibiza 2 1.4	6K1	1.4	44	4	12.97-05.98	APQ	0,8	BUR6ET	3172	1	LPG 2
Ibiza 2 1.4 16V	6K1	1.4	74	4	06.97-08.99	AFH	0,8	BKUR6ET	6437	27	LPG 1
Ibiza 2 1.6	6K1	1.6	55	4	02.93-07.94	ABU	0,8	BUR6ET	3172	1	LPG 2
Ibiza 2 1.6	6K1	1.6	55	4	09.94-09.97	1F	0,8	BUR5ET	3377	22	LPG 2
Ibiza 2 1.6	6K1	1.6	55	4	05.97-12.98	AEE	0,8	BUR6ET	3172	1	LPG 2
Ibiza 2 1.6	6K1	1.6	55	4	09.97-05.02	ALM	0,8	BUR6ET	3172	1	LPG 2
Ibiza 2 1.6	6K1	1.6	74	4	09.95-05.98	AFT	1,0	BKUR6ET-10	2397	24	LPG 1
Ibiza 2 1.6	6K1	1.6	74	4	01.96-	AEK	0,8	BKUR5ET	2789	29	LPG 1
Ibiza 2 1.8	6K1	1.8	55	4	08.91-	AAM	0,8	BUR5ET	3377	22	LPG 2
Ibiza 2 1.8	6K1	1.8	66	4	02.93-08.94	ABS	0,8	BUR6ET	3172	1	LPG 2
Ibiza 2 1.8	6K1	1.8	66	4	07.94-08.99	ADZ	0,8	BUR6ET	3172	1	LPG 2
Ibiza 2 1.8	6K1	1.8	66	4	03.95-06.99	ACC	0,8	BUR6ET	3172	1	LPG 2
Ibiza 2 1.8 16V	6K1	1.8	95	4	02.94-06.96	ADL	0,8	BKUR7ET	7873		
Ibiza 2 2.0	6K1	2.0	85	4	02.93-06.96	2E	0,8	BUR6ET	3172	1	LPG 2
Ibiza 2 2.0	6K1	2.0	85	4	04.96-08.99	AGG	0,8	BUR6ET	3172	1	LPG 2
Ibiza 2 2.0 16V	6K1	2.0	110	4	07.96-08.99	ABF	1,0	BKUR6ET-10	2397	24	LPG 1

IBIZA 3

Ibiza 3 1.0	6K1	1.0	37	4	08.99-05.02	ALD	1,1	PZFR5D-11	7968	34	LPG 6
Ibiza 3 1.0	6K1	1.0	37	4	08.99-07.00	ANV	1,1	PZFR5D-11	7968	34	LPG 6
Ibiza 3 1.0	6K1	1.0	37	4	07.00-05.02	AUC	1,1	PZFR5D-11	7968	34	LPG 6
Ibiza 3 1.0	6K1	1.0	51	4	05.00-05.02	AVZ	1,0	BKUR5ET-10	7553		LPG 1
Ibiza 3 1.0	6K1	1.0	51	4	06.00-05.02	AST	1,0	BKUR5ET-10	7553		LPG 1
Ibiza 3 1.4	6K1	1.4	44	4	05.99-08.00	ANW	1,1	PZFR5D-11	7968	34	LPG 6
Ibiza 3 1.4	6K1	1.4	44	4	08.99-05.02	AKK	1,1	PZFR5D-11	7968	34	LPG 6
Ibiza 3 1.4	6K1	1.4	44	4	06.00-05.02	AUD	1,1	PZFR5D-11	7968	34	LPG 6
Ibiza 3 1.4 16V	6K1	1.4	55	4	05.98-	AHW	1,0	BKUR6ET-10	2397	24	LPG 1
Ibiza 3 1.4 16V	6K1	1.4	55	4	09.99-06.00	APE	1,0	BKUR6ET-10	2397	24	LPG 1
Ibiza 3 1.4 16V	6K1	1.4	55	4	06.00-05.02	AUA	1,0	BKUR6ET-10	2397	24	LPG 1
Ibiza 3 1.4 16V	6K1	1.4	74	4	09.99-07.00	AQQ	1,0	BKUR6ET-10	2397	24	LPG 1
Ibiza 3 1.4 16V	6K1	1.4	74	4	07.00-05.02	AUB	1,0	BKUR6ET-10	2397	24	LPG 1
Ibiza 3 1.6	6K1	1.6	74	4	05.99-05.02	AEH	1,0	BKUR6ET-10	2397	24	LPG 1
Ibiza 3 1.6	6K1	1.6	74	4	06.99-05.02	AKL	1,0	BKUR6ET-10	2397	24	LPG 1
Ibiza 3 1.6	6K1	1.6	74	4	03.00-02.02	APF	1,0	BKUR6ET-10	2397	24	LPG 1
Ibiza 3 1.6	6K1	1.6	74	4	05.00-05.02	AUR	1,0	BKUR6ET-10	2397	24	LPG 1
Ibiza 3 1.8T 20V Cupra	6K1	1.8	115	5	12.99-02.02	AQX	1,0	BKUR6ET-10	2397	24	LPG 1





l kW C
Y I



Stock-N°

VLINE

LPG/CNG

SEAT

IBIZA 3

Ibiza 3 1.8T 20V Cupra	6K1	1.8	115	5	05.00-05.02	AYP	1,0	BKUR6ET-10	2397	24	LPG 1
------------------------	-----	-----	-----	---	-------------	-----	-----	------------	------	----	-------

IBIZA 4

Ibiza 4 1.2	6L1	1.2	44	3	06.07-05.08	BBM	0,9	ZFR5P-G	6893	41	LPG 6
Ibiza 4 1.2	6L1	1.2	47	3	01.02-06.06	AZQ	0,9	ZFR5P-G	6893	41	LPG 6
Ibiza 4 1.2	6L1	1.2	47	3	05.05-06.06	BME	0,9	ZFR5P-G	6893	41	LPG 6
Ibiza 4 1.2 12V	6L1	1.2	51	3	05.06-11.09	BXV	0,9	ZFR5P-G	6893	41	LPG 6
Ibiza 4 1.4	6L1	1.4	55	4	01.02-04.04	BBY	1,0	BKUR6ET-10	2397	24	LPG 1
Ibiza 4 1.4 Automatic	6L1	1.4	55	4	01.02-04.04	BBY	1,1	PZFR5D-11	7968	34	LPG 6
Ibiza 4 1.4	6L1	1.4	55	4	05.04-06.06	BKY	1,0	BKUR6ET-10	2397	24	LPG 1
Ibiza 4 1.4 Automatic	6L1	1.4	55	4	05.04-06.06	BKY	1,1	PZFR5D-11	7968	34	LPG 6
Ibiza 4 1.4 16V	6L1	1.4	74	4	04.02-11.09	BBZ	1,0	BKUR6ET-10	2397	24	LPG 1
Ibiza 4 1.6	6L1	1.6	74	4	01.07-11.09	BAH	1,1	PZFR5D-11	7968	34	LPG 6
Ibiza 4 1.8T FR	6L1	1.8	110	4	12.03-05.08	BJX, BKV	0,8	PFR6Q	6458	37	LPG 1
Ibiza 4 1.8T Cupra R	6L1	1.8	132	4	05.04-02.08	BBU	0,8	PFR6Q	6458	37	LPG 1
Ibiza 4 1.8T Cupra R	6L1	1.8	132	4	05.04-	BLZ	0,8	PFR6Q	6458	37	LPG 1
Ibiza 4 2.0	6L1	2.0	85	4	07.02-04.04	AZL	1,0	BKUR6ET-10	2397	24	LPG 1
Ibiza 4 2.0	6L1	2.0	85	4	04.03-11.09	BBX	1,0	BKUR6ET-10	2397	24	LPG 1

IBIZA 5

Ibiza 1.0 TGi	KJ1	1.0	66	3	11.17-	DBYA	0,8	PKER7A8DES	97861		
Ibiza 5 1.0 TSi	6P1	1.0	70	3	05.15-	CHZB	0,8	PKER7A8EGS	95463		
Ibiza 5 SC 1.0 TSi	6P5	1.0	70	3	05.15-	CHZB	0,8	PKER7A8EGS	95463		
Ibiza 5 ST 1.0 TSi	6P8	1.0	70	3	05.15-	CHZB	0,8	PKER7A8EGS	95463		
Ibiza 5 1.0 TSi	6P1	1.0	81	3	05.15-	CHZC	0,8	PKER7A8EGS	95463		
Ibiza 5 SC 1.0 TSi	6P5	1.0	81	3	05.15-	CHZC	0,8	PKER7A8EGS	95463		
Ibiza 5 ST 1.0 TSi	6P8	1.0	81	3	05.15-	CHZC	0,8	PKER7A8EGS	95463		
Ibiza 5 1.0 TSi	KJ1	1.0	81	3	08.20-	DLAA	0,8	ILKER7A8EGS	95929		
Ibiza 1.0 TSi	KJ1	1.0	85	3	01.17-	CHZJ, DKJA, DKRF	0,8	IKER7A8EGS	94224		
Ibiza 5 1.2	6J5	1.2	44	3	07.09-	CGPB	1,1	ZFR6T-11G	5960	44	
Ibiza 5 1.2	6J5	1.2	51	3	03.08-	BZG	0,9	ZFR5P-G	6893	41	LPG 6
Ibiza 5 1.2	6J5	1.2	51	3	05.09-	CGPA	0,9	ZFR6T-11G	5960	44	
Ibiza 5 1.2 TSi	6J5	1.2	63	4	08.12-	CBZA	0,7	IZFR6P7	97153		
Ibiza 5 1.2 TSi	6J5	1.2	77	4	09.10-	CBZB	0,7	IZFR6P7	97153		
Ibiza 5 1.4	6J5	1.4	63	4	03.08-	BXW	1,1	ZFR6T-11G	5960	44	
Ibiza 5 1.4	6J5	1.4	63	4	07.08-	CGGB	1,1	ZFR6T-11G	5960	44	
Ibiza 5 1.4 TSi ACT	6J5	1.4	103	4	10.13-	CPTA	0,8	PZKER7B8EGS	93231	55	
Ibiza 5 1.4 TSi	6J5	1.4	110	4	06.09-	CAVF	0,8	SIZFR6B8EG	96209		
Ibiza 5 1.4 TSi	6J5	1.4	110	4	02.12-	CNUB	0,8	SIZFR6B8EG	96209		
Ibiza 5 1.4 TSi Cupra	6J5	1.4	132	4	05.09-	CAVE	0,8	SIZFR6B8EG	96209		
Ibiza 5 1.5 TSi	KJ1	1.5	110	4	07.17-	DADA	0,8	ILKER7A8EGS	95929		
Ibiza 5 1.6 BiFuel	6J5	1.6	60	4	05.11-	CNKA	1,1	ZFR6T-11G	5960	44	
Ibiza 5 1.6	6J5	1.6	77	4	11.06-	BTS	1,1	ZFR6T-11G	5960	44	

INCA

Inca	6K9	1.4	44	4	11.95-12.97	AEX	0,8	BUR6ET	3172	1	LPG 2
Inca	6K9	1.4	44	4	12.97-09.00	AKV	0,8	BUR6ET	3172	1	LPG 2
Inca	6K9	1.4	44	4	12.97-06.03	APQ	0,8	BUR6ET	3172	1	LPG 2





l kW C
Y
I



Stock-Nº

VLINE

LPG/CNG

SEAT

INCA

Inca	6K9	1.4	44	4	09.00-06.03	AUD	1,1	PZFR5D-11	7968	34	LPG 6
Inca 16V	6K9	1.4	55	4	09.00-06.03	AUA	1,0	BKUR6ET-10	2397	24	LPG 1
Inca	6K9	1.6	55	4	11.95-05.97	1F	0,8	BUR5ET	3377	22	LPG 2
Inca	6K9	1.6	55	4	06.97-09.00	AEE	0,8	BUR6ET	3172	1	LPG 2

LEON

Leon 1.4 TSi/TSi ACT	5F1	1.4	110	4	05.14-	CZEA	0,8	PKER7A8EGS	95463		
Leon 1.4 TSi ACT	5F1	1.4	110	4	05.14-	CZEA	0,8	PZKER7B8EGS	93231	55	
Leon 1.6 Multifuel	1P1	1.6	75	4	07.05-08.13	BSE, CCSA, CMXA	1,0	BKUR6ET-10	2397	24	LPG 1
Leon 1.6	1M1	1.6	75	4	10.05-06.06	BFQ	1,0	BKUR6ET-10	2397	24	LPG 1
Leon 2.0 Cupra R TSi	5F1	2.0	228	4	11.17-03.18	CJXG	0,8	PLFER7A8EG	94833		
Leon 2.8 Cupra	1M1	2.8	150	6	05.02-04.04	BDE	1,1	PZFR5D-11	7968	34	LPG 6

LEÓN 1

León 1 1.4 16V	1M1	1.4	55	4	11.99-05.00	APE	1,0	BKUR6ET-10	2397	24	LPG 1
León 1 1.4 16V	1M1	1.4	55	4	01.00-05.02	AHW	1,0	BKUR6ET-10	2397	24	LPG 1
León 1 1.4 16V	1M1	1.4	55	4	06.00-02.02	AXP	1,0	BKUR6ET-10	2397	24	LPG 1
León 1 1.4 16V	1M1	1.4	55	4	.00-	AKQ	1,0	BKUR6ET-10	2397	24	LPG 1
León 1 1.4 16V	1M1	1.4	55	4	02.02-10.05	BCA	1,0	BKUR6ET-10	2397	24	LPG 1
León 1 1.6	1M1	1.6	74	4	10.98-10.05	AKL	1,0	BKUR6ET-10	2397	24	LPG 1
León 1 1.6	1M1	1.6	74	4	11.98-10.05	AEH	1,0	BKUR6ET-10	2397	24	LPG 1
León 1 1.6	1M1	1.6	75	4	10.05-	BFQ	1,0	BKUR6ET-10	2397	24	LPG 1
León 1 1.6 16V	1M1	1.6	77	4	11.99-	ATN	1,0	BKUR6ET-10	2397	24	LPG 1
León 1 1.6 16V	1M1	1.6	77	4	06.00-04.01	AUS	1,0	BKUR6ET-10	2397	24	LPG 1
León 1 1.6 16V	1M1	1.6	77	4	05.01-04.02	AZD	1,1	PZFR6J-11	3586		LPG 6
León 1 1.6 16V	1M1	1.6	77	4	04.02-06.06	BCB	1,1	PZFR5D-11	1664	34	LPG 6
León 1 1.8 20V	1M1	1.8	92	4	10.98-12.03	AGN	1,0	BKUR6ET-10	2397	24	LPG 1
León 1 1.8 20V T	1M1	1.8	132	4	11.99-	APP	0,8	PFR6Q	6458	37	LPG 1
León 1 1.8 20V T4	1M1	1.8	132	4	04.00-	AJQ	0,8	PFR6Q	6458	37	LPG 1
León 1 1.8 20V	1M1	1.8	132	4	06.00-10.05	APG	1,0	BKUR6ET-10	2397	24	LPG 1
León 1 1.8 20V T	1M1	1.8	132	4	09.00-10.05	AUQ	0,8	PFR6Q	6458	37	LPG 1
León 1 1.8 20V T4	1M1	1.8	132	4	09.00-04.04	ARY	0,8	PFR6Q	6458	37	LPG 1
León 1 1.8 20V T	1M1	1.8	132	4	05.01-10.05	AUQ	0,8	PFR6Q	6458	37	LPG 1
León 1 1.8T Cupra R	1M1	1.8	154	4	05.02-05.03	AMK	0,8	PFR6Q	6458	37	LPG 1
León 1 1.8T Cupra R	1M1	1.8	165	4	05.03-	BAM	0,8	PFR6Q	6458	37	LPG 1
León 1 2.8 Cupra 4	1M1	2.8	150	6	05.01-07.01	AUE	1,1	PZFR5D-11	7968	34	LPG 6
León 1 2.8 Cupra 4	1M1	2.8	150	6	06.01-04.04	BDE	1,1	PZFR5D-11	7968	34	LPG 6

LEÓN 2

León 2 1.2 TSi	1P1	1.2	77	4	02.10-	CBZB	0,7	IZFR6P7	97153		
León 2 1.4 16V	1P1	1.4	63	4	06.06-	BXW	1,1	ZFR6T-11G	5960	44	
León 2 1.4 16V	1P1	1.4	63	4	05.10-	CGGB	0,8	SIZFR6B8EG	96209		
León 2 1.4 TFSI	1P1	1.4	92	4	11.07-	CAXC	0,9	PZFR6R	5758	52	
León 2 1.6	1P1	1.6	75	4	07.05-	BSE, BSF	1,0	BKUR6ET-10	2397	24	LPG 1
León 1.6	1P1	1.6	75	4	07.05-12.12	CMXA	1,0	BKUR6ET-10	2397	24	LPG 1
León 1.6 Multifuel	1P1	1.6	75	4	07.05-08.13	CMXA	1,0	BKUR6ET-10	2397	24	LPG 1
León 2 1.6	1P1	1.6	75	4	10.09-	CCSA	1,0	BKUR6ET-10	2397	24	LPG 1
León 2 1.6 LPG	1P1	1.6	75	4	12.09-	CHGA	1,0	BKUR6ET-10	2397	24	LPG 1





e kW C
Y
I



Stock-Nº

VLINE

LPG/CNG

SEAT

LEÓN 2

León 2 1.8 TFSI	1P1	1.8	118	4	05.07-03.09	BZB	0,8	PFR7S8EG	1675	50	PFR8S8EG
León 2 1.8 TFSI	1P1	1.8	118	4	03.09-	CDA	0,8	PFR7S8EG	1675	50	PFR8S8EG
León 2 2.0 FSI	1P1	2.0	110	4	07.05-11.05	BLR, BLY	1,1	PZFR5N-11T	7742		
León 2 2.0 FSI	1P1	2.0	110	4	11.05-03.09	BVY	1,1	PZFR5N-11T	7742		
León 2 2.0 FSI	1P1	2.0	110	4	11.05-	BVZ	1,1	PZFR5N-11T	7742		
León 2 2.0 TFSI	1P1	2.0	136	4	10.05-05.06	BWA1	0,8	PFR7S8EG	1675	50	PFR8S8EG
León 2 2.0 TFSI	1P1	2.0	147	4	05.05-03.09	BWA	0,8	PFR7S8EG	1675	50	PFR8S8EG
León 2 2.0 TFSI	1P1	2.0	155	4	06.09-	CCZB	0,8	PFR7S8EG	1675	50	PFR8S8EG
León 2 2.0 TFSI	1P1	2.0	177	4	11.06-05.09	BWJ	0,8	PFR7S8EG	1675	50	PFR8S8EG
León 2 2.0 TFSI	1P1	2.0	177	4	06.09-	CDLD	0,8	PFR7S8EG	1675	50	PFR8S8EG
León 2 2.0 TSI Cupra R	1P1	2.0	195	4	09.09-	CDLA	0,8	PFR7S8EG	1675	50	PFR8S8EG
León 1 2.3 V5 20V	1M1	2.3	125	5	05.01-11.03	AQN	1,1	PZFR5D-11	7968	34	LPG 6

LEÓN 3

León 1.0 TSi	5F1, 5F8	1.0	85	3	05.15-	CHZD	0,8	IKER7A8EGS	94224		
León 1.0 TSi	5F5	1.0	85	3	05.15-08.18	CHZD	0,8	IKER7A8EGS	94224		
León 3 1.2 TSi	5F1, 5F5, 5F8	1.2	63	4	01.13-	CJZB	0,8	PZKER7B8EGS	93231	55	
León 3 1.2 TSi	5F1, 5F5, 5F8	1.2	77	4	01.13-	CJZA	0,8	PZKER7B8EGS	93231	55	
León 3 1.2 TSi	5F1, 5F5, 5F8	1.2	81	4	04.14-	CYVB	0,8	PZKER7B8EGS	93231	55	
León 1.4 TGi	5F1, 5F8	1.4	81	4	11.13-	CPWA	0,8	PKER7A8DES	97861		
León 3 1.4 TSi	5F1, 5F5, 5F8	1.4	90	4	10.12-	CMBA	0,8	PZKER7B8EGS	93231	55	
León 3 1.4 TSi	5F1, 5F5, 5F8	1.4	92	4	05.14-	CZCA	0,8	PZKER7B8EGS	93231	55	
León 3 1.4 TSi	5F1, 5F5, 5F8	1.4	103	4	09.12-	CHPA, CPTA	0,8	PZKER7B8EGS	93231	55	
León 3 1.4 TSi ACT	5F1, 5F5, 5F8	1.4	110	4	05.14-	CZEA	0,8	PZKER7B8EGS	93231	55	
León 3 1.5 TSi	5F1, 5F8	1.5	96	4	09.18-	DACA, DPBA	0,8	ILKER7A8EGS	95929		
León 3 1.5 TGi	5F1, 5F8	1.5	96	4	10.18-	DHFA	0,8	ILKER7B8DES	90560		
León 3 1.5 TSi	5F1, 5F8	1.5	110	4	07.18-	DADA, DPCA	0,8	ILKER7A8EGS	95929		
León 3 1.8 TSi	5F1, 5F5, 5F8	1.8	132	4	02.13-	CJSA	0,8	PLFER7A8EG	94833		
León 3 2.0 TSi Cupra	5F1, 5F5	2.0	195	4	10.13-	CJXE	0,8	PLFER7A8EG	94833		
León 3 2.0 TSi Cupra	5F1, 5F5	2.0	206	4	10.13-	CJXA	0,8	PLFER7A8EG	94833		
León 2.0 Cupra R TSi	5F1	2.0	228	4	04.18-	CJXG	0,8	ILFER7C8EG	91898		

LEÓN 4

León 4 1.0 TSi	KL1, KL8	1.0	66	3	03.20-	DLAB	0,8	ILKER7A8EGS	95929		
León 4 1.0 TSi	KL1, KL8	1.0	81	3	03.20-	DLAA	0,8	ILKER7A8EGS	95929		
León 4 1.5 TSi	KL1, KL8	1.5	96	4	11.19-	DPBA	0,8	ILKER7A8EGS	95929		
León 4 1.5 TSi	KL1, KL8	1.5	110	4	11.19-	DPCA	0,8	ILKER7A8EGS	95929		
León 4 1.5 eTSi	KL1, KL8	1.5	110	4	11.19-	DFYA	0,8	ILKER7A8EGS	95929		

MARBELLA

Marbella 0.8		0.9	25	4	01.87-12.91	903 08NCA	0,8	BPR6ES	7822	2	LPG 2
Marbella 0.9		0.9	29	4	.86-12.92	09NCA Verg.	0,8	BPR6ES	7822	2	LPG 2
Marbella 0.9		0.9	30	4	.92-05.98	09NCB Cat.	0,9	BPR5ES	7422	6	LPG 2

MII

Mii 1.0	KF1	1.0	44	3	10.11-	CHYA	1,0	ZKER6A-10EG	96596		
Mii 1.0	KF1	1.0	55	3	10.11-	CHYB	1,0	ZKER6A-10EG	96596		





l kW C
Y
I



Stock-N°

VLINE

LPG/CNG

SEAT

RONDA

Ronda 1.2	1.2	44	4	05.84-08.91	O21A.1000	0,9	BCP7ES	5030		BCPR7EIX
Ronda 1.2	1.2	47	4	05.84-08.91	124B6.000	0,8	BPR6ES	7822	2	LPG 2
Ronda 1.5	1.5	63	4	05.84-08.91	O21A.2000	0,9	BCP7ES	5030		BCPR7EIX
Ronda 1.6	1.6	68	4	05.84-08.91	O22A.000	0,8	BP7ES	2412		BPR8EIX

TARRACO

Tarraco 1.5 TSi ACT	KN2	1.5	110	4	09.18-	DADA, DPCA	0,8	ILKER7A8EGS	95929		
Tarraco 2.0 TSi	KN2	2.0	140	4	11.18-	DKZA	0,8	ILFER7C8EG	91898		

TERRA

Terra 0.9	0.9	29	4	09.87-08.91	O9NCA	0,8	BPR6ES	7822	2	LPG 2
Terra 0.9	0.9	29	4	08.91-05.98	O9NCB Cat.	0,9	BPR5ES	7422	6	LPG 2

TOLEDO

Toledo 1.0 TSi	KG3	1.0	70	3	05.17-04.19	CHZB, DKLD	0,8	PKER7A8EGS	95463		
Toledo 1.2 MPI	KG3	1.2	55	3	07.12-06.15	CGPC	1,1	ZFR6T-11G	5960	44	
Toledo 1.4	5P2	1.4	63	4	05.06-05.09	BXW	1,1	ZFR6T-11G	5960	44	
Toledo 1.4 TSi	KG3	1.4	90	4	07.12-06.15	CAXA	0,9	PZFR6R	5758	52	
Toledo 1.4 TFSi	5P2	1.4	92	4	11.07-05.09	CAXC	0,9	PZFR6R	5758	52	
Toledo 1.6	1L2	1.6	52	4	05.91-03.99	1F	0,8	BUR5ET	3377	22	LPG 2
Toledo 1.6 MPI	KG3	1.6	77	4	07.12-06.15	CFNA	1,1	ZFR6T-11G	5960	44	
Toledo 2.0	1L2	2.0	110	4	03.94-03.99	ABF	0,8	PFR7Q	7963		

TOLEDO 1

Toledo 1 1.6	1L	1.6	52	4	11.93-10.99	ABN	1,0	BP5ET-10	5156		LPG 2
Toledo 1 1.6	1L	1.6	54	4	08.91-10.99	EZ	1,0	BP5ET-10	5156		LPG 2
Toledo 1 1.6	1L	1.6	55	4	03.93-	ABU	0,8	BUR6ET	3172	1	LPG 2
Toledo 1 1.6	1L	1.6	55	4	11.93-03.99	1F	0,8	BUR5ET	3377	22	LPG 2
Toledo 1 1.6	1L	1.6	74	4	04.96-03.99	AFT	1,0	BKUR6ET-10	2397	24	LPG 1
Toledo 1 1.8	1L	1.8	66	4	05.91-07.94	ABS	0,8	BUR6ET	3172	1	LPG 2
Toledo 1 1.8	1L	1.8	66	4	08.91-12.92	RP	0,8	BUR6ET	3172	1	LPG 2
Toledo 1 1.8	1L	1.8	66	4	11.94-05.99	ADZ	0,8	BUR6ET	3172	1	LPG 2
Toledo 1 1.8	1L	1.8	66	4	01.95-	ACC	0,8	BUR6ET	3172	1	LPG 2
Toledo 1 1.8 16V	1L	1.8	92	4	08.91-05.94	PL	0,8	BKUR7ET	7873		
Toledo 1 1.8 16V	1L	1.8	98	4	08.91-	KR	0,9	BCPR7ET	2164		BCPR7EIX
Toledo 1 2.0	1L	2.0	85	4	05.91-	2E	0,8	BUR6ET	3172	1	LPG 2
Toledo 1 2.0	1L	2.0	85	4	07.95-03.99	AGG	0,8	BUR6ET	3172	1	LPG 2
Toledo 1 2.0 16V	1L	2.0	110	4	05.94-03.99	ABF	1,0	BKUR6ET-10	2397	24	LPG 1

TOLEDO 2

Toledo 2 1.4 16V	1M2	1.4	55	4	11.99-	APE	1,0	BKUR6ET-10	2397	24	LPG 1
Toledo 2 1.4 16V	1M2	1.4	55	4	01.00-05.02	AHW	1,0	BKUR6ET-10	2397	24	LPG 1
Toledo 2 1.4 16V	1M2	1.4	55	4	06.00-	AXP	1,0	BKUR6ET-10	2397	24	LPG 1
Toledo 2 1.4 16V	1M2	1.4	55	4	.00-	AKQ	1,0	BKUR6ET-10	2397	24	LPG 1
Toledo 2 1.4 16V	1M2	1.4	55	4	02.02-10.05	BCA	1,0	BKUR6ET-10	2397	24	LPG 1
Toledo 2 1.6	1M2	1.6	74	4	01.96- .03	AEK	0,8	BKUR5ET	2789	29	LPG 1
Toledo 2 1.6	1M2	1.6	74	4	11.98-10.05	AEH	1,0	BKUR6ET-10	2397	24	LPG 1
Toledo 2 1.6	1M2	1.6	74	4	02.99-10.05	AKL	1,0	BKUR6ET-10	2397	24	LPG 1
Toledo 2 1.6	1M2	1.6	74	4	09.99-	APF	1,0	BKUR6ET-10	2397	24	LPG 1
Toledo 2 1.6	1M2	1.6	75	4	10.05-	BFQ	1,0	BKUR6ET-10	2397	24	LPG 1





l kW C
Y
I



Stock-N°

VLINE

LPG/CNG

SEAT

TOLEDO 2

Toledo 2 1.6	1M2	1.6	77	4	11.99-	ATN	1,0	BKUR6ET-10	2397	24	LPG 1
Toledo 2 1.6 16V	1M2	1.6	77	4	06.00-	AUS	1,0	BKUR6ET-10	2397	24	LPG 1
Toledo 2 1.6 16V	1M2	1.6	77	4	09.00-04.02	AZD	1,0	BKUR6ET-10	2397	24	LPG 1
Toledo 2 1.6 16V	1M2	1.6	77	4	04.02-05.06	BCB	1,1	PZFR5D-11	1664	34	LPG 6
Toledo 2 1.8 20V	1M2	1.8	92	4	10.98-12.03	AGN	1,0	BKUR6ET-10	2397	24	LPG 1
Toledo 2 1.8 20V	1M2	1.8	92	4	09.00-10.05	APG	1,0	BKUR6ET-10	2397	24	LPG 1
Toledo 2 1.8 20V T	1M2	1.8	132	4	11.99-	APP	0,8	PFR6Q	6458	37	LPG 1
Toledo 2 1.8 20V T	1M2	1.8	132	4	03.00-01.01	AJQ	0,8	PFR6Q	6458	37	LPG 1
Toledo 2 1.8 20V T	1M2	1.8	132	4	05.01-04.04	ARY	0,8	PFR6Q	6458	37	LPG 1
Toledo 2 1.8 20V T	1M2	1.8	132	4	05.01-10.05	AUQ	0,8	PFR6Q	6458	37	LPG 1
Toledo 2 1.8 20V Cupra R	1M2	1.8	154	4	05.02-05.03	AMK	0,8	PFR6Q	6458	37	LPG 1
Toledo 2 1.8 20V Cupra R	1M2	1.8	165	4	05.03-	BAM	0,8	PFR6Q	6458	37	LPG 1
Toledo 2 2.0	1M2	2.0	85	4	06.99-	AQY	1,0	BKUR6ET-10	2397	24	LPG 1
Toledo 2 2.3 V5	1M2	2.3	110	5	10.98-11.00	AGZ	0,6	BKR5EKUP	2890		
Toledo 2 2.3 V5 20V	1M2	2.3	125	5	09.00-11.03	AQN	1,1	PZFR5D-11	7968	34	LPG 6
Toledo 2 2.8 V6	1M2	2.8	150	6	05.01-	AUE	1,1	PZFR5D-11	7968	34	LPG 6
Toledo 2 2.8 V6	1M2	2.8	150	6	05.02-04.04	BDE	1,1	PZFR5D-11	7968	34	LPG 6

TOLEDO 3

Toledo 3 1.6	5P2	1.4	63	4	05.06-05.09	BXW	1,1	ZFR6T-11G	5960	44	
Toledo 3 1.4 TFSI	5P2	1.4	92	4	11.07-05.09	CAXC	0,9	PZFR6R	5758	52	
Toledo 3 1.6	5P2	1.6	75	4	09.04-05.05	BGU	1,0	BKUR6ET-10	2397	24	LPG 1
Toledo 3 1.6	5P2	1.6	75	4	05.05-	BSE	1,0	BKUR6ET-10	2397	24	LPG 1
Toledo 3 1.6	5P2	1.6	75	4	05.05-05.07	BSF	1,0	BKUR6ET-10	2397	24	LPG 1
Toledo 3 1.6	5P2	1.6	75	4	12.07-	CCSA	1,0	BKUR6ET-10	2397	24	LPG 1
Toledo 3 1.8 TFSI	5P2	1.8	118	4	01.07-06.07	BYT	0,8	PFR7S8EG	1675	50	PFR8S8EG
Toledo 3 1.8 TFSI	5P2	1.8	118	4	06.07-03.09	BZB	0,8	PFR7S8EG	1675	50	PFR8S8EG
Toledo 3 1.8 TFSI	5P2	1.8	118	4	03.09-05.09	CDAA	0,8	PFR7S8EG	1675	50	PFR8S8EG
Toledo 3 2.0 FSI	5P2	2.0	110	4	09.04-11.05	BLR	1,1	PZFR5N-11T	7742		
Toledo 3 2.0 FSI	5P2	2.0	110	4	11.04-11.05	BLY	0,9	BKR6E	6962	28	LPG 1
Toledo 3 2.0 FSI	5P2	2.0	110	4	11.05-03.09	BVZ	0,9	BKR6E	6962	28	LPG 1
Toledo 3 2.0 FSI	5P2	2.0	110	4	11.05-03.09	BVY	1,1	PZFR5N-11T	7742		
Toledo 3 2.0 TFSI	5P2	2.0	147	4	11.05-05.09	BWA	0,8	PFR7S8EG	1675	50	PFR8S8EG

TOLEDO 4

Toledo 1.0 TSi	KG3	1.0	81	3	05.17-04.19	CHZC, DKRC	0,8	IKER7A8EGS	94224		
Toledo 4 1.2	KG3	1.2	55	3	10.12-	CGPC	0,9	ZFR6T-11G	5960	44	
Toledo 4 1.2 TSi	KG3	1.2	63	4	10.12-	CBZA	0,7	IZFR6P7	97153		
Toledo 4 1.2 TSi	KG3	1.2	77	4	10.12-	CBZB	0,7	IZFR6P7	97153		
Toledo 4 1.4 TSi (KW<103)	KG3	1.4	90	4	10.12-	CAXA	0,9	PZFR6R	5758	52	
Toledo 4 1.4 TSi (KW>=103)	KG3	1.4	103	4	10.12-	CAXA	0,8	SIZFR6B8EG	96209		

VAN

VAN		1.0	37	4	09.96-	AER	0,8	BUR6ET	3172	1	LPG 2
-----	--	-----	----	---	--------	-----	-----	--------	------	---	-------

SKODA

135

135 LE / LSE		1.3		4	08.89-08.92		0,8	BKR6ES	3783	28	LPG 1
135 LX / GLX		1.3		4	01.93- .96		0,8	BKR6ES	3783	28	LPG 1





el kW C
Y I



Stock-N°

VLINE

LPG/CNG

SKODA

135 FAVORIT

135 Favorit L / LS	1.3		4	04.88- .95		0,8	BCPR5ES	6130	32	LPG 3
135 Favorit LE / LSE	1.3		4	08.89- .95		0,8	BKR6ES	3783	28	LPG 1
135 Favorit LX / GLX	1.3		4	01.93- .95		0,8	BKR6ES	3783	28	LPG 1

135 FORMAN

135 Forman L / LS	1.3		4	08.90- .95		0,8	BCPR5ES	6130	32	LPG 3
135 Forman LE / LSE	1.3		4	02.91- .95		0,8	BKR6ES	3783	28	LPG 1

135 FORMANN

135 Forman LX / GLX	1.3		4	01.93- .95		0,8	BKR6ES	3783	28	LPG 1
---------------------	-----	--	---	------------	--	-----	--------	------	----	-------

CITIGO

Citigo 1.0	NF1, NF2	1.0	44	3	10.11-	CHYA	1,0	ZKER6A-10EG	96596		
Citigo 1.0 G-TEC CNG	NF1, NF2	1.0	50	3	11.12-	CPGA	0,8	PZKER7B8EGS	93231	55	
Citigo 1.0	NF1, NF2	1.0	55	3	10.11-	CHYB	1,0	ZKER6A-10EG	96596		

CUBE

Cube Van 1.6	6U5	1.6	55	4	06.98-12.01	AEE	0,8	BUR6ET	3172	1	LPG 2
--------------	-----	-----	----	---	-------------	-----	-----	--------	------	---	-------

FABIA

Fabia 1.0	6Y2	1.0	37	4	10.00-08.02	AQV, ARV	1,0	BKUR6ET-10	2397	24	LPG 1
Fabia 1.2 (Chassis No 6Y8B451107->; Chassis No 6Y84035537->)	6Y3, 6Y5	1.2	40	3	11.07-12.07	AWY, BMD	1,1	ZFR6T-11G	5960	44	
Fabia 1.2 LPG	542, 545	1.2	44	3	03.09-11.11	CHFA	1,1	ZFR6T-11G	5960	44	
Fabia 1.2 (Chassis No 6Y8B451107->; Chassis No 6Y84035537->)	6Y5	1.2	47	3	11.07-12.07	BME	1,1	ZFR6T-11G	5960	44	
Fabia 1.2 LPG	542	1.2	51	3	01.07-11.14	CGPA	1,1	ZFR6T-11G	5960	44	
Fabia 1.2 LPG	545	1.2	51	3	10.07-11.14	CGPA	1,1	ZFR6T-11G	5960	44	
Fabia 1.4	6Y5	1.4	44	4	04.00-03.03	AZE, AZF	1,0	BKUR5ET-10	7553		LPG 1
Fabia 1.4	6Y5	1.4	50	4	08.99-05.03	AME, AQW, ATZ	1,0	BKUR5ET-10	7553		LPG 1
Fabia 1.4	6Y5	1.4	55	4	10.99-12.07	AUA, BBY	1,1	PZFR5D-11	7968	34	LPG 6
Fabia 1 1.4 16V	6Y2, 6Y5	1.4	55	4	05.04-12.07	BKY	0,9	ZFR5P-G	6893	41	LPG 6
Fabia 1.4	6Y5	1.4	55	4	05.04-12.07	BKY	0,9	ZFR5P-G	6893	41	LPG 6
Fabia 1 1.4	6Y2, 6Y5	1.4	59	4	05.06-12.07	BUD	1,1	ZFR6T-11G	5960	44	
Fabia 1.4 LPG	542	1.4	63	4	01.07-11.14	BXW, CGGB	1,1	ZFR6T-11G	5960	44	
Fabia 1.4 LPG	545	1.4	63	4	10.07-11.14	BXW, CGGB	1,1	ZFR6T-11G	5960	44	

FABIA 1

Fabia 1 1.0	6Y2	1.0	37	4	02.00-	ATY	1,0	BKR6ETA-10	7998		
Fabia 1 1.0	6Y2	1.0	37	4	10.00-08.02	AQV, ARV	1,0	BKR6ETA-10	7998		
Fabia 1 1.2	6Y2, 6Y5	1.2	40	3	07.01-05.04	AWY	0,9	ZFR5P-G	6893	41	LPG 6
Fabia 1 1.2 (VIN->6Y-8B451106; VIN->6Y-84035536)	6Y2, 6Y5	1.2	40	3	05.04-12.07	BMD	0,9	ZFR5P-G	6893	41	LPG 6
Fabia 1 1.2 (VIN 6Y-8B451107->; VIN 6Y-84035537->)	6Y2, 6Y5	1.2	40	3	05.04-12.07	BMD	1,1	ZFR6T-11G	5960	44	
Fabia 1 1.2	6Y2, 6Y5	1.2	47	3	01.03-12.04	AZQ	0,8	PFR6Q	6458	37	LPG 1
Fabia 1 1.2	6Y2, 6Y5	1.2	47	3	01.03-12.04	AZQ	0,9	ZFR5P-G	6893	41	LPG 6
Fabia 1 1.2 (VIN->6Y-8B451106; VIN->6Y-84035536)	6Y2, 6Y5	1.2	47	3	11.04-12.07	BME	0,9	ZFR5P-G	6893	41	LPG 6
Fabia 1 1.2 (VIN 6Y-8B451107->; VIN 6Y-84035537->)	6Y2, 6Y5	1.2	47	3	11.04-12.07	BME	1,1	ZFR6T-11G	5960	44	
Fabia 1 1.4	6Y2, 6Y5	1.4	44	4	04.00-03.03	AZE, AZF	0,8	BKUR5ET-10	7553		LPG 1
Fabia 1 1.4	6Y2, 6Y5	1.4	44	4	04.00-03.03	AZE	0,8	PFR6Q	6458	37	LPG 1
Fabia 1 1.4	6Y2, 6Y5	1.4	50	4	08.99-05.03	AME	1,0	BKUR5ET-10	7553		LPG 1
Fabia 1 1.4	6Y2, 6Y5	1.4	50	4	08.99-01.01	ATZ	1,0	BKUR5ET-10	7553		LPG 1





l kW C
Y
I



Stock-N°

VLINE

LPG/CNG

SKODA

FABIA 1

Fabia 1 1.4	6Y2, 6Y5	1.4	50	4	08.00-05.03	AQW	1,0	BKUR5ET-10	7553		LPG 1
Fabia 1 1.4 16V	6Y2, 6Y5	1.4	55	4	10.99-08.03	AUA	1,0	BKUR6ET-10	2397	24	LPG 1
Fabia 1 1.4 16V Automatic	6Y2, 6Y5	1.4	55	4	10.99-08.03	AUA	1,1	PZFR5D-11	7968	34	LPG 6
Fabia 1 1.4 16V	6Y2, 6Y5	1.4	55	4	04.02-05.04	BBY	1,0	BKUR6ET-10	2397	24	LPG 1
Fabia 1 1.4 16V Automatic	6Y2, 6Y5	1.4	55	4	04.02-05.04	BBY	1,1	PZFR5D-11	7968	34	LPG 6
Fabia 1 1.4 16V	6Y2, 6Y5	1.4	74	4	10.99-08.03	AUB	1,0	BKUR6ET-10	2397	24	LPG 1
Fabia 1 1.4 16V	6Y2, 6Y5	1.4	74	4	05.02-12.07	BBZ	1,0	BKUR6ET-10	2397	24	LPG 1
Fabia 1 2.0	6Y2, 6Y5	2.0	85	4	12.99-12.07	AZL	1,0	BKUR6ET-10	2397	24	LPG 1

FABIA 2

Fabia 2 1.2	542, 545	1.2	44	3	12.06-03.09	BBM	0,9	ZFR5P-G	6893	41	LPG 6
Fabia 2 1.2	542, 545	1.2	44	3	03.09-11.11	CHFA	1,1	ZFR6T-11G	5960	44	
Fabia 2 1.2	542, 545	1.2	44	3	11.11-	CGPB	1,1	ZFR6T-11G	5960	44	
Fabia 2 1.2	542, 545	1.2	51	3	03.09-03.10	CGPA	1,1	ZFR6T-11G	5960	44	
Fabia 2 1.2 (VIN->5J-8B501225; VIN->5J-83074394)	542, 545	1.2	52	3	01.07-05.09	BZG	0,9	ZFR5P-G	6893	41	LPG 6
Fabia 2 1.2 (VIN 5J-8B501226->; VIN 5J-83074395->)	542, 545	1.2	52	3	01.07-05.09	BZG	1,1	ZFR6T-11G	5960	44	
Fabia 2 1.2 (VIN 5J-8B501226->; VIN 5J-83074395->)	542, 545	1.2	52	3	01.08-09.10	CEVA	1,1	ZFR6T-11G	5960	44	
Fabia 2 1.2 TSI	542, 545	1.2	63	4	03.10-	CBZA	0,7	IZFR6P7	97153		
Fabia 2 1.2 TSI	542, 545	1.2	77	4	03.10-	CBZB	0,7	IZFR6P7	97153		
Fabia 2 1.4	542, 545	1.4	63	4	01.07-03.10	BXW	1,1	ZFR6T-11G	5960	44	
Fabia 2 1.4	542, 545	1.4	63	4	03.10-	CGGB	1,1	ZFR6T-11G	5960	44	
Fabia 2 1.4 TSI RS	542, 545	1.4	132	4	05.10-02.11	CAVE	0,9	PZFR6R	5758	52	
Fabia 2 1.4 TSI RS	542, 545	1.4	132	4	05.10-	CTHE	0,8	SIZFR6B8EG	96209		
Fabia 2 1.4 TSI RS	542, 545	1.4	132	4	03.11-	CAVE	0,8	SIZFR6B8EG	96209		
Fabia 2 1.6	542, 545	1.6	77	4	04.07-	BTS	1,1	ZFR6T-11G	5960	44	
Fabia 2 1.6	542, 545	1.6	77	4	06.10-	CFNA	1,1	ZFR6T-11G	5960	44	

FABIA 3

Fabia 3 1.0	NJ3, NJ5	1.0	44	3	10.14-	CHYA	1,0	ZKER6A-10EG	96596		
Fabia 3 1.0	NJ3, NJ5	1.0	55	3	10.14-	CHYB	1,0	ZKER6A-10EG	96596		
Fabia 3 1.2 TSI	NJ3, NJ5	1.2	66	4	10.14-	CJZC	0,8	PZKER7B8EGS	93231	55	
Fabia 3 1.2 TSI	NJ3, NJ5	1.2	81	4	10.14-	CJZD	0,8	PZKER7B8EGS	93231	55	

FELICIA

Felicia		1.0	37	4	08.99-	AHT	1,0	BKR6ETA-10	7998		
Felicia 135i		1.3	40	4	10.94-07.96	Mpi	1,0	BKUR5ET-10	7553		LPG 1
Felicia		1.3	40	4	08.96-08.01	AMG	1,0	BKUR5ET-10	7553		LPG 1
Felicia 135i		1.3	43	4	08.96-	AMJ	0,8	BCPR5ES	6130	32	LPG 3
Felicia 136i		1.3	50	4	10.94-07.96	136B	0,8	BCPR6ES	2330	12	LPG 3
Felicia 136i		1.3	50	4	10.94-07.96	136M	0,8	BKR6ES	3783	28	LPG 1
Felicia		1.3	50	4	08.96-08.01	AMH	1,0	BKUR5ET-10	7553		LPG 1
Felicia		1.6	55	4	05.95-08.01	AEE	0,8	BUR6ET	3172	1	LPG 2

KAMIQ

Kamq 1.0 TSi	NW4	1.0	70	3	07.19-	DKLA	0,8	PKER7A8EGS	95463		
Kamq 1.0 TSi	NW4	1.0	85	3	07.19-	DKRF	0,8	IKER7A8EGS	94224		
Kamq 1.5 TSi	NW4	1.5	110	4	07.19-	DADA, DPCA	0,8	ILKER7A8EGS	95929		





e kW C
Y
I



Stock-N°

VLINE

LPG/CNG

SKODA

KAROQ

Karoq 1.0 TSi	NU7	1.0	85	3	07.17-	CHZJ, DKRF	0,8	IKER7A8EGS	94224		
Karoq 1.5 TSi	NU7	1.5	110	4	07.17-	DADA, DPCA	0,8	ILKER7A8EGS	95929		

KODIAQ

Kodiaq 1.5 TSi	NS7	1.5	110	4	07.18-	DADA, DPCA	0,8	ILKER7A8EGS	95929		
----------------	-----	-----	-----	---	--------	------------	-----	-------------	-------	--	--

OCTAVIA

Octavia 1.4	1U2	1.4	44	4	02.99-03.01	AMD	1,0	BKUR5ET-10	7553		LPG 1
Octavia 1.4	1Z5	1.4	55	4	05.04-05.06	BCA	1,0	BKUR6ET-10	2397	24	LPG 1
Octavia 1.4 TSi	5E3, NL3, NR3, 5E5, 5E6	1.4	110	4	08.14-	CZDA	0,8	PZKER7B8EGS	93231	55	
Octavia 1.6 LPG	1Z3	1.6	75	4	05.05-03.13	BSE, CHGA	1,0	BKUR6ET-10	2397	24	LPG 1
Octavia 1.8	1U2	1.8	110	4	12.97-12.10	AGU	1,0	BKUR6ET-10	2397	24	LPG 1
Octavia 1.8	1U5	1.8	110	4	05.98-12.10	AGU	1,0	BKUR6ET-10	2397	24	LPG 1
Octavia 2.0	1U2	2.0	85	4	05.99-05.07	AZJ	1,1	PZFR5D-11	7968	34	LPG 6

OCTAVIA 1

Octavia 1 1.4	1U2, 1U5	1.4	44	4	02.99-03.01	AMD	1,0	BKUR6ET-10	2397	24	LPG 1
Octavia 1 1.4	1U2, 1U5	1.4	55	4	05.99-	AHW	1,0	BKUR6ET-10	2397	24	LPG 1
Octavia 1 1.4 16V	1U2, 1U5	1.4	55	4	08.00-01.02	AXP	1,0	BKUR6ET-10	2397	24	LPG 1
Octavia 1 1.4 16V Automatik	1U2, 1U5	1.4	55	4	08.00-01.02	AXP	1,1	PZFR5D-11	7968	34	LPG 6
Octavia 1 1.4	1U2, 1U5	1.4	55	4	.00-	AKQ, APE	1,0	BKUR6ET-10	2397	24	LPG 1
Octavia 1 1.4 16V	1U2, 1U5	1.4	55	4	01.02-12.10	BCA	1,0	BKUR6ET-10	2397	24	LPG 1
Octavia 1 1.6	1U2, 1U5	1.6	55	4	10.96-09.04	AEE	0,8	BUR6ET	3172	1	LPG 2
Octavia 1 1.6	1U2, 1U5	1.6	74	4	02.97-12.07	AEH	1,0	BKUR6ET-10	2397	24	LPG 1
Octavia 1 1.6	1U2, 1U5	1.6	74	4	08.98-12.07	AKL	1,0	BKUR6ET-10	2397	24	LPG 1
Octavia 1 1.6	1U2, 1U5	1.6	75	4	08.00-04.02	AVU	1,0	BKUR6ET-10	2397	24	LPG 1
Octavia 1 1.6	1U2, 1U5	1.6	75	4	04.02-12.10	BFQ	1,0	BKUR6ET-10	2397	24	LPG 1
Octavia 1 1.8 20V	1U2, 1U5	1.8	92	4	10.96-07.00	AGN	1,0	BKUR6ET-10	2397	24	LPG 1
Octavia 1 1.8 T	1U2, 1U5	1.8	110	4	05.98-12.10	AGU	0,8	PFR6Q	6458	37	LPG 1
Octavia 1 1.8 T	1U2, 1U5	1.8	110	4	.98-	AEB	0,8	PFR6Q	6458	37	LPG 1
Octavia 1 1.8 T	1U2, 1U5	1.8	110	4	01.00-07.00	ARZ	0,8	PFR6Q	6458	37	LPG 1
Octavia 1 1.8 T	1U2, 1U5	1.8	110	4	08.00-05.06	ARX	0,8	PFR6Q	6458	37	LPG 1
Octavia 1 1.8 T	1U2, 1U5	1.8	110	4	08.00-12.10	AUM	0,8	PFR6Q	6458	37	LPG 1
Octavia 1 1.8 T RS	1U2, 1U5	1.8	132	4	12.00-01.06	AUQ	0,8	PFR6Q	6458	37	LPG 1
Octavia 1 2.0	1U2, 1U5	2.0	85	4	05.99-05.07	APK	1,0	BKUR6ET-10	2397	24	LPG 1
Octavia 1 2.0	1U2, 1U5	2.0	85	4	05.99-03.02	AQY	1,0	BKUR6ET-10	2397	24	LPG 1
Octavia 1 2.0	1U2, 1U5	2.0	85	4	11.99-09.04	AZH	1,0	BKUR6ET-10	2397	24	LPG 1
Octavia 1 2.0	1U2, 1U5	2.0	85	4	09.00-01.05	AEG	1,0	BKUR6ET-10	2397	24	LPG 1
Octavia 1 2.0	1U5	2.0	85	4	03.02-01.06	AZJ	1,1	PZFR5D-11	7968	34	LPG 6
Octavia 1 2.0 4x4	1U5	2.0	88	4	11.99-04.01	ATF	1,1	PZFR5D-11	7968	34	LPG 6

OCTAVIA 2

Octavia 2 1.2 TSI	1Z3, 1Z5	1.2	77	4	02.10-	CBZB	0,7	IZFR6P7	97153		
Octavia 2 1.4	1Z3, 1Z5	1.4	55	4	05.04-05.06	BCA	1,0	BKUR6ET-10	2397	24	LPG 1
Octavia 2 1.4	1Z3, 1Z5	1.4	59	4	05.06-	BUD	1,1	ZFR6T-11G	5960	44	
Octavia 2 1.4 TSI (KW<103)	1Z3, 1Z5	1.4	90	4	11.08-	CAXA	0,9	PZFR6R	5758	52	
Octavia 2 1.4 TSI (KW>=103)	1Z3, 1Z5	1.4	103	4	11.08-	CAXA	0,8	SIZFR6B8EG	96209		
Octavia 2 1.6	1Z3, 1Z5	1.6	75	4	05.04-05.05	BGU	1,0	BKUR6ET-10	2397	24	LPG 1





el kW C
Y
I



Stock-N°

VLINE

LPG/CNG

SKODA

OCTAVIA 2

Octavia 2 1.6	1Z3, 1Z5	1.6	75	4	05.05-	BSE	1,0	BKUR6ET-10	2397	24	LPG 1
Octavia 2 1.6	1Z3, 1Z5	1.6	75	4	11.07-05.10	CCSA	1,0	BKUR6ET-10	2397	24	LPG 1
Octavia 2 1.6 LPG	1Z3, 1Z5	1.6	75	4	08.09-	CHGA	1,0	BKUR6ET-10	2397	24	LPG 1
Octavia 2 1.6	1Z3, 1Z5	1.6	75	4	05.10-	CMXA	1,0	BKUR6ET-10	2397	24	LPG 1
Octavia 2 1.6 FSI	1Z3, 1Z5	1.6	85	4	02.04-10.08	BLF	0,5	ZFR6S-Q	6449		
Octavia 2 1.8 TSI 4x4	1Z5	1.8	112	4	03.09-	CDAB	0,8	PFR7S8EG	1675	50	PFR8S8EG
Octavia 2 1.8 TSI	1Z3, 1Z5	1.8	118	4	06.07-10.08	BZB	0,8	PFR7S8EG	1675	50	PFR8S8EG
Octavia 2 1.8 TSI	1Z3, 1Z5	1.8	118	4	11.08-	CDA	0,8	PFR7S8EG	1675	50	PFR8S8EG
Octavia 2 2.0 FSI	1Z3, 1Z5	2.0	110	4	11.04-11.05	BLY	0,9	BKR6E	6962	28	LPG 1
Octavia 2 2.0 FSI	1Z3, 1Z5	2.0	110	4	11.04-11.05	BLR	1,1	PZFR5N-11T	7742		
Octavia 2 2.0 FSI 4x4	1Z5	2.0	110	4	11.04-11.05	BLX	1,1	PZFR5N-11T	7742		
Octavia 2 2.0 FSI	1Z3, 1Z5	2.0	110	4	11.05-10.08	BVZ	0,9	BKR6E	6962	28	LPG 1
Octavia 2 2.0 FSI	1Z3, 1Z5	2.0	110	4	11.05-10.08	BVY	1,1	PZFR5N-11T	7742		
Octavia 2 2.0 FSI 4x4	1Z5	2.0	110	4	11.05-10.08	BVX	1,1	PZFR5N-11T	7742		
Octavia 2 2.0 TSI RS	1Z3, 1Z5	2.0	147	4	10.05-10.08	BWA	0,8	PFR7S8EG	1675	50	PFR8S8EG
Octavia 2 2.0 TSI RS	1Z3, 1Z5	2.0	147	4	11.08-	CCZA	0,8	PFR7S8EG	1675	50	PFR8S8EG

OCTAVIA 3

Octavia 1.0 TSi	5E5, 5E6	1.0	85	3	05.16-	DKRF	0,8	IKER7A8EGS	94224		
Octavia 1.0 TSi	5E3, NL3, NR3, 5E5, 5E6	1.0	85	3	05.16-	CHZD, DKRA	0,8	IKER7A8EGS	94224		
Octavia 3 1.2 TSi	5E3, 5E5	1.2	63	4	11.12-	CJZB	0,8	PZKER7B8EGS	93231	55	
Octavia 3 1.2 TSi	5E3, 5E5	1.2	77	4	11.12-	CJZA	0,8	PZKER7B8EGS	93231	55	
Octavia 1.4 TSi G-TEC	5E3, 5E5	1.4	81	4	11.12-	CPWA	0,8	PKER7A8DES	97861		
Octavia 3 1.4 TSi	5E3, 5E5	1.4	103	4	11.12-	CHPA	0,8	PZKER7B8EGS	93231	55	
Octavia 3 1.8 TSi	5E3, 5E5	1.8	132	4	11.12-	CJSA, CJSB	0,8	PLFER7A8EG	94833		
Octavia 2.0 TSi (For OE-No. 06K905601L; Euro 6)	5E3, 5E5	2.0	140	4	02.17-	DKZA	0,8	ILFER7C8EG	91898		
Octavia 3 2.0 TSi RS	5E3, 5E5	2.0	162	4	06.13-	CHHB	0,8	PLFER7A8EG	94833		

OCTAVIA 4

Octavia 4 1.5 TSi G-TEC	5E5	1.5	96	4	01.19-	DHFA	0,8	ILKER7B8DES	90560		
Octavia 4 1.5 TSi	5E3, 5E5, 5E6	1.5	110	4	02.17-	DADA	0,8	ILKER7A8EGS	95929		

OCTAVIA 5

Octavia 5 1.5 TSi	NX3, NX5	1.5	110	4	11.19-	DPCA	0,8	ILKER7A8EGS	95929		
-------------------	----------	-----	-----	---	--------	------	-----	-------------	-------	--	--

RAPID

Rapid 1.0 TSi	NH1, NH3	1.0	81	3	06.17-12.19	CHZC	0,8	IKER7A8EGS	94224		
Rapid 1.2 LPG	NH3	1.2	55	3	07.12-06.15	CGPC	1,1	ZFR6T-11G	5960	44	
Rapid Spaceback 1.2 LPG	NH1	1.2	55	3	07.12-06.15	CGPC	1,1	ZFR6T-11G	5960	44	
Rapid Spaceback 1.2 MPi	NH1	1.2	55	3	07.12-06.15	CGPC	1,1	ZFR6T-11G	5960	44	
Rapid 1.6 MPi	NH3, NK3	1.6	77	4	07.12-06.15	CFNA	1,1	ZFR6T-11G	5960	44	
Rapid Spaceback 1.6 MPi	NH1	1.6	77	4	07.12-06.15	CFNA	1,1	ZFR6T-11G	5960	44	

RAPID 2012

Rapid 1.2	NH1, NH3	1.2	55	3	07.12-	CGPC	1,1	ZFR6T-11G	5960	44	
Rapid 1.2 TSi	NH1, NH3	1.2	63	4	07.12-	CBZA	0,7	IZFR6P7	97153		
Rapid 1.2 TSi	NH1, NH3	1.2	77	4	07.12-	CBZB	0,7	IZFR6P7	97153		
Rapid 1.4 TSi (KW<103)	NH1, NH3	1.4	90	4	07.12-	CAXA	0,9	PZFR6R	5758	52	
Rapid 1.4 TSi (KW>=103)	NH1, NH3	1.4	103	4	07.12-	CAXA	0,8	SIZFR6B8EG	96209		





e kW C Y I



Stock-N°

VLINE

LPG/CNG

SKODA**ROOMSTER**

Roomster (VIN→5J-8B600480; VIN→5J-85036340)	5J	1.2	47	3	05.06-01.07	BME	0,9	ZFR5P-G	6893	41	LPG 6
Roomster (VIN 5J-8B600481→; VIN 5J-85036341→)	5J	1.2	47	3	05.06-01.07	BME	1,1	ZFR6T-11G	5960	44	
Roomster 1.2	5J7	1.2	47	3	05.06-01.07	BME	1,1	ZFR6T-11G	5960	44	
Roomster	5J	1.2	51	3	03.09-	CGPA	1,1	ZFR6T-11G	5960	44	
Roomster 1.2 LPG	5J7	1.2	51	3	03.09-05.15	CGPA	1,1	ZFR6T-11G	5960	44	
Roomster (VIN→5J-8B600480; VIN→5J-85036340)	5J	1.2	52	3	01.07-03.09	BZG	0,9	ZFR5P-G	6893	41	LPG 6
Roomster (VIN 5J-8B600481→; VIN 5J-85036341→)	5J	1.2	52	3	01.07-03.09	BZG	1,1	ZFR6T-11G	5960	44	
Roomster 1.2 TSI	5J	1.2	63	4	03.10-	CBZA	0,7	IZFR6P7	97153		
Roomster 1.2 TSI	5J	1.2	77	4	03.10-	CBZB	0,7	IZFR6P7	97153		
Roomster	5J	1.4	63	4	05.06-	BXW	1,1	ZFR6T-11G	5960	44	
Roomster 1.4 LPG	5J7	1.4	63	4	05.06-05.15	BXW, CGGB	1,1	ZFR6T-11G	5960	44	
Roomster	5J	1.4	63	4	03.10-	CGGB	1,1	ZFR6T-11G	5960	44	
Roomster Scout 1.4 LPG	5J7	1.4	63	4	03.10-05.15	CGGB	1,1	ZFR6T-11G	5960	44	
Roomster	5J	1.6	77	4	05.06-	BTS	1,1	ZFR6T-11G	5960	44	
Roomster 1.6 LPG	5J7	1.6	77	4	06.06-07.10	BTS	1,1	ZFR6T-11G	5960	44	
Roomster	5J	1.6	77	4	06.10-	CFNA	1,1	ZFR6T-11G	5960	44	

SCALA

Scala 1.0 TSi	NW1	1.0	70	3	02.19-	DKLA	0,8	PKER7A8EGS	95463		
Scala 1.0 TSi	NW1	1.0	85	3	02.19-	DKRF	0,8	IKER7A8EGS	94224		
Scala 1.5 TSi	NW1	1.5	110	4	02.19-	DADA, DPCA	0,8	ILKER7A8EGS	95929		

SUPERB

Superb 1.4 TSi ACT IV	3V3, 3V5	1.4	115	4	08.19-	DGEB	0,8	PKER7A8EGS	95463		
Superb 2.8	3U4	2.8	140	6	06.02-04.08	BBG	0,5	BKR6EKUB	3584		LPG 1

SUPERB 1

Superb 1 1.8 Turbo	3U4	1.8	110	4	10.01-03.08	AWT	0,8	PFR6Q	6458	37	LPG 1
Superb 1 2.0	3U4	2.0	85	4	12.01-03.08	AZM	1,0	BKUR6ET-10	2397	24	LPG 1
Superb 1 2.8 V6	3U4	2.8	140	6	05.02-03.08	BBG	0,5	BKR6EKUB	3584		LPG 1
Superb 1 2.8 V6	3U4	2.8	142	6	12.01-03.08	AMX	0,5	BKR6EKUB	3584		LPG 1

SUPERB 2

Superb 2 1.4 TSi	3T4, 3T5	1.4	92	4	08.08-	CAXC	0,9	PZFR6R	5758	52	
Superb 2 1.8 TSi	3T4, 3T5	1.8	112	4	03.09-	CDAB	0,8	PFR7S8EG	1675	50	PFR8S8EG
Superb 2 1.8 TSi	3T4, 3T5	1.8	118	4	03.08-05.09	BZB	0,8	PFR7S8EG	1675	50	PFR8S8EG
Superb 2 1.8 TSi	3T4, 3T5	1.8	118	4	09.08-	CDAA	0,8	PFR7S8EG	1675	50	PFR8S8EG
Superb 2 2.0 TSi	3T4, 3T5	2.0	147	4	05.10-	CCZA	0,8	PFR7S8EG	1675	50	PFR8S8EG
Superb 2 3.6 V6 4x4	3T4, 3T5	3.6	191	6	09.08-	CDVA	0,8	ILZKR8A	94290		

SUPERB 3

Superb 3 1.5 TSi	3V3, 3V5	1.5	110	4	03.15-	DADA	0,8	ILKER7A8EGS	95929		
Superb 3 2.0 TFSi	3V3, 3V5	2.0	200	4	03.15-	DNUA	0,8	ILKER7A8EGS	95929		

YETI (5L)

Yeti 1.2 TSi	5L	1.2	77	4	09.09-	CBZB	0,7	IZFR6P7	97153		
Yeti 1.4 TSi (KW<103)	5L	1.4	90	4	06.10-	CAXA	0,9	PZFR6R	5758	52	
Yeti 1.4 TSi (KW>=103)	5L	1.4	103	4	06.10-	CAXA	0,8	SIZFR6B8EG	96209		
Yeti 1.8 TSi 4x4	5L	1.8	112	4	11.09-	CDAB	0,8	PFR7S8EG	1675	50	PFR8S8EG
Yeti 1.8 TSi 4x4	5L	1.8	118	4	05.09-	CDAA	0,8	PFR7S8EG	1675	50	PFR8S8EG





l kW C
Y I



Stock-N°

VLINE

LPG/CNG

SMART

FORTWO A450

Fortwo Cabrio 0.6 (Euro 3)	450441, 450442, 450443, 450452	0.6	45	3	01.04-12.06		0,65	BKR6EKE	5649		
----------------------------	---	-----	----	---	-------------	--	------	---------	------	--	--

FORTWO C450

Fortwo Coupe 0.6	450332, 450336, 450341, 450342, 450343, 450346, 450347, 450352, 450353	0.6	45	3	01.04-02.07		0,65	BKR6EKE	5649		
Fortwo Coupe 0.7	450335	0.7	40	3	01.04-01.07		0,6	LKR8A	5214		

SMART

Smart (Twin Spark)	450	0.6	33	3	10.98-01.04	M 160 ...	0,65	BKR6EKE	5649		
Smart (Twin Spark)	450	0.6	40	3	10.98-01.04	M 160 ...	0,65	BKR6EKE	5649		
Smart Crossblade (Twin Spark)	450	0.6	52	3	10.02-01.04	M 160 ...	0,65	BKR6EKE	5649		
Smart (Twin Spark)	450	0.7	37	3	10.02-01.04	M 160/1	0,6	LKR8A	5214		
Smart fortwo (Twin Spark)	450	0.7	37	3	01.04-01.07	M 160/1	0,6	LKR8A	5214		
Smart fortwo (Twin Spark)	450	0.7	45	3	01.04-01.07	M 160/1	0,6	LKR8A	5214		
Smart (Twin Spark)	450	0.7	60	3	10.02-01.04	M 160/1	0,6	LKR8A	5214		

SMART 451

Smart fortwo Brabus	451	0.7	55	3	01.04-10.07		0,8	ILZFR6C-K	6645		
Smart fortwo 2	451	1.0	45	3	03.07-12.10	M 132.910	0,9	LKR7B-9	5847		
Smart fortwo 2	451	1.0	52	3	03.07-12.10	M 132.910	0,9	LKR7B-9	5847		
Smart fortwo 2 Turbo	451	1.0	62	3	03.07-12.10	M 132.930	0,9	LKR7B-9	5847		
Smart fortwo Brabus	451	1.0	72	3	01.08-12.10	M 132.930	0,9	LKR7B-9	5847		

SMART 452

Smart Roadster (Twin Spark)	452	0.7	45	3	10.02-11.05	M 160/1	0,6	LKR8A	5214		
Smart Roadster (Twin Spark)	452	0.7	60	3	06.03-11.05	M 160/1	0,6	LKR8A	5214		
Smart Roadster Brabus (Twin Spark)	452	0.7	74	3	12.03-11.05	M 160/1	0,6	LKR8A	5214		

SMART 454

Smart fourfour 1	454	1.1	55	3	01.04-06.06	M 134.910	1,1	LFR6C-11	5788	48	
Smart fourfour 1	454	1.3	70	4	01.04-06.06	M 135.930	1,1	LFR6C-11	5788	48	
Smart fourfour 1	454	1.5	80	4	01.04-06.06	M 135.950	1,1	LFR6C-11	5788	48	
Smart fourfour 1 Brabus	454	1.5	130	4	05.05-06.06	M 122.950	0,8	ILZFR6C-K	6645		

SSANGYONG

CHAIRMAN

Chairman	P19	3.2	165	6	06.07-	M162E32	1,0	BKUR5ETZ-10	91926		
----------	-----	-----	-----	---	--------	---------	-----	-------------	-------	--	--

KORANDO

Korando 2.0		2.0	100	4	07.96-	M161E20 M111.940	0,8	BCP5ES	7496	16	LPG 3
Korando 2.3		2.3	110	4	09.96-02.99	M161E23 M111.970	0,8	BCP5ES	7496	16	LPG 3
Korando 3.2		3.2	162	6	09.96-03.00	M162E32 M104...	0,8	BCP5ES	7496	16	LPG 3
Korando 3.2 LPG		3.2	162	6	07.97-03.00		0,8	BKR5EIX	6341		LPG 1

KYRON

Kyron 3.2	S09	3.2	162	6	05.06-	G32D	1,0	BKUR5ETZ-10	91926		
Kyron 3.2		3.2	162	6	03.08-	G32D	0,8	BCP5ES	7496	16	LPG 3





e kW C
Y
I



Stock-N°

VLINE

LPG/CNG

SSANGYONG

MUSSO

Musso 2.0	2.0	100	4	05.96-	M161E20 M111.940	0,8	BCP5ES	7496	16	LPG 3
Musso 2.3	2.3	110	4	05.96-02.99	M161E23 M111.970	0,8	BCP5ES	7496	16	LPG 3
Musso 3.2	3.2	162	6	01.96-	M162E32 M104...	0,8	BCP5ES	7496	16	LPG 3

REXTON

Rexton RX 230 4x4	2.3	110	4	05.02-08.06	G23D	0,8	BCP5ES	7496	16	LPG 3
Rexton RX 320s	3.2	162	6	04.02-08.06	G32D	0,8	BCP5ES	7496	16	LPG 3
Rexton 3.2 RX320	PO9	3.2	162	6	05.04-08.06	G32D	1,0	BKUR5ETZ-10	91926	

RODIUS

Rodius 3.2	3.2	162	6	05.05-12.12	M162E32	1,0	BKUR5ETZ-10	91926		
Rodius 3.2	3.2	162	6	07.07-	G32D	0,8	BCP5ES	7496	16	LPG 3
Rodius 3.2	3.2	162	6	07.07-12.12	M162E32	1,0	BKUR5ETZ-10	91926		

RODIUS II

Rodius 3.2	CA1	3.2	162	6	06.12-	G32D	1,0	BKUR5ETZ-10	91926	
------------	-----	-----	-----	---	--------	------	-----	-------------	-------	--

STEYR

650 TR

650 TR	0.66	29	2	.66-		0,7	B8HS	5510		
--------	------	----	---	------	--	-----	------	------	--	--

SUBARU

FORESTER

Forester 2.0	S10SF	2.0	90	4	08.97-09.02	EJ20J	1,1	BKR6ES-11	5553		LPG 1
Forester		2.0	90	4	09.97- .02	EJ20J	1,1	BCPR6ES-11	7121	11	LPG 3
Forester		2.0	92	4	09.97-	EJ20	1,1	BKR6E-11	2756	14	LPG 1
Forester 2.0	S10SF	2.0	92	4	09.98-05.02	EJ202	1,1	BKR6ES-11	5553		LPG 1
Forester 2.0	S11SG	2.0	92	4	06.02-05.05	EJ201	1,1	BKR6ES-11	5553		LPG 1
Forester		2.0	110	4	01.08-	EJ204	1,1	SILFR6A11	5468		
Forester 2.0 BiFuel	S12SH	2.0	110	4	01.09-12.11	EJ204	1,1	SILFR6A11	5468		
Forester 2.0	S12SH	2.0	110	4	01.10-09.13	FB20B	1,1	SILZKAR7B11	93482		
Forester 2.0 X	SJ13	2.0	110	4	08.12-	FB20A, FB20B	1,1	SILZKAR7B11	93482		
Forester 2.0	S11SG	2.0	116	4	06.05-05.08	EJ201	1,1	BKR6ES-11	5553		LPG 1
Forester		2.0	116	4	09.05-02.08	EJ20	0,8	ILFR6B	6481		
Forester		2.0	116	4	03.08-	EJ20	0,8	ILFR6B	6481		
Forester 2.0	S10SF	2.0	125	4	09.98-08.00	EJ205	0,9	PFR6B	3500		LPG 1
Forester 2.0 Turbo		2.0	130	4	03.99- .02	EJ20	0,9	PFR6B	3500		LPG 1
Forester 2.0	S10SF	2.0	130	4	10.00-05.02	EJ205	0,8	PFR6G	4793		PFR7G
Forester 2.0	S13	2.0	177	4	08.12-	FA20E, FA20F	0,6	ILKAR8H6	96024		
Forester 2.5	S11SG	2.5	115	4	11.02-12.08	EJ251, EJ253	1,1	BKR6ES-11	5553		LPG 1
Forester 2.5	S12SH	2.5	126	4	06.08-09.13	EJ253	1,1	PFR5B-11	2300		PFR6B
Forester 2.5 Turbo		2.5	155	4	.05-	EJ25	0,8	PFR6G	4793		PFR7G
Forester		2.5	169	4	.06-02.08	EJ25	0,8	ILFR6B	6481		
Forester		2.5	169	4	06.08-	EJ255	0,8	ILFR6B	6481		
Forester 2.5	S12SH	2.5	169	4	06.08-09.13	EJ255	0,8	SILFR6A	7913		
Forester 2.5 Prodrive Performance Pack	S11SG	2.5	188	4	05.05-09.05	EJ255	0,8	ILFR6B	6481		

IMPREZA

Impreza 1.5	G11GD	1.5	74	4	06.01-09.05	EL154	0,8	ILFR6B	6481		
Impreza 1.5R		1.5	79	4	09.07-	EJ15	0,8	ILFR6B	6481		





l kW C
Y
I



Stock-N°

VLINE

LPG/CNG

SUBARU

IMPREZA

Impreza 1.5	G12GE	1.5	79	4	09.07-03.12	EL154		1,1	DILFR6D11	6176		
Impreza 1.5	G12GE	1.5	79	4	02.08-03.12	EL154		1,1	DILFR6D11	6176		
Impreza 1.5 BiFuel	G12GH	1.5	79	4	01.10-03.12	EL154		1,1	DILFR6D11	6176		
Impreza 1.5	G11GD	1.5	81	4	10.05-03.07	EL154		0,8	ILFR6B	6481		
Impreza 1.6		1.6	66	4	.93- .00	EJ16		1,1	BKR6E-11	2756	14	LPG 1
Impreza 1.6	G11GD	1.6	70	4	10.00-09.06	EJ161		1,1	BKR6E-11	2756	14	LPG 1
Impreza Estate/Wagon Plus 1.6	G11GG	1.6	70	4	10.00-09.06	EJ161		1,1	BKR6E-11	2756	14	LPG 1
Impreza		1.6	70	4	12.00- .03	EJ16		1,1	BKR6E-11	2756	14	LPG 1
Impreza		1.6	70	4	.03- .06	EJ16		0,8	PFR6G	4793		PFR7G
SUBARU Impreza 1.6	GT3	1.6	84	4	07.17-	FB16A		1,1	DILZKAR7B11	90935		
SUBARU Impreza 1.6	GT2, GT3	1.6	85	4	10.16-	FB16A		1,1	DILZKAR7B11	90935		
Impreza 1.8		1.8	76	4	.93- .00	EJ18		1,1	BKR6E-11	2756	14	LPG 1
Impreza 2.0	G11GD	2.0	92	4	10.00-09.06	EJ201		1,1	BKR6ES-11	5553		LPG 1
Impreza Estate/Wagon Plus 2.0	G11GG	2.0	92	4	10.00-12.07	EJ201		1,1	BKR6ES-11	5553		LPG 1
Impreza		2.0	92	4	12.00-	EJ20		1,1	BKR6E-11	2756	14	LPG 1
Impreza 2.0 RS		2.0	92	4	11.04-	EJ20		1,1	BKR6E-11	2756	14	LPG 1
Impreza 2.0R		2.0	110	4	09.07-	EK20		0,8	ILFR6B	6481		
Impreza 2.0	G12GE	2.0	110	4	09.07-02.10	EJ204		1,1	SILFR6A11	5468		
Impreza 2.0		2.0	110	4	01.08-02.10	EJ204		1,1	SILFR6A11	5468		
Impreza 2.0 BiFuel	G12GH	2.0	110	4	01.09-02.10	EJ204		1,1	SILFR6A11	5468		
Impreza 2.0		2.0	110	4	03.10-	EJ204		1,1	SILFR6C11	7505		
Impreza 2.0 BiFuel	G12GH	2.0	110	4	03.10-03.12	EJ204		1,1	SILFR6C11	7505		
Impreza 2.0	G12GE	2.0	110	4	03.10-03.12	EJ204		1,1	SILFR6C11	7505		
Impreza R		2.0	118	4	.06-	EJ20		0,8	ILFR6B	6481		
Impreza Turbo		2.0	155	4	05.94-07.96	EJ20		0,8	PFR6G	4793		PFR7G
Impreza Turbo		2.0	160	4	03.94- .00	EJ20		0,9	PFR6B	3500		LPG 1
Impreza WRX Turbo		2.0	160	4	10.00-12.05	EJ205		0,8	PFR6G	4793		PFR7G
Impreza WRX 2.0	G11GD	2.0	160	4	10.00-12.05	EJ205		0,8	PFR6G	4793		PFR7G
Impreza WRX Estate/Wagon Plus 2.0	G11GG	2.0	160	4	10.00-12.05	EJ205		0,8	PFR6G	4793		PFR7G
Impreza WRX Turbo		2.0	165	4	12.02-09.06	EJ205		0,8	PFR6G	4793		PFR7G
Impreza WRX 2.0	G11GD	2.0	165	4	12.02-03.07	EJ205		0,8	PFR6G	4793		PFR7G
Impreza WRX Estate/Wagon Plus 2.0	G11GG	2.0	165	4	12.02-09.06	EJ205		0,8	PFR6G	4793		PFR7G
Impreza WRX Turbo		2.0	169	4	.06-	EJ25		0,8	ILFR6B	6481		
Impreza WRX Sti		2.0	195	4	.03-	EJ20		0,8	PFR6G	4793		PFR7G
Impreza WRX 2.0 STi Prodrive Performance Pack	G11GD	2.0	224	4	04.01-10.02	EJ207		0,8	PFR6G	4793		PFR7G
Impreza 2.5	G11GD	2.5	112	4	12.02-09.05	EJ251		1,1	BKR6ES-11	5553		LPG 1
Impreza 2.5	G11GD	2.5	130	4	03.01-09.06	EJ251		1,1	BKR6ES-11	5553		LPG 1
Impreza WRX		2.5	169	4	09.05-	EJ25		0,8	ILFR6B	6481		
Impreza WRX 2.5	G22GR	2.5	169	4	09.07-08.13	EJ255		0,8	SILFR6A	7913		
Impreza WRX 2.5	G12GH, G22GV	2.5	169	4	01.08-08.13	EJ255		0,8	SILFR6A	7913		
Impreza WRX 2.5 S	G22GV	2.5	188	4	02.09-12.10	EJ257		0,8	SILFR6A	7913		
Impreza WRX Estate/Wagon Plus 2.5 GB270	G11GG	2.5	198	4	07.07-12.07	EJ255		0,8	ILFR6B	6481		
Impreza WRX Sti St1		2.5	206	4	09.05-	EJ25		0,8	ILFR6B	6481		
Impreza WRX Sti		2.5	206	4	.06-	EJ25		0,8	ILFR6B	6481		





l kW C
Y
I



Stock-N°

VLINE

LPG/CNG

SUBARU

IMPREZA

Impreza WRX 2.5 STi	G11GD	2.5	221	4	10.05-03.07	EJ257	0,8	ILFR6B	6481		
Impreza WRX Sti (GRF)		2.5	221	4	01.08-	EJ25	0,8	SILFR6A	7913		
Impreza WRX 2.5 STi	G22GR	2.5	221	4	06.10-08.13	EJ257	0,8	SILFR6A	7913		
Impreza WRX 2.5 330S	G12GH	2.5	242	4	05.09-12.10	EJ255	0,8	SILFR6A	7913		
Impreza WRX 2.5 STi	G22GV	2.5	294	4	04.10-08.13	EJ257	0,8	SILFR6A	7913		

JUSTY

Justy 1.0 (Daihatsu Engine)		1.0	52	3	.07-	1KR-FE	1,1	ILFR6T11	4904		
Justy 1000		1.0		4	.85- .03	EF10 Cat.	1,1	BPR6ES-11	4824	13	LPG 2
Justy 1200		1.2	55	4	.87- .03	EF12, EF12 Cat.	1,1	BPR6ES-11	4824	13	LPG 2
Justy 1300		1.3	50	4	10.95- .03	G13BA	0,8	BPR6ES	7822	2	LPG 2
Justy		1.3	63	4	- .03	G13BB	1,1	BKR6E-11	2756	14	LPG 1
Justy G3X		1.3	69	4	09.03-	M13A DOHC	1,1	BKR6E-11	2756	14	LPG 1
Justy G3X		1.5	73	4	09.03-	M15A DOHC	1,1	IFR6J11	7658		

L-1800

L-1800 MPFJ		1.8	72	4	.87-	EA82	1,1	BPR6ES-11	4824	13	LPG 2
-------------	--	-----	----	---	------	------	-----	------------------	-------------	-----------	--------------

LEGACY

Legacy 1.8 Sedan		1.8	76	4	.90- .91	EJ18/4	1,1	BKR6E-11	2756	14	LPG 1
Legacy 1.8 Station		1.8	76	4	.90- .91	EJ18/4	1,1	BKR6E-11	2756	14	LPG 1
Legacy 1.8 Super Station		1.8	76	4	.90- .91	EJ18/4	1,1	BKR6E-11	2756	14	LPG 1
Legacy 2.0 Sedan		2.0	84	4	.92- .95	EJ20/4	1,1	BKR6E-11	2756	14	LPG 1
Legacy 2.0 Super Station		2.0	84	4	.92- .95	EJ20	1,1	BKR6E-11	2756	14	LPG 1
Legacy 2.0		2.0	85	4	05.94-	EJ20	1,1	BKR6E-11	2756	14	LPG 1
Legacy 2.0		2.0	92	4	12.98- .03	EJ20	1,1	BKR6E-11	2756	14	LPG 1
Legacy 2.0 Turbo Sedan		2.0	147	4	.92- .93	EJ20	0,8	PFR6B	3500		LPG 1
Legacy 2.0 Turbo Sup.Stat.		2.0	147	4	.92- .93	EJ20	0,8	PFR6B	3500		LPG 1
Legacy 2.0 Turbo		2.0	147	4	.93- .96	EJ20	0,8	PFR6G	4793		PFR7G
Legacy		2.2	94	4	05.94- .02	EJ22	1,1	BKR6E-11	2756	14	LPG 1
Legacy 2.2 Station		2.2	96	4	.94- .02	EJ22	1,1	BKR6E-11	2756	14	LPG 1
Legacy 2.2 Sedan		2.2	100	4	.90- .93	EJ22	1,1	BKR6E-11	2756	14	LPG 1
Legacy 2.2 Super Station		2.2	100	4	.90- .94	EJ22/4	1,1	BKR6E-11	2756	14	LPG 1
Legacy Outback		2.5	110	4	.96- .02	EJ25	1,1	PFR6B-11	4014		PFR7B
Legacy 2.5 Outback		2.5	115	4	12.98- .03	EJ25	1,1	BKR6E-11	2756	14	LPG 1
Legacy H6-3.0		3.0	154	6	.01- .03		1,1	PLFR6A-11	7654		LPG 7
Legacy Outback H6-3.0		3.0	154	6	.01- .03		1,1	PLFR6A-11	7654		LPG 7
Legacy 3.0R spec.B Kombi		3.0	180	6	02.05-	EZ30	0,8	ILFR6B	6481		
Legacy 3.6		3.6	188	6	04.09-	EZ5 H6	1,1	SILFR6C11	7505		

LEGACY III

Legacy 2.0	B12BE	2.0	92	4	10.98-08.03	EJ201	1,1	BKR6ES-11	5553		LPG 1
Legacy Estate/Wagon 2.0	B12BH	2.0	92	4	10.98-08.03	EJ201	1,1	BKR6ES-11	5553		LPG 1
Legacy 2.5	B12BE	2.5	115	4	10.98-08.03	EJ251	1,1	BKR6ES-11	5553		LPG 1
Legacy Estate/Wagon 2.5	B12BH	2.5	115	4	10.98-08.03	EJ251	1,1	BKR6ES-11	5553		LPG 1

LEGACY IV

Legacy 2.0	B13BL	2.0	101	4	09.03-10.05	EJ20	1,1	BKR6E-11	2756	14	LPG 1
Legacy 2.0	B13BL	2.0	101	4	09.03-10.05	EJ202	1,1	BKR6ES-11	5553		LPG 1
Legacy Estate/Wagon 2.0	B13BP	2.0	101	4	09.03-10.05	EJ202	1,1	BKR6ES-11	5553		LPG 1





kw C
Y
I



Stock-N°

VLINE

LPG/CNG

SUBARU

LEGACY IV

Legacy 2.0	B13BL	2.0	110	4	06.03-04.09	EJ204	0,8	ILFR6B	6481		
Legacy 2.0	B13BL	2.0	110	4	06.03-12.09	EJ204	0,8	ILFR6B	6481		
Legacy Estate/Wagon 2.0	B13BP	2.0	110	4	09.07-12.09	EJ204	0,8	ILFR6B	6481		
Legacy IV 2.0	B13BL	2.0	121	4	06.05-04.09	EJ20X	0,8	ILFR6B	6481		
Legacy IV 2.5	B13BL	2.5	121	4	09.03-04.09	EJ25	1,1	PFR5B-11	2300		PFR6B
Legacy Estate/Wagon 2.5	B13BP	2.5	127	4	01.08-12.09	EJ252	1,1	PFR5B-11	2300		PFR6B
Legacy IV 3.0 R	B13BL	3.0	180	6	09.03-06.09	EZ30	0,8	ILFR6B	6481		

LEGACY V

Legacy V 2.0	B14BM	2.0	110	4	04.09-	EJ204	1,1	SILFR6C11	7505		
Legacy V 2.5	B14BM	2.5	123	4	09.09-	EJ253	1,1	SIFR6A11	0127		

LEVORG

Levorg 1.6	V10, VM4	1.6	125	4	03.15-	FB16E, FB16F	0,6	SILKAR8D6	95768		
------------	----------	-----	-----	---	--------	--------------	-----	-----------	-------	--	--

LIBERO

Libero 1200		1.2	38	4	.87- .00	EF12	1,1	BPR6ES-11	4824	13	LPG 2
-------------	--	-----	----	---	----------	------	-----	-----------	------	----	-------

MV PICKUP

MV Pickup		1.8		4	.80- .94		0,8	BPR6ES	7822	2	LPG 2
-----------	--	-----	--	---	----------	--	-----	--------	------	---	-------

OUTBACK

Outback 2.5	B12BH	2.5	115	4	01.00-08.03	EJ251	1,1	BKR6ES-11	5553		LPG 1
Outback 2.5 (BL, BP)		2.5	121	4	09.03-	EJ25	1,1	PFR5B-11	2300		PFR6B
Outback 2.5 (BM, BR)	B14BR	2.5	123	4	09.09-	EJ253	1,1	SIFR6A11	0127		
Outback 2.5	B13BP	2.5	127	4	09.08-09.09	EJ252	1,1	PFR5B-11	2300		PFR6B
Outback 3.0 R (BL, BP)		3.0	180	6	11.03-	EZ30	0,8	ILFR6B	6481		
Outback 3.6 R (BM, BR)		3.6	191	6	09.09-	EZ36D	1,1	SILFR6C11	7505		

PLEO

Pleo (RA1,RA2)		0.66		4	10.01-01.04	EN07	0,8	KR8BI	4347		
----------------	--	------	--	---	-------------	------	-----	-------	------	--	--

R1

R1 (RJ1,RJ2)		0.66		4	.06-	EN07	0,8	KR8BI	4347		
--------------	--	------	--	---	------	------	-----	-------	------	--	--

R2

R2 (RC1,RC2)		0.66		4	12.03-	EN07	0,8	KR8BI	4347		
--------------	--	------	--	---	--------	------	-----	-------	------	--	--

SVX

SVX		3.3	162	6	.92-12.97	EG33	1,1	PFR6G-11	5555		PFR7G
-----	--	-----	-----	---	-----------	------	-----	----------	------	--	-------

TREZIA

Trezia 1.3	NSP120L	1.3	73	4	01.11-	1NR-FE	1,1	ILKAR7B11	4912		
------------	---------	-----	----	---	--------	--------	-----	-----------	------	--	--

TRIBECA

Tribeca B9		3.0	184	6	.06-	EZ30	0,8	ILFR6B	6481		
Tribeca B9		3.6	190	6	09.07-	EZ36D	0,8	SILFR6A	7913		
Tribeca 3.6	W10WX	3.6	190	6	09.07-03.14	EZ36D	1,1	SILFR6C11	7505		

WRX

WRX 2.0	VAGK	2.0	197	4	06.14-	FA20F	0,6	ILKAR8H6	96024		
WRX 2.0	V10, VAG	2.0	197	4	06.14-	FA20F	0,6	ILKAR8H6	96024		
WRX 2.5 STi	V10, VAF	2.5	221	4	06.14-	EJ257	0,8	SILFR6A	7913		

XV

XV 1.6i	G33	1.6	84	4	03.12-	FB16A, FB16B	1,1	SILZKAR7B11	93482		
SUBARU XV 1.6	GT3	1.6	84	4	08.17-	FB16A	1,1	DILZKAR7B11	90935		
XV 2.0i	G33	2.0	110	4	03.12-	FB20A, FB20B	1,1	SILZKAR7B11	93482		





l kW C
Y
I



Stock-N°

VLINE

LPG/CNG

SUZUKI

ALTO

Alto (HA24V)	0,6		3	01.05-	K6A	0,8	KR7AI	7789		
Alto (SB308)	0,8	29	3	.86- .92	F8B	0,9	BPR5ES	7422	6	LPG 2
Alto (SH410)	1,0	39	4	.94- .00	G10B	0,8	BPR5EY	2828	9	LPG 2
Alto (AMF310)	1,0	50	3	04.09-	K10B	1,1	IKR6G11	7980		
Alto (SH410)	1,0	53	4	.94-12.00	G10B	0,8	BPR5EY	2828	9	LPG 2
Alto	1,0		4	01.01-	G10B	0,9	BKR6E	6962	28	LPG 1
Alto (FF)	1,1	46	4	06.02-	K10A, F10D DOHC 16V	0,8	DCPR7E	3932		
Alto Lapin HE21S	1,6		4	01.02-	K6A...	0,8	DCPR7E	3932		

BALENO

Baleno 1.0	A1K310	1,0	82	3	02.16-	K10CT	0,8	ILZKR7D8	96412		
SUZUKI Baleno 1.2 Hybrid / VVT Dualjet	A1K412	1,2	66	4	02.16-	K12C	1,1	ILZKR6F11	97345		
Baleno 1.3 (Chassis No 00200001→)	SY-413GA11H	1,3	52	4	11.95-10.98	G13BA	1,1	BKR6E-11	2756	14	LPG 1
Baleno 1.3 (Chassis No 00200001→)	SY-413GA11H	1,3	63	4	03.95-05.02	G13BB	1,1	BKR6E-11	2756	14	LPG 1
Baleno (SY413)		1,3	63	4	04.95-	G13BB	0,9	BKR6E	6962	28	LPG 1
Baleno Estate/Wagon 1.3 (Chassis No 00200001→)	SY413GC11W	1,3	63	4	06.97-05.02	G13BB	1,1	BKR6E-11	2756	14	LPG 1
Baleno (SY416)		1,6	72	4	04.95-	G16B	0,9	BKR6E	6962	28	LPG 1
Baleno 1.6 (Chassis No 00300001→)	SY-416GA31H	1,6	72	4	04.95-05.02	G16B	1,1	BKR6E-11	2756	14	LPG 1
Baleno 1.6 (Chassis No 00300001→)	SY416GB31H	1,6	72	4	07.95-05.02	G16B	1,1	BKR6E-11	2756	14	LPG 1
Baleno Estate/Wagon 1.6 (Chassis No 00300001→)	SY416GD31W	1,6	72	4	08.96-05.02	G16B	1,1	BKR6E-11	2756	14	LPG 1
Baleno Estate/Wagon 1.6 (Chassis No 00300001→)	SY416GC31W	1,6	73	4	08.96-05.02	G16B	1,1	BKR6E-11	2756	14	LPG 1
Baleno		1,6		4	.95-	G16A (16V)	0,9	BKR6E	6962	28	LPG 1
Baleno (SY418)		1,8	89	4	03.96-12.00	J18A	1,1	BKR6E-11	2756	14	LPG 1
Baleno 1.8	SY-418GA41H, SY418GC41S	1,8	89	4	03.96-05.02	J18A	1,1	IFR6J11	7658		
Baleno Estate/Wagon 1.8	SY418GC41W	1,8	89	4	08.96-05.02	J18A	1,1	IFR6J11	7658		
Baleno (SY418)		1,8	89	4	11.00-	16V	1,1	IFR6J11	7658		

CAPPUCCINO

Cappuccino 660 12V Turbo		0,66	47	3	09.91-	F6A DOHC Cat.	0,8	DCPR7EIX	6046		LPG 8
Cappuccino 660 12V Turbo		0,66	47	3	05.95-	K6A DOHC Cat.	0,8	DCPR7EIX	6046		LPG 8

CARRY

Carry (DA51T/B,DB51T)		0,66		3	03.90-09.91	F6A 4Valve	0,8	DCPR7E	3932		
Carry (DE51V,DF51V)		0,66		3	09.91-01.99	F6A 2Valve Turbo	0,9	BPR5E	7281	6	LPG 2
Carry (DC51T/B,DD51T)		0,66		3	09.91-01.99	F6A 4Valve	0,8	DCPR7E	3932		
Carry (DE51V,DF51V)		0,66		3	09.91-01.99	F6A 4Valve	0,8	DCPR7E	3932		
Carry (DC51T,DD51T)		0,66		3	04.97-01.99	F6A 2Valve Turbo	0,7	PGR5A	3987		
Carry (DA52T,DB52T)		0,66		3	01.99-05.00	F6A 2Valve Turbo	0,9	BPR5E	7281	6	LPG 2
Carry (DA52T,DB52T)		0,66		3	01.99-09.01	F6A 4Valve	0,8	DCPR7E	3932		
Carry (DA62T)		0,66		3	09.01-05.02	K6A 4Valve DOHC	0,8	DCPR7E	3932		
Carry (DA63T)		0,66		3	05.02-	K6A 4Valve DOHC	0,8	DCPR7E	3932		
Carry (DA63T)		0,66		3	05.02-	K6A 4Valve DOHC	0,8	KR7AI	7789		
Carry		1,3		4	06.99-	G13BB	0,9	BKR6E	6962	28	LPG 1

CARRY SUPER

Carry Super (SK410)		1,0	31	4	.92- .99	F10A Cat.	0,9	BPR5ES	7422	6	LPG 2
---------------------	--	-----	----	---	----------	-----------	-----	--------	------	---	-------





l kW C
Y
I



Stock-N°

VLINE

LPG/CNG

SUZUKI

CARRY SUPER

Carry Super (SK410)	1.0	33	4	.87- .99	F10A u.Cat.	0,9	BPR5ES	7422	6	LPG 2
---------------------	-----	----	---	----------	-------------	-----	--------	------	---	-------

CARRY VAN

Carry Van	1.3		4	.99-	G13BB	0,9	BKR6E	6962	28	LPG 1
-----------	-----	--	---	------	-------	-----	-------	------	----	-------

ESCUDO

Escudo	1.6	71	4	08.90-11.97	G16A	0,9	BKR6E	6962	28	LPG 1
Escudo	1.6	71	4	12.97-04.00	G16A	1,1	BKR6E-11	2756	14	LPG 1
Escudo	1.6	71	4	05.00-	G16A	1,1	IFR6E11	6741		
Escudo	2.0		4	12.94-10.96	H20A	0,9	BKR6E	6962	28	LPG 1
Escudo	2.0		4	10.96-11.97	J20A	0,9	BKR6E	6962	28	LPG 1
Escudo	2.0		4	11.97-04.00	J20A	1,1	BKR6E-11	2756	14	LPG 1
Escudo	2.0		4	04.00-04.05	J20A	1,1	IFR5J11	7418		IFR6J11
Escudo	2.0		6	04.00-	H25A	1,1	IFR5J11	7418		IFR6J11
Escudo (TD54W)	2.0		4	05.05-	J20A	1,1	IFR6J11	7658		
Escudo	2.5		6	10.96-11.97	H25A	0,9	BKR6E	6962	28	LPG 1
Escudo	2.5		6	03.98-04.00	H25A	1,1	BKR6E-11	2756	14	LPG 1

GRAND ESCUDO

Grand Escudo 2.0	JB420W2	2.0	103	4	10.05-12.11	J20A	1,1	IFR5J11	7418		IFR6J11
Grand Escudo 2.7 VVTi	JA627W4	2.7	135	6	04.03-09.05	H27A	1,1	BKR6E-11	2756	14	LPG 1

GRAND VITARA

Grand Vitara		1.6	69	4	03.98-	G16A, G16B	1,1	BKR6E-11	2756	14	LPG 1
Grand Vitara 1.6	SQ416Q	1.6	69	4	08.98-11.04	G16B	1,1	BKR6E-11	2756	14	LPG 1
Grand Vitara 1.6	SQ416Q	1.6	69	4	08.98-11.04	G16B	1,1	IFR6J11	7658		
Grand Vitara 1.6	SQ416V3, SQ416X2	1.6	69	4	02.01-11.04	G16B	1,1	IFR6E11	6741		
Grand Vitara (only D)		1.6	69	4	.01-	G16A, G16B	1,1	IFR6J11	7658		
Grand Vitara 1.6	SQ416V, SQ416V2, SQ416X3	1.6	71	4	08.98-11.04	G16B	1,1	BKR6E-11	2756	14	LPG 1
Grand Vitara 1.6	SQ416V, SQ416V2, SQ416X3	1.6	71	4	08.98-11.04	G16B	1,1	IFR6E11	6741		
Grand Vitara 1.6	SQ416V, SQ416V2, SQ416X3	1.6	71	4	08.98-11.04	G16B	1,1	IFR6J11	7658		
Grand Vitara (JB416)		1.6	78	4	04.05-	M16A VVT	1,1	IFR6J11	7658		
Grand Vitara		2.0	94	4	01.98-09.00	J20A	1,1	IFR6J11	7658		
Grand Vitara 2.0 VVT	SQ420Q	2.0	94	4	03.98-07.03	J20A	1,1	BKR6E-11	2756	14	LPG 1
Grand Vitara 2.0 VVT	SQ420Q	2.0	94	4	03.98-07.03	J20A	1,1	IFR5J11	7418		IFR6J11
Grand Vitara 2.0 VVT	SQ420W3	2.0	94	4	03.98-11.04	J20A	1,1	IFR5J11	7418		IFR6J11
Grand Vitara 2.0 VVT	SQ420V2, SQ420X3	2.0	94	4	01.01-11.04	J20A	1,1	IFR5J11	7418		IFR6J11
Grand Vitara 2.0 VVT	SQ420V, SQ420X2	2.0	97	4	08.98-11.02	J20A	1,1	BKR6E-11	2756	14	LPG 1
Grand Vitara 2.0 VVT	SQ420V, SQ420X2	2.0	97	4	08.98-11.02	J20A	1,1	IFR5J11	7418		IFR6J11
Grand Vitara 2.0 VVT	SQ420W, SQ420W2, SQ420W3	2.0	103	4	04.98-09.05	J20A	1,1	BKR6E-11	2756	14	LPG 1
Grand Vitara 2.0 VVT	SQ420W, SQ420W2, SQ420W3	2.0	103	4	04.98-09.05	J20A	1,1	IFR5J11	7418		IFR6J11
Grand Vitara (JB420)		2.0	103	4	09.05-	M20A	1,1	IFR5E11	7994		IFR6E11
Grand Vitara (JB420)		2.0	103	4	09.05-	J20A	1,1	IFR5J11	7418		IFR6J11





e kW C
Y
I



Stock-N°

VLINE

LPG/CNG

SUZUKI

GRAND VITARA

Grand Vitara		2.0		4	10.00-	J20	1,1	IFR5J11	7418		IFR6J11
Grand Vitara 2.4 (JB424)		2.4	122	4	06.08-	J24B	1,1	SILFR6A11	5468		
Grand Vitara 2.4 (JB424)		2.4	124	4	06.08-	J24B	1,1	SILFR6A11	5468		
Grand Vitara V6 (SV620)		2.5	106	6	04.98-09.00	H25	1,1	BKR6E-11	2756	14	LPG 1
Grand Vitara 2.5	SQ625W2, SQ625W3	2.5	116	6	04.01-12.05	H25A	1,1	BKR6E-11	2756	14	LPG 1
Grand Vitara V6 (SV620)		2.5	125	6	01.98-	H25A	1,1	BKR6E-11	2756	14	LPG 1
Grand Vitara		2.5		6	10.00-	H25	1,1	IFR5J11	7418		IFR6J11
Grand Vitara XL-7 2.7 VVTi	JA627W	2.7	127	6	07.01-08.02	H27A	1,1	BKR6E-11	2756	14	LPG 1
Grand Vitara V6		2.7	127	6	09.01-	H27A	1,1	IFR5J11	7418		IFR6J11
Grand Vitara XL7 (UBD) JB627W		2.7	135	6	04.03-08.08	H27A	1,1	IFR6J11	7658		
Grand Vitara XL-7 2.7 VVTi	JA627W	2.7	135	6	09.03-08.06	H27A	1,1	BKR6E-11	2756	14	LPG 1

GRAND VITARA II

Grand Vitara 1.6 VVT	JB416X, JB416X2, JB416X4, JB416X5, JB416X6, JB416X7	1.6	73	4	09.05-02.15	M16A	1,1	IFR6J11	7658		
----------------------	--	-----	----	---	-------------	------	-----	---------	------	--	--

IGNIS

Ignis 1.3	RG413	1.3	61	4	10.00-09.03	M13A	1,1	IFR6J11	7658		
-----------	-------	-----	----	---	-------------	------	-----	---------	------	--	--

IGNIS II

Ignis II 1.3	RM413	1.3	69	4	10.03-	M13A mit V V T	1,1	IFR6J11	7658		
Ignis 1.3 VVTi	RM413HX51	1.3	69	4	10.03-12.10	M13A	1,1	IFR6J11	7658		
Ignis II 1.5	RM415	1.5	73	4	08.03-	M15A mit V V T	1,1	IFR6J11	7658		
Ignis II 1.5i Sport	RG415	1.5	80	4	08.03-	M15A	1,1	IFR6J11	7658		

IGNIS III

SUZUKI Ignis III 1.2 VVT Dualjet / VVT Dualjet Hybrid	ATK412	1.2	66	4	09.16-	K12C	1,1	ILZKR6F11	97345		
---	--------	-----	----	---	--------	------	-----	-----------	-------	--	--

JIMNY

Jimny 1.3	SN413	1.3	59	4	09.98-04.01	G13BB	0,9	BKR6E	6962	28	LPG 1
Jimny Cabrio		1.3	59	4	10.98-	G13BB	0,9	BKR6E	6962	28	LPG 1
Jimny		1.3	60	4	05.01-07.04	M13A	1,1	IFR6J11	7658		
Jimny 1.3 VVT	SN413	1.3	60	4	05.01-07.04	M13A	1,1	BKR6E-11	2756	14	LPG 1
Jimny 1.3 VVT	SN413	1.3	60	4	05.01-07.04	M13A	1,1	IFR5J11	7418		IFR6J11
Jimny 1.3 VVT	SN413	1.3	62	4	05.14-	M13A	1,1	BKR6E-11	2756	14	LPG 1
Jimny 1.3 VVT	SN413	1.3	62	4	05.14-	M13A	1,1	IFR6J11	7658		
Jimny 1.3 VVT	SN413	1.3	63	4	10.00-	M13A	1,1	BKR6E-11	2756	14	LPG 1
Jimny 1.3 VVT	SN413	1.3	63	4	10.00-	M13A	1,1	IFR5J11	7418		IFR6J11
Jimny 1.3 VVT	SN413	1.3	63	4	08.04-	M13A	1,1	IFR5J11	7418		IFR6J11
Jimny 1.3 VVT	SN413	1.3	63	4	08.04-	M13A	1,1	IFR6J11	7658		
Jimny		1.3	63	4	08.05-	M13A	1,1	IFR6J11	7658		
Jimny 1.3 VVT	SN413	1.3	63	4	03.13-	M13A	1,1	BKR6E-11	2756	14	LPG 1
Jimny 1.3 VVT	SN413	1.3	63	4	03.13-	M13A	1,1	IFR6J11	7658		

KIZASHI

Kizashi 2.4	FR	2.4	131	4	10.10-	J24B	1,1	SILFR6A11	5468		
-------------	----	-----	-----	---	--------	------	-----	-----------	------	--	--

LIANA

Liana		1.3	66	4	03.01-01.04	M13A	1,1	BKR6E-11	2756	14	LPG 1
-------	--	-----	----	---	-------------	------	-----	----------	------	----	-------





l kW C
Y I



Stock-N°

VLINE

LPG/CNG

SUZUKI

LIANA

Liana 1.3	RH4132, RH4133, RH4134, RH413F	1.3	66	4	03.01-08.06	M13A	1,1	IFR6J11	7658		
Liana 1.3	RH4132, RH4133, RH4134	1.3	66	4	10.01-08.06	M13A	1,1	IFR6J11	7658		
Liana		1.3	66	4	02.04-	M13A	1,1	IFR6J11	7658		
Liana 1.6 VVT	RH4162, RH4163, RH4164, RH4165, RH416F	1.6	76	4	03.01-08.04	M16A	1,1	IFR6E11	6741		
Liana 1.6 VVT	RH4162, RH4163, RH4164, RH4165, RH416F	1.6	76	4	03.01-08.04	M16A	1,1	IFR6J11	7658		
Liana 1.6 VVT	RH4162, RH4163, RH4164, RH4165, RH416F	1.6	76	4	07.01-12.07	M16A	1,1	IFR6E11	6741		
Liana 1.6 VVT	RH4162, RH4163, RH4164, RH4165, RH416F	1.6	76	4	07.01-12.07	M16A	1,1	IFR6J11	7658		
Liana 1.6 VVT	RH4162, RH4163, RH4164	1.6	76	4	10.01-03.04	M16A	1,1	IFR6J11	7658		
Liana		1.6	78	4	03.01-01.04		1,1	BKR6E-11	2756	14	LPG 1
Liana 1.6 VVT	RH4162, RH4163, RH4164, RH4165, RH416F	1.6	78	4	09.02-08.07	M16A	1,1	IFR6E11	6741		
Liana		1.6	78	4	02.04-	M16A	1,1	IFR6J11	7658		

SAMURAI

Samurai		1.0	33	4	.90-	F10A	0,9	BPR5ES	7422	6	LPG 2
Samurai (SJ413)		1.3	51	4	.90-	G13BA Cat.	0,9	BPR5ES	7422	6	LPG 2
Samurai		1.3	51	4	.92-	G13BA	0,9	BPR5ES	7422	6	LPG 2
Samurai Pick-up		1.3	51	4	10.99-10.00	G13BA	0,9	BPR5ES	7422	6	LPG 2

SK 410

SK 410 Super Carry		1.0	31	4	.85-	F10A	0,9	BPR5ES	7422	6	LPG 2
--------------------	--	-----	----	---	------	------	-----	--------	------	---	-------

SPLASH

Splash 1.0 (A5B310)		1.0	48	3	01.08-07.11	K10B	1,1	IKR6G11	7980		
Splash 1.0 VVT	A5B310	1.0	50	3	06.11-12.14	K10B	1,1	IKR6G11	7980		
Splash 1.2 (A5B412)		1.2	63	4	01.08-	K12B	1,1	IKR6G11	7980		
Splash 1.2 LPG	A5B412	1.2	63	4	04.08-12.14	K12B	1,1	IKR6G11	7980		
Splash 1.2 VVT	A5B412	1.2	66	4	06.11-12.14	K12B	1,1	IKR6G11	7980		
Splash 1.2 VVT (A5B412)		1.2	69	4	09.10-	K12B	1,1	IKR6G11	7980		

SWIFT

Swift (ZC31S)		1.6		4	09.05-	M16A	1,1	IFR6J11	7658		
---------------	--	-----	--	---	--------	------	-----	---------	------	--	--

SWIFT II

Swift II 1.0	SF310	1.0	39	3	09.91-05.01	G10A	0,8	BPR6ES	7822	2	LPG 2
Swift II 1.0	SF310	1.0	40	3	03.89-12.91	G10A	0,8	BPR6ES	7822	2	LPG 2
Swift II 1.3	SF413	1.3	50	4	03.89-05.01	G13A	0,8	BPR6ES	7822	2	LPG 2





l kW C
Y I



Stock-N°

VLINE

LPG/CNG

SUZUKI

SWIFT II

Swift II 1.3 4WD	SF413	1.3	50	4	03.89-05.01	G13A	0,8	BPR6ES	7822	2	LPG 2
Swift II 1.3 Gti	SF413	1.3	74	4	03.89-05.01	G13B	0,8	BPR6ES	7822	2	LPG 2
Swift II 1.6	SF416	1.6	68	4	01.90-05.01	G16B	0,9	BKR6E	6962	28	LPG 1
Swift II 1.6	SF416	1.6	70	4	11.89-12.91	G16B	0,9	BKR6E	6962	28	LPG 1

SWIFT III

Swift III 1.3 4X4	RS413	1.3	66	4	01.06-	M13A	1,1	IFR6J11	7658		
Swift III 1.3	RS413	1.3	68	4	02.05-	M13A	1,1	IFR6J11	7658		
Swift III 1.5	RS415	1.5	75	4	02.05-	M15A	1,1	IFR6J11	7658		
Swift III 1.6 Sport	RS416	1.6	92	4	05.06-	M16A	1,1	IFR6J11	7658		

SWIFT IV

Swift IV 1.2	AZG41	1.2	66	4	10.10-	K12B	1,1	IKR6G11	7980		
Swift IV 1.2	AZG41	1.2	69	4	10.10-	K12B	1,1	IKR6G11	7980		
Swift 1.3 LPG	RS413	1.3	68	4	09.08-12.10	M13A	1,1	IFR6J11	7658		
Swift IV 1.6	AZG41	1.6	100	4	01.12-	M16A	1,1	SILFR6A11	5468		

SWIFT VI

Swift VI 1.0 VVT / VTT Hybrid	A2L310	1.0	82	3	04.17-	K10C	0,8	ILZKR7D8	96412		
SUZUKI Swift VI 1.2 VVT / VTT Hybrid	A2L412	1.2	66	4	04.17-	K12C	1,1	ILZKR6F11	97345		
Swift 1.4 VVT Sport	A2L414	1.4	103	4	09.17-	K14C	0,8	ILZKR7D8	96412		

SX306

SX 306 Cappuccino		0.65	47		.94-	F6A	0,8	DCPR7EIX	6046		LPG 8
-------------------	--	------	----	--	------	-----	-----	----------	------	--	-------

SX4

SX4 1.6 VVT	RW416	1.6	82	4	07.09-12.15	M16A	1,1	IFR6J11	7658		
SX4 1.6 VVT	RW416	1.6	82	4	07.09-12.15	M16A	1,1	SILFR6A11	5468		
SX4 1.6 VVT	RW416	1.6	82	4	11.10-12.15	M16A	1,1	IFR6J11	7658		

SX4 I

SX4 I 1.5	RW415	1.5	73	4	06.06-	M15A	1,1	IFR6J11	7658		
SX4 I 1.5 (YB11S / XC11S)		1.5	73	4	.08-	M15A	1,1	IFR6J11	7658		
SX4 I 1.5 VVT	RW415	1.5	82	4	07.09-	M15A VVT	1,1	IFR6J11	7658		
SX4 I 1.6 VVT	RW416	1.6	79	4	06.06-	M16A VVT	1,1	IFR6J11	7658		
SX4 I 1.6 VVT	RW416	1.6	82	4	07.09-	M16A VVT	1,1	IFR6J11	7658		
SX4 I 1.6 VVT	RW416	1.6	88	4	07.09-	M16A VVT	1,1	IFR6J11	7658		

SX4 II

SX4 S-Cross 1.0 VVT	AKK310	1.0	82	3	08.16-	K10C	0,8	ILZKR7D8	96412		
SX4 1.4 VVT	AKK414	1.4	103	4	08.16-	K14C	0,8	ILZKR7D8	96412		
SX4 S-Cross 1.4 VVT	AKK414	1.4	103	4	08.16-	K14C	0,8	ILZKR7D8	96412		
SX4 II 1.6 VVT S-Cross	AKK416	1.6	88	4	08.13-	M16A	1,1	SILFR6A11	5468		

VITARA

Vitara 1.0	APK310	1.0	82	3	10.18-	K10C	0,8	ILZKR7D8	96412		
Vitara 1.4 S	APK414	1.4	103	4	09.15-	K14C	0,8	ILZKR7D8	96412		
Vitara		1.6	59	4	.91- .98	G16B Cat.	0,8	BPR6ES	7822	2	LPG 2
Vitara (SE416) Typ 2		1.6	59	4	- .98	G16A SOHC	0,9	BPR5ES	7422	6	LPG 2
Vitara (SE416) Typ 1		1.6	60	4	.88- .98	G16A SOHC Cat.	0,9	BPR5ES	7422	6	LPG 2
Vitara		1.6	60	4	.91- .98	G16A	0,9	BPR5ES	7422	6	LPG 2
Vitara		1.6	70	4	09.93- .98	G16B	0,9	BKR6E	6962	28	LPG 1
Vitara Long		1.6	71	4	.91- .98	G16B SOHC Cat.	0,9	BKR6E	6962	28	LPG 1





l kW
C
Y
I



Stock-N°

VLINE

LPG/CNG

SUZUKI

VITARA

Vitara 16V	1.6	71	4	04.95- .98	G16A	0,9	BKR6E	6962	28	LPG 1
Vitara	1.6		4	10.00-	G16A	1,1	IFR6E11	6741		
Vitara (SV620)	2.0	100	6	06.95-	H20A	0,9	BKR6E	6962	28	LPG 1
Vitara V6 (SV620)	2.5	125	6	05.98-	H25A	1,1	BKR6E-11	2756	14	LPG 1

WAGON

Wagon R+ 12V	1.0	44	3	03.05-	Z10XEP	0,8	ZFR5F	5165	53	LPG6
Wagon R+ (SR410)	1.0	48	4	.97-	K10A	0,8	DCPR7E	3932		
Wagon R+	1.0	55	4	02.04-	G10	1,1	BPR6ES-11	4824	13	LPG 2
Wagon R+	1.2	51	4	.98-	K12A	0,8	DCPR7E	3932		
Wagon R+ 16V	1.2	59	4	03.05-	Z12XEP	0,8	ZFR5F	5165	53	LPG6
Wagon R GL	1.3	56	4	04.00-	G13BB	1,1	BKR6E-11	2756	14	LPG 1
Wagon R+	1.3	68	4	02.04-	M13A mit VVT	1,1	IFR6J11	7658		

WAGON R

Wagon R+ 1.0	RB310	1.0	39	3	07.01-12.06	G10A	1,1	BPR6ES-11	4824	13	LPG 2
Wagon R+ 1.3	RB413	1.3	56	4	04.99-08.03	G13BB	1,1	BKR6E-11	2756	14	LPG 1
Wagon R 1.3 VVTi	RB413	1.3	65	4	09.03-12.12	M13A	1,1	IFR6J11	7658		

X-90

X-90	1.6	71	4	10.95-	G16A	0,9	BKR6E	6962	28	LPG 1
X-90	1.6	71	4	03.96-	G16B, G16W	0,9	BKR6E	6962	28	LPG 1

TALBOT

SIMCA 1100 SPECIAL / BREAK

Simca 1100 Special / Break	1.1		4	01.72-		0,6	BP7ES	2412		BPR8EIX
----------------------------	-----	--	---	--------	--	-----	-------	------	--	---------

TATRA

613-3

613-3	3.5	123	6	01.84-03.94		0,7	BCP6ES	4930	17	LPG 3
-------	-----	-----	---	-------------	--	-----	--------	------	----	-------

613-4

613-4	3.5	124	8	.93-		0,9	BKR6E	6962	28	LPG 1
-------	-----	-----	---	------	--	-----	-------	------	----	-------

TAXI

AUSTIN FX4

AUSTIN FX4			4	.74-		0,8	BR5ES	4722		
------------	--	--	---	------	--	-----	-------	------	--	--

TOFAS

124 SERCE

124 Serce	1.3	48	4	09.83-		0,7	BP6ES	7811	4	LPG 2
-----------	-----	----	---	--------	--	-----	-------	------	---	-------

131 DOGAN

131 Dogan	1.6	55	4	03.81-		0,7	BP6ES	7811	4	LPG 2
131 Dogan S/SX/SLX	1.6	55	4	06.92-		0,8	BPR6ES	7822	2	LPG 2

131 KARTAL

131 Kartal L	1.6	55	4	03.81-06.92		0,7	BP6ES	7811	4	LPG 2
131 Kartal SL / SLX	1.6	55	4	06.92-		0,8	BPR6ES	7822	2	LPG 2

SAHIN

Sahin	1.6	55	4	02.82-		0,7	BP6ES	7811	4	LPG 2
-------	-----	----	---	--------	--	-----	-------	------	---	-------

TEMPRA

Tempra	1.6	63	4	11.90-		0,8	BPR6ES	7822	2	LPG 2
Tempra i.e.	2.0	88	4	07.92-		0,8	BPR6ES	7822	2	LPG 2





l kW C
I



Stock-Nº

VLINE

LPG/CNG

TOFAS / FIAT

BRAVA

Brava 1.4 12V	1.4		4	10.95-10.98	12V	0,9	BKR6EKC	2848	26	LPG 1
---------------	-----	--	---	-------------	-----	-----	---------	------	----	-------

BRAVO

Bravo 16V	1.2		4	11.98-09.01	16V	0,9	DCPR8E-N	5692		LPG 8
Bravo 1.4 12V	1.4		4	10.95-10.98	12V	0,9	BKR6EKC	2848	26	LPG 1

MAREA

Marea 1.4 12V	1.4		4	10.96-02.99	12V	0,9	BKR6EKC	2848	26	LPG 1
Marea 2.0 20V	2.0		4	10.96-02.99	20V	0,9	BKR6EKC	2848	26	LPG 1

PALIO

Palio 1.2 i.e.	1.2		4	10.01-	16V	0,9	DCPR8E-N	5692		LPG 8
Palio Weekend 1.2 i.e.	1.2		4	10.01-	16V	0,9	DCPR8E-N	5692		LPG 8
Palio 16V	1.3		4	03.00-	188A9.000	0,9	DCPR8E-N	5692		LPG 8
Palio Weekend 16V	1.3		4	03.00-	MPI16V	0,9	DCPR8E-N	5692		LPG 8
Palio Weekend 1.4 i.e.	1.4		4	09.98-06.01		0,8	BKR5EK	7956	23	LPG 1

SIENA

Sienna 16V	1.3		4	03.00-	MPI16V	0,9	DCPR8E-N	5692		LPG 8
Sienna 1.4 i.e.	1.4		4	05.98-06.01		0,8	BKR5EK	7956	23	LPG 1

STILO

Stilo 16V	1.2		4	10.01-	16V	0,9	DCPR8E-N	5692		LPG 8
Stilo 1.6 16V	1.6		4	10.01-	16V	0,9	BKR5EZ	7642	36	LPG 1
Stilo S.W. 1.6 16V	1.6		4	01.03-	16V	0,9	BKR5EZ	7642	36	LPG 1
Stilo 1.8 16V	1.8		4	10.01-	16V	0,9	BKR6EZ	4619	38	LPG 1
Stilo S.W. 1.8 16V	1.8		4	01.03-	16V	0,9	BKR6EZ	4619	38	LPG 1

TOYOTA

4 RUNNER

4 Runner	2.4	82	4	.89- .95	22R, 22R-E Cat	0,8	BPR5EY	2828	9	LPG 2
4 Runner	RZN185	2.7	112	6	.98-12.99	3RZ-FE	0,8	BKR5EYA	2087	LPG 1
4 Runner	VZN185	2.7	112	6	.98-12.99	3RZ-FE	0,8	BKR5EYA	2087	LPG 1
4 Runner	RZN180, RZN185, VZN180, VZN185	2.7		6	01.00-	3RZ-FE	0,8	BKR5EYA	2087	LPG 1
4 Runner (with TWC)	VZN130	3.0	105	6	.89- .96	3VZE	0,8	BKR5EYA	2087	LPG 1
4 Runner	RZN185	3.4	136	6	.98-12.99	5VZ-FE	1,1	BKR5EKB-11	3967	
4 Runner	VZN185	3.4	136	6	.98-12.99	5VZ-FE	1,1	BKR5EKB-11	3967	
4 Runner	RZN180, RZN185, VZN180, VZN185	3.4		6	01.00-	5VZ-FE	1,1	BKR5EKB-11	3967	
4 Runner	GRN210, GRN215	4.0		6	01.04-	1GR-FE	1,1	LFR6C-11	5788	48

AURIS I

Auris I 1.33 VVT-i (NRE150)	1.33	73	4	01.10-09.12	1NR-FE	1,1	ILKAR7B11	4912			
Auris I 1.33 VVT-i (NRE150)	1.33	74	4	11.08-01.10	1NR-FE	1,1	ILKAR7B11	4912			
Auris I 1.4 VVT-i (ZRE151)	1.4	71	4	10.06-09.12	4ZZ-FE	1,1	BKR5EYA-11	2526	39	LPG 1	
Auris I 1.6 VVT-i (ZRE151)	1.6	91	4	10.06-09.12	1ZR-FE	1,1	ILKAR7B11	4912			
Auris I 1.6 (ZRE151)	1.6	97	4	12.08-09.12	1ZR-FAE	1,1	ILKAR7B11	4912			
Auris I 1.8 Hybrid	ZWE150	1.8	73	4	09.10-09.12	2ZR-FXE	1,1	ILKAR7B11	4912		
Auris I 1.8 (ZZE150)(ZRE151,152)	1.8	100	4	10.06-09.12	2ZR-FE	1,1	ILKAR7B11	4912			





l kW C
Y
I



Stock-N°

VLINE

LPG/CNG

TOYOTA

AURIS I

Auris I 1.8 (ZRE152H)	1.8	108	4	02.09-09.12	2ZR-FAE	1,1	ILKAR7B11	4912		
-----------------------	-----	-----	---	-------------	---------	-----	-----------	------	--	--

AURIS II

Auris II 1.33 VVT-i (NRE180)	1.33	73	4	10.12-	1NR-FE	1,1	ILKAR7B11	4912		
Auris II 1.5	1.5	80	4	10.12-	1NZFE	1,1	ILKAR7B11	4912		
Auris II 1.6 (ZRE181/185)	1.6	97	4	10.12-	1ZR-FAE	1,1	ILKAR7B11	4912		
Auris II 1.8 Hybrid	ZWE186	1.8	73	4	10.12-12.18	2ZR-FXE	1,1	DF6H-11B	5989	
Auris II Touring Sports 1.8 Hybrid	ZWE186	1.8	73	4	07.13-12.18	2ZR-FXE	1,1	ILKAR7B11	4912	
Auris II 1.8	1.8	103	4	10.12-	2ZR-FAE	1,1	ILKAR7B11	4912		
Auris II 1.8	1.8	106	4	10.12-	2ZR-FAE	1,1	ILKAR7B11	4912		

AVALON

Avalon (MCX20)	3.0		6	01.01-12.01	1MZFE	1,1	BKR6EKB-11	3583		
Avalon (MCX20)	3.0		6	01.02-	1MZFE	1,1	BKR6EKP-11	3452		

AVENSIS

Avensis (AT220,221,ST220)	1.6	81	4	04.98-	4A-FE	1,1	BKR6EYA-11	4073		LPG 1	
Avensis 1.6 VVTi	ZZT220	1.6	81	4	07.00-02.03	3ZZ-FE	1,1	BKR5EYA-11	2526	39	LPG 1
Avensis Estate/Wagon 1.6 VVTi	ZZT220	1.6	81	4	07.00-02.03	3ZZ-FE	1,1	BKR5EYA-11	2526	39	LPG 1
Avensis 1.6 VVTi	ZZT250	1.6	81	4	03.03-10.08	3ZZ-FE	1,1	BKR5EYA-11	2526	39	LPG 1
Avensis (AZT220)	1.6		4	01.02-	3ZZ-FE	1,1	BKR5EYA-11	2526	39	LPG 1	
Avensis (ST220)	1.6		4	01.02-	3ZZ-FE	1,1	BKR5EYA-11	2526	39	LPG 1	
Avensis (ZZT220, 221)	1.6		4	01.02-	3ZZ-FE	1,1	BKR5EYA-11	2526	39	LPG 1	
Avensis (ZZT250,251)(AZT250)	1.6		4	09.03-	3ZZ-FE	1,1	BKR5EYA-11	2526	39	LPG 1	
Avensis (AT220,221,ST220)	1.8	81	4	01.98-	7A-FE	1,3	BKR6EP-13	2550			
Avensis (ST220)	1.8	95	4	01.02-	1ZZ-FE	1,1	BKR5EYA-11	2526	39	LPG 1	
Avensis (ZZT220, 221)	1.8	95	4	01.02-	1ZZ-FE	1,1	BKR5EYA-11	2526	39	LPG 1	
Avensis (AZT220)	1.8		4	01.02-	1ZZ-FE	1,1	BKR5EYA-11	2526	39	LPG 1	
Avensis (ZZT250,251)(AZT250)	1.8		4	09.03-	1ZZ-FE	1,1	BKR5EYA-11	2526	39	LPG 1	
Avensis 2.0	ST220	2.0	94	4	10.97-06.00	3S-FE	1,1	BKR6EKB-11	3583		
Avensis Estate/Wagon 2.0	ST220	2.0	94	4	10.97-06.00	3S-FE	1,1	BKR6EKB-11	3583		
Avensis (AT220,221,ST220)	2.0	94	4	01.98-	3S-FE	1,1	BKR6EKP-11	3452			
Avensis (AZT250 / W)	2.0	108	4	03.03-10.08	1AZFSE	1,1	HB6BIX-11P	5705			
Avensis (AZT220)	2.0	110	4	07.00-02.03	1AZFSE	1,1	HB6BIX-11P	5705			
Avensis Estate/Wagon 2.0 VVTi	AZT250	2.0	114	4	03.03-10.08	1AZFE, 1AZFSE	1,1	IFR6T11	4589		
Avensis (AZT220)	2.0		4	01.02-	3S-FE	1,1	BKR6EKB-11	3583			
Avensis (ST220)	2.0		4	01.02-	3S-FE	1,1	BKR6EKB-11	3583			
Avensis (ZZT220, 221)	2.0		4	01.02-	3S-FE	1,1	BKR6EKB-11	3583			
Avensis (1AZ-FE)	2.0		4	01.03-	1AZFE without cat	1,1	BKR6EYA-11	4073		LPG 1	
Avensis (1AZ-FE)	2.0		4	01.03-	1AZFE with 3way cat	1,1	IFR6T11	4589			
Avensis (AZT251/ W)	2.4	120	4	10.03-10.08	2AZFSE	1,1	HB6BIX-11P	5705			

AVENSIS 2

Avensis 2 (ZZT250;251)(AZT250)	1.6	81	4	03.03- .09	3ZZ-FE	1,1	BKR5EYA-11	2526	39	LPG 1
Avensis 2 (ZZT250;251)(AZT250)	1.8	95	4	03.03- .09	1ZZ-FE	1,1	BKR5EYA-11	2526	39	LPG 1
Avensis 2 (ATZ250)	2.0	110	4	01.03- .09	1AZFE V V T-i	1,1	IFR6T11	4589		

AVENSIS 3

Avensis 3 (ZRT270)	1.6	81	4	04.08-	1ZR-FAE	1,1	ILKAR7B11	4912		
Avensis 3 (ZRT270)	1.6	97	4	11.08-	1ZR-FAE	1,1	ILKAR7B11	4912		





l kW C
Y I



Stock-N°

VLINE

LPG/CNG

TOYOTA

AVENSIS 3

Avensis 3 (ZRT271)	1.8	108	4	11.08-	2ZR-FAE	1,1	ILKAR7B11	4912		
Avensis 3 (ZRT272)	2.0	112	4	11.08-	3ZR-FAE	1,1	ILKAR7B11	4912		

AVENSIS VERSO

Avensis Verso (ACM20)	2.0	110	4	05.01-	1AZFE	1,1	IFR6T11	4589		
Avensis Verso (ACM20)	2.4		4	01.04-	2AZFE	1,1	BKR6EYA-11	4073		LPG 1

AYGO

Aygo	1.0	50	3	05.05-	1KR-FE	1,1	LFR6C-11	5788	48	
Aygo 1.0 LPG	KGB10	1.0	50	3	07.05-05.14	1KR-FE	1,1	ILFR5T11	96779	ILFR6T11
Aygo 1.0 VVTi	KGB10	1.0	50	3	07.05-05.14	1KR-FE	1,1	ILFR5T11	96779	ILFR6T11
Aygo 1.0 VVTi	KGB40	1.0	51	3	05.14-04.18	1KR-FE	1,1	DF6H-11B	5989	
Aygo 1.0 VVTi	KGB40	1.0	53	3	03.18-04.18	1KR-FE	1,1	DF6H-11B	5989	

CAMRY

Camry (SV20,21,25,VZV21)	2.0	89	4	.86-	3S-FE Cat.	1,1	BCPR6EY-11	3720		LPG 3
Camry (SV20,21,25,VZV21)	2.0	94	4	.87-	3S-FE	1,1	BCPR6EY-11	3720		LPG 3
Camry (ACV30,31)	2.0		4	08.01-	1AZFE	1,1	IFR6T11	4589		
Camry (MCV30)	2.0		4	08.01-	1AZFE	1,1	IFR6T11	4589		
Camry 2.2	SXV20	2.2	93	4	08.97-09.02	5S-FE	1,1	BKR6EKP-11	3452	
Camry (SXV10,VCV10)	2.2	100	4	.92-	5S-FE	1,1	BKR6EYA-11	4073		LPG 1
Camry MCV20	2.2	100	4	08.96-12.99	5S-FE without 3way cat	1,1	BKR6EKB-11	3583		
Camry SXV20	2.2	100	4	08.96-12.99	5S-FE without 3way cat	1,1	BKR6EKB-11	3583		
Camry MCV20	2.2	100	4	08.96-12.99	5S-FE with 3way cat	1,1	BKR6EKP-11	3452		
Camry SXV20	2.2	100	4	08.96-12.99	5S-FE with 3way cat	1,1	BKR6EKP-11	3452		
Camry (MCV20)	2.2		4	.98-12.99	5S-FE	1,1	BKR6EKP-11	3452		
Camry (SVX20)	2.2		4	.98-12.99	5S-FE	1,1	BKR6EKP-11	3452		
Camry (SVX20, MCV20)	2.2		4	01.00-	5S-FE	1,1	BKR6EKB-11	3583		
Camry (ACV30,31)	2.4	112	4	08.01-	2AZFE	1,1	IFR6T11	4589		
Camry (MCV30)	2.4	112	4	08.01-	2AZFE	1,1	IFR6T11	4589		
Camry (ACV 40)	2.4	116	4	01.06-	2AZFE	1,1	IFR6T11	4589		
Camry 2.4 VVTi	ACV40	2.4	123	4	01.06-09.11	2AZFE	1,1	IFR6T11	4589	
Camry 2.4 VVTi	ACV40	2.4	127	4	10.06-09.11	2AZFE	1,1	IFR6T11	4589	
Camry (SV21,25,VZV21)	2.5	118	6	.88- .92	2VZ-FE Cat.	1,1	BCPR6EP-11	3350		LPG 3
Camry 2.5 VVTi	ASV50	2.5	131	4	10.11-	2AR-FE	1,1	ILFR5T11	96779	ILFR6T11
Camry 2.5 VVTi	ASV50	2.5	133	4	09.11-	2AR-FE	1,1	ILFR5T11	96779	ILFR6T11
Camry 2.5 VVTi	ASV70	2.5	133	4	08.17-	2AR-FE	1,1	ILFR5T11	96779	ILFR6T11
Camry 3.0	MCV20	3.0	135	6	08.96-11.01	1MZFE	1,1	BKR6EKB-11	3583	
Camry (SVX20, MCV20)	3.0	137	6	01.00-	1MZFE V6	1,1	BKR6EKP-11	3452		
Camry (SXV10,VCV10)	3.0	138	6	.92-	3VZ-FE	1,1	BCPR6EP-11	3350		LPG 3
Camry MCV20	3.0	138	6	08.96-12.99	1MZFE without 3way cat	1,1	BKR6EKB-11	3583		
Camry SXV20	3.0	138	6	08.96-12.99	1MZFE without 3way cat	1,1	BKR6EKB-11	3583		
Camry MCV20	3.0	138	6	08.96-12.99	1MZFE with 3way cat	1,1	BKR6EKP-11	3452		
Camry SXV20	3.0	138	6	08.96-12.99	1MZFE with 3way cat	1,1	BKR6EKP-11	3452		
Camry 3.0	MCV20	3.0	140	6	08.96-11.01	1MZFE	1,1	BKR6EKB-11	3583	
Camry (ACV30,31)	3.0		6	08.01-	1MZFE	1,1	IFR6T11	4589		
Camry (MCV30)	3.0		6	08.01-	1MZFE	1,1	IFR6T11	4589		
Camry 3.5 VVTi	GSV50	3.5	183	6	12.12-	2GR-FE	1,1	DILFR6D11	6176	





kw CYI



Stock-No

VLINE

LPG/CNG

TOYOTA

CAMRY

Camry 3.5 VVTi	GSV40	3.5	200	6	01.06-12.11	2GR-FE	1,1	DILFR6D11	6176		
Camry 3.5 VVTi	GSV40	3.5	204	6	09.06-12.14	2GR-FE	1,1	DILFR6D11	6176		
Camry 3.5 VVTi	GSV50	3.5	204	6	09.11-12.17	2GR-FE	1,1	DILFR6D11	6176		

CARINA E

Carina E (AT190,191,ST191)		1.6	77	4	.93- .97	4A-FE Lean Burn engine	1,3	BKR6EP-13	2550		
Carina E (AT190,191,ST191)		1.6		4	.93- .97	4A-FE Standard engine	0,8	BKR6EYA	2249		LPG 1
Carina E (AT190,191,ST191)		1.8	79	4	.95-	7A-FE	1,3	BKR6EP-13	2550		
Carina E (AT190,191,ST191)		2.0	98	4	.93- .97	3S-FE Cat.	1,1	BKR6EYA-11	4073		LPG 1
Carina E (AT190,191,ST191)		2.0	116	4	.93-	3S-GE Cat.	0,8	BKR6EP-8	2215		LPG 1

CARINA E (DK)

Carina E (DK)		1.6		4	.92-	4A-FE Cat. Lean Burn	1,3	BKR6EP-13	2550		
Carina E (DK)		1.6		4	.92-	4A-FE Cat.	0,8	BKR6EYA	2249		LPG 1
Carina E (DK)		1.8		4	.92-	7A-FE Cat. Lean Burn	1,3	BKR6EP-13	2550		
Carina E (DK)		2.0		4	.92-	3S-FE Cat. Lean Burn	1,1	BKR6EP-11	2978		LPG 1
Carina E (DK)		2.0		4	.92-	3S-FE Cat.	1,1	BKR6EYA-11	4073		LPG 1

CARINA II

Carina II (AT171,177,ST171)		1.6	66	4	.87- .92	4A-F Cat.	0,8	BCRE527Y	2074		
Carina II (AT171,177,ST171)		1.6	72	4	.90- .92	4A-FE, 4A-FE with EGR	0,8	BCPR5EY	1266		LPG 3
Carina II (AT171,177,ST171)		1.6	72	4	.90- .92	4A-FE Cat., 4A-FE without EGR	1,1	BCPR6EIX-11	4919		LPG 3
Carina II (AT171,177,ST171)		2.0	89	4	.88- .92	3S-F	1,1	BCPR6EY-11	3720		LPG 3
Carina II (AT171,177,ST171)		2.0	98	4	.88- .92	3S-FE Cat.	1,1	BCPR6EY-11	3720		LPG 3

CELICA

Celica (AT180,ST182,184,185)		1.6	77	4	.90- .94	4A-FE	0,8	BCPR5EY	1266		LPG 3
Celica (AT200,ST202,204,205)		1.8	85	4	03.94-	7A-FE	0,8	BKR6EYA	2249		LPG 1
Celica S (ZZT230)		1.8	105	4	08.99-	1ZZ-FE	1,1	BKR5EYA-11	2526	39	LPG 1
Celica (ZZT230,231)		1.8		4	08.99-	1ZZ-FE	1,1	BKR5EYA-11	2526	39	LPG 1
Celica (ZZT230,231)		1.8		4	08.99-	2ZZ-GE	1,1	IFR6T11	4589		
Celica (AT200,ST202,204,205)		2.0	95	4	.94-	3S-FE	1,1	BKR6EYA-11	4073		LPG 1
Celica (AT180,200, ST182,184,185,202,204,205)		2.0	115	4	.90-	3S-GE Cat.	0,8	BKR6EP-8	2215		LPG 1
Celica 2.0 VVTi	ST182	2.0	118	4	09.89-10.93	3S-GE	0,8	BKR6EP-8	2215		LPG 1
Celica 2.0 VVTi	ST182	2.0	118	4	10.90-10.93	3S-GE	0,8	BKR6EP-8	2215		LPG 1
Celica (AT180,200, ST182,184,185,202,204,205)		2.0	129	4	03.94-	3S-GE	0,8	BKR6EP-8	2215		LPG 1
Celica 2.0 VVTi	ST202	2.0	129	4	08.94-08.99	3S-GE	0,8	BKR6EP-8	2215		LPG 1
Celica		2.0		4	.90- .99	3S-GTE	0,8	BKR6EP-8	2215		LPG 1
Celica (AT200)		2.0		4	.98-	3S-GE	0,8	BKR6EP-8	2215		LPG 1
Celica (ST202,204,205)		2.0		4	.98-	3S-GE	0,8	BKR6EP-8	2215		LPG 1
Celica (AT180,ST182,184,185)		2.2	100	4	.91-	5S-FE Cat.	1,1	BKR6EP-11	2978		LPG 1
Celica (AT200)		2.2		4	.98-	5S-FE	1,1	BKR6EP-11	2978		LPG 1
Celica (ST202,204,205)		2.2		4	.98-	5S-FE	1,1	BKR6EP-11	2978		LPG 1

CELICA TURBO

Celica Turbo (AT200,ST202,204,205)		2.0	150	4	.90-	3S-GTE	0,8	BKR6EP-8	2215		LPG 1
------------------------------------	--	-----	-----	---	------	--------	-----	----------	------	--	-------

C-HR

C-HR 2.0 VVTi	ZGX10	2.0	109	4	11.16-	3ZR-FAE	1,1	DF6H-11B	5989		
---------------	-------	-----	-----	---	--------	---------	-----	----------	------	--	--





l kW C
Y
I



Stock-N°

VLINE

LPG/CNG

TOYOTA

COROLLA

Corolla (EE80,90,97,100,105, AE82,92,95,101)	1,3	55	4	.86- .92	2E	1,1	BPR6EY-11	4228	10	LPG 2
Corolla (EE90,97,AE92,95)	1,3	55	4	.90- .92	2E-E	0,8	BPR5EY	2828	9	LPG 2
Corolla 1.3 EE110	1,3	55	4	05.97-10.01	2E	1,1	BPR5EY-11	3028		LPG 2
Corolla (EE105)	1,3	63	4	07.97- .07	2E	0,8	BPR6EY	6427		LPG 2
Corolla Estate/Wagon 1.3 EFI EE101	1,3	65	4	07.92-09.95	4E-FE	0,8	BKR5EYA	2087		LPG 1
Corolla 1.3 VVTi NRE180	1,3	73	4	06.13-12.18	1NR-FE	1,1	DF6H-11B	5989		
Corolla 1.3 VVTi NRE180	1,3	73	4	06.13-12.18	1NR-FE	1,1	ILKAR7B11	4912		
Corolla EE100, EE101, EE105, AE101, AE102	1,3		4	.92- .97	4E-FE	0,8	BKR5EYA	2087		LPG 1
Corolla EE100, EE101, EE105, AE101, AE102	1,3		4	.93- .97	2E	0,8	BPR6EY	6427		LPG 2
Corolla EE100, EE101, EE105, AE101, AE102	1,3		4	.94- .07	2E	0,8	BPR6EY	6427		LPG 2
Corolla EE100, EE101, EE105, AE101, AE102	1,3		4	.95-12.99	2E without Cat.	1,1	BPR5EY-11	3028		LPG 2
Corolla	1,3		4	07.97-12.99	4E-FE	1,1	BKR5EYA-11	2526	39	LPG 1
Corolla AE110, AE111, AE112, AE115	1,3		4	.98-12.99	4E-FE	1,1	BKR5EKB-11	3967		
Corolla EE110, EE111	1,3		4	.98-12.99	4E-FE (16V DOHC)	1,1	BKR5EKB-11	3967		
Corolla AE110, AE111, AE112, AE115	1,3		4	.98-12.99	2E	0,8	BPR6EY	6427		LPG 2
Corolla EE110, EE111	1,3		4	.98-12.99	2E	0,8	BPR6EY	6427		LPG 2
Corolla EE110, EE111, AE110, AE112, AE115, ZZE111, ZZE112	1,3		4	01.00- .07	4E-FE	1,1	BKR5EKB-11	3967		
Corolla EE110, 111, AE110-112, 115, ZZE111, 112	1,3		4	01.00- .07	2E	0,8	BPR6EY	6427		LPG 2
Corolla NZE120, 121	1,3		4	10.01- .07	2NZFE	1,1	BKR5EYA-11	2526	39	LPG 1
Corolla ZZE120, 121, 122, 123	1,3		4	10.01- .07	2NZFE	1,1	BKR5EYA-11	2526	39	LPG 1
Corolla	1,3		4	- .00	2A (8V SOHC)	0,8	BPR5EY	2828	9	LPG 2
Corolla 1.33 NRE150	1,33	74	4	10.08-	1NR-FE	1,1	ILKAR7B11	4912		
Corolla EE100, 101, 105, AE101, 102	1,4	65	4	.92- .94	4E-FE	0,8	BKR6EYA	2249		LPG 1
Corolla EE110, 111, AE110-112, 115, ZZE111, 112	1,4	71	4	01.00- .07	4ZZFE	1,1	BKR5EYA-11	2526	39	LPG 1





kw
C
Y
I



Stock-N°

VLINE

LPG/CNG

TOYOTA

COROLLA

Corolla	NZE120, 121 ZZE120, 121, 122, 123	1.4	71	4	01.02- .07	4ZZ-FE	1,1	BKR5EYA-11	2526	39	LPG 1
Corolla 1.4 VVTi	ZZE150	1.4	71	4	11.06-11.13	4ZZ-FE	1,1	BKR5EYA-11	2526	39	LPG 1
Corolla	EE110, 111, AE110, 111, 112, 115	1.4		4	01.98- .07	4E-FE	1,1	BKR5EKB-11	3967		
Corolla	NZE120, 121	1.4		4	10.01- .07	4ZZ-FE	1,1	BKR5EYA-11	2526	39	LPG 1
Corolla	ZZE120, 121, 122, 123	1.4		4	10.01- .07	4ZZ-FE	1,1	BKR5EYA-11	2526	39	LPG 1
Corolla		1.4		4	- .91		0,9	BPR5ES	7422	6	LPG 2
Corolla	AE110, 111, 112, 115	1.5		4	.98-12.99	5A-FE	1,1	BKR5EYA-11	2526	39	LPG 1
Corolla	EE110, 111	1.5		4	.98-12.99	5A-FE	1,1	BKR5EYA-11	2526	39	LPG 1
Corolla	EE110, 111, AE110-112, 115, ZZE111, 112	1.5		4	01.00- .07	5A-FE	1,1	BKR5EYA-11	2526	39	LPG 1
Corolla	NZE120, 121	1.5		4	10.01- .07	1NZ-FE	1,1	BKR5EYA-11	2526	39	LPG 1
Corolla	ZZE120, 121, 122, 123	1.5		4	10.01- .07	1NZ-FE	1,1	BKR5EYA-11	2526	39	LPG 1
Corolla	EE90, 97, 100, 101, 105, AE92, 95, 101, 102	1.6	66	4	.87-12.99	4A-F	0,8	BCRE527Y	2074		
Corolla	EE90, 97, AE92, 95	1.6	77	4	.89- .91	4A-FE Cat.	0,8	BCPR5EY	1266		LPG 3
Corolla		1.6	81	4	07.97- .07	4A-FE	1,1	BKR5EYA-11	2526	39	LPG 1
Corolla	EE110, 111, AE110-112, 115, ZZE111, 112	1.6	81	4	01.00- .07	3ZZ-FE	1,1	BKR5EYA-11	2526	39	LPG 1
Corolla	NZE120, 121	1.6	81	4	10.01- .07	3ZZ-FE	1,1	BKR5EYA-11	2526	39	LPG 1
Corolla	ZZE120, 121, 122, 123	1.6	81	4	10.01- .07	3ZZ-FE	1,1	BKR5EYA-11	2526	39	LPG 1
Corolla	ZZE121	1.6	81	4	11.01- .07	3ZZ-FE	1,1	BKR5EYA-11	2526	39	LPG 1
Corolla	EE100, 101, 105, AE101, 102	1.6	84	4	.92- .94	4A-FE	0,8	BKR6EYA	2249		LPG 1
Corolla	EE90, 97, AE92, 95	1.6	85	4	.90-	4A-GE Cat.	0,8	BKR6EP-8	2215		LPG 1
Corolla		1.6	85	4	.93-	4A-GE Cat.	0,8	BKR6EYA	2249		LPG 1
Corolla 1.6 VVTi	ZRE151	1.6	90	4	05.10-07.14	1ZR-FE	1,1	ILKAR7B11	4912		
Corolla 1.6 VVTi	ZRE181	1.6	90	4	06.13-12.18	1ZR-FE	1,1	ILKAR7B11	4912		
Corolla 1.6 VVTi	ZRE210	1.6	90	4	01.19-	1ZR-FAE, 1ZR-FE	1,1	DF6H-11B	5989		
Corolla 1.6	ZRE151	1.6	91	4	11.06-12.08	1ZR-FE	1,1	ILKAR7B11	4912		
Corolla 1.6	ZRE151	1.6	97	4	01.09-	1ZR-FAE, 1ZR-FE	1,1	ILKAR7B11	4912		
Corolla 1.6 VVTi	ZRE181	1.6	97	4	06.13-12.18	1ZR-FAE	1,1	ILKAR7B11	4912		
Corolla 1.6 VVTi	ZRE210	1.6	97	4	01.19-	1ZR-FAE, 1ZR-FE	1,1	DF6H-11B	5989		
Corolla 1.6 VVTi	ZRE151	1.6	100	4	03.07-12.10	1ZR-FE	1,1	ILKAR7B11	4912		
Corolla	EE100, 101, 105, AE101, 102	1.6		4	.95-12.99	4A-FE	0,8	BKR6EYA	2249		LPG 1
Corolla	AE110, 111, 112, 115	1.6		4	.98-12.99	4A-F	0,8	BCRE527Y	2074		
Corolla	EE110, 111	1.6		4	.98-12.99	4A-F	0,8	BCRE527Y	2074		
Corolla	AE110, 111, 112, 115	1.6		4	.98-12.99	4A-FE	0,8	BKR6EYA	2249		LPG 1
Corolla	EE110, 111	1.6		4	.98-12.99	4A-FE	0,8	BKR6EYA	2249		LPG 1





l kW C
Y
I



Stock-N°

VLINE

LPG/CNG

TOYOTA

COROLLA

Corolla	EE110, 111, AE110-112, 115, ZZE111, 112	1.6		4	01.00- .07	4A-F	0,8	BCRE527Y	2074		
Corolla	EE110, 111, AE110-112, 115, ZZE111, 112	1.6		4	01.00- .07	4A-FE	0,8	BKR6EYA	2249		LPG 1
Corolla Spacio	AE111	1.6		4	01.00- .07	4A-FE	0,8	BKR6EYA	2249		LPG 1
Corolla	NZE120, 121	1.8	99	4	10.01- .07	1ZZ-FE	1,1	BKR5EYA-11	2526	39	LPG 1
Corolla	ZZE120, 121, 122, 123	1.8	99	4	10.01- .07	1ZZ-FE	1,1	BKR5EYA-11	2526	39	LPG 1
Corolla 1.8 VVTi	ZRE182	1.8	103	4	06.13-12.18	2ZR-FE	1,1	ILKAR7B11	4912		
Corolla (NZE120,121)	NZE120, 121	1.8	141	4	10.01- .07	2ZZ-GE	1,1	IFR6T11	4589		
Corolla (ZZE120,121,122,123)	ZZE120, 121, 122, 123	1.8	141	4	10.01- .07	2ZZ-GE	1,1	IFR6T11	4589		
Corolla (ZZE123) Sport	ZZE123 Sport	1.8	141	4	.02- .07	2ZZ-GE	1,1	IFR6T11	4589		
Corolla (ZZE123) Sport	ZZE123 Sport	1.8	160	4	10.05-02.07	2ZZ-GE	1,1	IFR6T11	4589		
Corolla (EE100,101,105,AE101,102)	EE100, 101, 105, AE101, 102	1.8		4	.93-12.99	7A-FE	0,8	BKR6EYA	2249		LPG 1
Corolla (AE110,111,112,115)	AE110, 111, 112, 115	1.8		4	.98-12.99	7A-FE	0,8	BKR6EYA	2249		LPG 1
Corolla (EE110,111)	EE110, 111	1.8		4	.98-12.99	7A-FE	0,8	BKR6EYA	2249		LPG 1
Corolla (EE110,111,AE110-112,115,ZZE111,112)	EE110, 111, AE110-112, 115, ZZE111, 112	1.8		4	01.00-	7A-FE	0,8	BKR6EYA	2249		LPG 1

COROLLA 4WD

Corolla 4WD		1.6	84	4	.93-	4A-FE	0,8	BCPR5EY	1266		LPG 3
Corolla 4WD		1.6		4	.95-	4A-FE	0,8	BCPR5EY	1266		LPG 3

COROLLA SPACIO

Corolla Spacio	AE111	1.6		4	01.01- .07	4A-FE	0,8	BKR6EYA	2249		LPG 1
----------------	-------	-----	--	---	------------	-------	-----	---------	------	--	-------

COROLLA VERSO

Corolla Verso	ZZE121, 122	1.6		4	09.01- .07	3ZZ-FE	1,1	BKR5EYA-11	2526	39	LPG 1
Corolla Verso	ZNR10	1.6		4	08.05- .07	3ZZ-FE	1,1	BKR5EYA-11	2526	39	LPG 1
Corolla Verso	ZNR10	1.8	99	4	08.05- .07	1ZZ-FE	1,1	BKR5EYA-11	2526	39	LPG 1
Corolla Verso	ZZE121, 122	2.0		4	09.01- .07	1ZZ-FE	1,1	BKR5EYA-11	2526	39	LPG 1

CORONA

Corona	AT171, 177, ST171	1.6	66	4	.88- .92	4A-F Cat.	0,8	BCRE527Y	2074		
Corona	AT171, 177, ST171	1.6	72	4	.90- .92	4A-FE	1,1	BCPR6EIX-11	4919		LPG 3
Corona	AT171, 177, ST171	1.6	75	4	.90- .92	4A-FE	0,8	BCPR5EY	1266		LPG 3
Corona	AT220, 221, ST220	1.6	81	4	04.98-	4A-FE	1,3	BKR6EP-13	2550		
Corona	AT190, ST191	1.6		4	.93-	4A-FE	1,1	BKR5EYA-11	2526	39	LPG 1
Corona	ST210, AT210	1.6		4	01.00-	4A-FE	0,8	BKR6EYA	2249		LPG 1
Corona	AZT220	1.6		4	01.02-	3ZZ-FE	1,1	BKR5EYA-11	2526	39	LPG 1
Corona	ST220	1.6		4	01.02-	3ZZ-FE	1,1	BKR5EYA-11	2526	39	LPG 1
Corona	ZZT220, 221	1.6		4	01.02-	3ZZ-FE	1,1	BKR5EYA-11	2526	39	LPG 1
Corona	AT220, 221, ST220	1.8	81	4	01.98-	7A-FE	1,3	BKR6EP-13	2550		
Corona	AZT220	1.8		4	01.02-	1ZZ-FE	1,1	BKR5EYA-11	2526	39	LPG 1





l kW C Y I



Stock-N°

VLINE

LPG/CNG

TOYOTA

CORONA

Corona	ST220	1.8		4	01.02-	1ZZ-FE	1,1	BKR5EYA-11	2526	39	LPG 1
Corona	ZZT220, 221	1.8		4	01.02-	1ZZ-FE	1,1	BKR5EYA-11	2526	39	LPG 1
Corona	AT171, 177, ST171	2.0	89	4	- .92	3S-FE Cat.	1,1	BCPR6EY-11	3720		LPG 3
Corona	AT220, 221, ST220	2.0	94	4	01.98-	3S-FE	1,1	BKR6EKP-11	3452		
Corona	AT190, 191, ST191	2.0	98	4	.93-	3S-FE	1,1	BKR6EYA-11	4073		LPG 1
Corona	AT171, 177, ST171	2.0	116	4	.92-	3S-GE	0,8	BKR6EP-8	2215		LPG 1
Corona	ST210, AT210	2.0		4	01.00-	3S-FE	1,1	BKR6EKB-11	3583		
Corona	AZT220	2.0		4	01.02-	3S-FE	1,1	BKR6EKB-11	3583		
Corona	ST220	2.0		4	01.02-	3S-FE	1,1	BKR6EKB-11	3583		
Corona	ZZT220, 221	2.0		4	01.02-	3S-FE	1,1	BKR6EKB-11	3583		
Corona	AT171, 177, ST171	2.0		4	- .92	3S-F	1,1	BCPR6EY-11	3720		LPG 3

CRESSIDA

Cressida		2.0	73	4	.85-	21R	0,8	BPR5EY	2828	9	LPG 2
Cressida		2.0	99	4	.90-	1G-FE	0,8	BKR6EYA	2249		LPG 1
Cressida		2.8	92	6	.84-	5M-E	0,8	BPR5EY	2828	9	LPG 2
Cressida		2.8	125	6	.85-	5M-GE	0,8	BPR6EY	6427		LPG 2
Cressida		3.0	142	6	.88-	7M-GE Cat.	1,1	BCPR5EIX-11	3306		LPG 3

CROWN

Crown		2.0		4	.93-	1G-FE	0,8	BKR6EYA	2249		LPG 1
Crown (GS151)		2.0		4	.98-	1G-FE	1,1	BKR5EYA-11	2526	39	LPG 1
Crown (JZS155)		2.0		4	.98-	1G-FE	1,1	BKR5EYA-11	2526	39	LPG 1
Crown		2.8		6	.86-	5M-GE	0,8	BPR5EY	2828	9	LPG 2
Crown (GS151)		2.9		6	.98-	2JZ-GE with 3way cat.	1,1	BKR5EKB-11	3967		
Crown (JZS155)		2.9		6	.98-12.99	2JZ-GE with 3way cat.	1,1	BKR5EKB-11	3967		
Crown (GS151)		2.9		6	.98-	2JZ-GE without 3way cat.	0,8	BKR6EYA	2249		LPG 1
Crown (JZS155)		2.9		6	.98-	2JZ-GE without 3way cat.	0,8	BKR6EYA	2249		LPG 1
Crown		3.0		6	.93-12.99	2JZ-GE	0,8	BKR6EYA	2249		LPG 1
Crown (JZS155)		3.0		6	01.00-	2JZ-GE	1,1	BKR5EKP-11	4302		

ECHO

Echo (SCP10,NCP10,11,12,13)		1.0		4	01.99-	1SZ-FE	0,8	BKR5EYA	2087		LPG 1
Echo Verso (NCP20,21,22)		1.3	63	4	08.99-	2NZ-FE	1,1	BKR5EYA-11	2526	39	LPG 1
Echo (NCP10,11,12,13, SCP10)		1.3		4	01.01-	2NZ-FE	1,1	BKR5EYA-11	2526	39	LPG 1
Echo (NCP10,11,12,13, SCP10)		1.5	78	4	01.01-12.01	1NZ-FE	1,1	BKR5EYA-11	2526	39	LPG 1
Echo (NCP10,11,12,13, SCP10)		1.5	78	4	01.02-	1NZ-FE	0,8	BKR5EYA	2087		LPG 1
Echo (NCP20, 21, 22)		1.5	78	4	01.02-	1NZ-FE	0,8	BKR5EYA	2087		LPG 1

ESTIMA

Estima 2.4 VVTi	ACR30	2.4	125	4	02.00-01.06	2AZFE	1,1	IFR6T11	4589		
-----------------	-------	-----	-----	---	-------------	-------	-----	---------	------	--	--

FUN CARGO

FunCargo 1.5 VVTi	NCP21	1.5	77	4	03.00-11.04	1NZFE	0,8	BKR5EYA	2087		LPG 1
-------------------	-------	-----	----	---	-------------	-------	-----	---------	------	--	-------

HIACE

Hiace		1.8		4	.95-	2Y without Cat.	0,8	BPR5EY	2828	9	LPG 2
Hiace (RZH102,103,104,109,112-115,119,125)		2.0	74	4	.90- .98	1R-Z	0,8	BPR5EY	2828	9	LPG 2
Hiace (RZH102-105,112-115,125,135,153,155)		2.0		4	.98-	1R-Z	0,8	BP5EY	7327		LPG 2





e kW C Y I



Stock-N°

VLINE

LPG/CNG

TOYOTA**HIACE**

Hiace (RZH102,103,104,109,112-115,119,125)	2.4	88	4	.90-	2R-ZE	1,1	BPR5EP-11	3971		
Hiace (RZH102,103,104,109,112-115,119,125)	2.4		4	.90-	2R-Z	0,8	BP5EY	7327		LPG 2
Hiace (RZH102-105,112-115,125,135,153, 155	2.4		4	.98-	2RZ	0,8	BP5EY	7327		LPG 2
Hiace (RZH102-105,112-115,125,135,153,155	2.4		4	.98-	2RZE	1,1	BPR5EP-11	3971		
Hiace (RCH12,13,19,22,23,29)	2.4		4	01.00-	2RZE	1,1	BPR5EP-11	3971		
Hiace (RCH12,13,19,22,23,29)	2.7	105	6	01.00- .03	3RZFE	0,8	IFR5T-8N	3508		
Hiace (RCH 13,19,23,29)	2.7		4	01.04-	3RZFE	1,1	IFR5T11	4996		
Hiace 2.7	RCH19	2.7	106	4	07.98-06.05	3RZFE	1,1	IFR5T11	4996	
Hiace 2.7 VVTi	TRH203, TRH213, TRH223, TRH201, TRH221	2.7	111	4	01.05-05.19	2TR-FE	1,1	ILFR6T11	4904	
Highlander 2.7 VVTi	ASU50	2.7	138	4	09.14-	1AR-FE	1,1	ILFR5T11	96779	ILFR6T11
Highlander 3.5 Dual VVTi/VVTi	GSU55	3.5	183	6	09.14-10.16	2GR-FE, 2GR-FKS	1,1	DILFR6D11	6176	

HILUX

Hilux	1.8		4	.95-	2Y	0,8	BP5EY	7327		LPG 2
Hilux (TGN10,11,15,16,26,36)	2.0	100	4	07.05-	1TR-FE	1,1	LFR6C-11	5788	48	
Hilux	2.0		4	.95-	3Y	0,8	BP5EY	7327		LPG 2
Hilux (RZN142,144,147-149,154,168,169,173,174,193)	2.0		4	01.01-	1R-Z	0,8	BP5EY	7327		LPG 2
Hilux (VZN 167, 172)	2.0		4	01.01-	1R-Z	0,8	BP5EY	7327		LPG 2
Hilux (RZN142,144,147-149,154,168,169,173,174,193)	2.0		4	01.01-	1RZE	0,8	BPR5EY	2828	9	LPG 2
Hilux	2.2		4	.95-	4Y	0,8	BP5EY	7327		LPG 2
Hilux	2.4	84	4	.88-	22R-E Cat	0,8	BPR5EY	2828	9	LPG 2
Hilux	2.4		4	.88-	22R	0,8	BPR5EY	2828	9	LPG 2
Hilux (VZN 167, 172)	2.4		6	01.01-	2RZFE	0,8	BKR5EYA	2087		LPG 1
Hilux (RZN142,144,147-149,154,168,169,173,174,193)	2.4		6	01.01-	2RZFE	0,8	BKR5EYA	2087		LPG 1
Hilux (TNG10,11,15,16,26,36)	2.7	118	4	07.05-	2TR-FE	1,1	LFR6C-11	5788	48	
Hilux	2.7		6	.96-	3RZFE	0,8	BKR5EYA	2087		LPG 1
Hilux (RZN142,144,147-149,154,168,169,173,174,193)	2.7		6	01.01-	3RZF, 3RZFE	0,8	BKR5EYA	2087		LPG 1
Hilux (GGN15,25)	4.0	175	6	07.05-	1GR-FE	1,1	LFR6C-11	5788	48	
Hilux (GRN215W)	4.0		6	08.05-	1GR-FE	1,1	LFR6C-11	5788	48	

IPSUM

Ipsum 2.0	SXM10	2.0	99	4	09.96-05.01	3S-FE	1,1	BKR6EKB-11	3583	
Ipsum 2.0	SXM10	2.0	99	4	09.96-05.01	3S-FE	1,1	BKR6EKP-11	3452	

IQ

iQ 1.0 VVT-i (KGJ10)	1.0	50	3	11.08-	1KR-FE	1,1	ILFR5T11	96779		ILFR6T11
iQ 1.3 (NGJ10)	1.33	72	4	05.09-	1NR-FE	1,1	ILKAR7B11	4912		

LAND CRUISER

Land Cruiser	2.4	77	4	-12.96	22R-E	0,8	BPR5EY	2828	9	LPG 2
Land Cruiser (RZJ90,95, VZJ90,95)	2.7		6	05.96-	3RZF, 3RZFE	0,8	BKR5EYA	2087		LPG 1
Land Cruiser (RZJ120,125)(GRJ120,125)	2.7		4	01.03-	3RZFE without 3way cat.	0,8	BKR5EYA	2087		LPG 1
Land Cruiser (RZJ120,125)(GRJ120,125)	2.7		4	01.03-	3RZFE with 3way cat.	1,1	BKR5EYA-11	2526	39	LPG 1
Land Cruiser (TRJ120,125)(GRJ120,125)	2.7		6	01.05-	2TR-FE	1,1	ILFR6T11	4904		





kw
C
Y
I



Stock-N°

VLINE

LPG/CNG

TOYOTA

LAND CRUISER

Land Cruiser (RZJ90,95, VZJ90,95)		3.4	131	6	05.96-	5VZ-FE	1,1	BKR5EKB-11	3967		
Land Cruiser (FJ62,70,73,75,RJ70)		4.0	107	6	.88-	3F	0,8	BPR4EY	2128		LPG 2
Land Cruiser (FJ62,70,73,75,RJ70)		4.0	115	6	01.90-08.92	3F-E Cat.	1,1	BPR5EY-11	3028		LPG 2
Land Cruiser (RZJ120,125)(GRJ120,125)		4.0	183	6	.02-	1GR-FE	1,1	LFR6C-11	5788	48	
Land Cruiser 150 (J15) 4.0 V6 VVTi		4.0	183	6	01.10-	1GR-FE	1,1	ILFR6T11	4904		
Land Cruiser Prado 4.0 VVTi	GRJ150	4.0	183	6	11.12-	1GR-FE	1,1	ILFR5T11	96779		ILFR6T11
Land Cruiser 4.0 VVTi	GRJ150	4.0	202	6	01.10-	1GR-FE	1,1	ILFR5T11	96779		ILFR6T11
Land Cruiser 4.0 VVTi	GRJ150	4.0	202	6	01.10-	1GR-FE	1,1	ILFR6T11	4904		
Land Cruiser 150 (J15) 4.0 V6 Dual VVTi		4.0	205	6	01.10-	1GR-FE	1,1	ILFR6T11	4904		
Land Cruiser 4.0 VVTi	GRJ150	4.0	205	6	01.10-	1GR-FE	1,1	ILFR5T11	96779		ILFR6T11
Land Cruiser Prado 4.0 VVTi	GRJ125	4.0	207	6	01.03-07.09	1GR-FE	1,1	LFR6C-11	5788	48	
Land Cruiser 150 4.0 V6 VVTi	J15	4.0	207	6	01.10-	1GR-FE	1,1	ILFR6T11	4904		
Land Cruiser Prado 4.0 VVTi	GRJ150	4.0	207	6	01.10-	1GR-FE	1,1	ILFR5T11	96779		ILFR6T11
Land Cruiser	TRJ120, 125, GRJ120, 125	4.0		6	01.05-	1GR-FE	1,1	LFR6C-11	5788	48	
Land Cruiser	20W, 121W	4.0		6	08.05-	1GR-FE	1,1	LFR6C-11	5788	48	
Land Cruiser		4.2	88	6	.81-	2F	0,8	BPR4EY	2128		LPG 2
Land Cruiser 80 4.5	FZJ80	4.5	215	6	08.92-01.98	1FZ-FE	0,8	BKR5EYA	2087		LPG 1
Land Cruiser		4.5		6	.93-	1FZ-FE	0,8	BKR5EYA	2087		LPG 1
Land Cruiser	FZJ80	4.5		6	.96-	1FZF	0,8	BKR5EYA	2087		LPG 1
Land Cruiser	FZJ100, 105	4.5		6	.98-12.99	1FZ-FE	1,1	BKR5EKB-11	3967		
Land Cruiser	UZJ100	4.5		6	.98-12.99	1FZ-FE	1,1	BKR5EKB-11	3967		
Land Cruiser	FZJ70, 73, 75	4.5		6	.98-12.99	1FZF, 1FZFE	0,8	BKR5EYA	2087		LPG 1
Land Cruiser	FZJ71, 74, 78, 79	4.5		6	01.00-	1FZ-FE	1,1	BKR5EKB-11	3967		
Land Cruiser	UZJ100, FZJ100, 105	4.5		6	01.01-	1FZ-FE	1,1	BKR5EKB-11	3967		
Land Cruiser	FZJ100, 105	4.5		6	01.02-	1FZ-FE	1,1	BKR5EKB-11	3967		
Land Cruiser	UZJ100	4.5		6	01.02-	1FZ-FE	1,1	BKR5EKB-11	3967		
Land Cruiser 200 4.6 VVTi	URJ202	4.6	227	8	01.12-06.17	1UR-FE	1,1	ILFR6T11	4904		
Land Cruiser V8 4.6 VVTi	URJ202	4.6	234	8	01.12-	1UR-FE	1,1	ILFR6T11	4904		
Land Cruiser	URJ202W	4.6		8	.09-	1UR-FE	1,1	LFR6AIX-11	6619		
Land Cruiser 4.7 V8	FZJ100, 105	4.7	173	8	01.98-	2UZFE	1,1	IFR6T11	4589		
Land Cruiser 4.7 V8	UZJ100	4.7	173	8	01.98-	2UZFE	1,1	IFR6T11	4589		
Land Cruiser 4.7 V8	UZJ200	4.7	212	8	08.07-	2UZFE	1,1	IFR6T11	4589		
Land Cruiser 4.7 V8	UZJ200	4.7	232	8	01.08-	2UZFE	1,1	IFR6T11	4589		
Land Cruiser 4.7 V8	UZJ100, FZJ100, 105	4.7		8	01.01-	2UZFE with 3way cat.	1,1	IFR6T11	4589		

LITEACE

Liteace (KR41,42)		1.5		4	.98-	5K	0,8	BPR5EY	2828	9	LPG 2
Liteace (SR40)		1.5		4	.98-	5K	0,8	BPR5EY	2828	9	LPG 2
Liteace (KM30,36,37, YM30,35,40,41)		1.8		4	.89-	2Y-C	0,8	BP5EY	7327		LPG 2
Liteace (KM30,36,37, YM30,35)		1.8		4	.90-	2Y Cat., 2Y-CU Cat.	0,8	BP5EY	7327		LPG 2
Liteace (KM30,36,37, YM30,35)		1.8		4	.90-	2Y-C Cat.	1,1	BPR5EP-11	3971		
Liteace (KR41,42)		1.8		4	.98-	7K	0,8	BPR5EY	2828	9	LPG 2
Liteace (SR40)		1.8		4	.98-	7K	0,8	BPR5EY	2828	9	LPG 2
Liteace (KR42,SR40)		1.8		4	01.00-	7K-E	1,1	BPR5EY-11	3028		LPG 2
Liteace (KM30,36,37, YM30,35,40,41)		2.0		4	.93-	3Y	0,8	BP5EY	7327		LPG 2





l kW C
Y
I



Stock-N°

VLINE

LPG/CNG

TOYOTA

LITEACE

Liteace (KR41,42)	2.0		4	.98-	3S-FE	1,1	BKR6EKB-11	3583		
Liteace (SR40)	2.0		4	.98-	3S-FE	1,1	BKR6EKB-11	3583		
Liteace	2.2		4	.93-	4Y-E	1,1	BPR5EP-11	3971		

MODEL F

Model F (YR21,22,31)	2.2	73	4	08.85-	4Y-EC Cat.	1,1	BPR5EP-11	3971		
Model F	2.2		4	08.85-	4Y-E Cat.	1,1	BPR5EP-11	3971		
Model F	2.2		4	08.85-	4Y-EC	0,8	BPR5EY	2828	9	LPG 2
Model F	2.2		4	.90-	4Y-E	0,8	BPR5EY	2828	9	LPG 2

MR 2

MR2 (ZZW30)	1.8	103	4	12.99-	1ZZFE	1,1	BKR5EYA-11	2526	39	LPG 1
MR2 2.0 SW20	2.0	88	4	12.89-08.92	3S-FE	1,1	BKR6EY-11	4368		LPG 1
MR2 (SW20)	2.0	115	4	.90- .93	3S-GE Cat.	0,8	BKR6EP-8	2215		LPG 1
MR2 (SW20)	2.0	118	4	.89- .92	3S-GE	0,8	BKR6EYA	2249		LPG 1
MR2 (SW20)	2.0	129	4	.94-	3S-GE	0,8	BKR6EP-8	2215		LPG 1
MR2 (SW20)	2.0		4	.93-	3S-GTE	0,8	BKR6EP-8	2215		LPG 1
MR2 (SW20)	2.2	89	4	.90-	3S-FE Cat.	1,1	BKR6EYA-11	4073		LPG 1
MR2	2.2		4	.93-	5S-FE	1,1	BKR6EP-11	2978		LPG 1

PASEO

Paseo (EL54)	1.5	66	4	07.95-12.97	5E-FE (only Europe)	0,8	BKR5EYA	2087		LPG 1
Paseo (EL54)	1.5		4	01.98-07.99	5E-FE (only Europe)	1,1	BKR5EP-11	3440		LPG 1

PICNIC

Picnic 2.0 SXM10	2.0	90	4	06.00-12.01	3S-FE	1,1	BKR6EKB-11	3583		
Picnic 2.0 SXM10	2.0	94	4	08.96-05.00	3S-FE	1,1	BKR6EKB-11	3583		
Picnic (SXM10)	2.0	94	4	09.96-09.01	3S-FE	1,1	BKR6EKP-11	3452		
Picnic (ACM20)	2.0	110	4	05.01-	1AZFE	1,1	IFR6T11	4589		

PREVIA

Previa (TCR10,11,20,21)	2.4	97	4	05.90- .00	2TZFE Cat.	1,1	BKR5EP-11	3440		LPG 1
Previa (TCR10,11,20,21)	2.4	97	4	05.90-	2TZFE 3 way Cat.	0,8	BKR5EYA	2087		LPG 1
Previa (ACR30,50)	2.4	115	4	03.00-	2AZFE	1,1	IFR6T11	4589		
Previa (TCR10,11,20,21)	2.4		4	.96-	2TZFE without Cat.	0,8	BKR5EYA	2087		LPG 1

PRIUS

Prius (Hybrid) (NHW11)	1.5	53	4	05.00- .03	1NZFXE	1,1	IFR5T11	4996		
Prius (Hybrid) (NHW20)	1.5	57	4	.03- .09	1NZFXE	1,1	IFR5T11	4996		
Prius (ZVW30)	1.8	72	4	04.09-	2ZR-FXE	1,1	ILKAR7B11	4912		
Prius PHV 1.8 Plug-In Hybrid ZVW35	1.8	73	4	01.12-	2ZR-FXE	1,1	DF6H-11B	5989		

PRIUS PLUS

Prius Plus 1.8 Hybrid (ZVW40)	1.8	73	4	03.12-	2ZR-FXE	1,1	ILKAR7B11	4912		
-------------------------------	-----	----	---	--------	---------	-----	-----------	------	--	--

RACTIS

Ractis 1.3 VVTi NSP120	1.3	70	4	12.13-04.14	1NR-FE	1,1	DF6H-11B	5989		
------------------------	-----	----	---	-------------	--------	-----	----------	------	--	--

RAV 4

RAV 4 (ZCA25,26, ACA20,21,22,23)	1.8	92	4	05.00-	1ZZFE	1,1	BKR5EYA-11	2526	39	LPG 1
RAV 4 (SXA10,11)	2.0	95	4	06.94-09.97	3S-FE	1,1	BKR6EKB-11	3583		
RAV 4 (SXA10,11)	2.0	95	4	10.97-06.00	3S-FE	1,1	BKR6EKP-11	3452		
RAV 4 2.0 VVTi ZSA42	2.0	105	4	12.12-	3ZR-FE	1,1	DF6H-11B	5989		
RAV 4 2.0 VVTi ZSA30, ZSA35	2.0	109	4	03.09-06.13	3ZR-FAE	1,1	ILKAR7B11	4912		





kw C
Y
I



Stock-Nº

VLINE

LPG/CNG

TOYOTA

RAV 4

RAV 4 2.0 VVTi	ZSA44	2.0	112	4	04.15-	3ZR-FAE	1,1	DF6H-11B	5989		
RAV 4 (ZSA30 / ZSA35)	ZSA30, ZSA35	2.0	116	4	12.08-	3ZR-FAE	1,1	ILKAR7B11	4912		
RAV 4	ZCA25, ZCA26, ACA20, ACA21, ACA22, ACA23	2.0		4	05.00-	1AZ-FE	1,1	IFR6T11	4589		
RAV 4	ACA30, ACA33, ACA38	2.0		4	11.05-01.07	1AZ-FE	1,1	IFR6T11	4589		
RAV 4	ACA30, ACA31, ACA33, ACA38	2.0		4	01.07-	1AZ-FE	1,1	IFR6T11	4589		
RAV 4	ACA31, ACA33, ACA38	2.4	125	4	11.05-	2AZ-FE	1,1	IFR6T11	4589		
RAV 4	ZCA25, ZCA26, ACA20, ACA21, ACA22, ACA23	2.4		4	01.04-	2AZ-FE	1,1	IFR6T11	4589		
RAV 4	ACA31W, ACA36W	2.4		4	11.05-	2AZ-FE	1,1	IFR6T11	4589		
RAV 4	ACA30, ACA31, ACA33, ACA38	2.4		4	01.07-	2AZ-FE	1,1	IFR6T11	4589		
RAV 4 2.5 VVTi	ASA42	2.5	132	4	12.12-11.18	2AR-FE	1,1	ILFR5T11	96779		ILFR6T11
RAV 4 2.5 VVTi	ASA44	2.5	132	4	12.12-	2AR-FE	1,1	ILFR5T11	96779		ILFR6T11

STARLET

Starlet (EP70,EP71,EP76,EP80,EP81)		1.0	40	4	.85- .92	1E	0,8	BPR6EY	6427		LPG 2
Starlet (EP80,81)		1.3	53	4	.88- .92	2E	1,1	BPR5EY-11	3028		LPG 2
Starlet (EP80,81)		1.3	53	4	.93-	2E	0,8	BPR6EY	6427		LPG 2
Starlet (EP70,71,76)		1.3	55	4	.88-	2E-C	1,1	BPR6EY-11	4228	10	LPG 2
Starlet (EP80,81)		1.3	55	4	.90-12.95	2E-E Cat.	0,8	BPR5EY	2828	9	LPG 2
Starlet		1.3	55	4	.93-	4A-FE	1,1	BKR5EYA-11	2526	39	LPG 1
Starlet (EP80,81)		1.3	55	4	02.96-03.97	4E-FE	0,8	BKR5EYA	2087		LPG 1
Starlet (EP90,91)		1.3	55	4	.98- .99	4E-FE	0,8	BKR5EYA	2087		LPG 1
Starlet		1.3		4	.95-	2E-E	0,8	BPR4EY	2128		LPG 2
Starlet (EP90,91)		1.3		4	.98-	2E	0,8	BPR6EY	6427		LPG 2

SUPRA

Supra (JZA80)		3.0	165	6	.93- .94	2JZ-GE	1,1	BKR5EP-11	3440		LPG 1
Supra Turbo (MA70)		3.0	175	6	.87- .92	7M-GTE	0,8	BCPR6EPN-8	5275		LPG 3
Supra V6 Biturbo (JZA80)		3.0	243	6	.93- .94	2JZ-GTE	1,1	BKR6EP-11	2978		LPG 1
Supra (MA70)		3.0		6	.90- .92	7M-GE	0,9	BCPR6EY	1146		LPG 3
Supra (JZA80)		3.0		6	.95- .95	2JZ-GE	1,1	BKR6EP-11	2978		LPG 1
Supra (JZA80)		3.0		6	.95-	2JZ-GTE	1,1	BKR6EP-11	2978		LPG 1
Supra (JZA80)		3.0		6	.96-	2JZ-GE	0,8	BKR6EYA	2249		LPG 1

TARAGO

Tarago		2.4	97	4	.90-	2TZFE	1,1	BKR5EP-11	3440		LPG 1
Tarago (ACR30)		2.4		4	03.00-	2AZ-FE	1,1	IFR6T11	4589		





l kW C
Y
I



Stock-N°

VLINE

LPG/CNG

TOYOTA

TERCEL

Tercel (EL50,53)	1.3		4	.98-	2E	0,8	BPR6EY	6427		LPG 2
Tercel (AL25)	1.5	50	4	.88-	3A-C Cat.	1,1	BPR5EY-11	3028		LPG 2
Tercel	1.5	52	4	.81- .91	3A	0,8	BPR5EY	2828	9	LPG 2
Tercel	1.5		4	.93-	3E-E	1,1	BPR5EY-11	3028		LPG 2
Tercel (EL50,53)	1.5		4	.98-	5E-FE	1,1	BKR5EKB-11	3967		

TOWNACE

Townace (KR41,42)	1.5		4	.98-	5K	0,8	BPR5EY	2828	9	LPG 2
Townace (SR40)	1.5		4	.98-	5K	0,8	BPR5EY	2828	9	LPG 2
Townace (KR41,42)	1.8		4	.98-	7K	0,8	BPR5EY	2828	9	LPG 2
Townace (SR40)	1.8		4	.98-	7K	0,8	BPR5EY	2828	9	LPG 2
Townace (KR42,SR40)	1.8		4	01.00-	7K-E	1,1	BPR5EY-11	3028		LPG 2
Townace (KR41,42)	2.0		4	.98-	3S-FE	1,1	BKR6EKB-11	3583		
Townace (SR40)	2.0		4	.98-	3S-FE	1,1	BKR6EKB-11	3583		

URBAN CRUISER

Urban Cruiser 1.3 (NSP110)	1.33	73	4	04.10-	1NR-FE	1,1	ILKAR7B11	4912		
Urban Cruiser 1.3 (NSP110)	1.33	74	4	01.09-	1NR-FE	1,1	ILKAR7B11	4912		

VERSO

Verso 1.6 VVTi	ZGR20	1.6	81	4	04.09-	1ZR-FAE	1,1	DF6H-11B	5989		
Verso (ZGR20)		1.6	81	4	04.09-	1ZR-FAE	1,1	ILKAR7B11	4912		
Verso 1.6 VVTi	ZGR20	1.6	81	4	04.09-08.18	1ZR-FAE	1,1	ILKAR7B11	4912		
Verso (ZGR20)		1.6	97	4	04.09-	1ZR-FAE	1,1	ILKAR7B11	4912		
Verso (ZGR21)		1.8	95	4	04.09-	2ZR-FAE	1,1	ILKAR7B11	4912		
Verso (ZGR21)		1.8	108	4	04.09-	2ZR-FAE	1,1	ILKAR7B11	4912		

VERSO S

Verso S 1.33 VVTi (NSP120)		1.33	73	4	11.10-	1NR-FE	1,1	ILKAR7B11	4912		
----------------------------	--	------	----	---	--------	--------	-----	-----------	------	--	--

VITZ

Vitz 1.0 VVTi	KSP130	1.0	51	3	07.14-	1KR-FE	1,1	DF6H-11B	5989		
---------------	--------	-----	----	---	--------	--------	-----	----------	------	--	--

YARIS

Yaris 1.0 16V(NCP10,11,12,13)		1.0	48	4	01.99-	1SZ-FE	0,8	BKR5EYA	2087		LPG 1
Yaris 1.0 16V (SCP10) (Japan production)		1.0	48	4	01.99-	1SZ-FE	0,8	BKR5EYA	2087		LPG 1
Yaris 1.0 16V(SCP10) France production		1.0	48	4	01.01-	1SZ-FE	1,1	BKR6EYA-11	4073		LPG 1
Yaris 1.0 VVTi	SCP10	1.0	48	4	03.03-09.05	1SZ-FE	1,1	BKR6EY-11	4368		LPG 1
Yaris 1.0 VVTi	SCP10	1.0	50	4	04.99-09.05	1SZ-FE	1,1	BKR6EY-11	4368		LPG 1
Yaris 1.0 (KSP90) VVTi		1.0	51	3	08.05-	1KR-FE	1,1	LFR6C-11	5788	48	
Yaris 1.0 (NCP90,91) VVTi		1.0	51	3	08.05-	1KR-FE	1,1	LFR6C-11	5788	48	
Yaris 1.0 VVTi	KSP90	1.0	51	3	08.05-12.11	1KR-FE	1,1	ILFR5T11	96779		ILFR6T11
Yaris 1.0 LPG	KSP90	1.0	51	3	01.06-12.11	1KR-FE	1,1	ILFR5T11	96779		ILFR6T11
Yaris 1.0 LPG	KSP90	1.0	51	3	01.06-12.11	1KR-FE	1,1	LFR6C-11	5788	48	
Yaris 1.0 (KSP130) VVTi		1.0	51	3	09.11-	1KR-FE	1,1	ILFR5T11	96779		ILFR6T11
Yaris 1.0 VVTi	KSP130	1.0	51	3	07.14-	1KR-FE	1,1	DF6H-11B	5989		
Yaris 1.0 (SCP90, NCP90; 91 ZSP90)		1.0		3	11.05-	1KR-FE	1,1	LFR6C-11	5788	48	
Yaris Verso Van 1.3 VVTi	NCP22	1.3	62	4	04.03-09.05	2NZ-FE	1,1	BKR5EYA-11	2526	39	LPG 1
Yaris Verso Van 1.3 VVTi	NCP22	1.3	63	4	03.00-09.05	2NZ-FE	1,1	BKR5EYA-11	2526	39	LPG 1
Yaris 1.3 16V(NCP10,11,12,13)(SCP10		1.3	63	4	01.01-	2NZ-FE	1,1	BKR5EYA-11	2526	39	LPG 1
Yaris 1.3 (NCP10,11,12,13)(SCP10,12)		1.3	64	4	04.02-	2SZ-FE	0,8	BKR5EYA	2087		LPG 1





l kW C
Y
I



Stock-N°

VLINE

LPG/CNG

TOYOTA

YARIS

Yaris 1.3 (KSP90)(ZSP90) VVTi	1.3	64	4	08.05-11.06	2NZFE	1,1	BKR5EYA-11	2526	39	LPG 1
Yaris 1.3 (NCP90,91) VVTi	1.3	64	4	08.05-11.06	2NZFE	1,1	BKR5EYA-11	2526	39	LPG 1
Yaris 1.3 VVTi NSP130	1.3	73	4	10.12-	1NR-FE	1,1	ILKAR7B11	4912		
Yaris 1.3 (KSP90)(SCP90)	1.3		4	11.05-	2SZFE	0,8	BKR5EYA	2087		LPG 1
Yaris 1.3 (NCP 92, 93)	1.3		4	01.06-	2NZFE	1,1	BKR5EYA-11	2526	39	LPG 1
Yaris 1.3 (KSP130) VVTi	1.33	73	4	09.11-	1NR-FE	1,1	ILKAR7B11	4912		
Yaris 1.5 Hybrid NHP130	1.5	55	4	03.12-	1NZFXE	0,8	DIFR5C	90911		
Yaris 1.5 VVTi NCP13	1.5	77	4	01.03-09.05	1NZFE	0,8	BKR5EYA	2087		LPG 1
Yaris Verso 1.5 VVTi NCP21	1.5	77	4	04.03-09.05	1NZFE	0,8	BKR5EYA	2087		LPG 1
Yaris Verso 1.5 VVTi NCP21	1.5	78	4	03.00-09.05	1NZFE	0,8	BKR5EYA	2087		LPG 1
Yaris Verso Van 1.5 VVTi NCP21	1.5	78	4	03.00-03.03	1NZFE	0,8	BKR5EYA	2087		LPG 1
Yaris 1.5 (NCP10,11,12,13)(SCP10)	1.5	78	4	01.01-12.01	1NZFE	1,1	BKR5EYA-11	2526	39	LPG 1
Yaris 1.5 (NCP20, 21, 22)	1.5	78	4	01.02-	1NZFE	0,8	BKR5EYA	2087		LPG 1
Yaris 1.5TS (NCP10,11,12,13)(SCP10)	1.5	78	4	01.02-	1NZFE	0,8	BKR5EYA	2087		LPG 1
Yaris 1.5 (KSP90)(ZSP90)	1.5	78	4	08.05-11.06	1NZFE	0,8	BKR5EYA	2087		LPG 1
Yaris 1.5 (NCP90,91)	1.5	78	4	02.06-11.06	1NZFE	0,8	BKR5EYA	2087		LPG 1
Yaris 1.5 (NCP92, 93)	1.5		4	01.06-	1NZFE	1,1	BKR5EYA-11	2526	39	LPG 1
Yaris TS (ZSP90)	1.8	97	4	11.06-	2ZR-FE	1,1	ILKAR7B11	4912		

YARIS VERSO

Yaris Verso (NCP20,21,22)	1.3	63	4	08.99-	2NZFE	1,1	BKR5EYA-11	2526	39	LPG 1
Yaris Verso (NCP20,21,22)	1.5	78	4	.01-12.00	1NZFE	1,1	BKR5EYA-11	2526	39	LPG 1

VAZ-GM

CHEVROLET NIVA 1.7I

Chevrolet Niva 1.7i	1.7	60	4	01.02-	VAZ2121	1,1	BPR6ES-11	4824	13	LPG 2
---------------------	-----	----	---	--------	---------	-----	-----------	------	----	-------

VOLKSWAGEN

1500 / CABRIOLET

1500 / Cabriolet	1.5	32	4	08.66-	m. exhaust gas treatment	0,6	B5HS	4210		
------------------	-----	----	---	--------	--------------------------	-----	------	------	--	--

1600

1600	1.6	40	4	08.65-		0,6	B5HS	4210		
------	-----	----	---	--------	--	-----	------	------	--	--

1600 A

1600 A	1.5	33	4	08.66-		0,6	B5HS	4210		
--------	-----	----	---	--------	--	-----	------	------	--	--

1600 E

1600 E (Elek. Benzineinspritzung)	1.6	40	4	08.67-		0,6	B6HS	4510		BR7HIX
-----------------------------------	-----	----	---	--------	--	-----	------	------	--	--------

AMAROK

Amarok 2.0 TSI 2HA, 2HB	2.0	118	4	12.10-	CFPA	0,8	PFR7S8EG	1675	50	PFR8S8EG
--------------------------------	-----	-----	---	--------	------	-----	----------	------	----	----------

ARTEON

Arteon 1.5 TSi 3H7, 3H8	1.5	110	4	11.17-	DADA	0,8	ILKER7A8EGS	95929		
Arteon 1.5 TSi 3H7, 3H8, 3H9	1.5	110	4	11.17-	DPCA	0,8	ILKER7A8EGS	95929		
Arteon 2.0 TSi (For OE-No. 06K905601L) 3H7	2.0	140	4	05.17-	DKZA	0,8	ILFER7C8EG	91898		
Arteon 2.0 TSi 3H7	2.0	200	4	09.18-	DNUA	0,8	ILFER7C8EG	91898		
Arteon 2.0 TSi 3H7	2.0	206	4	04.17-	DJHC	0,8	ILFER7C8EG	91898		

BEETLE

Beetle TSi 5C7	2.0	147	4	12.10-	CCZA	0,8	PFR7S8EG	1675	50	PFR8S8EG
Beetle 2 TSi BlueMotion 5C1	2.0	162	4	12.14-	CULC	0,8	PLFER7A8EG	94833		





e kW
C
Y
I



Stock-N°

VLINE

LPG/CNG

VOLKSWAGEN

BEETLE

Beetle 2 TSI	5C1	2.5	125	5	04.11-	CBTA, CBUA, CCCA	1,1	ZFR6T-11G	5960	44	
Beetle 2.5	5C1	2.5	125	5	04.11-07.16	CBTA, CBUA, CCCA	1,1	ZFR6T-11G	5960	44	

BEETLE (9C1/1C1)

Beetle 1.4 (OE Ref 10100062AB)	9C1, 1C1	1.4	55	4	08.01-	BCA	1,1	PZFR5D-11	7968	34	LPG 6
Beetle 1.6	9C1, 1C1	1.6	74	4	11.99-10.00	AWH	1,0	BKUR6ET-10	2397	24	LPG 1
Beetle 1.6	9C1, 1C1	1.6	74	4	06.00-	AYD	1,0	BKUR6ET-10	2397	24	LPG 1
Beetle 1.6	9C1, 1C1	1.6	75	4	06.02-	BFS	1,0	BKUR6ET-10	2397	24	LPG 1
Beetle 1.8 T	9C1, 1C1	1.8	110	4	01.98-06.00	AGU	0,8	PFR6Q	6458	37	LPG 1
Beetle 1.8 T	9C1, 1C1	1.8	110	4	01.99-06.00	APH	0,8	PFR6Q	6458	37	LPG 1
Beetle 1.8 T	9C1, 1C1	1.8	110	4	07.99-10.00	AVC	0,8	PFR6Q	6458	37	LPG 1
Beetle 1.8 T	9C1, 1C1	1.8	110	4	06.00-06.04	AWV	0,8	PFR6Q	6458	37	LPG 1
Beetle 1.8 T	9C1, 1C1	1.8	110	4	10.00-	AWU	0,8	PFR6Q	6458	37	LPG 1
Beetle 1.8 T	9C1, 1C1	1.8	110	4	07.04-	BKF	0,8	PFR6Q	6458	37	LPG 1
Beetle 1.8 T	9C1, 1C1	1.8	132	4	06.02-06.04	AWP	0,8	PFR6Q	6458	37	LPG 1
Beetle 2.0	9C1, 1C1	2.0	85	4	01.98-05.01	AEG	1,0	BKUR6ET-10	2397	24	LPG 1
Beetle 2.0	9C1, 1C1	2.0	85	4	08.98-	AQY	1,0	BKUR6ET-10	2397	24	LPG 1
Beetle 2.0	9C1, 1C1	2.0	85	4	03.00-	APK	1,0	BKUR6ET-10	2397	24	LPG 1
Beetle 2.0	9C1, 1C1	2.0	85	4	06.01-	AZJ	1,1	PZFR5D-11	7968	34	LPG 6
Beetle 2.0	9C1, 1C1	2.0	85	4	06.02-07.03	AZG	1,1	PZFR5D-11	7968	34	LPG 6
Beetle 2.0	9C1, 1C1	2.0	85	4	01.03-	BER	1,1	PZFR5D-11	7968	34	LPG 6
Beetle 2.0	9C1, 1C1	2.0	85	4	07.04-	BEV	1,1	PZFR5D-11	7968	34	LPG 6
Beetle 2.0	9C1, 1C1	2.0	85	4	07.05-	BHP	1,0	BKUR6ET-10	2397	24	LPG 1
Beetle 2.0	9C1, 1C1	2.0	85	4	03.07-	CBPA	1,0	BKUR6ET-10	2397	24	LPG 1
Beetle 2.3 V5	9C1, 1C1	2.3	125	5	10.00-	AQN	1,1	PZFR5D-11	7968	34	LPG 6
Beetle 3.2 RSI	9C1, 1C1	3.2	165	6	10.00-05.01	AXJ	1,1	PZFR5D-11	7968	34	LPG 6

BEETLE 2 (5C1)

Beetle 2 1.2 TSI/ BlueMotion	5C1, 5C7	1.2	77	4	07.11-	CBZB	0,7	IZFR6P7	97153		
Beetle 2 1.2 TSI BlueMotion	5C1, 5C7	1.2	77	4	12.14-	CYVD	0,8	PZKER7B8EGS	93231	55	
Beetle 2 1.4 TSI BlueMotion	5C1, 5C7	1.4	110	4	12.14-	CZDA	0,8	PZKER7B8EGS	93231	55	
Beetle 2 1.4 TSI	5C1, 5C7	1.4	118	4	10.11-	CAVD, CNWA, CTHD, CTKA	0,8	SIZFR6B8EG	96209		
Beetle 2 2.0 TSI	5C1, 5C7	2.0	147	4	12.10-	CBFA, CCTA	0,8	PFR7S8EG	1675	50	PFR8S8EG

BORA (1J1/1J6)

Bora 1.4 16V	1J2, 1J6	1.4	55	4	09.98-05.00	AKQ	1,0	BKUR6ET-10	2397	24	LPG 1
Bora 1.4	1J2, 1J6	1.4	55	4	10.98-05.05	AHW, AXP	1,0	BKUR6ET-10	2397	24	LPG 1
Bora 1.4 (OE Ref 101000041AC / 101000033AA)	1J2, 1J6	1.4	55	4	10.98-05.05	BCA	1,0	BKUR6ET-10	2397	24	LPG 1
Bora 1.4 Automatic	1J2, 1J6	1.4	55	4	10.98-05.05	AXP	1,1	PZFR5D-11	7968	34	
Bora 1.4 (OE Ref 101000062AB)	1J2, 1J6	1.4	55	4	10.98-05.05	BCA	1,1	PZFR5D-11	7968	34	
Bora 1.4 16V	1J2, 1J6	1.4	55	4	05.99-05.00	APE	1,0	BKUR6ET-10	2397	24	LPG 1
Bora 1.6	1J2, 1J6	1.6	74	4	08.98-05.05	APF	1,0	BKUR6ET-10	2397	24	LPG 1
Bora 1.6	1J2, 1J6	1.6	74	4	09.98-06.02	AEH	1,0	BKUR6ET-10	2397	24	LPG 1
Bora 1.6	1J2, 1J6	1.6	74	4	09.98-05.03	AKL	1,0	BKUR6ET-10	2397	24	LPG 1
Bora 1.6	1J2, 1J6	1.6	74	4	09.00-04.02	AVU	1,0	BKUR6ET-10	2397	24	LPG 1
Bora 1.6 China	1J2, 1J6	1.6	74	4	10.04-	BJH	0,9	BKR6E	6962	28	LPG 1
Bora 1.6	1J2, 1J6	1.6	75	4	09.00-05.05	BFQ	1,0	BKUR6ET-10	2397	24	LPG 1





l kW
C
Y
I



Stock-N°

VLINE

LPG/CNG

VOLKSWAGEN

BORA (1J1/1J6)

Bora 1.6	1J2, 1J6	1.6	77	4	10.98-05.05	ATN, AUS	1,0	BKUR6ET-10	2397	24	LPG 1
Bora 1.6	1J2, 1J6	1.6	77	4	10.98-05.05	AZD, BCB	1,1	PZFR6J-11	3586		LPG 6
Bora 1.6 FSI	1J2, 1J6	1.6	81	4	08.01-05.05	BAD	0,5	ZFR6S-Q	6449		
Bora 1.8	1J2, 1J6	1.8	92	4	02.99-10.00	AGN	1,0	BKUR6ET-10	2397	24	LPG 1
Bora 1.8 T	1J2, 1J6	1.8	110	4	02.99-05.05	AGU, AUM	0,8	PFR6Q	6458	37	LPG 1
Bora 1.8 T	1J2, 1J6	1.8	110	4	09.00-04.01	ARX	0,8	PFR6Q	6458	37	LPG 1
Bora 1.8 T	1J2, 1J6	1.8	132	4	05.01-05.05	AUQ	0,8	PFR6Q	6458	37	LPG 1
Bora 2.0	1J2, 1J6	2.0	85	4	09.98-05.05	AQY	1,0	BKUR6ET-10	2397	24	LPG 1
Bora 2.0	1J2, 1J6	2.0	85	4	11.98-05.05	APK	1,0	BKUR6ET-10	2397	24	LPG 1
Bora 2.0	1J2, 1J6	2.0	85	4	04.00-03.05	AZH	1,0	BKUR6ET-10	2397	24	LPG 1
Bora 2.0	1J2, 1J6	2.0	85	4	05.01-05.05	AZJ	1,1	PZFR5D-11	7968	34	LPG 6
Bora 2.3 VR5	1J2, 1J6	2.3	110	5	09.98-02.01	AGZ	0,6	BKR5EKUP	2890		
Bora 2.3 VR5	1J2, 1J6	2.3	125	5	09.00-05.05	AQN	1,1	PZFR5D-11	7968	34	LPG 6
Bora 2.8 VR6 4motion	1J2, 1J6	2.8	150	6	05.99-05.00	AQP	1,1	PZFR5D-11	7968	34	LPG 6
Bora 2.8 VR6 4motion	1J2, 1J6	2.8	150	6	05.00-04.01	AUE	1,1	PZFR5D-11	7968	34	LPG 6
Bora 2.8 VR6 4motion	1J2, 1J6	2.8	150	6	05.01-05.03	BDE	1,1	PZFR5D-11	7968	34	LPG 6

BORA (1J2)

Bora	1J2	2.0	85	4	09.98-05.05	AZG	1,1	PZFR5D-11	7968	34	LPG 6
------	-----	-----	----	---	-------------	-----	-----	-----------	------	----	-------

BORA I

Bora Estate/Variant 1.4	1J6	1.4	55	4	05.00-05.05	AHW, AXP, BCA	1,0	BKUR6ET-10	2397	24	LPG 1
Bora 1.8	1J2	1.8	110	4	02.99-05.05	AGU	1,0	BKUR6ET-10	2397	24	LPG 1
Bora Estate/Variant 1.8	1J6	1.8	110	4	05.00-05.05	AGU	1,0	BKUR6ET-10	2397	24	LPG 1
Bora Estate/Variant 1.8	1J6	1.8	132	4	05.01-05.05	AUQ	0,8	PFR6Q	6458	37	LPG 1

CADDY

Caddy 4 1.4 TGI BlueMotion	SAA	1.2	62	4	06.15-	CYVC	0,8	PZKER7B8EGS	93231	55	
Caddy 4 1.4 TGI BlueMotion	SAA	1.4	92	4	05.15-	CZCB	0,8	PZKER7B8EGS	93231	55	
Caddy 3 1.6	2CB	1.6	75	4	10.10-05.15	BSF	1,0	BKUR6ET-10	2397	24	LPG 1
Caddy BiFuel	2CB	1.6	75	4	05.11-05.15	CHGA	1,0	BKUR6ET-10	2397	24	LPG 1

CADDY 1 (14)

Caddy 1 1.6	14	1.6	55	4	11.83-07.91	EW	0,7	BP6ES	7811	4	LPG 2
Caddy 1 1.8	14	1.8	70	4	08.85-07.92	JH	0,8	BUR6ET	3172	1	LPG 2

CADDY 2 (9K9A/9K9B)

Caddy 2 1.4	9K9A, 9K9B	1.4	44	4	11.95-06.03	AEX, AKV, APQ	0,8	BUR6ET	3172	1	LPG 2
Caddy 2 1.4	9K9A, 9K9B	1.4	44	4	11.95-06.03	AUD	1,1	PZFR5D-11	7968	34	LPG 6
Caddy 2 1.4	9K9A, 9K9B	1.4	55	4	09.00-06.03	AUA	1,0	BKUR6ET-10	2397	24	LPG 1
Caddy 2 1.6	9K9A, 9K9B	1.6	55	4	11.95-05.97	1F	0,8	BUR5ET	3377	22	LPG 2
Caddy 2 1.6	9K9A, 9K9B	1.6	55	4	06.96-12.00	AEE	0,8	BUR6ET	3172	1	LPG 2

CADDY 3 (2CJ)

Caddy Maxi 1.6 BiFuel	2CJ	1.6	75	4	05.11-05.15	CHGA	1,0	BKUR6ET-10	2397	24	LPG 1
-----------------------	-----	-----	----	---	-------------	------	-----	------------	------	----	-------

CADDY 3 (2KB/2KJ/2KA/2KH)

Caddy 3 1.2 TSI	2KB, 2KJ, 2KA, 2KH	1.2	63	4	09.10-05.15	CBZA	0,7	IZFR6P7	97153		
Caddy 3 1.2 TSI	2KB, 2KJ, 2KA, 2KH	1.2	77	4	09.10-05.15	CBZB	0,7	IZFR6P7	97153		
Caddy 3 1.4	2KB, 2KJ, 2KA, 2KH	1.4	55	4	02.04-05.06	BCA	1,0	BKUR6ET-10	2397	24	LPG 1
Caddy 3 1.4	2KB, 2KJ, 2KA, 2KH	1.4	59	4	05.06-08.10	BUD	1,1	ZFR6T-11G	5960	44	





l kW C
Y I



Stock-N°

VLINE

LPG/CNG

VOLKSWAGEN

CADDY 3 (2KB/2KJ/2KA/2KH)

Caddy 3 1.6 China	2KB, 2KJ, 2KA, 2KH	1,6	74	4	.05-	BRY	0,9	BKR6E	6962	28	LPG 1
Caddy 3 1.6	2KB, 2KJ, 2KA, 2KH	1,6	75	4	04.04-08.10	BGU, BSE, BSF	1,0	BKUR6ET-10	2397	24	LPG 1
Caddy 1.6 BiFuel	2CA, 2CB	1,6	75	4	05.11-05.15	CHGA	1,0	BKUR6ET-10	2397	24	LPG 1
Caddy 3 2.0 EcoFuel CNG	2KB, 2KJ, 2KA, 2KH	2,0	80	4	04.06-05.15	BSX	0,9	BKR6E	6962	28	LPG 1

CADDY 4 (SA)

Caddy 1.0 TSi BlueMotion	SAB	1,0	62	3	11.18-	DKRD	0,8	IKER7A8EGS	94224		
Caddy 1.0 TSi BlueMotion	SAA, SAB, SAH, SAJ	1,0	75	3	11.15-	CHZG, DKRE	0,8	IKER7A8EGS	94224		
Caddy 1.4 TGi Bluemotion	SAA, SAB, SAH, SAJ	1,4	81	4	05.15-	CPWA	0,8	PKER7A8DES	97861		
Caddy 1.4 TSi	SAB	1,4	96	4	07.18-	DJKD	0,8	PKER7A8EGS	95463		
Caddy Alltrack 1.4 TSi BlueMotion	SAB	1,4	96	4	07.18-	DJKD	0,8	PKER7A8EGS	95463		
Caddy Maxi 1.4 TSi BlueMotion	SAJ	1,4	96	4	07.18-	DJKD	0,8	PKER7A8EGS	95463		
Caddy 1.4 TSi BlueMotion	SAA	1,4	96	4	06.19-	DJKD	0,8	PKER7A8EGS	95463		
Caddy Alltrack 1.4 TSi BlueMotion	SAA	1,4	96	4	06.19-	DJKD	0,8	PKER7A8EGS	95463		
Caddy Maxi 1.4 TSi BlueMotion	SAH	1,4	96	4	06.19-	DJKD	0,8	PKER7A8EGS	95463		

CADDY MAXI

Caddy 3 1.6	2KJ	1,6	75	4	11.07-08.10	BSE, BSF	1,0	BKUR6ET-10	2397	24	LPG 1
-------------	-----	-----	----	---	-------------	----------	-----	------------	------	----	-------

CADDY PICK-UP

Caddy 2 1.6	9U7	1,6	55	4	06.96-12.00	AEE	0,8	BUR6ET	3172	1	LPG 2
-------------	-----	-----	----	---	-------------	-----	-----	--------	------	---	-------

CARAVELLE T5

Caravelle 2.0 EcoFuel	7HJ	2,0	85	4	01.06-03.14	AXACNG	1,0	BKUR6ET-10	2397	24	LPG 1
Caravelle 3.2	7HB, 7HJ	3,2	170	6	02.04-06.04	BDL	0,9	IZKR7B	7563		

CC

CC TSi BlueMotion	358	1,4	110	4	05.15-	CZDA	0,8	PLFER7A8EG	94833		
CC 1.4 TSi	358	1,4	118	4	11.11-	CKMA	0,6	SIZFR6A6D	91629		
CC TSi/TSi BlueMotion	358	1,4	118	4	11.11-	CTHD	0,8	SIZFR6B8EG	96209		
CC TFSI	358	1,8	112	4	11.11-	CDAB	0,8	PFR7S8EG	1675	50	
CC 1.8 TSi	358	1,8	118	4	11.11-10.12	CDA	0,8	PFR7S8EG	1675	50	PFR8S8EG
CC 2.0 TSi	358	2,0	155	4	11.11-	CCZB	0,8	PFR7S8EG	1675	50	PFR8S8EG
CC 3.6 FSI V6 4motion	358	3,6	220	6	11.11-	BWS	0,8	ILZKR8A	94290		

CC B7

CC 1.4 TSi/TSi Multifuel	358	1,4	118	4	11.11-12.16	CKMA	0,6	SIZFR6A6D	91629		
CC 1.4 TSi/TSi BlueMotion	358	1,4	118	4	11.11-12.16	CTHD	0,8	SIZFR6B8EG	96209		

CORRADO

Corrado 1.8 16V	53I	1,8	98	4	04.89-07.92	KR	0,9	BCPR7ET	2164		BCPR7EIX
Corrado 2.0	53I	2,0	85	4	04.93-09.94	2E	0,8	BUR6ET	3172	1	LPG 2
Corrado 2.0	53I	2,0	85	4	07.94-07.95	ADY	0,8	BUR6ET	3172	1	LPG 2
Corrado 2.0 16V	53I	2,0	100	4	08.91-07.95	9A	0,8	BKUR7ET	7873		
Corrado 2.8 VR6	53I	2,8	128	6	08.91-01.96	AAA	0,6	BKR5EKUP	2890		
Corrado 2.8 VR6	53I	2,8	132	6	07.95-01.96	AAA	0,6	BKR5EKUP	2890		
Corrado 2.9 VR6	53I	2,9	140	6	08.91-07.95	ABV	0,7	BKR5EKU	3964		

D 11

D 1		3,7	206	8	.01-	AYA or BDU	0,5	BKR6EKUE	7892		
-----	--	-----	-----	---	------	------------	-----	----------	------	--	--

EOS

Eos 1.4 TSi (1F7) (KW<103)	1F7	1,4	90	4	11.07-10.10	CAXA	0,9	PZFR6R	5758	52	
----------------------------	-----	-----	----	---	-------------	------	-----	--------	------	----	--





l kW C
Y
I



Stock-N°

VLINE

LPG/CNG

VOLKSWAGEN

EOS

Eos 1.4 TSI (1F8) (KW<103)	1F8	1.4	90	4	11.10-	CAXA	0,8	SIZFR6B8EG	96209		
Eos 1.4 TSI (1F7) (KW>=103)	1F7	1.4	103	4	11.07-10.10	CAXA	0,8	SIZFR6B8EG	96209		
Eos 1.4 TSI (1F8) (KW>=103)	1F8	1.4	103	4	11.10-	CAXA	0,8	SIZFR6B8EG	96209		
Eos 1.4 TSI (1F7/1F8)	1F7	1.4	118	4	04.06-07.11	CAVD	0,8	SIZFR6B8EG	96209		
Eos TSI	1F7, 1F8	1.4	118	4	05.08-	CTHD	0,9	PZFR6R	5758	52	
Eos 1.4 TSI (1F8)	1F8	1.4	118	4	11.10-	CAVD	0,8	SIZFR6B8EG	96209		
Eos 1.6 FSI (1F7)	1F7	1.6	85	4	05.06-05.08	BLF	0,5	ZFR6S-Q	6449		
Eos 2.0 FSI (1F7)	1F7	2.0	110	4	05.06-05.08	BVZ	0,9	BKR6E	6962	28	LPG 1
Eos 2.0 FSI (1F7)	1F7	2.0	110	4	05.06-05.08	BVY	1,1	PZFR5N-11T	7742		
Eos 2.0 TSI (1F7)	1F7	2.0	147	4	05.06-11.10	BWA, CAWB	0,8	PFR7S8EG	1675	50	PFR8S8EG
Eos 2.0 TSI (1F7)	1F7	2.0	147	4	11.07-11.10	CCTA	0,8	PFR7S8EG	1675	50	PFR8S8EG
Eos 2.0 TSI (1F7)	1F7	2.0	147	4	05.08-11.10	BPY	0,8	PFR7S8EG	1675	50	PFR8S8EG
Eos 2.0 TSI (1F7)	1F7	2.0	147	4	05.09-11.10	CCZA	0,8	PFR7S8EG	1675	50	PFR8S8EG
Eos 2.0 TSI (1F7)	1F7	2.0	155	4	11.09-11.10	CCZB	0,8	PFR7S8EG	1675	50	PFR8S8EG
Eos 2.0 TSI (1F8)	1F8	2.0	155	4	11.10-	CCZB	0,8	PFR7S8EG	1675	50	PFR8S8EG
Eos 3.2 V6 (1F7)	1F7	3.2	184	6	05.06-05.09	BUB, CBRA	0,9	IZKR7B	7563		
Eos 3.6 V6 (1F7)	1F7	3.6	191	6	05.09-11.10	CDVA	0,9	ILZKR7A	1961		

FOX

Fox 1.2	5Z1	1.2	40	3	04.05-12.11	BMD	0,9	ZFR5P-G	6893	41	LPG 6
Fox 1.2	5Z1	1.2	40	3	04.05-12.11	CHFB	1,1	ZFR6T-11G	5960	44	
Fox 1.2	5Z1	1.2	44	3	09.10-12.11	CHFA	1,1	ZFR6T-11G	5960	44	
Fox 1.4	5Z1	1.4	55	4	04.05-	BKR	1,1	PZFR5D-11	7968	34	LPG 6

GOLF 2

Golf 2 1.0	19E, 1G1	1.0	37	4	08.89-10.91	HZ	0,8	BUR6ET	3172	1	LPG 2
Golf 2 1.3	19E, 1G1	1.3	40	4	01.89-07.92	2G	0,8	BUR6ET	3172	1	LPG 2
Golf 2 1.3	19E, 1G1	1.3	40	4	08.89-08.91	MH	0,8	BUR6ET	3172	1	LPG 2
Golf 2 1.3	19E, 1G1	1.3	40	4	08.89-07.92	NZ	0,8	BUR6ET	3172	1	LPG 2
Golf 2 1.6	19E, 1G1	1.6	51	4	08.85-07.92	PN	1,0	BUR5ET-10	7264	21	LPG 2
Golf 2 1.6	19E, 1G1	1.6	53	4	08.86-10.91	RF	1,0	BUR5ET-10	7264	21	LPG 2
Golf 2 1.6	19E, 1G1	1.6	53	4	07.91-07.92	ABX	1,0	BP5ET-10	5156		LPG 2
Golf 2 1.6 China	19E, 1G1	1.6	53	4	- .99	ACR	0,8	BUR6ET	3172	1	LPG 2
Golf 2 1.6	19E, 1G1	1.6	55	4	08.83-07.92	EW	1,0	BUR5ET-10	7264	21	LPG 2
Golf 2 1.6	19E, 1G1	1.6	55	4	08.83-07.91	EZ	1,0	BUR5ET-10	7264	21	LPG 2
Golf 2 1.6	19E, 1G1	1.6	55	4	08.86-07.92	ABN	1,0	BUR5ET-10	7264	21	LPG 2
Golf 2 1.8	19E, 1G1	1.8	66	4	08.83-07.93	EX	0,8	BUR6ET	3172	1	LPG 2
Golf 2 1.8	19E, 1G1	1.8	66	4	08.83-10.91	GU	0,8	BUR6ET	3172	1	LPG 2
Golf 2 1.8	19E, 1G1	1.8	66	4	01.84-10.91	RP	0,8	BUR6ET	3172	1	LPG 2
Golf 2 1.8	19E, 1G1	1.8	70	4	08.83-07.93	JH	0,8	BUR6ET	3172	1	LPG 2
Golf 2 1.8 Syncro	19E, 1G1	1.8	72	4	08.88-07.91	1P	0,8	BUR6ET	3172	1	LPG 2
Golf 2 Cabriolet		1.8	72	4	08.89-07.93	2H	0,8	BUR6ET	3172	1	LPG 2
Golf 2 1.8 GTI	19E, 1G1	1.8	77	4	08.87-10.91	RV	0,8	BUR6ET	3172	1	LPG 2
Golf 2 1.8 GTI	19E, 1G1	1.8	79	4	01.87-10.91	PF	0,8	BUR6ET	3172	1	LPG 2
Golf 2 1.8 GTI	19E, 1G1	1.8	82	4	01.87-10.91	PB	0,8	BUR6ET	3172	1	LPG 2
Golf 2 1.8 GTI 16V	19E, 1G1	1.8	95	4	02.86-10.91	PL	0,8	BKUR7ET	7873		
Golf 2 1.8 GTI 16V	19E, 1G1	1.8	102	4	02.86-10.91	KR	0,9	BCPR7ET	2164		BCPR7EIX





l kW C
Y
I



Stock-N°

VLINE

LPG/CNG

VOLKSWAGEN

GOLF 2

Golf 2 (For USA)	2.0	100	4	07.89-07.92	9A	0,8	BKUR7ET	7873		
------------------	-----	-----	---	-------------	----	-----	---------	------	--	--

GOLF 3

Golf 1.4	1H1	1.4	40	4	11.91-07.95	ABD	0,8	BP5ET	2287		LPG 2
Golf Van (Hatchback) 1.4	1H1	1.4	44	4	08.91-09.97	ABD	0,8	BP5ET	2287		LPG 2
Golf Van (Hatchback) 1.4	1H1	1.4	44	4	08.91-09.97	ABD, AEX	0,8	BUR6ET	3172	1	LPG 2
Golf 3 1.4	1H1, 1H5	1.4	44	4	11.91-07.95	ABD	0,8	BUR5ET	3377	22	LPG 2
Golf 3 1.4	1H1, 1H5	1.4	44	4	11.91-12.97	AEX	0,8	BUR6ET	3172	1	LPG 2
Golf 1.4	1H1	1.4	44	4	11.91-12.97	ABD	0,8	BP5ET	2287		LPG 2
Golf 3 1.6	1H1, 1H5	1.6	55	4	08.92-09.94	ABU	0,8	BUR6ET	3172	1	LPG 2
Golf 3 1.6	1H1, 1H5	1.6	55	4	10.94-07.95	AEA	0,8	BUR6ET	3172	1	LPG 2
Golf 3 1.6	1H1, 1H5	1.6	55	4	07.95-12.97	AEE	0,8	BUR6ET	3172	1	LPG 2
Golf 3 1.6	1H1, 1H5	1.6	74	4	10.94-05.98	AEK	0,8	BKUR5ET	2789	29	LPG 1
Golf Cabrio 1.6	1E7	1.6	74	4	10.94-02.98	AFT	1,0	BKUR6ET-10	2397	24	LPG 1
Golf 3 1.6	1H1, 1H5	1.6	74	4	01.96-10.00	AFT	1,0	BKUR6ET-10	2397	24	LPG 1
Golf 3 1.6	1H1, 1H5	1.6	74	4	04.97-10.00	AKS	0,8	BKUR5ET	2789	29	LPG 1
Golf 3 1.8	1H1, 1H5	1.8	55	4	08.91-12.97	AAM	0,8	BUR5ET	3377	22	LPG 2
Golf Van (Hatchback) 1.8	1H1	1.8	55	4	08.91-07.95	AAM	0,8	BUR5ET	3377	22	LPG 2
Golf 3 1.8	1H1, 1H5	1.8	55	4	12.97-10.00	ANN	0,8	BUR5ET	3377	22	LPG 2
Golf 3 1.8	1H1, 1H5	1.8	66	4	08.91-12.97	ABS, ACC, ADZ	0,8	BUR6ET	3172	1	LPG 2
Golf Van (Hatchback) 1.8	1H1	1.8	66	4	08.91-12.97	ABS, ADZ	0,8	BUR6ET	3172	1	LPG 2
Golf 3 1.8	1H1, 1H5	1.8	66	4	12.97-10.00	ANP	0,8	BUR6ET	3172	1	LPG 2
Golf 3 1.8	1H1, 1H5	1.8	66	4	01.98-	ADD	0,8	BUR6ET	3172	1	LPG 2
Golf 3 2.0 GUS	1H1, 1H5	2.0	79	4	01.95-12.97	AEP	0,8	BUR6ET	3172	1	LPG 2
Golf 2.0	1H1	2.0	79	4	01.95-12.97	AEP	0,8	BUR6ET	3172	1	LPG 2
Golf Van (Hatchback) 2.0	1H1	2.0	85	4	08.91-09.97	2E, AGG	0,8	BUR6ET	3172	1	LPG 2
Golf 3 2.0	1H1, 1H5	2.0	85	4	11.91-08.97	2E, ADY, AGG, AKR	0,8	BUR6ET	3172	1	LPG 2
Golf 3 2.0 (For USA)	1H1, 1H5	2.0	85	4	03.92-07.95	ABA	0,8	BKR5EIX	6341		LPG 1
Golf 3 2.0 (For USA)	1H1, 1H5	2.0	85	4	02.94-07.98	ADC	0,8	BKR5EIX	6341		LPG 1
Golf Van (Hatchback) 2.0 GTi	1H1	2.0	110	4	08.91-09.97	ABF	1,0	BKUR6ET-10	2397	24	LPG 1
Golf 3 2.0 GTi 16V	1H1, 1H5	2.0	110	4	08.92-12.97	ABF	1,0	BKUR6ET-10	2397	24	LPG 1
Golf 3 Cabrio		2.3	125	5	04.00-		1,1	PZFR5D-11	7968	34	LPG 6
Golf 2.8 VR6	1H1	2.8	120	6	07.95-12.97	AAA	0,7	BKR5EKU	3964		
Golf 2.8 VR6	1H1	2.8	120	6	07.95-12.97	AAA	0,6	BKR5EKUP	2890		
Golf 3 2.8 VR6	1H1, 1H5	2.8	128	6	01.92-06.95	AAA	0,7	BKR5EKU	3964		
Golf 3 2.8 VR6	1H1, 1H5	2.8	128	6	07.95-12.97	AAA	0,6	BKR5EKUP	2890		
Golf 3 2.9 VR6 Synchro	1H1, 1H5	2.9	140	6	10.94-12.97	ABV	0,7	BKR5EKU	3964		

GOLF 4

Golf 4 1.4	1J1, 1J5	1.4	44	4	12.97-05.98	APQ	0,8	BUR6ET	3172	1	LPG 2
Golf 4 1.4	1J1, 1J5	1.4	55	4	10.97-05.00	AKQ	1,0	BKUR6ET-10	2397	24	LPG 1
Golf 4 1.4	1J1, 1J5	1.4	55	4	10.97-06.06	APE, BCA	1,0	BKUR6ET-10	2397	24	LPG 1
Golf 4 1.4 Schaltgetriebe	1J1, 1J5	1.4	55	4	05.00-10.01	AXP	1,0	BKUR6ET-10	2397	24	LPG 1
Golf 4 1.4 Automatic	1J1, 1J5	1.4	55	4	05.00-10.01	AXP	1,1	PZFR5D-11	7968	34	LPG 6
Golf Van (Variant) 1.4	1J5	1.4	55	4	05.00-12.01	AXP	1,0	BKUR6ET-10	2397	24	LPG 1
Golf Van (Variant) 1.4	1J5	1.4	55	4	05.00-06.06	BCA	1,0	BKUR6ET-10	2397	24	LPG 1
Golf Van (Variant) 1.4	1J5	1.4	55	4	01.02-06.06	AXP	1,0	BKUR6ET-10	2397	24	LPG 1





l kW C
Y
I



Stock-N°

VLINE

LPG/CNG

VOLKSWAGEN

GOLF 4

Golf 4 1.6	1J1, 1J5	1.6	74	4	10.97-05.04	AEH, AKL	1,0	BKUR6ET-10	2397	24	LPG 1
Golf 4 1.6	1J1, 1J5	1.6	74	4	05.99-08.00	APF	1,0	BKUR6ET-10	2397	24	LPG 1
Golf 4 1.6	1J1, 1J5	1.6	74	4	09.00-04.02	AVU	1,0	BKUR6ET-10	2397	24	LPG 1
Golf 4 1.6 China	1J1, 1J5	1.6	74	4	11.05-	BJH	0,9	BKR6E	6962	28	LPG 1
Golf 4 1.6	1J1, 1J5	1.6	75	4	05.02-06.06	BFQ	1,0	BKUR6ET-10	2397	24	LPG 1
Golf 4 1.6	1J1, 1J5	1.6	77	4	05.99-06.06	BCB	1,1	PZFR6J-11	3586		LPG 6
Golf 4 1.6	1J1, 1J5	1.6	77	4	11.99-05.00	ATN	1,0	BKUR6ET-10	2397	24	LPG 1
Golf 4 1.6	1J1, 1J5	1.6	77	4	05.00-10.00	AUS	1,0	BKUR6ET-10	2397	24	LPG 1
Golf Van (Variant) 1.6	1J5	1.6	77	4	05.00-06.06	AUS	1,0	BKUR6ET-10	2397	24	LPG 1
Golf 4 1.6	1J1, 1J5	1.6	77	4	09.00-11.01	AZD	1,1	PZFR6J-11	3586		LPG 6
Golf 4 1.6 China	1J1, 1J5	1.6	78	4	.04-	AWB	0,8	BKR5E	7938	35	LPG 1
Golf 4 1.6 FSI	1J1, 1J5	1.6	81	4	08.01-06.06	BAD	0,5	ZFR6S-Q	6449		
Golf 4 1.6 FSI	1J1, 1J5	1.6	85	4	10.03-07.04	BAG	0,5	ZFR6S-Q	6449		
Golf 4 1.8	1J1, 1J5	1.8	92	4	10.97-10.00	AGN	1,0	BKUR6ET-10	2397	24	LPG 1
Golf 4 1.8 China	1J1, 1J5	1.8	92	4	09.05-	BAF	1,0	BKUR6ET-10	2397	24	LPG 1
Golf 4 1.8 T	1J1, 1J5	1.8	110	4	08.97-05.06	AUM	0,8	PFR6Q	6458	37	LPG 1
Golf 4 1.8 T GTI (OE 101000051AA)	1J1, 1J5	1.8	110	4	10.97-05.03	AGU	0,8	BKUR6ET-10	2397	24	LPG 1
Golf 4 1.8 T GTI (101000063AA)	1J1, 1J5	1.8	110	4	10.97-05.03	AGU	0,8	PFR6Q	6458	37	LPG 1
Golf 4 1.8 T	1J1, 1J5	1.8	110	4	05.99-04.01	ARZ	0,8	PFR6Q	6458	37	LPG 1
Golf 4 1.8 T (For USA)	1J1, 1J5	1.8	110	4	12.99-09.00	AWD	0,8	PFR6Q	6458	37	LPG 1
Golf 4 1.8 T (For USA)	1J1, 1J5	1.8	110	4	08.00-	AWW	0,8	PFR6Q	6458	37	LPG 1
Golf 1.8 GTi	1J1	1.8	110	4	01.02-06.05	AGU	1,0	BKUR6ET-10	2397	24	LPG 1
Golf Estate/Variant 1.8	1J5	1.8	110	4	01.02-05.06	AGU	1,0	BKUR6ET-10	2397	24	LPG 1
Golf 4 1.8 T GTI	1J1, 1J5	1.8	132	4	06.01-05.04	AUQ	0,8	PFR6Q	6458	37	LPG 1
Golf 4 2.0 (For USA)	1J1, 1J5	2.0	85	4	06.98-	AEG	1,0	BKUR6ET-10	2397	24	LPG 1
Golf 4 2.0	1J1, 1J5	2.0	85	4	08.98-06.06	APK, AQY	1,0	BKUR6ET-10	2397	24	LPG 1
Golf GTi	1J5	2.0	85	4	05.99-06.06	AZJ	1,1	PZFR5D-11	7968	34	LPG 6
Golf Estate/Variant 2.0 -/GTi	1J5	2.0	85	4	05.99-06.06	AZJ	1,1	PZFR5D-11	7968	34	LPG 6
Golf 4 2.0	1J1, 1J5	2.0	85	4	06.99-06.00	ATU	0,8	PFR6Q	6458	37	LPG 1
Golf 4 2.0	1J1, 1J5	2.0	85	4	04.00-06.06	AZH	1,0	BKUR6ET-10	2397	24	LPG 1
Golf 4 2.0	1J1, 1J5	2.0	85	4	05.01-04.02	AZG	1,1	PZFR5D-11	7968	34	LPG 6
Golf 4 2.0	1J1, 1J5	2.0	85	4	05.01-06.06	AZJ	1,1	PZFR5D-11	7968	34	LPG 6
Golf 4 2.0	1J1, 1J5	2.0	85	4	05.02-06.06	BEH	1,1	PZFR5D-11	7968	34	LPG 6
Golf 2.0 BiFuel	1J1	2.0	85	4	05.02-05.03	BEH	1,1	PZFR5D-11	7968	34	LPG 6
Golf 4 2.3 V5	1J1, 1J5	2.3	110	5	10.97-02.01	AGZ	0,6	BKR5EKUP	2890		
Golf 4 2.3 V5	1J1, 1J5	2.3	125	5	09.00-05.06	AQN	1,1	PZFR5D-11	7968	34	LPG 6
Golf 4 2.8 V6 (For USA)	1J1, 1J5	2.8	130	6	03.98-05.00	AFP	0,6	BKR5EKUP	2890		
Golf 4 2.8 V6	1J1, 1J5	2.8	150	6	05.99-06.05	AQP, BDE	1,1	PZFR5D-11	7968	34	LPG 6
Golf 4 2.8 V6	1J1, 1J5	2.8	150	6	01.00-04.01	AUE	1,1	PZFR5D-11	7968	34	LPG 6
Golf 4 3.2 V6 R32	1J1, 1J5	3.2	177	6	06.02-06.05	BFH	0,9	IZKR7B	7563		
Golf 4 3.2 V6 R32	1J1, 1J5	3.2	177	6	11.03-06.06	BML	0,9	IZKR7B	7563		

GOLF 5

Golf 5 1.4	1K1, 1K5	1.4	55	4	01.05-05.06	BCA	1,0	BKUR6ET-10	2397	24	LPG 1
Golf 5 1.4	1K1, 1K5	1.4	59	4	05.06-11.08	BUD	1,1	ZFR6T-11G	5960	44	
Golf 5 1.4	1K1, 1K5	1.4	59	4	10.08-11.12	CGGA	1,1	ZFR6T-11G	5960	44	





l kW C
Y
I



Stock-N°

VLINE

LPG/CNG

VOLKSWAGEN

GOLF 5

Golf 5 1.4 FSI	1K1, 1K5	1.4	66	4	10.03-07.06	BKG	0,5	ZFR6S-Q	6449		
Golf 5 1.4 FSI	1K1, 1K5	1.4	66	4	11.04-07.06	BLN	0,5	ZFR6S-Q	6449		
Golf 5 1.4 TSI (KW<103)	1K1, 1K5	1.4	90	4	07.07-11.08	CAXA	0,8	SIZFR6B8EG	96209		
Golf 5 1.4 TSI (OE Ref 101905626)	1K1, 1K5	1.4	103	4	05.06-05.07	BMV	0,9	PZFR6R	5758	52	
Golf 5 1.4 TSI (OE Ref 03C905601A)	1K1, 1K5	1.4	103	4	05.06-05.07	BMV	0,8	SIZFR6B8EG	96209		
Golf 5 1.4 TSI (KW>=103)	1K1, 1K5	1.4	103	4	07.07-11.08	CAXA	0,8	SIZFR6B8EG	96209		
Golf 5 1.6	1K1, 1K5	1.6	75	4	01.04-06.05	BGU	1,0	BKUR6ET-10	2397	24	LPG 1
Golf 5 1.6	1K1, 1K5	1.6	75	4	05.05-11.08	BSE, BSF	1,0	BKUR6ET-10	2397	24	LPG 1
Golf 5 1.6	1K1, 1K5	1.6	75	4	11.07-12.08	CCSA	1,0	BKUR6ET-10	2397	24	LPG 1
Golf 5 1.6 FSI	1K1, 1K5	1.6	85	4	05.04-07.05	BLP	0,5	ZFR6S-Q	6449		
Golf 5 1.6 FSI	1K1, 1K5	1.6	85	4	07.04-07.08	BAG	0,5	ZFR6S-Q	6449		
Golf 5 1.6 FSI	1K1, 1K5	1.6	85	4	01.05-01.09	BLF	0,5	ZFR6S-Q	6449		
Golf 5 2.0	1K1, 1K5	2.0	85	4	09.07-	CBPA	1,0	BKUR6ET-10	2397	24	LPG 1
Golf 5 2.0 FSI	1K1, 1K5	2.0	110	4	10.03-11.08	BLY	0,9	BKR6E	6962	28	LPG 1
Golf 5 2.0 FSI	1K1, 1K5	2.0	110	4	10.03-11.08	AXW, BLR, BLX	1,1	PZFR5N-11T	7742		
Golf 5 2.0 FSI	1K1, 1K5	2.0	110	4	05.05-11.08	BVY	1,1	PZFR5N-11T	7742		
Golf 5 2.0 FSI	1K1, 1K5	2.0	110	4	11.05-11.08	BVX	1,1	PZFR5N-11T	7742		
Golf 5 2.0 FSI	1K1, 1K5	2.0	110	4	11.05-11.08	BVZ	0,9	PZFR5N-11T	7742		
Golf 5 GTI	1K1	2.0	147	4	08.04-02.09	AXX, CAWB	0,8	PFR7S8EG	1675	50	PFR8S8EG
Golf 5 GTI/TFSI	1K1	2.0	147	4	11.05-02.09	BWA	0,8	PFR7S8EG	1675	50	PFR8S8EG
Golf 5 GTI	1K1	2.0	169	4	09.06-11.08	BYD	0,8	PFR7S8EG	1675	50	PFR8S8EG
Golf 5 R32	1K1	3.2	184	6	05.05-11.08	BUB	0,9	IZKR7B	7563		

GOLF 6

Golf 6 1.2 TSI	5K1, AJ5	1.2	63	4	05.10-11.12	CBZA	0,7	IZFR6P7	97153		
Golf 6 1.2 TSI	5K1, AJ5	1.2	77	4	05.09-11.12	CBZB	0,7	IZFR6P7	97153		
Golf 6 1.4	5K1, AJ5	1.4	59	4	01.09-07.13	CGGA	1,1	ZFR6T-11G	5960	44	
Golf 6 1.4 TSI (KW<103)	5K1, AJ5	1.4	90	4	05.08-11.12	CAXA	0,8	SIZFR6B8EG	96209		
Golf 6 1.4 TSI (KW>=103)	5K1, AJ5	1.4	103	4	05.08-11.12	CAXA	0,8	SIZFR6B8EG	96209		
Golf 6 1.4 TSI	5K1, AJ5	1.4	118	4	07.08-11.12	CAVD	0,8	SIZFR6B8EG	96209		
Golf 6 1.4 TSI	5K1, AJ5	1.4	118	4	10.08-11.12	CNWA, CTHD	0,8	SIZFR6B8EG	96209		
Golf 6 1.4 TSI	5K1	1.4	118	4	10.08-11.12	CNWA	0,8	SIZFR6B8EG	96209		
Golf 6 1.6	5K1, AJ5	1.6	75	4	11.08-11.12	CCSA	1,0	BKUR6ET-10	2397	24	LPG 1
Golf 6 1.6 BiFuel (LPG)	5K1, AJ5	1.6	75	4	03.09-11.12	CHGA	1,0	BKUR6ET-10	2397	24	LPG 1
Golf 6 1.6	5K1, AJ5	1.6	75	4	05.10-11.12	CMXA	1,0	BKUR6ET-10	2397	24	LPG 1
Golf 6 1.6 Multifuel	AJ5	1.6	75	4	07.10-07.13	CMXA	1,0	BKUR6ET-10	2397	24	LPG 1
Golf 6 1.8 TSI	5K1	1.8	118	4	06.09-01.11	CDAA	0,8	PFR7S8EG	1675	50	PFR8S8EG
Golf 6 2.0 TSI		2.0	147	4	07.09-	CCZA	0,8	PFR7S8EG	1675	50	
Golf 6 TFSI	5K1	2.0	147	4	07.09-11.13	CBFA	0,8	PFR7S8EG	1675	50	PFR8S8EG
Golf 6 2.0 TFSI	5K1	2.0	147	4	07.09-11.13	CCTA	0,8	PFR7S8EG	1675	50	PFR8S8EG
Golf 6 2.0 GTI	5K1	2.0	155	4	04.09-11.12	CCZB	0,8	PFR7S8EG	1675	50	PFR8S8EG
Golf 6 2.0 GTI	5K1	2.0	173	4	05.11-11.12	CDLG	0,8	PFR7S8EG	1675	50	PFR8S8EG
Golf 6 2.0 TSI R 4motion	5K1	2.0	188	4	11.09-11.12	CDLC	0,8	PFR7S8EG	1675	50	PFR8S8EG
Golf 6 2.0 TSI R 4motion	5K1	2.0	199	4	11.09-11.12	CDLF	0,8	PFR7S8EG	1675	50	PFR8S8EG
Golf 6 2.5	5K1	2.5	125	5	07.09-05.13	CBTA, CBUA	1,1	ZFR6T-11G	5960	44	





l kW
C
Y
I



Stock-N°

VLINE

LPG/CNG

VOLKSWAGEN

GOLF 7

Golf 1.0 TSi BlueMotion (for OE number 04E905602D)	BQ1	1.0	63	3	01.17-	CHZK, DKLB	0,8	IKER7A8EGS	94224		
Golf 7 1.0 TSi BlueMotion	BQ1	1.0	81	3	11.16-	CHZC	0,8	PKER7A8EGS	95463		
Golf 7 Estate/Variant 1.0 TSi BlueMotion	BV5	1.0	81	3	11.16-	CHZC	0,8	PKER7A8EGS	95463		
Golf 7 1.0 TSi BlueMotion	5G1	1.0	85	3	05.15-	CHZD	0,8	PKER7A8EGS	95463		
Golf 7 Estate/Variant 1.0 TSi BlueMotion	BA5	1.0	85	3	05.15-	CHZD	0,8	PKER7A8EGS	95463		
Golf 7 1.2 TSi	5G1, BA5	1.2	63	4	08.12-	CJZB	0,8	PZKER7B8EGS	93231	55	
Golf 7 TSi BlueMotion	AM1	1.2	63	4	05.14-	CYVA	0,8	PZKER7B8EGS	93231	55	
Golf 7 1.2 TSi	5G1, BA5	1.2	77	4	08.12-	CJZA	0,8	PZKER7B8EGS	93231	55	
Golf 7 Cabrio TSi BlueMotion	517	1.2	77	4	11.13-	CJZA	0,8	PZKER7B8EGS	93231	55	
Golf 7 TSi BlueMotion	517	1.2	77	4	11.13-	CYVD	0,8	PZKER7B8EGS	93231	55	
Golf 7 1.2 TSi	5G1, BA5	1.2	81	4	05.14-	CYVB	0,8	PZKER7B8EGS	93231	55	
Golf 7 1.4 TSi	5G1, BA5	1.4	90	4	11.12-	CMBA, CXSA	0,8	PZKER7B8EGS	93231	55	
Golf 7 1.4 TSi Multifuel	5G1, BA5	1.4	90	4	11.12-	CPVA	0,8	PZKER7B8EGS	93231	55	
Golf 7 TSi BlueMotion	517	1.4	92	4	11.13-	CZCA	0,8	PZKER7B8EGS	93231	55	
Golf 7 1.4 TSi	5G1, BA5	1.4	92	4	05.14-	CZCA	0,8	PZKER7B8EGS	93231	55	
Golf 7 1.4 TSi Multifuel	5G1, BA5	1.4	92	4	05.14-	CPVB	0,8	PZKER7B8EGS	93231	55	
Golf 7 TSi BlueMotion	BA5	1.4	92	4	05.14-	CZDD	0,8	PZKER7B8EGS	93231	55	
Golf 7 1.4 TSi	5G1, BA5	1.4	103	4	08.12-	CHPA, CPTA	0,8	PZKER7B8EGS	93231	55	
Golf 7 1.4 TSi BlueMotion	BA5	1.4	103	4	05.13-	CHPA	0,8	PZKER7B8EGS	93231	55	
Golf 7 1.4 TSi	5G1, BA5	1.4	110	4	05.14-	CZDA	0,8	PZKER7B8EGS	93231	55	
Golf 7 1.4 TSi ACT BlueMotion/TSi BlueMotion	5G1, BA5	1.4	110	4	05.14-	CHPB	0,8	PZKER7B8EGS	93231	55	
Golf 7 1.4 TSi GTE Hybrid	5G1, BA5	1.4	110	4	05.14-	CUKB	0,8	PZKER7B8EGS	93231	55	
Golf 7 TSi BlueMotion	5G1	1.4	110	4	05.14-	CZEA	0,8	PZKER7B8EGS	93231	55	
Golf 7 1.5 TSi BlueMotion/ACT BlueMotion	AM1, AN1, BQ1, BV5	1.5	96	4	05.17-	DACA	0,8	ILKER7A8EGS	95929		
Golf 7 1.5 TSi BlueMotion	BV5	1.5	96	4	05.17-	DPBA	0,8	ILKER7A8EGS	95929		
Golf 7 1.5 TGI Bluemotion	BQ1, BV5	1.5	96	4	11.18-	DHFA	0,8	ILKER7B8DES	90560		
Golf 7 1.5 TSi BlueMotion/ACT BlueMotion	AM1, AN1, BQ1, BV5	1.5	110	4	03.17-	DADA, DPCA	0,8	ILKER7A8EGS	95929		
Golf 7 1.6 SRE	5G1	1.6	81	4	05.14-	CWVA	1,0	ZKER6A-10EG	96596		
Golf GTI	5G1	2.0	155	4	11.13-	CNTA	0,8	PLFER7A8EG	94833		
Golf 7 2.0 GTI	5G1	2.0	162	4	04.13-	CHHB	0,8	PLFER7A8EG	94833		
Golf GTI	517	2.0	162	4	11.13-	CULC	0,8	PLFER7A8EG	94833		
Golf 7 2.0 GTI Performance	5G1	2.0	169	4	04.13-	CHHA	0,8	PLFER7A8EG	94833		
Golf 7 2.0 GTI Blue Motion	BQ1	2.0	180	4	03.17-	DLBA	0,8	PLFER7A8EG	94833		
Golf 7 2.0 R 4motion	5G1	2.0	206	4	11.13-	CJXB	0,8	PLFER7A8EG	94833		
Golf 2.0 TFSi R BlueMotion	BV5	2.0	213	4	12.16-	CJXD, DJHB	0,8	ILFER7C8EG	91898		
Golf 7 2.0 R 4motion	5G1	2.0	221	4	11.13-	CJXC	0,8	PLFER7A8EG	94833		
Golf 2.0 TFSi R BlueMotion (For OE-No. 06K905601L)	BQ1, BV5	2.0	228	4	12.16-	CJXG, DJHA	0,8	ILFER7C8EG	91898		

GOLF 8

Golf 8 1.5 Tsi/ BlueMotion	CD1, CG5	1.5	96	4	07.19-	DPBA	0,8	ILKER7A8EGS	95929		
Golf 8 1.5 TGI Bluemotion	CD1	1.5	96	4	09.20-	DHFA	0,8	ILKER7B8DES	90560		
Golf 8 1.5 Mild Hybrid	CG5	1.5	96	4	12.20-	DPBA	0,8	ILKER7A8EGS	95929		
Golf 8 1.5 Tsi/ BlueMotion	CD1, CG5	1.5	110	4	07.19-	DPCA	0,8	ILKER7A8EGS	95929		
Golf 8 1.5 eTSi BlueMotion	CD1	1.5	110	4	12.19-	DFYA	0,8	ILKER7A8EGS	95929		
Golf 8 1.5 Mild Hybrid	CG5	1.5	110	4	12.20-	DPCA	0,8	ILKER7A8EGS	95929		



e kW C
Y I

Stock-N°

VLINE

LPG/CNG

VOLKSWAGEN**GOLF PLUS**

Golf Plus 1.2 TSI	521	1,2	63	4	05.10-08.14	CBZA	0,7	IZFR6P7	97153		
Golf Plus 1.2 TSI	521	1,2	77	4	11.09- .13	CBZB	0,7	IZFR6P7	97153		
Golf Plus 1.4	5M1	1,4	55	4	01.05-05.06	BCA	1,0	BKUR6ET-10	2397	24	LPG 1
Golf Plus 1.4	5M1	1,4	59	4	05.06-	BUD	1,1	ZFR6T-11G	5960	44	
Golf Plus 1.4	5M1, 521	1,4	59	4	10.08-08.14	CGGA	1,1	ZFR6T-11G	5960	44	
Golf Plus 1.4 FSI	5M1	1,4	66	4	07.05-05.06	BLN	0,5	ZFR6S-Q	6449		
Golf Plus 1.4 TSI (KW<103)	5M1, 521	1,4	90	4	07.07- .13	CAXA	0,9	PZFR6R	5758	52	
Golf Plus 1.4 TSI (OE Ref 101905626)	5M1	1,4	103	4	05.06-06.08	BMV	0,9	PZFR6R	5758	52	
Golf Plus 1.4 TSI (OE Ref 03C905601A)	5M1	1,4	103	4	05.06-06.08	BMV	0,8	SIZFR6B8EG	96209		
Golf Plus 1.4 TSI (KW>=103)	5M1, 521	1,4	103	4	07.07- .13	CAXA	0,8	SIZFR6B8EG	96209		
Golf Plus 1.4 TSI	521	1,4	118	4	05.08-08.14	CNWA	0,8	SIZFR6B8EG	96209		
Golf Plus 1.4 TSI	5M1, 521	1,4	118	4	05.08-12.08	CAVD	0,8	SIZFR6B8EG	96209		
Golf Plus 1.4 TSI	5M1	1,4	125	4	05.06-06.08	BLG	0,9	PZFR6R	5758	52	
Golf Plus 1.6	5M1, 521	1,6	75	4	05.05- .13	BSE, BSF	1,0	BKUR6ET-10	2397	24	LPG 1
Golf Plus 1.6	5M1, 521	1,6	75	4	11.07- .13	CCSA	1,0	BKUR6ET-10	2397	24	LPG 1
Golf Plus 1.6 BiFuel (LPG)	521	1,6	75	4	05.09- .13	CHGA	1,0	BKUR6ET-10	2397	24	LPG 1
Golf Plus 1.6 FSI	5M1	1,6	85	4	01.05-05.08	BLF	0,5	ZFR6S-Q	6449		
Golf Plus 2.0 FSI	5M1	2,0	110	4	05.05-07.07	BLY	0,9	BKR6E	6962	28	LPG 1
Golf Plus 2.0 FSI	5M1	2,0	110	4	05.05-06.08	BVZ	0,9	BKR6E	6962	28	LPG 1
Golf Plus 2.0 FSI	5M1	2,0	110	4	05.05-07.07	BLR	1,1	PZFR5N-11T	7742		
Golf Plus 2.0 FSI	5M1	2,0	110	4	05.05-06.08	BVY	1,1	PZFR5N-11T	7742		

GOLF SPORTSVAN

Golf Sportsvan 1.2 TSI	AM1	1,2	63	4	05.14-	CYVA	0,8	PZKER7B8EGS	93231	55	
Golf Sportsvan 1.2 TSI	AM1	1,2	81	4	04.14-	CYVB	0,8	PZKER7B8EGS	93231	55	
Golf Sportsvan 1.4 TSI	AM1	1,4	92	4	04.14-	CZCA	0,8	PZKER7B8EGS	93231	55	
Golf Sportsvan 1.4 TSI	AM1	1,4	110	4	02.14-	CZDA	0,8	PZKER7B8EGS	93231	55	

GOLF V

Golf Plus 1.4 TSi	521	1,4	90	4	01.09-08.14	CAXA	0,9	PZFR6R	5758	52	
Golf Estate/Variant 1.6 Multifuel	1K5	1,6	75	4	01.08-12.09	CCSA	1,0	BKUR6ET-10	2397	24	LPG 1
Golf Plus 1.6 BiFuel	521	1,6	75	4	05.09-08.14	CHGA	1,0	BKUR6ET-10	2397	24	LPG 1

GOLF VI

Golf 1.4 TSi	5K1	1,4	90	4	10.08-11.12	CAXA	0,9	PZFR6R	5758	52	
Golf Van (Variant) 1.4 TSi	AJ5	1,4	90	4	07.09-05.14	CAXA	0,9	PZFR6R	5758	52	
Golf 1.4 TSi	5K1	1,4	118	4	10.08-11.12	CAVD	0,8	SIZFR6B8EG	96209		
Golf Estate/Variant 1.4 TSi	AJ5	1,4	118	4	07.09-02.11	CAVD, CTKA	0,9	PZFR6R	5758	52	
Golf Van (Variant) 1.4 TSi	AJ5	1,4	118	4	07.09-02.11	CAVD	0,9	PZFR6R	5758	52	
Golf Van (Variant) 1.4 TSi	AJ5	1,4	118	4	03.11-10.12	CAVD	0,8	SIZFR6B8EG	96209		
Golf Estate/Variant 1.6 BiFuel	AJ5	1,6	75	4	07.09-12.10	BSF	1,0	BKUR6ET-10	2397	24	LPG 1
Golf Estate/Variant 1.6 Multifuel	AJ5	1,6	75	4	07.10-07.13	CMXA	1,0	BKUR6ET-10	2397	24	LPG 1
Golf 2.5	5K1	2,5	125	5	07.09-05.13	CBTA, CBUA	1,1	ZFR6T-11G	5960	44	

JETTA

Jetta 3 1.6 FSI	1K2	1,6	75	4	08.05-10.10	CCSA, CMXA	1,0	BKUR6ET-10	2397	24	LPG 1
-----------------	-----	-----	----	---	-------------	------------	-----	------------	------	----	-------

JETTA 2

Jetta 2 1.3	19E, 1G2	1,3	40	4	06.87-12.91	2G	0,8	BUR6ET	3172	1	LPG 2
Jetta 2 1.3	19E, 1G2	1,3	40	4	08.89-12.91	MH, NZ	0,8	BUR6ET	3172	1	LPG 2





l kW
C
Y
I



Stock-N°

VLINE

LPG/CNG

VOLKSWAGEN

JETTA 2

Jetta 2 1.6	19E, 1G2	1.6	51	4	10.86-10.91	PN	1,0	BUR5ET-10	7264	21	LPG 2
Jetta 2 1.6	19E, 1G2	1.6	53	4	03.86-10.91	RF	1,0	BUR5ET-10	7264	21	LPG 2
Jetta 2 1.6	19E, 1G2	1.6	55	4	01.84-07.92	ABN, EZ	1,0	BUR5ET-10	7264	21	LPG 2
Jetta 2 1.8	19E, 1G2	1.8	66	4	08.84-10.91	GU, GX	0,8	BUR6ET	3172	1	LPG 2
Jetta 2 1.8	19E, 1G2	1.8	66	4	08.87-10.91	RP	0,8	BUR6ET	3172	1	LPG 2
Jetta 2 1.8 Syncro	19E, 1G2	1.8	72	4	08.88-07.91	1P	0,8	BUR6ET	3172	1	LPG 2
Jetta 2 1.8 GT	19E, 1G2	1.8	79	4	01.87-10.91	PF	0,8	BUR6ET	3172	1	LPG 2
Jetta 2 1.8 GT	19E, 1G2	1.8	82	4	01.84-10.91	EV, PB	0,8	BUR6ET	3172	1	LPG 2
Jetta 2 1.8 GT 16V	19E, 1G2	1.8	95	4	08.86-10.91	PL	0,8	BKUR7ET	7873		

JETTA 3

Jetta 3 1.4 TSI (KW<103)	1K2	1.4	90	4	07.07-10.10	CAXA	0,9	PZFR6R	5758	52	
Jetta 3 1.4 TSI (OE Ref 101905626)	1K2	1.4	103	4	07.06-06.08	BMV	0,9	PZFR6R	5758	52	
Jetta 3 1.4 TSI (OE Ref 03C905601A)	1K2	1.4	103	4	07.06-06.08	BMV	0,8	SIZFR6B8EG	96209		
Jetta 3 1.4 TSI (KW>=103)	1K2	1.4	103	4	07.07-10.10	CAXA	0,8	SIZFR6B8EG	96209		
Jetta 3 1.4 TSI (OE 101905626)	1K2	1.4	118	4	07.08-10.10	CAVD	0,8	PZFR6R	5758	52	
Jetta 3 1.4 TSI	1K2	1.4	125	4	07.06-06.08	BLG	0,9	PZFR6R	5758	52	
Jetta 3 1.6	1K2	1.6	75	4	08.05-10.10	BSE	1,0	BKUR6ET-10	2397	24	LPG 1
Jetta 3 1.6	1K2	1.6	75	4	10.05-10.10	BSF	1,0	BKUR6ET-10	2397	24	LPG 1
Jetta 3 1.6 FSI	1K2	1.6	85	4	09.05-06.08	BLF	0,5	ZFR6S-Q	6449		
Jetta 3 2.0 FSI	1K2	2.0	110	4	08.05-06.08	BLR	1,1	PZFR5N-11T	7742		
Jetta 3 2.0 FSI	1K2	2.0	110	4	10.05-06.08	BLY	0,9	BKR6E	6962	28	LPG 1
Jetta 3 2.0 FSI	1K2	2.0	110	4	12.05-06.08	BVZ	0,9	BKR6E	6962	28	LPG 1
Jetta 3 2.0 FSI	1K2	2.0	110	4	12.05-06.08	BVY	1,1	PZFR5N-11T	7742		
Jetta 3 2.0 TFSI	1K2	2.0	147	4	09.05-10.10	BWA	0,8	PFR7S8EG	1675	50	PFR8S8EG
Jetta 3 2.0 TSI	1K2	2.0	147	4	09.05-10.10	BPY, CAWB, CBFA	0,8	PFR7S8EG	1675	50	PFR8S8EG
Jetta 3 2.5	1K2	2.5	125	5	07.07-	CCCA	1,1	ZFR6T-11G	5960	44	
Jetta	1K2	2.5	125	5	07.07-10.10	CBTA	1,1	ZFR6T-11G	5960	44	
Jetta	162, 163	2.5	125	5	04.10-	CBTA, CBUA	1,1	ZFR6T-11G	5960	44	

JETTA 4

Jetta 4 1.2 TSI	162	1.2	77	4	10.10-	CBZB	0,7	IZFR6P7	97153		
Jetta 4 1.2 TSI	163	1.2	77	4	08.14-	CYVD	0,8	PZKER7B8EGS	93231	55	
Jetta 4 1.4 TSI	162	1.4	90	4	05.11-	CMSB	0,9	PZFR6R	5758	52	
Jetta 4 1.4 TSI (KW<103)	162	1.4	90	4	05.11-	CAXA	0,9	PZFR6R	5758	52	
Jetta 4 1.4 TSI	163	1.4	92	4	08.14-	CZCA	0,8	PZKER7B8EGS	93231	55	
Jetta 4 1.4 TSI (KW>=103)	162	1.4	103	4	05.11-	CAXA	0,8	SIZFR6B8EG	96209		
Jetta 4 1.4 TSI	162	1.4	110	4	02.11-07.14	CAVA, CTHA	0,8	SIZFR6B8EG	96209		
Jetta 4 1.4 TSI Hybrid	162	1.4	110	4	07.12-	CNLA	0,8	PZKER7B8EGS	93231	55	
Jetta 4 1.4 TSI	163	1.4	110	4	08.14-	CZDA	0,8	PZKER7B8EGS	93231	55	
Jetta 4 1.4 TSI (OE 03C905601)	162	1.4	118	4	04.11-	CAVD	0,8	SIZFR6B8EG	96209		
Jetta 4 1.6	162	1.6	63	4	03.14-	CFNB	1,1	ZFR6T-11G	5960	44	
Jetta 4 1.6	162	1.6	77	4	12.11-	CFNA, CLRA	1,1	ZFR6T-11G	5960	44	
Jetta 4 2.0 TSI	162	2.0	147	4	09.05-10.10	CCTA	0,8	PFR7S8EG	1675	50	PFR8S8EG
Jetta 4 2.0 TSI	162	2.0	147	4	12.10-07.14	CCTA, CCZA	0,8	PFR7S8EG	1675	50	PFR8S8EG
Jetta 4 2.0 TSI	162	2.0	147	4	02.11-	CBFA	0,8	PFR7S8EG	1675	50	PFR8S8EG



e kW C
Y
I

Stock-N°

VLINE

LPG/CNG

VOLKSWAGEN**JETTA V**

Jetta 2.5 FSi	1K2	2.5	110	5	01.05-06.08	BGP, BTK	1,1	ZFR6T-11G	5960	44	
---------------	-----	-----	-----	---	-------------	----------	-----	-----------	------	----	--

JETTA VI

Jetta 1.6 MPI	AV2, AV3	1.6	63	4	03.14-	CFNB	1,1	ZFR6T-11G	5960	44	
Jetta 2.0	162, 163	2.0	85	4	06.10-12.17	CBPA	1,1	ZFR6T-11G	5960	44	
Jetta 2.5	162, 163	2.5	125	5	04.10-	CBTA, CBUA, CCCA	1,1	ZFR6T-11G	5960	44	

KÄFER

Käfer (MEXICO IMPORT)		1.6	34	4	01.93-	ACD	0,8	BP5ESA	2285		
-----------------------	--	-----	----	---	--------	-----	-----	--------	------	--	--

LT

LT		2.3	105	4	05.96-11.01	AGL	0,8	BKUR5ET	2789	29	LPG 1
LT		2.4	66	6	08.82-07.92	DL	0,7	BP6ESZ	7639		LPG 2
LT		2.4	70	6	08.88-12.95	1E	0,7	BP6ESZ	7639		LPG 2

LUPU

Lupo 1.0	6X1, 6E1	1.0	37	4	10.98-05.00	AHT	1,0	BKR6ETA-10	7998		
Lupo 1.0	6X1, 6E1	1.0	37	4	10.98-07.05	ALL, AER	0,8	BUR6ET	3172	1	LPG 2
Lupo 1.0	6X1, 6E1	1.0	37	4	10.98-07.05	ALD, ANV, AUC	0,9	ZFR5P-G	6893	41	LPG 6
Lupo 1.0	6X1	1.0	37	4	10.98-07.05	ALD, ANV, AUC	1,1	PZFR5D-11	7968	34	LPG 6
Lupo 1.4	6X1, 6E1	1.4	44	4	09.00-07.05	AUD	0,9	ZFR5P-G	6893	41	LPG 6
Lupo 1.4	6X1	1.4	44	4	09.00-07.05	AUD	1,1	PZFR5D-11	7968	34	LPG 6
Lupo 1.4	6X1, 6E1	1.4	55	4	10.98-07.05	AHW, AKQ, APE, AUA, BBY	1,0	BKUR6ET-10	2397	24	LPG 1
Lupo 1.4	6X1, 6E1	1.4	74	4	10.98-07.05	AUB	1,0	BKUR6ET-10	2397	24	LPG 1
Lupo 1.4	6X1, 6E1	1.4	74	4	05.99-10.00	AFK	1,0	BKUR6ET-10	2397	24	LPG 1
Lupo 1.4	6X1, 6E1	1.4	74	4	05.99-05.00	ANM, AQQ	1,0	BKUR6ET-10	2397	24	LPG 1
Lupo 1.4 FSI	6X1, 6E1	1.4	77	4	09.00-11.03	ARR	0,5	ZFR6S-Q	6449		
Lupo 1.6 GTI	6X1, 6E1	1.6	92	4	06.00-07.05	AVY	1,0	BKUR6ET-10	2397	24	LPG 1

NEW BEETLE

New Beetle 2.5 (Chassis No 1C8517070->)		2.5	110	5	03.08-09.10	BPR	1,1	ZFR6T-11G	5960	44	
New Beetle 2.5 (Chassis No 1C8517070->)	1C1, 1Y7	2.5	110	5	03.08-09.10	BPS	1,1	ZFR6T-11G	5960	44	

PASSAT 3

Passat 3 1.6	35i, 3A2, 3A5	1.6	53	4	04.88-07.91	RF	1,0	BUR5ET-10	7264	21	LPG 2
Passat 3 1.6	35i, 3A2, 3A5	1.6	55	4	08.89-07.92	ABN	1,0	BUR5ET-10	7264	21	LPG 2
Passat 3 1.6	35i, 3A2, 3A5	1.6	55	4	08.89-09.91	EZ	1,0	BUR5ET-10	7264	21	LPG 2
Passat 3 1.6	35i, 3A2, 3A5	1.6	74	4	10.94-12.95	AEK	0,8	BKUR5ET	2789	29	LPG 1
Passat 3 1.6	35i, 3A2, 3A5	1.6	74	4	12.95-12.96	AFT	1,0	BKUR6ET-10	2397	24	LPG 1
Passat 3 1.8	35i, 3A2, 3A5	1.8	55	4	08.90-12.96	AAM	0,8	BUR5ET	3377	22	LPG 2
Passat 3 1.8	35i, 3A2, 3A5	1.8	66	4	04.88-07.91	RP	0,8	BUR6ET	3172	1	LPG 2
Passat 3 1.8	35i, 3A2, 3A5	1.8	66	4	08.91-09.94	ABS	0,8	BUR6ET	3172	1	LPG 2
Passat 3 1.8	35i, 3A2, 3A5	1.8	66	4	08.94-12.96	ADZ	0,8	BUR6ET	3172	1	LPG 2
Passat 3 1.8 GUS	35i, 3A2, 3A5	1.8	85	4	01.97-04.00	AFY	1,0	BKUR6ET-10	2397	24	LPG 1
Passat 3 1.8 16V	35i, 3A2, 3A5	1.8	100	4	04.88-07.92	KR	0,9	BCPR7ET	2164		BCPR7EIX
Passat 3 2.0 China	35i, 3A2, 3A5	2.0	79	4	03.95-12.96	AEP	0,8	BUR6ET	3172	1	LPG 2
Passat 3 2.0	35i, 3A2, 3A5	2.0	85	4	03.90-09.94	2E	0,8	BUR6ET	3172	1	LPG 2
Passat 3 2.0	35i, 3A2, 3A5	2.0	85	4	06.93-12.94	ACX	0,8	BUR6ET	3172	1	LPG 2
Passat 3 2.0	35i, 3A2, 3A5	2.0	85	4	10.94-12.95	ADY	0,8	BUR6ET	3172	1	LPG 2
Passat 3 2.0	35i, 3A2, 3A5	2.0	85	4	07.96-12.96	AGG	0,8	BUR6ET	3172	1	LPG 2





l kW C
Y I



Stock-N°

VLINE

LPG/CNG

VOLKSWAGEN

PASSAT 3

Passat 3 2.0 16V	35i, 3A2, 3A5	2.0	100	4	04.88-10.93	9A	0,8	BKUR7ET	7873		
Passat 3 2.0 16V	35i, 3A2, 3A5	2.0	110	4	07.94-12.96	ABF	1,0	BKUR6ET-10	2397	24	LPG 1
Passat 3 2.8 VR6	35i, 3A2, 3A5	2.8	128	6	06.91-06.95	AAA	0,7	BKR5EKU	3964		
Passat 3 2.8 VR6	35i, 3A2, 3A5	2.8	128	6	07.95-12.96	AAA	0,6	BKR5EKUP	2890		
Passat 3 2.8 VR6 (For USA)	35i, 3A2, 3A5	2.8	142	6	10.94-12.95	AHA	0,5	BKR6EKUB	3584		LPG 1
Passat 3 2.9 VR6 Synchro	35i, 3A5	2.9	135	6	07.94-06.95	ABV	0,7	BKR5EKU	3964		
Passat 3 2.9 VR6 Synchro	35i, 3A5	2.9	135	6	07.95-12.96	ABV	0,6	BKR5EKUP	2890		

PASSAT 4

Passat 4 1.6	3B2, 3B5	1.6	74	4	10.96-08.00	ADP, AHL, ANA, ARM	1,0	BKUR6ET-10	2397	24	LPG 1
Passat 4 1.6	3B3, 3B6	1.6	75	4	10.00-05.05	ALZ	1,0	BKUR6ET-10	2397	24	LPG 1
Passat 4 1.8	3B2, 3B5	1.8	92	4	12.96-08.00	ADR, APT, ARG	1,0	BKUR6ET-10	2397	24	LPG 1
Passat 4 1.8 T	3B2, 3B5	1.8	110	4	10.96-05.05	AEB, ANB, APU	0,8	PFR6Q	6458	37	LPG 1
Passat 4 1.8 T	3B3, 3B6	1.8	110	4	10.96-05.05	AWT	0,8	PFR6Q	6458	37	LPG 1
Passat 4 1.8 T (For USA)	3B2, 3B5	1.8	110	4	08.99-05.00	ATW	0,8	PFR6Q	6458	37	LPG 1
Passat 4 1.8 T (For USA)	3B2, 3B5	1.8	110	4	05.00-08.00	AUG	0,8	PFR6Q	6458	37	LPG 1
Passat 4 1.8 T China	3B3, 3B6	1.8	110	4	12.05-	BGC	0,8	PFR6Q	6458	37	LPG 1
Passat 4 1.8 T (For USA)	3B3, 3B6	1.8	125	4	02.01-05.05	AWM	0,8	PFR6Q	6458	37	LPG 1
Passat 4 2.0	3B3, 3B6	2.0	85	4	10.00-05.05	AZM	1,0	BKUR6ET-10	2397	24	LPG 1
Passat 4 2.0	3B3, 3B6	2.0	85	4	12.05-	BFF	0,8	PFR6Q	6458	37	LPG 1
Passat 4 2.0 20V	3B3, 3B6	2.0	96	4	11.01-05.05	ALT	1,0	BKUR5ET-10	7553		LPG 1
Passat 4 2.3 V5	3B2, 3B5	2.3	110	5	10.96-08.00	AGZ	0,6	BKR5EKUP	2890		
Passat 4 2.3 V5	3B3, 3B6	2.3	125	5	01.01-05.05	AZX	1,1	PZFR5D-11	7968	34	LPG 6
Passat 4 2.8 V6 China / GUS	3B2, 3B3, 3B5, 3B6	2.8	132	6	09.97-09.99	AGE	0,5	BKR6EKUB	3584		LPG 1
Passat 4 (Typ 3B)		2.8	140	6	09.99-08.00	ATX	0,5	BKR6EKUB	3584		LPG 1
Passat 4 2.8 V6 China	3B2, 3B3, 3B5, 3B6	2.8	140	6	10.99-05.05	BBG	0,5	BKR6EKUB	3584		LPG 1
Passat 4 2.8 V6	3B2, 3B5	2.8	142	6	06.97-12.98	ACK	0,5	BKR6EKUB	3584		LPG 1
Passat 4 2.8 VR6	3B2, 3B3	2.8	142	6	06.97-05.05	ACK	0,5	BKR6EKUB	3584		LPG 1
Passat 4 2.8 VR6 Synchro	3B2, 3B5	2.8	142	6	08.97-12.98	ALG	0,5	BKR6EKUB	3584		LPG 1
Passat 4 2.8 V6	3B2, 3B5	2.8	142	6	01.99-08.00	APR	0,5	BKR6EKUB	3584		LPG 1
Passat 4 2.8 V6 4motion	3B2, 3B5	2.8	142	6	01.99-08.00	AQD	0,5	BKR6EKUB	3584		LPG 1
Passat 4 2.8 4motion	3B3, 3B6	2.8	142	6	10.00-05.05	AMX, ATQ	0,5	BKR6EKUB	3584		LPG 1
Passat 4 4.0 W8 4motion	3B3, 3B6	4.0	202	8	09.01-09.04	BDN	0,5	BKR6EKUE	7892		
Passat 4 W8		4.0	202	8	05.02-09.04	BDP	0,5	BKR6EKUE	7892		

PASSAT 5

Passat 5 1.4 TSI (Typ 3C) (KW<103)	3C2, 3C5	1.4	90	4	05.07-11.10	CAXA	0,9	PZFR6R	5758	52	
Passat 5 1.4 TSI (Typ 3C) (KW<103)	362, 365	1.4	90	4	08.10-12.14	CAXA	0,9	PZFR6R	5758	52	
Passat 5 1.4 TSI (Typ 3C) (KW>=103)	3C2, 3C5	1.4	103	4	05.07-11.10	CAXA	0,8	SIZFR6B8EG	96209		
Passat 5 1.4 TSI (Typ 3C) (KW>=103)	362, 365	1.4	103	4	08.10-12.14	CAXA	0,8	SIZFR6B8EG	96209		
Passat 5 1.4 TSI Ecofuel CNG (Typ 3C)	3C2, 3C5	1.4	110	4	01.09-	CDGA	0,6	SIZFR6A6D	91629		
Passat 5 1.4 TSI Ecofuel CNG (Typ 3C)	362, 365	1.4	110	4	09.10-12.14	CDGA	0,6	SIZFR6A6D	91629		
Passat 5 1.4 TSI Multifuel (Typ 3C)	3C2, 3C5	1.4	118	4	11.10-12.14	CKMA	0,6	SIZFR6A6D	91629		
Passat 5 1.4 TSI (Typ 3C)	3C2, 3C5	1.4	118	4	11.12-	CTHD	0,8	SIZFR6B8EG	96209		
Passat 5 1.6 (Typ 3C)	3C2, 3C5	1.6	75	4	05.05-11.10	BSE, BSF	1,0	BKUR6ET-10	2397	24	LPG 1
Passat 5 1.6 FSI (Typ 3C)	3C2, 3C5	1.6	85	4	03.05-	BLF	0,5	ZFR6S-Q	6449		





l kW C
Y
I



Stock-N°

VLINE

LPG/CNG

VOLKSWAGEN

PASSAT 5

Passat 5 1.8 TSI (Typ 3C)	3C2, 3C5	1.8	112	4	11.08-11.14	CDAB	0,8	PFR7S8EG	1675	50	PFR8S8EG
Passat 5 1.8 TSI (Typ 3C)	3C2, 3C5	1.8	112	4	11.08-12.11	CGYA	0,8	PFR7S8EG	1675	50	PFR8S8EG
Passat 5 1.8 TFSI	362	1.8	112	4	02.11-12.14	CDAB	0,8	PFR7S8EG	1675	50	PFR8S8EG
Passat 5 1.8 TSI (Typ 3C)	3C2, 3C5	1.8	118	4	05.07-12.11	CDAA	0,8	PFR7S8EG	1675	50	PFR8S8EG
Passat 5 1.8 TSI (Typ 3C)	3C2, 3C5	1.8	118	4	06.07-12.11	BZB	0,8	PFR7S8EG	1675	50	PFR8S8EG
Passat 5 2.0 FSI (Typ 3C)	3C2, 3C5	2.0	110	4	03.05-11.05	BLY	0,9	BKR6E	6962	28	LPG 1
Passat 5 2.0 FSI (Typ 3C)	3C2, 3C5	2.0	110	4	03.05-11.05	BLR	1,1	PZFR5N-11T	7742		
Passat 5 2.0 FSI (Typ 3C)	3C2, 3C5	2.0	110	4	09.05-11.05	BLX	1,1	PZFR5N-11T	7742		
Passat 5 2.0 FSI (Typ 3C)	3C2, 3C5	2.0	110	4	11.05-11.10	BVZ	0,9	BKR6E	6962	28	LPG 1
Passat 5 2.0 FSI (Typ 3C)	3C2, 3C5	2.0	110	4	11.05-11.10	BVX, BVY	1,1	PZFR5N-11T	7742		
Passat 5 2.0 TSI (Typ 3C)	3C2, 3C5	2.0	125	4	12.07-11.10	CCTA, CCTB	0,8	PFR7S8EG	1675	50	PFR8S8EG
Passat 5 2.0 TSI (Typ 3C)	3C2, 3C5	2.0	147	4	07.05-12.10	AXX	0,8	PFR7S8EG	1675	50	PFR8S8EG
Passat 5 2.0 TSI (Typ 3C)	3C2, 3C5	2.0	147	4	07.05-11.10	CCZA	0,8	PFR7S8EG	1675	50	PFR8S8EG
Passat 5 2.0 FSI/TFSi/Tsi	3C2	2.0	147	4	07.05-11.10	CBFA	0,8	PFR7S8EG	1675	50	PFR8S8EG
Passat 5 2.0 FSI (Typ 3C)	3C2, 3C5	2.0	147	4	08.05-07.10	BPY	0,8	PFR7S8EG	1675	50	PFR8S8EG
Passat 5 2.0 FSI (Typ 3C)	3C2, 3C5	2.0	147	4	11.05-12.07	BWA	0,8	PFR7S8EG	1675	50	PFR8S8EG
Passat 5 2.0 TSI (Typ 3C)	3C2, 3C5	2.0	147	4	11.05-01.10	CAWB	0,8	PFR7S8EG	1675	50	PFR8S8EG
Passat 5 2.0 TSI (Typ 3C)	3C2, 3C5	2.0	155	4	11.10-12.14	CCZB	0,8	PFR7S8EG	1675	50	PFR8S8EG
Passat 5 3.2 FSI 4motion (Typ 3C)	3C2, 3C5	3.2	184	6	09.05-05.07	AXZ	0,9	ILZKR7A	1961		
Passat 5 FSI (Typ 3C)	3C2, 3C5	3.6	206	6	09.05-	BLV	0,9	ILZKR7A	1961		
Passat 5 3.6 R36 4motion (Typ 3C)	3C2, 3C5	3.6	220	6	04.07-11.14	BWS	0,8	ILZKR8A	94290		

PASSAT 6

Passat 6 1.4 TSI	3G2, 3G5	1.4	92	4	11.14-	CZCA	0,8	PZKER7B8EGS	93231	55	
Passat 6 1.4 TSi ACT BlueMotion/TSi BlueMotion	3G2	1.4	110	4	08.14-	CZDA	0,8	PZKER7B8EGS	93231	55	
Passat 6 1.4 TSI ACT	3G2, 3G5	1.4	110	4	08.14-	CZEA	0,8	PZKER7B8EGS	93231	55	
Passat 6 1.4 TSI GTE Hybrid		1.4	115	4	.14-	CUKC	0,8	PZKER7B8EGS	93231	55	
Passat 1.4 GTE Hybrid	3G2	1.4	115	4	06.15-	CUKC	0,8	PKER7A8EGS	95463		
Passat Estate/Variant 1.4 GTE Hybrid	3G5	1.4	115	4	06.15-	CUKC	0,8	PKER7A8EGS	95463		
Passat 6 1.5 TSi	3G2, 3G5, CB2, CB5	1.5	110	4	08.18-	DADA, DPCA	0,8	ILKER7A8EGS	95929		
Passat TFSI	365	1.8	112	4	01.12-05.13	CDAB	0,8	PFR7S8EG	1675	50	PFR8S8EG
Passat 6 1.8 TFSI	362	1.8	118	4	08.10-12.14	CDAA	0,8	PFR7S8EG	1675	50	PFR8S8EG
Passat 6 1.8 TFSI	365	1.8	118	4	01.12-12.14	CDAA	0,8	PFR7S8EG	1675	50	PFR8S8EG
Passat 6 2.0 TFSI (Typ 365)	365	2.0	155	4	01.12-12.14	CCZB	0,8	PFR7S8EG	1675	50	PFR8S8EG
Passat TFSi BlueMotion	3G5	2.0	162	4	05.15-	CHHB	0,8	PLFER7A8EG	94833		
Passat 2.0 TFSi BlueMotion (For OE-No. 06K905601L)	3G2, CB2, 3G5, CB5	2.0	200	4	08.18-	DNUA	0,8	ILFER7C8EG	91898		

PASSAT B5

Passat Estate/Variant 1.8	3B6	1.8	125	4	03.01-11.05	AWM	0,8	PFR6Q	6458	37	LPG 1
Passat 2.8	3B3	2.8	140	6	10.00-05.05	BBG	0,5	BKR6EKUB	3584		LPG 1
Passat Estate/Variant 2.8	3B6	2.8	140	6	10.00-05.05	BBG	0,5	BKR6EKUB	3584		LPG 1
Passat Estate/Variant 2.8	3B6	2.8	142	6	09.00-05.05	AMX, ATQ	0,5	BKR6EKUB	3584		LPG 1

PASSAT B7

Passat Estate/Variant 1.4 TSi BlueMotion	365	1.4	90	4	08.10-12.14	CAXA	0,9	PZFR6R	5758	52	
Passat Estate/Variant 3.6 FSI	365	3.6	220	6	01.11-12.14	BWS	0,8	ILZKR8A	94290		





l kW C Y I



Stock-No

VLINE

LPG/CNG

VOLKSWAGEN

PASSAT B8

Passat 2.0 TFSi BlueMotion/TSi	CB2	2.0	140	4	11.18-	CZPB, DRFA	0,8	PLFER7A8EG	94833		
Passat Estate/Variant 2.0 TFSi BlueMotion/TSi	CB5	2.0	140	4	11.18-	CZPB, DRFA	0,8	PLFER7A8EG	94833		
Passat Alltrack 2.0 TFSi BlueMotion	CB5	2.0	206	4	11.18-	CJXA	0,8	PLFER7A8EG	94833		

PHAETON (3D2)

Phaeton 3.2 V6	3D2	3.2	177	6	05.02-05.05	AYT	0,9	IZKR7B	7563		
Phaeton 3.2 V6	3D2	3.2	177	6	08.03-11.08	BKL	0,9	IZKR7B	7563		
Phaeton 3.6 V6	3D2	3.6	206	6	11.08-05.10	CHNA	0,9	ILZKR7A	1961		
Phaeton 3.6 V6	3D2	3.6	206	6	05.10-	CMVA	0,9	ILZKR7A	1961		
Phaeton 4.2 V8	3D2	4.2	246	8	05.03-07.03	BGJ	0,5	BKR6EQUA	6872		LPG 1
Phaeton 4.2 V8	3D2	4.2	246	8	08.03-	BGH	0,5	BKR6EQUA	6872		LPG 1
Phaeton 6.0 W12	3D2	6.0	309	12	05.02-05.05	BAN	1,1	PZFR6J-11	3586		LPG 6
Phaeton 6.0 W12	3D2	6.0	309	12	10.03-	BAP	1,1	PZFR6J-11	3586		LPG 6
Phaeton 6.0 W12	3D2	6.0	331	12	05.05-10.08	BRN, BTT	1,1	PZFR6J-11	3586		LPG 6

POINTER

Pointer /Gol (RUS)		1.0		4	.05-	(8V)	1,1	PZFR5D-11	7968	34	LPG 6
--------------------	--	-----	--	---	------	------	-----	-----------	------	----	-------

POLO 2

Polo 2 1.0	86C	1.0	33	4	08.89-12.92	ACM	0,8	BUR6ET	3172	1	LPG 2
Polo 2 1.0	86C	1.0	33	4	08.89-01.92	HZ	0,8	BUR6ET	3172	1	LPG 2
Polo 2 1.0	86C	1.0	33	4	10.90-07.94	AAU	0,8	BUR5ET	3377	22	LPG 2
Polo 2 1.3	86C	1.3	40	4	01.89-07.94	2G	0,8	BUR6ET	3172	1	LPG 2
Polo 2 1.3	86C	1.3	40	4	08.89-08.91	MH	0,8	BUR6ET	3172	1	LPG 2
Polo 2 1.3	86C	1.3	40	4	08.89-12.92	NZ	0,8	BUR6ET	3172	1	LPG 2
Polo 2 1.3	86C	1.3	40	4	01.91-07.94	AAV	0,8	BUR5ET	3377	22	LPG 2
Polo 2 1.3	86C	1.3	55	4	01.90-07.94	3F	0,8	BUR6ET	3172	1	LPG 2

POLO 3

Polo 3 1.0	6N1	1.0	33	4	10.94-06.96	AEV	0,8	BUR6ET	3172	1	LPG 2
Polo Van (Hatchback) 1.0	6N1	1.0	33	4	10.94-12.99	AEV	0,8	BUR6ET	3172	1	LPG 2
Polo 3 1.0	6N1	1.0	37	4	07.96-12.99	AER	0,8	BUR6ET	3172	1	LPG 2
Polo 3 1.0	6N1	1.0	37	4	08.97-12.99	ALL	0,8	BUR6ET	3172	1	LPG 2
Polo 3 1.0	6N2	1.0	37	4	10.99-09.01	ALD, AUC	1,1	PZFR5D-11	7968	34	LPG 6
Polo 3 1.3	6N1	1.3	40	4	10.94-04.97	ADX	0,8	BUR6ET	3172	1	LPG 2
Polo 1.4	6N1, 6N2	1.4	40	4	07.95-09.01	ANX	0,8	BUR6ET	3172	1	LPG 2
Polo Classic 1.4	6V2	1.4	40	4	01.98-08.99	ANX	0,8	BUR6ET	3172	1	LPG 2
Polo 3 1.4	6N2	1.4	40	4	10.99-09.01	AKP	1,1	PZFR5D-11	7968	34	LPG 6
Polo 3 1.4	6N1	1.4	44	4	07.95-12.97	AEX	0,8	BUR6ET	3172	1	LPG 2
Polo 3 1.4	6N1	1.4	44	4	05.97-12.99	AKV	0,8	BUR6ET	3172	1	LPG 2
Polo Van (Variant) 1.4	6V5	1.4	44	4	05.97-12.99	AEX	0,8	BUR6ET	3172	1	LPG 2
Polo 3 1.4	6N1	1.4	44	4	11.97-12.99	APQ	0,8	BUR6ET	3172	1	LPG 2
Polo 3 1.4	6N2	1.4	44	4	01.98-12.99	ANX	0,8	BUR6ET	3172	1	LPG 2
Polo 3 1.4	6N2	1.4	44	4	10.99-09.01	AKK, AUD	1,1	PZFR5D-11	7968	34	LPG 6
Polo 3 1.4 Classic / Variant	6KV2, 6KV5	1.4	44	4	10.99-08.00	ANW	1,1	PZFR5D-11	7968	34	LPG 6
Polo 3 1.4 16V	6N2	1.4	55	4	10.99-09.01	AHW	1,0	BKUR6ET-10	2397	24	LPG 1
Polo 3 1.4 16V	6N2	1.4	55	4	10.99-06.00	APE	1,0	BKUR6ET-10	2397	24	LPG 1
Polo 3 1.4 16V	6N2	1.4	55	4	10.99-01.02	AUA	1,0	BKUR6ET-10	2397	24	LPG 1
Polo Van (Variant) 1.4	6V5	1.4	55	4	06.00-09.01	AUA	1,0	BKUR6ET-10	2397	24	LPG 1





l kW C
Y
I



Stock-N°

VLINE

LPG/CNG

VOLKSWAGEN

POLO 3

Polo 3 1.4 16V	6N1	1.4	74	4	04.96-12.99	AFH	1,0	BKUR6ET-10	2397	24	LPG 1
Polo 3 1.4 16V	6N2	1.4	74	4	07.99-05.00	AQQ	1,0	BKUR6ET-10	2397	24	LPG 1
Polo 3 1.4 16V	6N2	1.4	74	4	10.99-09.01	AFK	1,0	BKUR6ET-10	2397	24	LPG 1
Polo 3 1.4 16V	6N2	1.4	74	4	05.00-06.02	AUB	1,0	BKUR6ET-10	2397	24	LPG 1
Polo 3 1.6 Classic	6KV2	1.6	55	4	10.94-09.97	1F	0,8	BUR5ET	3377	22	LPG 2
Polo 3 1.6	6N1	1.6	55	4	10.94-07.95	AEA	0,8	BUR6ET	3172	1	LPG 2
Polo 3 1.6	6N1	1.6	55	4	07.95-12.99	AEE	0,8	BUR6ET	3172	1	LPG 2
Polo 3 1.6 (For Japan)	6N1	1.6	55	4	03.96-12.99	AHS	0,7	BPR5EKU	5685		LPG 2
Polo 3 1.6 Classic / Variant	6KV2, 6KV5	1.6	55	4	05.97-09.01	ALM	0,8	BUR6ET	3172	1	LPG 2
Polo Van (Variant) 1.6	6V5	1.6	55	4	09.97-12.98	AEE	0,8	BUR6ET	3172	1	LPG 2
Polo 3 1.6 Classic / Variant	6KV2, 6KV5	1.6	74	4	12.95-08.99	AFT	1,0	BKUR6ET-10	2397	24	LPG 1
Polo 3 1.6 Classic / Variant	6KV2, 6KV5	1.6	74	4	12.95-09.01	APF	1,0	BKUR6ET-10	2397	24	LPG 1
Polo 3 1.6 Classic / Variant	6KV2, 6KV5	1.6	74	4	05.96-09.01	AKL	1,0	BKUR6ET-10	2397	24	LPG 1
Polo 3 1.6 Classic / Variant	6KV2, 6KV5	1.6	74	4	10.99-09.01	AEH	1,0	BKUR6ET-10	2397	24	LPG 1
Polo 3 1.6 Classic / Variant	6KV2, 6KV5	1.6	74	4	07.00-09.01	AUR	1,0	BKUR6ET-10	2397	24	LPG 1
Polo 3 1.6 GTI	6N1	1.6	88	4	08.98-12.99	AJV	1,0	BKUR6ET-10	2397	24	LPG 1
Polo 3 1.6 GTI	6N2	1.6	92	4	11.99-09.01	ARC	1,0	BKUR6ET-10	2397	24	LPG 1
Polo 3 1.6 GTI	6N2	1.6	92	4	05.00-09.01	AVY	1,0	BKUR6ET-10	2397	24	LPG 1
Polo 3 1.8 Classic	6KV2	1.8	66	4	03.98-09.01	ADD	0,8	BUR6ET	3172	1	LPG 2
Polo 3 (Typ 6...) (Mex)		2.0	85	4	08.99-09.01	ADC	0,8	BKR5EIX	6341		LPG 1

POLO 4

Polo 4 1.2	9N	1.2	40	3	01.02-05.04	AWY	0,9	ZFR5P-G	6893	41	LPG 6
Polo 4 1.2	9N	1.2	40	3	05.04-05.07	BMD	0,9	ZFR5P-G	6893	41	LPG 6
Polo 4 1.2	9N	1.2	44	3	05.07-11.09	BBM	0,9	ZFR5P-G	6893	41	LPG 6
Polo 4 (Typ 9N)		1.2	44	3	06.09-	CGPB	1,1	ZFR6T-11G	5960	44	
Polo 4 1.2 12V	9N	1.2	47	3	11.01-05.04	AZQ	0,9	ZFR5P-G	6893	41	LPG 6
Polo 4 1.2	9N	1.2	47	3	11.04-07.07	BME	0,9	ZFR5P-G	6893	41	LPG 6
Polo 4 (Typ 9N)		1.2	51	4	06.09-	CGPA	1,1	ZFR6T-11G	5960	44	
Polo 4 1.2	9N	1.2	52	3	05.07-11.09	BZG	0,9	ZFR6T-11G	5960	44	
Polo 4 (Typ 9N)		1.2	55	3	03.10-	CJLA	1,1	ZFR6T-11G	5960	44	
Polo 4 (Typ 9N)		1.2	77	4	06.09-	CBZB	0,7	IZFR6P7	97153		
Polo 4 1.4 16V	9N	1.4	55	4	11.01-05.04	BBY	1,0	BKUR6ET-10	2397	24	LPG 1
Polo 4 1.4 16V Automatic	9N	1.4	55	4	11.01-05.04	BBY	1,1	PZFR5D-11	7968	34	LPG 6
Polo 4 1.4 16V	9N	1.4	55	4	05.04-05.08	BKY	0,9	ZFR5P-G	6893	41	LPG 6
Polo 4 1.4 16V	9N	1.4	59	4	05.06-11.09	BUD	1,1	ZFR6T-11G	5960	44	
Polo 1.4 BiFuel	9N3	1.4	60	4	05.06-11.09	BUD	1,1	ZFR6T-11G	5960	44	
Polo 4 (Typ 9N) LPG		1.4	60	4	11.09-	CMAA	1,1	ZFR6T-11G	5960	44	
Polo 4 1.4 FSI	9N	1.4	63	4	02.02-07.06	AXU	0,5	ZFR6S-Q	6449		
Polo 4 (Typ 9N)		1.4	63	4	06.09-	CGGB	1,1	ZFR6T-11G	5960	44	
Polo 4 1.4 16V	9N	1.4	74	4	05.02-05.08	BBZ	1,0	BKUR6ET-10	2397	24	LPG 1
Polo 4 (Typ 9N)		1.4	125	4	05.10-	CAVB	0,9	PZFR6R	5758	52	
Polo 4 1.6 16V	9N	1.6	77	4	05.06-11.09	BTS	1,1	ZFR6T-11G	5960	44	
Polo 4 (Typ 9N)		1.6	77	4	02.10-	CLSA	1,1	ZFR6T-11G	5960	44	
Polo 4 1.8 GTI	9N	1.8	110	4	09.05-11.09	BJX	0,8	PFR6Q	6458	37	LPG 1
Polo 4 1.8 GTI Cup Edition	9N	1.8	132	4	05.06-11.09	BBU	0,8	PFR6Q	6458	37	LPG 1





kw
C
Y
I



Stock-N°

VLINE

LPG/CNG

VOLKSWAGEN

POLO 5

Polo 5 1.0	6R	1.0	44	3	01.14-	CHYA	1,0	ZKER6A-10EG	96596		
Polo 1.0 BlueMotion	6C1	1.0	44	3	02.14-10.17	CHYA	1,0	ZKER6A-10EG	96596		
Polo 5 1.0	6R	1.0	55	3	01.14-	CHYB	1,0	ZKER6A-10EG	96596		
Polo 1.0 BlueMotion	6C1	1.0	55	3	02.14-10.17	CHYB	1,0	ZKER6A-10EG	96596		
Polo 5 1.0 TSi BlueMotion	6C1	1.0	70	3	11.14-	CHZB	0,8	PKER7A8EGS	95463		
Polo 5 1.0 BlueMotion/TSi BlueMotion	6C1	1.0	81	3	11.14-	CHZC	0,8	PKER7A8EGS	95463		
Polo 1.2	6R1	1.2	44	3	03.09-05.14	CGPB	1,1	ZFR6T-11G	5960	44	
Polo 5 1.2	6R	1.2	44	3	06.09- .14	CGPB	1,1	ZFR6T-11G	5960	44	
Polo 1.2 -/BlueMotion	6R1	1.2	51	3	03.09-05.14	CGPA	1,1	ZFR6T-11G	5960	44	
Polo 5 1.2	6R	1.2	51	3	06.09- .14	CGPA	1,1	ZFR6T-11G	5960	44	
Polo 5 1.2 TSi	6R	1.2	63	4	11.09- .14	CBZA	0,7	IZFR6P7	97153		
Polo 5 1.2 TSi	6R	1.2	66	4	05.11- .14	CBZC	0,7	IZFR6P7	97153		
Polo 5 1.2 TSi	6R	1.2	66	4	02.14-	CJZC	0,8	PZKER7B8EGS	93231	55	
Polo 5 1.2 TSi	6R	1.2	77	4	06.09- .14	CBZB	0,7	IZFR6P7	97153		
Polo 5 1.2 TSi	6R	1.2	81	4	02.14-	CJZD	0,8	PZKER7B8EGS	93231	55	
Polo 5 1.4 BiFuel	6R	1.4	60	4	03.10-01.11	CMAA	1,1	ZFR6T-11G	5960	44	
Polo 1.4 BiFuel	6R1	1.4	60	4	03.10-01.11	CMAA	1,1	ZFR6T-11G	5960	44	
Polo 1.4	6R1	1.4	63	4	03.09-05.14	CGGB	1,1	ZFR6T-11G	5960	44	
Polo 5 1.4	6R	1.4	63	4	06.09-	CGGB	1,1	ZFR6T-11G	5960	44	
Polo 5 1.4 TSi BlueGT	6R	1.4	103	4	07.12-05.14	CPTA	0,8	PZKER7B8EGS	93231	55	
Polo 5 1.4 TSi BlueGT	6R	1.4	110	4	05.14-	CZEA	0,8	PZKER7B8EGS	93231	55	
Polo 5 1.4 TSi GTI	6R	1.4	132	4	05.10- .14	CAVE	0,8	SIZFR6B8EG	96209		
Polo 5 1.4 Gti	6R1	1.4	132	4	05.10-05.14	CTHE	0,8	SIZFR6B8EG	96209		
Polo 1.4 GTi	6R1	1.4	132	4	05.10-05.14	CAVE	0,8	SIZFR6B8EG	96209		
Polo 5 1.6 RUS MPI	6R	1.6	63	4	11.10-04.12	CFNB	1,1	ZFR6T-11G	5960	44	
Polo 1.6 MPI	612	1.6	63	4	11.10-	CFNB	1,1	ZFR6T-11G	5960	44	
Polo 5 1.6	614	1.6	66	4	05.15-	CWVB	1,0	ZKER6A-10EG	96596		
Polo 5 1.6 RUS MPI	6R	1.6	77	4	05.10-	CFNA	1,1	ZFR6T-11G	5960	44	
Polo 5 1.6	614	1.6	81	4	05.15-	CWVA	1,0	ZKER6A-10EG	96596		
Polo 5 1.8 TSi GTI	6R	1.8	141	4	11.14-	DAJA, DAJB	0,8	PLFER7A8EG	94833		
Polo 5 2.0 TSi WRC	6R	2.0	162	4	08.13-05.14	CDLJ	0,8	PFR7S8EG	1675	50	

POLO 6

Polo 1.0 TGi Bluemotion	AW1	1.0	66	3	09.17-	DBYA	0,8	PKER7A8DES	97861		
Polo 1.0 TSi BlueMotion	AW1	1.0	85	3	09.17-	CHZJ, DKJA, DKRF	0,8	IKER7A8EGS	94224		

POLO 7

Polo 7 1.5 TSi	AW1	1.5	110	4	10.18-	DADA, DPCA	0,8	ILKER7A8EGS	95929		
----------------	-----	-----	-----	---	--------	------------	-----	-------------	-------	--	--

SCIROCCO

Scirocco 3 1.4 TSi	137	1.4	90	4	08.08-05.14	CMSB	0,9	PZFR6R	5758	52	
Scirocco 3 1.4 TSi	137	1.4	118	4	06.08-05.14	CNWA, CTHD, CTKA	0,8	SIZFR6B8EG	96209		
Scirocco		1.8	82	4	08.82-07.91	JJ	0,8	BUR6ET	3172	1	LPG 2
Scirocco		1.8	82	4	08.83-07.91	KT	0,8	BUR6ET	3172	1	LPG 2
Scirocco 3 2.0 TFSi BlueMotion	138	2.0	162	4	11.13-	CULC	0,8	PLFER7A8EG	94833		

SCIROCCO 2

Scirocco 2 1.6	53B	1.6	55	4	01.83-07.91	EW	1,0	BUR5ET-10	7264	21	LPG 2
Scirocco 2 1.8	53B	1.8	66	4	08.83-07.92	EX	0,8	BUR6ET	3172	1	LPG 2





e kW C
Y I



Stock-N°

VLINE

LPG/CNG

VOLKSWAGEN

SCIROCCO 2

Scirocco 2 1.8	53B	1.8	70	4	11.85-07.92	JH	0,8	BUR6ET	3172	1	LPG 2
Scirocco 2 1.8 GLI/GTI	53B	1.8	82	4	08.82-07.92	DX	0,8	BUR6ET	3172	1	LPG 2
Scirocco 2 1.8 GTI 16V	53B	1.8	95	4	02.86-07.92	PL	0,8	BKUR7ET	7873		

SCIROCCO 3 (137)

Scirocco 3 1.4 TSI (KW<103)	137	1.4	90	4	11.08-	CAXA	0,9	PZFR6R	5758	52	
Scirocco 3 1.4 TSI (KW>=103)	137	1.4	103	4	11.08-	CAXA	0,8	SIZFR6B8EG	96209		
Scirocco 3 1.4 TSI	137	1.4	118	4	08.08-10.12	CAVD	0,8	SIZFR6B8EG	96209		
Scirocco 3 2.0 TSI	137	2.0	132	4	11.13-	CULA	0,8	PLFER7A8EG	94833		
Scirocco 3 2.0 TSI	137	2.0	147	4	08.08-	CAWB	0,8	PFR7S8EG	1675	50	PFR8S8EG
Scirocco 3 2.0 TSI	137	2.0	155	4	11.09-	CCZB	0,8	PFR7S8EG	1675	50	PFR8S8EG
Scirocco 3 2.0 TSI R	137	2.0	188	4	11.09-	CDLC	0,8	PFR7S8EG	1675	50	PFR8S8EG
Scirocco 3 2.0 TSI R	137	2.0	195	4	11.09-	CDLA	0,8	PFR7S8EG	1675	50	PFR8S8EG
Scirocco 3 2.0 TSI R	137	2.0	206	4	.14-	CDLK	0,8	PFR7S8EG	1675	50	PFR8S8EG

SCIROCCO III

Scirocco 1.4 TSi	137	1.4	90	4	08.08-05.14	CAXA	0,9	PZFR6R	5758	52	
Scirocco 1.4 TSi	137	1.4	118	4	06.08-05.14	CAVD	0,8	SIZFR6B8EG	96209		

SHARAN

Sharan 3 1.4 TSi BlueMotion	7N2	1.4	110	4	05.15-	CZDA	0,8	PZKER7B8EGS	93231	55	
Sharan 1.4 TSi BlueMotion	7N2	1.4	110	4	05.15-	DJKA	0,8	PKER7A8EGS	95463		
Sharan 3 TSi BlueMotion	7N2	2.0	162	4	05.15-	DEDA	0,8	PLFER7A8EG	94833		

SHARAN 1

Sharan 1 1.8 T	7M6, 7M8, 7M9	1.8	110	4	11.97-02.00	AJH	0,8	PFR6Q	6458	37	LPG 1
Sharan 1 2.0	7M6, 7M8, 7M9	2.0	85	4	09.95-02.00	ADY	1,0	BKUR6ET-10	2397	24	LPG 1
Sharan 1 2.8 VR6	7M8	2.8	128	6	09.95-03.98	AAA	0,6	BKR5EKUP	2890		
Sharan 1 2.8 VR6	7M8	2.8	128	6	04.98-02.00	AMY	0,6	BKR5EKUP	2890		

SHARAN 2

Sharan 2 1.8 T	7M6, 7M8, 7M9	1.8	110	4	04.00-05.05	AWC	0,8	PFR6Q	6458	37	LPG 1
Sharan 2 2.0 LPG	7M6, 7M8, 7M9	2.0	85	4	04.00-03.10	ATM	1,0	BKUR6ET-10	2397	24	LPG 1
Sharan 2 2.8 V6	7M6, 7M9	2.8	150	6	04.00-03.10	AYL	1,1	PZFR5D-11	7968	34	LPG 6

SHARAN 3

Sharan 3 1.4 TSi	7N1	1.4	110	4	05.10-	CAVA	0,8	SIZFR6B8EG	96209		
Sharan 3 2.0 TSi	7N1	2.0	147	4	11.10-	CCZA	0,8	PFR7S8EG	1675	50	PFR8S8EG

T 4

T 4		2.0	62	4	09.90-06.03	AAC	0,8	BUR5ET	3377	22	LPG 2
T 4		2.5	81	5	09.90-12.93	AAF	0,8	BUR5ET	2470	22	LPG 2
T 4		2.5	81	5	08.93-10.96	ACU	0,8	BUR5ET	3377	22	LPG 2
T 4		2.5	81	5	05.95-12.95	AEN	0,8	BUR5ET	3377	22	LPG 2
T 4		2.5	81	5	08.96-09.03	AET	0,8	BUR5ET	3377	22	LPG 2
T 4 (China / GUS)		2.5	81	5	08.96-06.03	AEU	0,8	BUR5ET	3377	22	LPG 2
T 4		2.5	85	5	05.99-04.03	APL	0,8	BKUR5ET	2789	29	LPG 1
T 4		2.5	85	5	12.99-06.03	AVT	0,8	BKUR5ET	2789	29	LPG 1
T 4 VR6		2.8	103	6	01.96-05.00	AES	0,6	BKR5EKUP	2890		
T 4		2.8	150	6	05.00-09.03	AMV	1,1	PZFR5D-11	7968	34	LPG 6
T 4 VR6 (For USA)		2.8	150	6	05.00-06.03	AXK	1,1	PZFR5D-11	7968	34	LPG 6





l kW C
Y
I



Stock-N°

VLINE

LPG/CNG

VOLKSWAGEN

T 5

T 5 2.0	2.0	85	4	11.03-05.07	AXA	1,0	BKUR6ET-10	2397	24	LPG 1
T 5 2.0 TSI	2.0	110	4	07.12-08.15	CJKB	0,8	PFR7S8EG	1675	50	PFR8S8EG
T 5 2.0 TSI	2.0	110	4	04.15-	CJKB	0,8	PFR7S8EG	1675	50	PFR8S8EG
T 5 2.0 TSI	2.0	150	4	05.11-08.15	CJKA	0,8	PFR7S8EG	1675	50	PFR8S8EG
T 5 2.0 TSI	2.0	150	4	04.15-	CJKA	0,8	PFR7S8EG	1675	50	PFR8S8EG
T 5 3.2 V6	3.2	170	6	02.04-05.07	BDL	0,9	IZKR7B	7563		
T 5 3.2 V6	3.2	173	6	02.04-	BKK	0,9	IZKR7B	7563		

TARO

Taro 1.8	1.8	61	4	02.89-09.94	2Y	1,1	BPR5EY-11	3028		LPG 2
Taro 2.2	2.2	69	4	06.89-07.94	4Y	1,1	BPR5EY-11	3028		LPG 2

T-CROSS

T-Cross 1.0 TSi	C11	1.0	70	3	12.18-	CHZL, DKLA, DLAC	0,8	PKER7A8EGS	95463	
T-Cross 1.0 TSi	C11	1.0	85	3	12.18-	DKJA, DKRF	0,8	IKER7A8EGS	94224	
T-Cross 1.5 TSi	C11	1.5	110	4	11.19-	DADA, DPCA	0,8	ILKER7A8EGS	95929	

TERAMONT

Teramont 3.6 FSi	CA1	3.6	206	6	12.16-02.18	CDVC	0,9	ILZKR7A	1961	
------------------	-----	-----	-----	---	-------------	------	-----	---------	------	--

TIGUAN

Tiguan 2.0 TSi BlueMotion	5N2	1.4	92	4	05.15-	CZDB	0,8	PZKER7B8EGS	93231	55
Tiguan 1.4 TSi BlueMotion	5N2	1.4	110	4	05.15-	CZDA	0,8	PZKER7B8EGS	93231	55
Tiguan 1.5 TSi ACT	AD1	1.5	96	4	11.18-08.19	DACB	0,8	ILKER7A8EGS	95929	
Tiguan 1.5 TSi ACT	AD1	1.5	96	4	08.19-	DPBE	0,8	ILKER7A8EGS	95929	
Tiguan 1.5 TFSi/ TSi BlueMotion	AD1, BW2	1.5	110	4	09.18-	DADA	0,8	ILKER7A8EGS	95929	
Tiguan 1.5 TFSi	AD1	1.5	110	4	11.18-	DPCA	0,8	ILKER7A8EGS	95929	
Tiguan 2.0 TSi	AD1	2.0	140	4	09.18-	DKZA	0,8	ILFER7C8EG	91898	
Tiguan Allspace 2.0 TSi BlueMotion	BW2	2.0	140	4	09.18-	DNLA	0,8	ILFER7C8EG	91898	
Tiguan 2.0 TFSi	AD1	2.0	169	4	09.18-	DKTA	0,8	ILFER7C8EG	91898	

TIGUAN (5N)

Tiguan 1.4 TSi I (KW<103)	5N	1.4	90	4	08.10-	CAXA	0,8	SIZFR6B8EG	96209	
Tiguan 1.4 TSi (KW>=103)	5N	1.4	103	4	08.10-	CAXA	0,8	SIZFR6B8EG	96209	
Tiguan 1.4 TSi	5N	1.4	110	4	11.07-11.08	BWK	0,8	SIZFR6B8EG	96209	
Tiguan 1.4 TSi	5N	1.4	110	4	05.08-	CAVA	0,8	SIZFR6B8EG	96209	
Tiguan 1.4 TSi	5N	1.4	118	4	05.11-	CAVD	0,8	SIZFR6B8EG	96209	
Tiguan 2.0 TSi	5N	2.0	125	4	11.07-	CCTA	0,8	PFR7S8EG	1675	50 PFR8S8EG
Tiguan 2.0 TSi	5N	2.0	125	4	01.08-	CAWA	0,8	PFR7S8EG	1675	50 PFR8S8EG
Tiguan 2.0 TSi	5N	2.0	125	4	11.09-	CCZC	0,8	PFR7S8EG	1675	50 PFR8S8EG
Tiguan 2.0 TSi	5N	2.0	132	4	05.11-	CCZD	0,8	PFR7S8EG	1675	50 PFR8S8EG
Tiguan 2.0 TSi	5N	2.0	147	4	11.07-05.10	CAWB	0,8	PFR7S8EG	1675	50 PFR8S8EG
Tiguan 2.0 TSi	5N	2.0	147	4	11.09-	CCZA	0,8	PFR7S8EG	1675	50 PFR8S8EG
Tiguan 2.0 TSi	5N	2.0	155	4	05.11-	CCZB	0,8	PFR7S8EG	1675	50 PFR8S8EG

TOUAREG

Touareg Fsi	7P5, 7P6	3.6	183	6	08.10-	CMTA	0,9	ILZKR7A	1961	
Touareg 3.6 FSi	7P5, 7P6	3.6	183	6	08.10-03.18	CMTA	0,9	ILZKR7A	1961	
Touareg 4.2 FSi	7P5, 7P6	4.2	265	8	01.11-03.18	CGNA	0,9	PFR6W-TG	5547	
Touareg 1 6.0	7L6, 7LA	6.0	331	12	08.04-05.10	CFRA	1,1	PZFR6J-11	3586	LPG 6





l kW C
Y
I



Stock-N°

VLINE

LPG/CNG

VOLKSWAGEN

TOUAREG 1

Touareg 1 3.2	7LA, 7L6, 7L7	3.2	162	6	11.02-05.04	AZZ	0,9	IZKR7B	7563		
Touareg 1 3.2	7LA, 7L6, 7L7	3.2	162	6	05.03-05.04	BKJ	0,9	IZKR7B	7563		
Touareg 1 3.2 (For USA)	7LA, 7L6, 7L7	3.2	162	6	08.03-05.04	BAA	0,9	IZKR7B	7563		
Touareg 1 3.2	7LA, 7L6, 7L7	3.2	162	6	05.04-11.06	BMV, BMX	0,9	IZKR7B	7563		
Touareg 1 3.6 FSI	7LA, 7L6, 7L7	3.6	206	6	10.05-05.10	BHK	0,9	ILZKR7A	1961		
Touareg 1 4.2 V8	7LA, 7L6, 7L7	4.2	228	8	12.02-11.06	AXQ	0,5	BKR6EQUA	6872		LPG 1
Touareg 1 4.2 V8 FSI	7LA, 7L6, 7L7	4.2	258	8	12.06-05.10	BAR	0,9	PFR6W-TG	5547		
Touareg 1 6.0 W12	7LA, 7L6, 7L7	6.0	316	12	08.04-05.10	BJN	1,1	PZFR6J-11	3586		LPG 6

TOUAREG 2

Touareg 2 3.0 Hybrid	7P5	3.0	245	6	04.10-	CGEA, CGFA	0,8	PFR8S8EG	94460		
Touareg 2 3.6 FSI	7P5	3.6	206	6	04.10-	CGRA	0,9	ILZKR7A	1961		
Touareg 2 4.2 V8 FSI	7P5	4.2	265	8	01.11-	CGNA	0,9	PFR6W-TG	5547		

TOUAREG 4

Touareg 4 3.0 TSi	CR7	3.0	250	6	03.18-	DCBE	0,7	SILKGR9A7ES	93560		
-------------------	-----	-----	-----	---	--------	------	-----	-------------	-------	--	--

TOURAN

Touran 1 1.4 TSi	1T3	1.4	125	4	05.10-05.15	CTHB, CTHC	0,8	SIZFR6B8EG	96209		
Touran 1.6 BiFuel	1T2	1.6	75	4	11.06-05.10	BSF	1,0	BKUR6ET-10	2397	24	LPG 1
Touran 3 1.8 TSi BlueMotion	5T1	1.8	132	4	12.15-	CJSA	0,8	PLFER7A8EG	94833		

TOURAN 1

Touran 1 1.2 TSi	1T3	1.2	77	4	05.10- .15	CBZB	0,7	IZFR6P7	97153		
Touran 1 1.4 TSi (OE Ref 101905626)	1T1, 1T2	1.4	103	4	02.06-05.10	BMV	0,8	PZFR6R	5758	52	
Touran 1 1.4 TSi (OE Ref 03C905601A)	1T1, 1T2	1.4	103	4	02.06-05.10	BMV	0,8	SIZFR6B8EG	96209		
Touran 1 1.4 TSi	1T2, 1T3	1.4	103	4	11.08- .15	CAVC	0,8	SIZFR6B8EG	96209		
Touran 1 1.4 TSi Ecofuel CNG	1T2, 1T3	1.4	110	4	05.09- .15	CDGA	0,6	SIZFR6A6D	91629		
Touran 1 1.4 TSi	1T2	1.4	125	4	11.06-11.08	BLG	0,8	SIZFR6B8EG	96209		
Touran 1 1.4 TSi	1T2, 1T3	1.4	125	4	11.08- .15	CAVB	0,8	SIZFR6B8EG	96209		
Touran 1 1.6	1T1, 1T2	1.6	75	4	07.03-05.05	BGU	1,0	BKUR6ET-10	2397	24	LPG 1
Touran 1 1.6	1T1, 1T2	1.6	75	4	06.05-05.10	BSE, BSF	1,0	BKUR6ET-10	2397	24	LPG 1
Touran 1 1.6 FSI	1T1, 1T2	1.6	85	4	02.03-05.04	BAG	0,5	ZFR6S-Q	6449		
Touran 1 1.6 FSI	1T1, 1T2	1.6	85	4	05.04-05.05	BLP	0,5	ZFR6S-Q	6449		
Touran 1 1.6 FSI	1T1, 1T2	1.6	85	4	02.05-01.07	BLF	0,5	ZFR6S-Q	6449		
Touran 1 China	1T1, 1T2, 1T3	1.8	110	4	.04-	BPL	0,8	PFR6Q	6458	37	LPG 1
Touran 1 2.0 Ecofuel CNG	1T1, 1T2	2.0	80	4	02.06-05.09	BSX	0,9	BKR6E	6962	28	LPG 1
Touran 1 China	1T1, 1T2, 1T3	2.0	85	4	.04-	BJZ	0,9	ZFR5P-G	6893	41	LPG 6
Touran 1 2.0 FSI	1T1	2.0	110	4	10.03-05.04	AXW	1,1	PZFR5N-11T	7742		
Touran 1 2.0 FSI	1T1	2.0	110	4	10.03-01.04	BHD	1,1	PZFR5N-11T	7742		
Touran 1 2.0 FSI	1T1	2.0	110	4	05.04-11.05	BLY	0,9	BKR6E	6962	28	LPG 1
Touran 1 2.0 FSI	1T1	2.0	110	4	05.04-11.05	BLX	1,1	PZFR5N-11T	7742		
Touran 1 2.0 FSI	1T1	2.0	110	4	02.05-11.05	BLR	1,1	PZFR5N-11T	7742		
Touran 1 2.0 FSI	1T1	2.0	110	4	11.05-01.07	BVZ	0,9	BKR6E	6962	28	LPG 1
Touran 1 2.0 FSI	1T1	2.0	110	4	11.05-01.07	BVY	1,1	PZFR5N-11T	7742		





l kW C
Y
I



Stock-N°

VLINE

LPG/CNG

VOLKSWAGEN

TOURAN 2

Touran 1.0 TSi	5T1	1.0	85	3	07.18-	DKRB	0,8	IKER7A8EGS	94224		
Touran 2 1.2 TSi		1.2	81	4	.15-	CYVB	0,8	PZKER7B8EGS	93231	55	
Touran 2 1.4 TSi		1.4	110	4	.15-	CZDA	0,8	PZKER7B8EGS	93231	55	
Touran 2 1.5 TSi BlueMotion	5T1	1.5	110	4	11.18-	DADA, DPCA	0,8	ILKER7A8EGS	95929		
Touran 2 1.8 TSi		1.8	132	4	.15-	CJSA	0,8	PLFER7A8EG	94833		

TRANSPORTER

Transporter		1.5	32	4	08.65-		0,6	B6HS	4510		BR7HIX
Transporter		1.5	32	4	08.66-		0,6	B5HS	4210		
Transporter		1.6	35	4	08.67-	m. exhaust gas treatment	0,6	B5HS	4210		
Transporter		1.8	49	4	09.90-07.92	PD	0,8	BUR6ET	3172	1	LPG 2
Transporter 2 (MEXICO)		1.8	63	4	01.93-	ACB	0,8	BP5ES	6511	8	LPG 2
Transporter		1.9	44	4	08.89-07.92	DF	0,8	BUR6ET	3172	1	LPG 2
Transporter		1.9	57	4	08.82-07.92	DG	0,8	BUR6ET	3172	1	LPG 2
Transporter		2.1	64	4	08.86-07.92	SR	0,7	B6ES	7310		
Transporter		2.1	68	4	08.85-07.92	SS	0,7	B6ES	7310		
Transporter		2.1	70	4	08.85-07.92	MV	0,7	B6ES	7310		
Transporter		2.1	82	4	08.84-07.92	DJ	0,8	BUR6ET	3172	1	LPG 2

TRANSPORTER T4

Transporter 1.8	70A, 70E, 70L, 70M	1.8	49	4	12.90-07.92	PD	0,8	BUR6ET	3172	1	LPG 2
Transporter 2.8 VR6	7DA, 7DH, 7DE, 7DL, 7DM	2.8	103	6	01.96-05.00	AES	0,6	BKR5EKUP	2890		

TRANSPORTER T5

Transporter 2.0 EcoFuel	7EA, 7EH, 7HH	2.0	85	4	11.03-08.15	AXA	1,0	BKUR6ET-10	2397	24	LPG 1
Transporter 2.0 EcoFuel	7FE, 7JD, 7JE, 7JL	2.0	85	4	11.03-05.11	AXACNG	1,0	BKUR6ET-10	2397	24	LPG 1
Transporter 2.0 EcoFuel	7EB, 7EJ	2.0	85	4	09.09-08.15	AXACNG	1,0	BKUR6ET-10	2397	24	LPG 1
Transporter 3.2	7JD, 7JE, 7JL	3.2	170	6	11.03-11.09	BDL	0,9	IZKR7B	7563		

T-ROC

T-Roc 1.0 TSi	A11	1.0	85	3	07.17-	CHZJ	0,8	IKER7A8EGS	94224		
T-Roc 1.0 TSi	A11, AC7	1.0	85	3	07.17-	DKRF	0,8	IKER7A8EGS	94224		
T-Roc 1.5 TSi	A11	1.5	110	4	11.17-	DADA	0,8	ILKER7A8EGS	95929		
T-Roc 1.5 TSi	A11, AC7	1.5	110	4	11.17-	DPCA	0,8	ILKER7A8EGS	95929		

UP

Up 1.0	121	1.0	44	3	08.11-	CHYA	1,0	ZKER6A-10EG	96596		
Up 1.0 BlueMotion	121	1.0	44	3	08.11-	DAFA	1,0	ZKER6A-10EG	96596		
Up 1.0 Ecofuel CNG	121	1.0	50	3	11.12-	CPGA	0,8	PZKER7B8EGS	93231	55	
Up 1.0	121	1.0	55	3	08.11-	CHYB	1,0	ZKER6A-10EG	96596		
Load Up 1.0 BlueMotion	122	1.0	55	3	05.16-11.19	CHYB	1,0	ZKER6A-10EG	96596		
Load Up 1.0 TSi BlueMotion	122	1.0	66	3	05.16-09.18	CHZA	0,8	PKER7A8EGS	95463		
Up 1.0 TSi/TSi BlueMotion	122	1.0	66	3	05.16-09.19	CHZA, DKLC	0,8	PKER7A8EGS	95463		

VARIANT 1600

Variant 1600		1.6	40	4	08.65-		0,6	B5HS	4210		
--------------	--	-----	----	---	--------	--	-----	------	------	--	--

VARIANT 1600 A

Variant 1600 A		1.5	33	4	08.66-		0,6	B5HS	4210		
----------------	--	-----	----	---	--------	--	-----	------	------	--	--





l kW C
Y
I



Stock-N°

VLINE

LPG/CNG

VOLKSWAGEN

VENTO

Vento 1.4	1H2	1.4	44	4	11.91-07.95	ABD	0,8	BUR5ET	3377	22	LPG 2
Vento	1H2	1.4	44	4	01.92-12.97	APQ	0,8	BUR6ET	3172	1	LPG 2
Vento 1.4	1H2	1.4	44	4	07.95-12.97	AEX	0,8	BUR6ET	3172	1	LPG 2
Vento 1.6	1H2	1.6	55	4	08.92-09.94	ABU	0,8	BUR6ET	3172	1	LPG 2
Vento 1.6	1H2	1.6	55	4	10.94-07.95	AEA	0,8	BUR6ET	3172	1	LPG 2
Vento 1.6	1H2	1.6	55	4	07.95-12.97	AEE	0,8	BUR6ET	3172	1	LPG 2
Vento 1.6	1H2	1.6	74	4	10.94-12.95	AEK	0,8	BKUR5ET	2789	29	LPG 1
Vento 1.6	1H2	1.6	74	4	01.96-10.00	AFT	1,0	BKUR6ET-10	2397	24	LPG 1
Vento 1.8	1H2	1.8	55	4	07.91-10.00	AAM	0,8	BUR5ET	3377	22	LPG 2
Vento 1.8	1H2	1.8	66	4	11.91-07.95	ABS	0,8	BUR6ET	3172	1	LPG 2
Vento 1.8	1H2	1.8	66	4	10.94-10.00	ADZ	0,8	BUR6ET	3172	1	LPG 2
Vento 2.0	1H2	2.0	85	4	11.91-09.94	2E	0,8	BUR6ET	3172	1	LPG 2
Vento 2.0	1H2	2.0	85	4	10.94-05.96	ADY	0,8	BUR6ET	3172	1	LPG 2
Vento 2.0	1H2	2.0	85	4	07.95-12.01	AGG	0,8	BUR6ET	3172	1	LPG 2
Vento 2.0	1H2	2.0	85	4	04.97-04.00	AKR	0,8	BUR6ET	3172	1	LPG 2
Vento 2.8 VR6	1H2	2.8	128	6	01.92-06.95	AAA	0,7	BKR5EKU	3964		
Vento 1.4	1H2	1.4	40	4	01.92-07.95	ABD	0,8	BP5ET	2287		LPG 2
Vento 1.4	1H2	1.4	44	4	01.92-12.97	ABD	0,8	BP5ET	2287		LPG 2
Vento 1.6	1H2	1.6	74	4	10.94-12.97	AEK, AKS	0,8	BKUR5ET	2789	29	LPG 1
Vento 2.8 VR6	1H2	2.8	120	6	01.92-12.97	AAA	0,7	BKR5EKU	3964		
Vento 2.8 VR6	1H2	2.8	120	6	01.92-12.97	AAA	0,6	BKR5EKUP	2890		
Vento 2.8 VR6	1H2	2.8	128	6	01.92-12.97	AAA	0,7	BKR5EKU	3964		

VOLVO

122 S

122 S		1.8	59	4	.61-		0,6	BP6HS	4511	18	BPR7HIX
-------	--	-----	----	---	------	--	-----	-------	------	----	---------

240

240i		2.0	77	4	08.88-08.92		0,8	BPR6ES	7822	2	LPG 2
240i		2.0	86	4	08.87-07.92	B200E	0,8	BPR6ES	7822	2	LPG 2
240i		2.3	85	4	08.84-08.93	B230F Cat.	0,8	BPR6ES	7822	2	LPG 2
240i		2.3	96	4	08.87-07.92	B230E	0,8	BPR6ES	7822	2	LPG 2
240i		2.3		4	08.92-	B230FD	0,8	BPR6ES	7822	2	LPG 2

340

340		1.4	47	4	08.84-	B14	0,8	BPR6ES	7822	2	LPG 2
340		1.7	61	4	07.85-07.91	B172K	0,8	BPR6ES	7822	2	LPG 2

440

440i		1.6	62	4	02.92-12.95	B16F Cat.	0,7	ZGR5B	7345		
440		1.7	58	4	09.88-12.96	B18K, B Cat.	0,8	BPR6ES	7822	2	LPG 2
440		1.7	58	4	09.89-12.91	B18KD Cat.	0,7	ZGR5B	7345		
440		1.7	64	4	09.88-02.92	B18KPD Cat.	0,7	ZGR5B	7345		
440i		1.7	70	4	09.88-03.92	B18F Cat.	0,7	ZGR5B	7345		
440i		1.7	75	4	09.89-12.96	B18FP Cat.	0,7	ZGR5B	7345		
440i		1.7	88	4	09.88-07.96	B18FTM, FT Cat.	0,8	BPR7ES	2023	19	BPR8EIX
440i		1.8	66	4	09.91-07.96	B18U Cat.	0,7	ZGR5B	7345		
440i		1.8	69	4	09.91-12.95	B18 u. Cat.	0,8	BPR6ES	7822	2	LPG 2
440i		2.0	81	4	08.92-07.95	B20F Cat.	0,8	BPR7ES	2023	19	BPR8EIX





l kW C
Y
I



Stock-N°

VLINE

LPG/CNG

VOLVO

440

440i	2.0	81	4	09.92-	B20U Cat.	0,8	BPR7ES	2023	19	BPR8EIX
------	-----	----	---	--------	-----------	-----	--------	------	----	---------

460

460	1.7	64	4	01.90-09.91	B18KPD Cat.	0,7	ZGR5B	7345		
460 / 460i	1.7	66	4	03.90-12.95	B18KP, EP, Cat	0,8	BPR6ES	7822	2	LPG 2
460i	1.7	75	4	01.90-09.92	B18FP Cat.	0,7	ZGR5B	7345		
460i	1.7	88	4	01.90-12.95	B18FT Cat.	0,8	BPR7ES	2023	19	BPR8EIX
460i	1.8	66	4	09.91-12.95	B18U Cat.	0,7	ZGR5B	7345		
460i	1.8	69	4	09.91-12.95	B18 u. Cat.	0,8	BPR6ES	7822	2	LPG 2
460i	2.0	81	4	09.92-12.95	B20F Cat.	0,8	BPR7ES	2023	19	BPR8EIX

480

480i	1.7	75	4	10.89-09.92	B18FP Cat.	0,7	ZGR5B	7345		
480i	1.7	88	4	03.88-07.96	B18FT Cat.	0,8	BPR7ES	2023	19	BPR8EIX
480i	2.0	81	4	09.92-12.95	B20F Cat.	0,8	BPR7ES	2023	19	BPR8EIX

740

740i	2.0	76	4	08.83-07.91	B19E, B200E	0,8	BPR6ES	7822	2	LPG 2
740i	2.0	82	4	08.89-07.91	B200F Cat.	0,8	BPR6ES	7822	2	LPG 2
740i Turbo	2.0	105	4	08.86-07.92	B200ET, FT Cat.	0,8	BPR6ES	7822	2	LPG 2
740i	2.3	85	4	08.87-07.95	B230F Cat.	0,8	BPR6ES	7822	2	LPG 2
740i	2.3	96	4	08.84-07.92	B230E, B230F Cat.	0,8	BPR6ES	7822	2	LPG 2
740i 16V	2.3	111	4	04.88-08.92	B234F Cat.	0,8	BPR6ES	7822	2	LPG 2
740i Turbo	2.3	114	4	08.86-07.91	B230FT Cat.	0,8	BPR6ES	7822	2	LPG 2

740I

740i 16V (I)	2.0	76	4	08.88-07.91	B204E	0,8	BPR6ES	7822	2	LPG 2
--------------	-----	----	---	-------------	-------	-----	--------	------	---	-------

760

760i Turbo	2.3	114	4	08.84-07.92	B230ET, FT Cat.	0,8	BPR6ES	7822	2	LPG 2
760i	2.8	100	6	08.82-08.91	B28F, B280F Cat.	1,0	BPR6EFS	3623	7	LPG 5
760i / 780i	2.8	108	6	05.86-07.91	B280E	0,6	BP7EFS	3526		

780

780i	2.8	108	6	05.86-07.91	B280F Cat.	1,0	BPR6EFS	3623	7	LPG 5
------	-----	-----	---	-------------	------------	-----	---------	------	---	-------

800 SERIES

850 2.0	854	2.0	105	5	09.91-10.96	B5204FS	0,9	BKR6E	6962	28	LPG 1
850 Estate/Combi 2.0	855	2.0	105	5	09.93-10.97	B5204FS	0,9	BKR6E	6962	28	LPG 1
850 2.0	854	2.0	132	5	09.93-10.96	B5204T2	0,9	PFR6B	3500		LPG 1
850 Estate/Combi 2.0	855	2.0	132	5	09.93-10.97	B5204T2	0,9	PFR6B	3500		LPG 1
850 2.0	854	2.0	155	5	09.93-10.96	B5204FT	0,9	PFR6B	3500		LPG 1
850 Estate/Combi 2.0	855	2.0	155	5	09.93-10.97	B5204FT	0,9	PFR6B	3500		LPG 1
850 2.3 T5 R	854	2.3	177	5	06.95-10.96	B5234T5	0,9	PFR6B	3500		LPG 1
850 Estate/Combi 2.3 T5 R	855	2.3	177	5	06.95-10.97	B5234T5	0,9	PFR6B	3500		LPG 1
850 2.3 T5 R	854	2.3	179	5	09.94-10.97	B5234T5	0,9	PFR6B	3500		LPG 1
850 Estate/Combi 2.3 T5 R	855	2.3	179	5	06.95-10.97	B5234T5	0,9	PFR6B	3500		LPG 1
850 2.3	854	2.3	184	5	06.95-10.96	B5234T4	0,9	PFR6B	3500		LPG 1
850 Estate/Combi 2.3	855	2.3	184	5	06.95-10.97	B5234T4	0,9	PFR6B	3500		LPG 1
850 2.4	854	2.4	142	5	09.93-10.97	B5254T	0,9	PFR6B	3500		LPG 1
850 Estate/Combi 2.4	855	2.4	142	5	09.93-10.97	B5254T	0,9	PFR6B	3500		LPG 1





l kW C
Y I



Stock-N°

VLINE

LPG/CNG

VOLVO

850

850 2.0	2.0	93	5	08.94-12.96	B5202S	0,6	BKR6ETUC	3384		LPG 1
850 2.0	2.0	105	5	09.91-12.96	B5204F, B5204S	0,6	BKR6ETUC	3384		LPG 1
850 2.0 T	2.0	154	5	02.93-12.96	B5204T	0,8	BCPR6ES	2330	12	LPG 3
850 2.3 T5	2.3	166	5	04.94-12.96	B5234FT	0,6	BCPR7EIX	5690		BCPR7EIX
850 2.3 T5 R	2.3	177	5	.94-	B5234T5	0,8	BKR7EIX	2667		BKR8EIX
850 2.3 T5 R	2.3	184	5	08.95-12.96	B5234T	0,8	BKR7EIX	2667		BKR8EIX
850 2.5	2.5	103	5	06.91-07.94	B5252	0,6	BKR6ETUC	3384		LPG 1
850 2.5	2.5	106	5	08.94-12.96	B5252S	0,6	BKR6ETUC	3384		LPG 1
850 2.5	2.5	125	5	09.91-12.96	B5254F	0,6	BKR6ETUC	3384		LPG 1
850 2.5 AWD	2.5	142	5	04.96-12.96	B5254T	0,7	PFR6B	3500		LPG 1

900 SERIES

940 2.0	944	2.0	89	4	11.94-12.95	B200G	0,8	BPR6ES	7822		LPG 2
940 2.0	944	2.0	103	4	09.90-04.92	B204E	0,8	BPR6ES	7822		LPG 2
940 Estate/Combi 2.0	945	2.0	103	4	09.90-04.92	B204E	0,8	BPR6ES	7822		LPG 2
940 Estate/Combi 2.0	945	2.0	114	4	01.91-10.98	B200FT	0,8	BPR6ES	7822		LPG 2
940 2.0	944	2.0	139	4	10.94-05.97	B200GT	0,8	BPR6ES	7822		LPG 2
940 Estate/Combi 2.0	945	2.0	139	4	10.94-05.97	B200GT	0,8	BPR6ES	7822		LPG 2
960 2.0	964	2.0	140	4	09.90-08.93	B204FT	0,8	BPR6ES	7822		LPG 2
960 Estate/Combi 2.0	965	2.0	140	4	09.90-08.93	B204FT	0,8	BPR6ES	7822		LPG 2
940 2.3	944	2.3	118	4	09.90-09.93	B230FB	0,8	BPR6ES	7822		LPG 2
940 Estate/Combi 2.3	945	2.3	118	4	09.90-09.93	B230FB	0,8	BPR6ES	7822		LPG 2
960 2.3	964	2.3	121	4	09.90-08.93	B230FT	0,8	BPR6ES	7822		LPG 2
960 Estate/Combi 2.3	965	2.3	121	4	09.90-08.93	B230FT	0,8	BPR6ES	7822		LPG 2
940 2.3	944	2.3	126	4	01.95-12.98	B230FT	0,8	BPR6ES	7822		LPG 2
960 Estate/Combi 2.9	965	2.9	150	6	08.90-12.96	B6304FS, B6304GS	0,5	BKR6EQUA	6872		LPG 1
960 2.9	964	2.9	150	6	09.90-12.96	B6304FS, B6304GS	0,5	BKR6EQUA	6872		LPG 1

940

940i		2.0	82	4	09.90-07.94	B200E, B200F	0,8	BPR6ES	7822	2	LPG 2
940i Turbo		2.0	105	4	01.91-07.94	B200FT	0,8	BPR6ES	7822	2	LPG 2
940i		2.3	96	4	08.90-12.94	B230FB	0,8	BPR6ES	7822	2	LPG 2
940i		2.3	96	4	09.90-12.94	B230F	0,8	BPR6ES	7822	2	LPG 2
940		2.3	99	4	12.94-	B230GK	0,8	BPR6ES	7822	2	LPG 2
940i 16V		2.3	114	4	09.90-07.91	B234F	0,8	BPR6ES	7822	2	LPG 2
940i Turbo Intercooler		2.3	121	4	08.90-07.94	B230FT	0,8	BPR6ES	7822	2	LPG 2
940i		2.3	126	4	08.94-10.98	B230FT, FK	0,8	BPR6ES	7822	2	LPG 2

960

960i 16V Turbo Intercooler		2.0	140	4	09.90-	B204FT	0,8	BPR6ES	7822	2	LPG 2
960i Turbo Intercooler		2.3	121	4	09.90-	B230FT, FK	0,8	BPR6ES	7822	2	LPG 2
960		2.5	125	6	09.94-12.96	B6254F, G, S	0,8	BCPR6ES	2330	12	LPG 3
960i		2.8	110	6	09.90-08.91	B280F	1,0	BPR6EFS	3623	7	LPG 5
960i		2.8	125	6	09.90-	B280E	0,6	BP7EFS	3526		
960 2.9	964	2.9	150	6	09.90-07.94	B6304F	0,8	BCPR6ES	2330	12	LPG 3
960 2.9	964	2.9	150	6	07.94-12.96	B6304S	0,6	BKR6ETUC	3384		LPG 1
960		3.0	135	6	09.94-	B6304F	0,8	BCPR6ES	2330	12	LPG 3
960		3.0	150	6	09.94-	B6304F, G	0,8	BCPR6ES	2330	12	LPG 3





l kW C
Y
I



Stock-N°

VLINE

LPG/CNG

VOLVO

AMAZON

Amazon P1800 / P1800S	1.8	74	4	.68-	B18B	0,6	BP6HS	4511	18	BPR7HIX
-----------------------	-----	----	---	------	------	-----	-------	------	----	---------

C 30

C 30 1.6	1.6	74	4	11.06-	B4164S3	1,3	TR5B-13	4559	45	LPG 4
C 30 1.8	1.8	92	4	11.06-	B4184S11	1,3	TR6AP-13	5809		LPG 5
C 30 2.0	2.0	107	4	11.06-	B4204S3	1,3	TR6AP-13	5809		LPG 5
C 30 2.4	2.4	125	5	11.06-	B5244S4	0,6	LFR6D	4704		
C 30 T 5	2.5	162	5	10.06-	B5254T3	0,8	ILFR6B	6481		
C 30 T 5	2.5	169	5	03.07-	B5254T7	0,8	ILFR6B	6481		

C 70

C 70 2.0 T5	872, 873	2.0	132	5	03.98-12.98	B5204T2	0,9	PFR6B	3500		LPG 1
C 70 2.0 T5	872	2.0	166	5	06.97-12.00	B5204T3	0,9	PFR6B	3500		LPG 1
C 70 2.0 T5	873	2.0	166	5	03.98-08.00	B5204T3	0,9	PFR6B	3500		LPG 1

C 70 1

C 70		2.0	106	5	.98-	B5204S	0,8	BKR6ES	3783	28	LPG 1
C 70 2.0 T		2.0	120	5	03.00-10.05	B5204T4	0,8	PFR6B	3500		LPG 1
C 70 2.0		2.0	132	5	03.97-10.05	B5204T2	0,8	BCPR7ES	3330		BCPR7EIX
C 70 2.0 T		2.0	166	5	01.97-10.05	B5204T3	0,8	BCPR7ES	3330		BCPR7EIX
C 70 T5		2.3	176	5	03.97-10.05	B5234T	0,8	BKR7EIX	2667		BKR8EIX
C 70 2.3 T5		2.3	176	5	03.97-10.05	B5234T3	0,8	PFR6B	3500		LPG 1
C 70 2.3 T5		2.3	180	5	07.02-10.05	B5234T9	0,8	PFR6B	3500		LPG 1
C 70 2.4 T		2.4	142	5	08.99-10.05	B5244T	0,8	PFR6B	3500		LPG 1
C 70 2.4 T		2.4	147	5	07.02-10.05	B5244T7	0,8	PFR6B	3500		LPG 1
C 70		2.4	176	5	.00-	B5224T	0,8	BKR6EIX	6418		LPG 1
C 70 2.5		2.5	121	5	03.99-09.02	B5254S	0,6	BKR6ETUC	3384		LPG 1
C 70 2.5		2.5	125	5	11.99-10.05	B5244S	0,6	BKR6ETUC	3384		LPG 1
C 70 2.5 T		2.5	142	5	03.97-10.05	B5254T	0,8	PFR6B	3500		LPG 1

C 70 2

C 70 2.4		2.4	103	5	03.06-	B5244S5	0,6	LFR6D	4704		
C 70 2.4		2.4	125	5	03.06-	B5244S4	0,6	LFR6D	4704		
C 70 T5		2.5	162	5	03.06-	B5254T3	0,8	ILFR6B	6481		
C 70 T5		2.5	169	5	11.05-	B5254T7	0,8	ILFR6B	6481		

P 142 / 144 / 145

P 142 / 144 / 145		1.8	55	4	.68-	B18A	0,6	BP6HS	4511	18	BPR7HIX
P 142 / 144 / 145		1.8	74	4	.68-	B18B	0,6	BP6HS	4511	18	BPR7HIX

S 40

S 40 1.9 T4	644	1.9	147	4	10.97-12.00	B4194T, B4194T2	0,9	PFR6B	3500		LPG 1
S 40 2.0 T4	644	2.0	118	4	10.97-12.03	B4204T	0,9	PFR6B	3500		LPG 1

S 40 1

S 40 1.6		1.6	77	4	09.95-08.99	B4164S	0,6	BKR6ETUC	3384		LPG 1
S 40 1.6		1.6	80	4	03.99-12.03	B4164S2	0,6	BKR6ETUC	3384		LPG 1
S 40 1.8		1.8	85	4	07.95-08.99	B4184S	0,6	BKR6ETUC	3384		LPG 1
S 40 1.8		1.8	90	4	03.99-12.03	B4184S2	0,6	BKR6ETUC	3384		LPG 1
S 40 1.8 GDI		1.8	92	4	06.01-12.03	B4184SJ	0,6	IZFR6B	3116		
S 40		1.8		4	04.98-12.03	B4184SM, SJ	0,8	IZFR6B	3116		
S 40 T4		1.9	147	4	05.97-07.00	B4194T, T2	0,8	PFR6G	4793		PFR7G





l kW C
Y
I



Stock-N°

VLINE

LPG/CNG

VOLVO

S 40 1

S 40 2.0	2.0	100	4	07.95-12.03	B4204S, B4204S2	0,6	BKR6ETUC	3384		LPG 1
S 40 2.0	2.0	103	4	07.95-08.99	B4204S	0,6	BKR6ETUC	3384		LPG 1
S 40 2.0 T	2.0	120	4	10.97-12.03	B4204T3	0,8	PFR6B	3500		LPG 1
S 40 T4	2.0	147	4	07.00-12.03	B4204T5	0,8	PFR6B	3500		LPG 1

S 40 2

S 40 II 1.6	1.6	74	4	01.05-	B4164S3	1,3	TR5B-13	4559	45	LPG 4
S 40 II 1.8	1.8	92	4	04.04-09.10	B4184S11	1,3	TR6AP-13	5809		LPG 5
S 40 II 2.0	2.0	107	4	10.06-	B4204S3	1,3	TR6AP-13	5809		LPG 5
S 40 II 2.4	2.4	103	5	01.04-09.10	B5244S5	0,6	LFR6D	4704		
S 40 II 2.4i	2.4	125	5	01.04-09.10	B5244S4	0,6	LFR6D	4704		
S 40 II T5	2.5	162	5	01.04-05.08	B5254T3	0,8	ILFR6B	6481		
S 40 II T5	2.5	169	5	03.07-	B5254T7	0,8	ILFR6B	6481		

S 60

S 60 2.0 T4	134	2.0	132	5	12.13-12.15	B5204T8	0,8	ILFR6B	6481		
S 60 2.0 T5 DRIVe	134	2.0	180	4	09.14-12.15	B4204T7	0,8	ILTR6G8G	96621		
S 60 2.3 T5	384	2.3	195	5	07.00-12.04	B5234T7	0,9	PFR6B	3500		LPG 1
S 60 2.4	384	2.4	132	5	01.05-10.06	B5244T4	0,8	ILFR6B	6481		

S 60 1

S 60 2.0 T		2.0	132	5	09.01-07.04	B5204T5	0,8	PFR6B	3500		LPG 1
S 60 2.0 T		2.0	132	5	08.04-03.10	B5204T5	0,8	ILFR6B	6481		
S 60 2.3 T		2.3	147	5	.00-	B5234T7	0,8	PFR6B	3500		LPG 1
S 60 T5		2.3	184	5	11.00-04.10	B5234T3	0,8	PFR6B	3500		LPG 1
S 60 Bi-Fuel CNG (DK)		2.4	103	5	06.00-	B5244SG	0,6	BKR6ETUC	3384		LPG 1
S 60 2.4		2.4	103	5	11.00-	B5244S2	0,6	BKR6ETUC	3384		LPG 1
S 60 Bi-Fuel LPG		2.4	103	5	06.02-	B5244SG2	0,6	BKR6ETUC	3384		LPG 1
S 60 2.4		2.4	125	5	11.00-	B5244S	0,6	BKR6ETUC	3384		LPG 1
S 60 2.4 T		2.4	147	5	11.00-	B5244T3	0,8	PFR6B	3500		LPG 1
S 60 T5		2.4	191	5	04.04-	B5244T5	0,8	ILFR6B	6481		
S 60		2.4		5	10.00-	B5244T	0,8	PFR6B	3500		LPG 1
S 60 2.5T		2.5	154	5	02.04-04.10	B5254T2	0,8	PFR6B	3500		LPG 1
S 60 R 2.5T		2.5	220	5	03.03-	B5254T4	0,8	ILFR6B	6481		

S 60 II

S 60 II T3		1.6	110	4	04.10-	B4164T3	0,8	ILZTR6A8G	94769		
S 60 II T4		1.6	132	4	04.10-	B4164T	0,8	ILZTR6A8G	94769		
S 60 II T4F Flexfuel		1.6	132	4	04.11-	B4164T2	0,8	ILZTR6A8G	94769		
S 60 II 2.0 T		2.0	149	4	04.10-05.11	B4204T6	0,8	ILTR6G8G	96621		
S 60 II T5		2.0	176	4	04.10-	B4204T7	0,8	ILTR6G8G	96621		
S 60 II 3.0 T6	134	3.0	224	6	04.10-	B6304T4	1,1	DILFR6A11	97362		
S 60 II 3.0 T6 R	134	3.0	242	6	09.10-12.15	B6304T4	1,1	DILFR6A11	97362		
S 60 II 3.0 T6	134	3.0	258	6	05.14-	B6304T5	1,1	DILFR6A11	97362		

S 70

S 70 2.0		2.0	93	5	01.97-11.00	B5202S	0,6	BKR6ETUC	3384		LPG 1
S 70 2.0		2.0	105	5	01.97-11.00	B5204F	0,6	BKR6ETUC	3384		LPG 1
S 70 2.0		2.0	120	5	01.97-11.00	B5204T4	0,8	PFR6B	3500		LPG 1
S 70 2.0		2.0	132	5	01.97-11.00	B5204T2	0,8	BCPR7ES	3330		BCPR7EIX





l kW C
Y
I



Stock-N°

VLINE

LPG/CNG

VOLVO

S 70

S 70 2.0 T5	874	2.0	132	5	01.97-11.00	B5204T2	0,9	PFR6B	3500		LPG 1
S 70 2.0 Turbo		2.0	154	5	01.97-11.00	B5204T	0,8	BCPR7ES	3330		BCPR7EIX
S 70 2.0 T5	874	2.0	155	5	11.96-09.98	B5204T2	0,9	PFR6B	3500		LPG 1
S 70 2.0 Turbo		2.0	166	5	01.97-11.00	B5204T3	0,8	BCPR7ES	3330		BCPR7EIX
S 70 2.0 T5	874	2.0	166	5	11.96-09.00	B5204T3	0,9	PFR6B	3500		LPG 1
S 70		2.3	120	5	.99-	B5234S	0,8	BKR6ES	3783	28	LPG 1
S 70		2.3	166	5	09.97-	B5234T	0,8	BCPR7ES	3330		BCPR7EIX
S 70 2.3 T5	874	2.3	176	5	01.97-11.00	B5234T3	0,9	PFR6B	3500		LPG 1
S 70 2.3 T5	874	2.3	177	5	11.96-09.98	B5234T3	0,9	PFR6B	3500		LPG 1
S 70		2.3	177	5	.99-	B5234T5, B5234T6	0,8	BCPR7ES	3330		BCPR7EIX
S 70 2.3 T5	874	2.3	177	5	11.96-12.00	B5234T3	0,9	PFR6B	3500		LPG 1
S 70		2.3	184	5	01.97-11.00	B5234T4, B5234T8	0,9	BKR7E	6097		BKR8EIX
S 70		2.3	184	5	01.97-11.00	B5234T3	0,8	BKR7EIX	2667		BKR8EIX
S 70 2.3 T5	874	2.3	184	5	01.97-11.00	B5234T4	0,9	PFR6B	3500		LPG 1
S 70 2.4		2.4	103	5	08.99-11.00	B5244S2	0,6	BKR6ETUC	3384		LPG 1
S 70 2.4	874	2.4	106	5	11.96-05.99	B5252FS	0,6	BKR6ETUC	3384		LPG 1
S 70 2.4	874	2.4	121	5	10.98-05.99	B5254SDENS	0,6	BKR6ETUC	3384		LPG 1
S 70 2.4		2.4	125	5	01.97-11.00	B5244S	0,6	BKR6ETUC	3384		LPG 1
S 70 2.4 T		2.4	142	5	01.97-11.00	B5244T	0,8	PFR6B	3500		LPG 1
S 70		2.4	195	5	.99-	B5244T2	0,8	BCPR7ES	3330		BCPR7EIX
S 70 2.5 BiFuel		2.5	103	5	07.99-11.00	B5244SG	0,6	BKR6ETUC	3384		LPG 1
S 70 2.5 10V		2.5	106	5	01.97-11.00	B5252S	0,6	BKR6ETUC	3384		LPG 1
S 70 2.5 BiFuel		2.5	106	5	10.98-11.00	GB5252S	0,6	BKR6ETUC	3384		LPG 1
S 70 2.5 20V		2.5	121	5	06.98-11.00	B5254S	0,6	BKR6ETUC	3384		LPG 1
S 70 2.5 T5		2.5	142	5	11.96-04.99	B5254T	0,8	PFR6B	3500		LPG 1

S 80

S 80 2.0 FlexiFuel	124	2.0	107	4	01.08-12.11	B4204S4	1,3	ITR6F13	4477		LPG 5
S 80 2.0	124	2.0	107	4	01.08-09.12	B4204S3	1,3	ITR6F13	4477		LPG 5
S 80 2.0 T5	184	2.0	120	5	11.98-03.01	B5204T4	0,9	PFR6B	3500		LPG 1
S 80 2.0 T5	184	2.0	166	5	11.98-10.00	B5204T3	0,9	PFR6B	3500		LPG 1
S 80 2.3 R	184	2.3	195	5	04.00-03.05	B5234T7	0,9	PFR6B	3500		LPG 1
S 80 2.4 BiFuel	184	2.4	103	5	09.01-07.06	B5244SG2	0,6	BKR6ETUC	3384		LPG 1
S 80 2.4 T5	184	2.4	147	5	08.00-09.03	B5244T3	0,9	PFR6B	3500		LPG 1
S 80 2.5 T5	124	2.5	170	5	01.10-12.12	B5254T10	0,8	ILFR6B	6481		
S 80 2.9	184	2.9	144	6	01.00-07.06	B6294S2	0,5	BKR6EQUA	6872		LPG 1
S 80 2.9	184	2.9	147	6	10.99-10.01	B6294S	0,5	BKR6EQUA	6872		LPG 1
S 80 2.9	184	2.9	150	6	07.98-10.00	B6304S3	0,5	BKR6EQUA	6872		LPG 1
S 80 3.0 T6 (Chassis No 134001→)	124	3.0	210	6	01.07-12.10	B6304T2	1,1	DILFR6A11	97362		
S 80 3.0 T6 (Chassis No →134000)	124	3.0	224	6	01.11-	B6304T4	0,8	ILFR6B	6481		
S 80 3.2 (Chassis No 134001→)	124	3.2	175	6	08.06-12.10	B6324S	1,1	DILFR6A11	97362		
S 80 3.2 (Chassis No 134001→)	124	3.2	175	6	10.06-03.10	B6324S	1,1	DILFR6A11	97362		
S 80 3.2 FlexiFuel (Chassis No 134001→)	124	3.2	177	6	01.09-03.10	B6324S	1,1	DILFR6A11	97362		
S 80 3.2 FlexiFuel (Chassis No →134000)	124	3.2	177	6	01.09-03.10	B6324S	0,8	ILFR6B	6481		
S 80 3.2 (Chassis No →134000)	124	3.2	179	6	09.10-	B6324S5	0,8	ILFR6B	6481		





l kW C
Y
I



Stock-N°

VLINE

LPG/CNG

VOLVO

S 80 I

S 80 2.0 T		2.0	132	5	12.99-12.04	B5204T5	0,8	PFR6B	3500		LPG 1
S 80 2.0 T		2.0	132	5	01.05-07.06	B5204T5	0,8	ILFR6B	6481		
S 80 2.0 T		2.0	166	5	06.98-07.06	B5204T3	0,8	BCPR7ES	3330		BCPR7EIX
S 80 2.3 T		2.3	147	5	.99-07.06	B5234T7	0,8	PFR6B	3500		LPG 1
S 80 2.4		2.4	103	5	01.99-07.06	B5244S2	0,6	BKR6ETUC	3384		LPG 1
S 80 2.4 Bi-Fuel CNG		2.4	103	5	09.01-07.06	B5244SG	0,6	BKR6ETUC	3384		LPG 1
S 80 2.4 Bi-Fuel LPG		2.4	103	5	09.01-07.06	B5244SG2	0,6	BKR6ETUC	3384		LPG 1
S 80 2.4		2.4	125	5	05.98-07.06	B5244S	0,6	BKR6ETUC	3384		LPG 1
S 80 2.4 T		2.4	147	5	06.00-07.06	B5244T3	0,8	PFR6B	3500		LPG 1
S 80 2.4		2.4	147	5	08.00-09.03	B5244T3	0,8	PFR6B	3500		LPG 1
S 80 2.5 T AWD		2.5	154	5	07.03-07.06	B5254T2	0,8	PFR6B	3500		LPG 1
S 80 2.8 T6		2.8	200	6	05.98-07.06	B6284T	0,8	PFR6B	3500		LPG 1
S 80 T6		2.8	200	6	06.98-07.06	B6284T2	0,8	BKR6EIX	6418		LPG 1
S 80 2.9		2.9	144	6	06.01-07.06	B6294S, S2	0,6	BKR6ETUC	3384		LPG 1
S 80 2.9		2.9	147	6	03.99-07.06	B6294S	0,6	BKR6ETUC	3384		LPG 1
S 80 3.0		3.0	147	6	05.98-07.06	B6304S3	0,6	BKR6ETUC	3384		LPG 1
S 80 3.0		3.0	150	6	06.99-07.06	B6304S	0,8	BKR6ES	3783	28	LPG 1
S 80 3.0 T6		3.0	200	6	06.01-07.06	B6294T	0,8	PFR6B	3500		LPG 1

S 80 II

S 80 II T4	AS	1.6	132	4	10.10-	B4164T	0,8	ILZTR6A8G	94769		
S 80 II T4F Flexfuel	AS	1.6	132	4	05.11-	B4164T2	0,8	ILZTR6A8G	94769		
S 80 II 2.0	AS	2.0	107	4	11.07-	B4204S3	1,3	TR6AP-13	5809		LPG 5
S 80 II 2.0 Flexfuel	AS	2.0	107	4	01.08-	B4204S4	1,3	TR6AP-13	5809		LPG 5
S 80 II 2.0 T		2.0	149	4	01.10-	B4204T6	0,8	ILTR6G8G	96621		
S 80 II T5		2.0	177	4	10.10-	B4204T7	0,8	ILTR6G8G	96621		
S 80 II 2.5 T		2.5	147	5	08.06-12.09	B5254T6	0,8	ILFR6B	6481		
S 80 II 2.5 T FlexFuel	AS	2.5	170	5	01.10-	B5254T11	0,8	ILFR6K8	94040		
S 80 II T6 AWD	AS	3.0	210	6	05.07-03.10	B6304T2	0,8	ILFR6B	6481		
S 80 II 3.0 T6 (VIN 134001→)	124	3.0	224	6	01.11-	B6304T4	1,1	DILFR6A11	97362		
S 80 II 3.2 S	AS	3.2	175	6	01.08-03.10	B6324S	0,8	ILFR6B	6481		
S 80 II 3.2 (VIN 134001→)	124	3.2	179	6	09.10-	B6324S5	1,1	DILFR6A11	97362		

S 90

S 90 2.4		2.4	120	6	.97-	B6244F	0,8	BCPR6ES	2330	12	LPG 3
S 90 2.5		2.5	125	6	.97-	B6254F, B6254G	0,8	BCPR6ES	2330	12	LPG 3
S 90 3.0		3.0	132	6	01.97-05.98	B6304S2	0,8	BKR6ES	3783	28	LPG 1
S 90 3.0		3.0	150	6	01.97-05.98	B6304G	0,8	BCPR6ES	2330	12	LPG 3
S 90 3.0		3.0	150	6	01.97-	B6304S	0,8	BKR6ES	3783	28	LPG 1
S 90 3.0		3.0	150	6	.97-	B6304F	0,8	BCPR6ES	2330	12	LPG 3

V 40

V 40 1.9 T4	645	1.9	147	4	10.97-12.00	B4194T, B4194T2	0,9	PFR6B	3500		LPG 1
V 40 2.0 T4	645	2.0	118	4	10.97-01.04	B4204T	0,9	PFR6B	3500		LPG 1

V 40 1

V 40 1.6	VW	1.6	77	4	12.95-08.99	B4164S	0,6	BKR6ETUC	3384		LPG 1
V 40 1.6	VW	1.6	80	4	03.99-05.04	B4164S2	0,6	BKR6ETUC	3384		LPG 1
V 40 1.8	VW	1.8	85	4	07.95-08.99	B4184S	0,6	BKR6ETUC	3384		LPG 1





l kW C
Y
I



Stock-N°

VLINE

LPG/CNG

VOLVO

V 40 1

V 40 1.8	VW	1.8	90	4	03.99-06.04	B4184S2	0,6	BKR6ETUC	3384		LPG 1
V 40 1.8 Bi-Fuel	VW	1.8	90	4	03.99-06.04	B4184S9	0,6	BKR6ETUC	3384		LPG 1
V 40 1.8 GDI	VW	1.8	92	4	08.97-04.04	B4184SJ	0,6	IZFR6B	3116		
V 40 1.8 i	VW	1.8	92	4	04.98-09.00	B4184SM, SJ	0,8	IZFR6B	3116		
V 40		1.8		4	.96-	B4184 S	0,5	BKR6EKUB	3584		LPG 1
V 40 T4	VW	1.9	147	4	05.97-07.00	B4194T, T2	0,8	PFR6G	4793		PFR7G
V 40 2.0	VW	2.0	100	4	07.95-06.04	B4204S, B4204S2	0,6	BKR6ETUC	3384		LPG 1
V 40 2.0	VW	2.0	103	4	07.95-08.99	B4204S	0,6	BKR6ETUC	3384		LPG 1
V 40 2.0 T	VW	2.0	120	4	06.00-04.04	B4204T3	0,8	PFR6B	3500		LPG 1
V 40 2.0 T4	VW	2.0	147	4	07.00-06.04	B4204T5	0,8	PFR6B	3500		LPG 1

V 40 2

V 40 II T2		1.6	88	4	04.13-	B4164T4	0,8	ILZTR6A8G	94769		
V 40 II T3		1.6	110	4	03.12-	B4164T3	0,8	ILZTR6A8G	94769		
V 40 II T4		1.6	132	4	03.12-	B4164T	0,8	ILZTR6A8G	94769		
V 40 II T4		1.6	147	4	04.14-12.15	B4164T	0,8	ILZTR6A8G	94769		

V 50

V 50 1.6	MW	1.6	74	4	01.05-	B4164S3	1,3	TR5B-13	4559	45	LPG 4
V 50 1.8	MW	1.8	92	4	04.04-	B4184S11	1,3	TR6AP-13	5809		LPG 5
V 50 1.8 Flexfuel	MW	1.8	92	4	01.05-	B4184S8	1,3	TR6AP-13	5809		LPG 5
V 50 2.0	MW	2.0	107	4	10.06-	B4204S3	1,3	TR6AP-13	5809		LPG 5
V 50 2.0 Flexfuel	MW	2.0	107	4	01.10-	B4204S4	1,3	TR6AP-13	5809		LPG 5
V 50 2.4	MW	2.4	103	5	04.04-	B5244S5	0,6	LFR6D	4704		
V 50 2.4i	MW	2.4	125	5	04.04-	B5244S4	0,6	LFR6D	4704		
V 50 T5	MW	2.5	162	5	04.04-	B5254T3	0,8	ILFR6B	6481		
V 50 T5	MW	2.5	169	5	03.07-	B5254T7	0,8	ILFR6B	6481		

V 60

V 60 T3		1.6	110	4	09.10-	B4164T3	0,8	ILZTR6A8G	94769		
V 60 T4		1.6	132	4	09.10-	B4164T	0,8	ILZTR6A8G	94769		
V 60 T4F Flexfuel		1.6	132	4	04.11-	B4164T2	0,8	ILZTR6A8G	94769		
V 60 2.0 T		2.0	149	4	09.10-	B4204T6	0,8	ILTR6G8G	96621		
V 60 T5		2.0	176	4	09.10-	B4204T7	0,8	ILTR6G8G	96621		
V 60 3.0 T6	155	3.0	224	6	11.10-12.15	B6304T4	1,1	DILFR6A11	97362		
V 60 3.0 T6/T6 R	155	3.0	242	6	04.14-12.15	B6304T4	1,1	DILFR6A11	97362		
V 60 3.0 T6	155	3.0	258	6	05.14-	B6304T5	1,1	DILFR6A11	97362		

V 70

V 70 2.0	135	2.0	107	4	10.07-11.12	B4204S3	1,3	ITR6F13	4477		LPG 5
V 70 2.0 FlexiFuel	135	2.0	107	4	01.08-11.12	B4204S4	1,3	ITR6F13	4477		LPG 5
V 70 2.0	285	2.0	132	5	03.00-08.07	B5204T5	0,8	ILFR6B	6481		
V 70 2.0 T5	875	2.0	155	5	11.96-09.98	B5204T2	0,9	PFR6B	3500		LPG 1
V 70 2.0 T5	875	2.0	166	5	11.96-02.00	B5204T3	0,9	PFR6B	3500		LPG 1
V 70 2.3 T5	875	2.3	176	5	01.97-03.00	B5234T3	0,9	PFR6B	3500		LPG 1
V 70 2.3 R	875	2.3	177	5	11.96-11.00	B5234T3	0,9	PFR6B	3500		LPG 1
V 70 2.3 R	875	2.3	184	5	04.97-02.00	B5234T4	0,9	PFR6B	3500		LPG 1
V 70 2.3 R	875	2.3	195	5	12.98-02.00	B5234T8	0,9	PFR6B	3500		LPG 1
V 70 2.3 T5	285	2.3	195	5	10.00-09.04	B5234T7	0,9	PFR6B	3500		LPG 1





l kW C
Y
I



Stock-N°

VLIN

LPG/CNG

VOLVO

V 70

V 70 2.4	875	2.4	121	5	10.98-05.99	B5254SDENS	0,6	BKR6ETUC	3384		LPG 1
V 70 2.4 R	875	2.4	195	5	03.99-03.00	B5244T2	0,9	PFR6B	3500		LPG 1
V 70 2.5 T5	135	2.5	170	5	05.09-12.12	B5254T10	0,8	ILFR6B	6481		
V 70 3.0 T6 (Chassis No 167001→)	135	3.0	210	6	08.07-12.10	B6304T2	1,1	DILFR6A11	97362		
V 70 3.0 T6 (Chassis No →167000)	135	3.0	224	6	05.11-	B6304T4	0,8	ILFR6B	6481		
V 70 3.0 T6 (Chassis No 167001→)	135	3.0	242	6	11.13-	B6304T4	1,1	DILFR6A11	97362		
V 70 3.0 T6 (Chassis No →167000)	135	3.0	242	6	11.13-	B6304T4	0,8	ILFR6B	6481		
V 70 3.2 (Chassis No 167001→)	135	3.2	175	6	08.07-11.12	B6324S	1,1	DILFR6A11	97362		
V 70 3.2 (Chassis No 167001→)	135	3.2	175	6	08.07-12.10	B6324S	1,1	DILFR6A11	97362		
V 70 3.2 (Chassis No →167000)	135	3.2	179	6	05.10-	B6324S5	0,8	ILFR6B	6481		

V 70 1

V 70 2.0		2.0	93	5	01.97-03.00	B5202S	0,6	BKR6ETUC	3384		LPG 1
V 70		2.0	105	5	01.97-03.00	B5204S	0,8	BKR6ES	3783	28	LPG 1
V 70 2.0 T		2.0	120	5	01.97-08.00	B5204T4	0,8	PFR6B	3500		LPG 1
V 70 2.0 T		2.0	132	5	01.97-03.00	B5204T2	0,8	PFR6B	3500		LPG 1
V 70		2.0	154	5	01.97-03.00	B5204T	0,8	BCPR7ES	3330		BCPR7EIX
V 70		2.0	166	5	01.97-03.00	B5204T3	0,8	BCPR7ES	3330		BCPR7EIX
V 70		2.3	120	5	01.99-03.00	B5234S	0,8	BKR6ES	3783	28	LPG 1
V 70		2.3	166	5	09.97-03.00	B5234T	0,8	BCPR7ES	3330		BCPR7EIX
V 70		2.3	177	5	.99-03.00	B5234T5, B5234T6	0,8	BCPR7ES	3330		BCPR7EIX
V 70		2.3	184	5	01.97-03.00	B5234T8	0,8	PFR6B	3500		LPG 1
V 70 T5		2.3	184	5	01.97-03.00	B5234T3	0,8	PFR6B	3500		LPG 1
V 70		2.3	184	5	04.97-03.00	B5234T4	0,8	PFR6B	3500		LPG 1
V 70 2.3 T		2.3	195	5	04.99-09.00	B5234T7	0,8	PFR6B	3500		LPG 1
V 70 2.4		2.4	103	5	08.99-05.00	B5244S2	0,6	BKR6ETUC	3384		LPG 1
V 70 Bi-Fuel CNG		2.4	103	5	08.99-03.00	B5244SG	0,6	BKR6ETUC	3384		LPG 1
V 70 Bi-Fuel LPG		2.4	103	5	08.99-03.00	B5244SG2	0,6	BKR6ETUC	3384		LPG 1
V 70		2.4	142	5	01.97-03.00	B5244T	0,8	PFR6B	3500		LPG 1
V 70		2.4	195	5	03.99-03.00	B5244T2	0,8	BCPR7ES	3330		BCPR7EIX
V 70 2.5 10V		2.5	106	5	01.97-03.00	B5252S	0,6	BKR6ETUC	3384		LPG 1
V 70 2.5 BiFuel		2.5	106	5	10.98-08.99	GB5252S	0,6	BKR6ETUC	3384		LPG 1
V 70 2.5 20V		2.5	125	5	01.97-05.00	B5254S	0,6	BKR6ETUC	3384		LPG 1
V 70		2.5	142	5	01.97-03.00	B5254T	0,8	PFR6B	3500		LPG 1

V 70 2

V 70 II 2.0		2.0	107	4	10.07-	B4204S3	1,3	TR6AP-13	5809		LPG 5
V 70 II 2.0 Flexfuel		2.0	107	4	01.08-	B4204S4	1,3	TR6AP-13	5809		LPG 5
V 70 II 2.0 T		2.0	132	5	07.01-08.07	B5204T5	0,8	PFR6B	3500		LPG 1
V 70 II 2.3 T5		2.3	184	5	03.00-08.07	B5234T3	0,8	PFR6B	3500		LPG 1
V 70 II 2.4		2.4	125	5	03.00-	B5244S	0,6	BKR6ETUC	3384		LPG 1
V 70 II 2.4 T		2.4	147	5	03.00-08.07	B5244T3	0,8	PFR6B	3500		LPG 1
V 70 II 2.4 T5		2.4	191	5	04.04-07.07	B5244T5	0,8	ILFR6B	6481		
V 70 II 2.5 T		2.5	154	5	04.04-08.07	B5254T2	0,8	PFR6B	3500		LPG 1
V 70 II R 2.5 T AWD		2.5	220	5	03.03-	B5254T4	0,8	ILFR6B	6481		

V 70 3

V 70 III T4		1.6	132	4	10.10-	B4164T	0,8	ILZTR6A8G	94769		
-------------	--	-----	-----	---	--------	--------	-----	-----------	-------	--	--





l kW C
Y
I



Stock-N°

VLINE

LPG/CNG

VOLVO

V 70 3

V 70 III T4F Flexfuel	1.6	132	4	05.11-	B4164T2	0,8	ILZTR6A8G	94769		
V 70 III 2.0 T	2.0	149	4	01.10-	B4204T6	0,8	ILTR6G8G	96621		
V 70 III T5	2.0	177	4	01.10-	B4204T7	0,8	ILTR6G8G	96621		
V 70 III 2.5 T	2.5	147	5	08.07-12.09	B5254T6	0,8	ILFR6B	6481		
V 70 III 2.5 T FlexFuel	2.5	170	5	10.09-	B5254T11	0,8	ILFR6K8	94040		
V 70 III T6 AWD (Chassis No →167000)	3.0	210	6	08.07-	B6304T2	0,8	ILFR6B	6481		
V 70 III 3.0 T6 (VIN 167001→)	135	3.0	224	6	05.11-	B6304T4	1,1	DILFR6A11	97362	
V 70 III 3.2	3.2	175	6	08.07-	B6324S	0,8	ILFR6B	6481		
V 70 III 3.2 (VIN 167001→)	135	3.2	179	6	05.10-	B6324S5	1,1	DILFR6A11	97362	

V 90

V 90	2.4	120	6	.97-	B6244F	0,8	BCPR6ES	2330	12	LPG 3
V 90	2.5	125	6	.97-	B6254F, B6254G	0,8	BCPR6ES	2330	12	LPG 3
V 90	2.9	150	6	.97-	B6304F, B6304G	0,8	BCPR6ES	2330	12	LPG 3
V 90 3.0	3.0	132	6	01.97-	B6304S2	0,8	BKR6ES	3783	28	LPG 1
V 90 3.0	3.0	150	6	01.97-	B6304S	0,8	BKR6ES	3783	28	LPG 1

XC 60

XC60 2.0 T	2.0	149	4	01.10-	B4204T6	0,8	ILTR6G8G	96621		
XC60 T5	2.0	177	4	09.10-	B4204T7	0,8	ILTR6G8G	96621		
XC60 3.0 T6 (Chassis No 135000→)	156	3.0	210	6	07.08-03.10	B6304T2	1,1	DILFR6A11	97362	
XC60 3.0 T6 AWD	3.0	210	6	10.08-	B6304T2	0,8	ILFR6B	6481		
XC60 3.0 T6 (Chassis No →134999)	156	3.0	224	6	03.09-02.17	B6304T4	0,8	ILFR6B	6481	
XC60 3.0 T6 (VIN 135000→)	156	3.0	224	6	03.10-12.15	B6304T4	1,1	DILFR6A11	97362	
XC60 3.0 T6 (VIN 135000→)	156	3.0	242	6	04.14-12.15	B6304T4	1,1	DILFR6A11	97362	
XC60 3.0 T6 (Chassis No →134999)	156	3.0	242	6	04.14-12.15	B6304T4	0,8	ILFR6B	6481	
XC60 3.2 (Chassis No 135000→)	156	3.2	175	6	05.09-12.10	B6324S	1,1	DILFR6A11	97362	
XC60 3.2 T5 (VIN 135000→)	156	3.2	179	6	04.10-	B6324S5	1,1	DILFR6A11	97362	
XC60 3.2 T5 (Chassis No →134999)	156	3.2	179	6	04.10-02.17	B6324S5	0,8	ILFR6B	6481	

XC 70

XC70 3.0 T6 (Chassis No 94001→)	136	3.0	210	6	01.08-11.12	B6304T2	1,1	DILFR6A11	97362	
XC70 3.0 T6 (Chassis No →94000)	136	3.0	224	6	01.10-	B6304T4	0,8	ILFR6B	6481	
XC70 3.0 T6 Polestar (Chassis No 94001-→)	136	3.0	242	6	11.13-	B6304T4	1,1	DILFR6A11	97362	
XC70 3.0 T6 Polestar (Chassis No →94000)	136	3.0	242	6	11.13-	B6304T4	0,8	ILFR6B	6481	
XC70 3.2 (Chassis No 94001→)	136	3.2	175	6	08.07-12.10	B6324S	1,1	DILFR6A11	97362	
XC70 3.2 (Chassis No →94000)	136	3.2	179	6	10.10-	B6324S5	0,8	ILFR6B	6481	

XC 70 1

XC70 2.4T	2.4	147	5	09.00-09.02	B5244T3	0,8	PFR6B	3500		LPG 1
XC70 2.5T	2.5	154	5	09.02-08.07	B5254T2	0,8	PFR6B	3500		LPG 1
XC70 3.0 T6 AWD	3.0	210	6	01.08-	B6304T2	0,8	ILFR6B	6481		
XC70 3.2 AWD	3.2	175	6	02.07-	B6324S	0,8	ILFR6B	6481		

XC 70 2

XC70 II 3.0 T6 (VIN 94001→)	136	3.0	224	6	01.10-	B6304T4	1,1	DILFR6A11	97362	
XC70 II 3.2 (VIN 94001→)	136	3.2	179	6	10.10-	B6324S5	1,1	DILFR6A11	97362	

XC 90

XC90 2.5T	2.5	154	5	10.02-	B5254T2	0,8	PFR6B	3500		LPG 1
-----------	-----	-----	---	--------	---------	-----	-------	------	--	-------





l kW C
Y
I



Stock-N°

VLINE

LPG/CNG

VOLVO

XC 90

XC90 T6 Biturbo		2.9	200	6	10.02-	B6294T	0,8	PFR6B	3500		LPG 1
XC90 3.2 (Chassis No 568001→)	275	3.2	175	6	04.06-12.14	B6324S	1,1	DILFR6A11	97362		
XC90 3.2		3.2	175	6	05.06-	B6324S	0,8	ILFR6B	6481		
XC90 3.2 (Chassis No 568001→)	275	3.2	175	6	09.11-12.14	B6324S5	1,1	DILFR6A11	97362		
XC90 3.2 (Chassis No →568000)	275	3.2	175	6	09.11-12.14	B6324S5	0,8	ILFR6B	6481		
XC90 3.2 (Chassis No 568001→)	275	3.2	179	6	04.11-12.14	B6324S5	1,1	DILFR6A11	97362		
XC90 3.2 (Chassis No →568000)	275	3.2	179	6	04.11-12.14	B6324S5	0,8	ILFR6B	6481		
XC90 4.4		4.4	232	8	11.04-	B8444S	1,1	IFR6B-11	5368		

WIESMANN

GT

Coupe GT MF4		4.4	245	8	.05- .05	N62 B44	1,5	BKR6EQUP	3199	30	LPG 1
Coupe GT MF4		4.8	270	8	09.05-	N62 B48	1,1	IZFR6H11	4294		
Coupe GT MF5		5.0	373	10	.07-	S85 B50	0,9	LKR8AP	4471		

MF28

Roadster MF28		2.8	142	6	.95-	M52 B28	0,9	BKR6EK	2288	20	LPG 1
---------------	--	-----	-----	---	------	---------	-----	--------	------	----	-------

MF3

Roadster MF3		3.2	236	6	.95-11.01	S50 B32	0,7	PKR7A	3641		
Roadster MF3		3.2	252	6	12.01-	S54 B32	0,9	DCPR8EKP	7415		

MF4

Roadster MF4-S		4.0	309	8	03.09-	S65 B40	0,9	LKR8AP	4471		
----------------	--	-----	-----	---	--------	---------	-----	--------	------	--	--

YUGO

YUGO

Yugo 45,55,65,Florida				4	.80-		0,7	BP6ES	7811	4	LPG 2
-----------------------	--	--	--	---	------	--	-----	-------	------	---	-------

Z.A.Z.

1102

1102 Tawrija		1.1	37	4	06.90-		0,7	BP6ES	7811	4	LPG 2
1102 Tawrija		1.3	44	4	06.90-		0,7	BP6ES	7811	4	LPG 2

MEGANE

Megane kombi		1.1	37	4	06.90-		0,7	BP6ES	7811	4	LPG 2
--------------	--	-----	----	---	--------	--	-----	-------	------	---	-------

ZASTAVA

55 / 60 / 65 / 750 / 850 / 1300 / FLORIDA / SANA

55				4	.82-		0,7	BP6ES	7811	4	LPG 2
60				4	.82-		0,7	BP6ES	7811	4	LPG 2
65				4	.82-		0,7	BP6ES	7811	4	LPG 2
850				4	.78-		0,6	BP6HS	4511	18	BPR7HIX
1300				4	-12.93		0,7	BP6ES	7811	4	LPG 2
65 EFI		1.3		4	.89-		0,8	BPR6ES	7822	2	LPG 2
65 Skala				4	.72-		0,7	BP6ES	7811	4	LPG 2
750				4	.78-		0,6	BP6HS	4511	18	BPR7HIX
Florida 1.4		1.4	48	4	07.89-12.93		0,8	BPR6ES	7822	2	LPG 2
Florida 1.6		1.6	62	4	07.89-12.93		0,8	BPR6ES	7822	2	LPG 2
Florida EFI		1.4	53	4	10.88-12.93		0,8	BPR6ES	7822	2	LPG 2
Sana 1.4		1.4	53	4	.89-		0,8	BPR6ES	7822	2	LPG 2



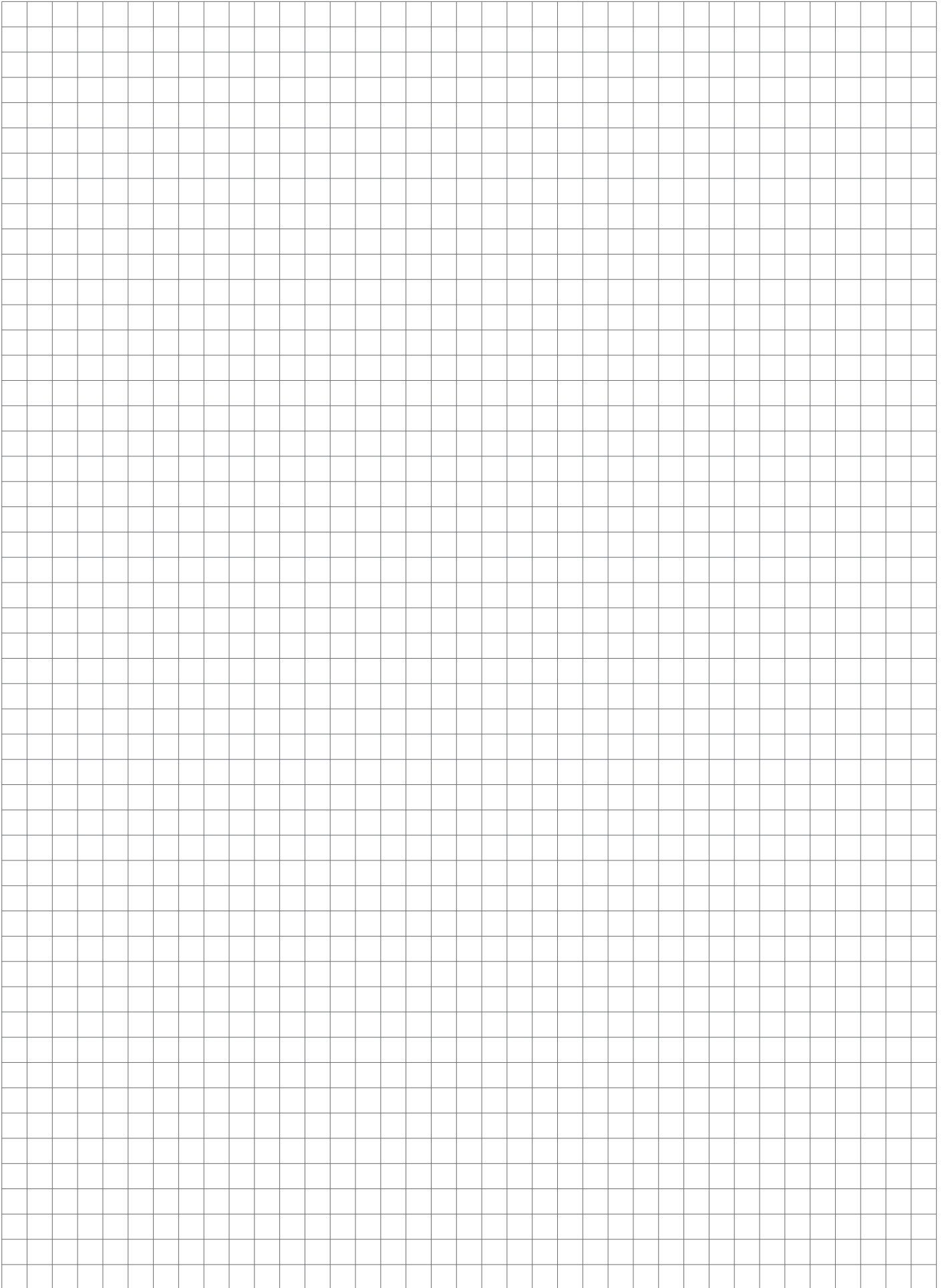





IGNITION
PARTS



l kW C
y
i



Stock-No
D-POWER

ALFA ROMEO

33

33 TD		1.8	55	4	09.86-03.94		11,0	Y-909R	4602	
33 TD		1.8	62	3	09.86-03.94	VM HR-392	11,0	Y-909R	4602	
33 TD Sport Wagon		1.8	62	4	01.90-03.94	VM 96 A	11,0	Y-909R	4602	
33 TD		1.8	62	4	02.90-03.94	VM 82 A	11,0	Y-909R	4602	

75 (162B)

75 TD	162B	2.0	70	4	05.85-02.92	VM 80 A	11,0	Y-909R	4602	
75 TD	162B	2.4	81	4	10.88-02.92	VM 81 A	11,0	Y-909R	4602	

145 (930)

145 1.9 TD	930	1.9	66	4	04.94-09.96	AR67.501	11,0	Y-924J	7906	1
145 1.9 TD	930	1.9	66	4	10.96-09.97	AR33.601	11,0	Y-924J	7906	1
145 1.9 JTD (Engine No→1716458)	930	1.9	77	4	02.99-10.99	AR32.302	11,0	Y-747U	4694	26
145 1.9 JTD (Engine No1716459→)	930	1.9	77	4	11.99-01.01	AR32.302	11,0	Y-534J	3413	36

146 (930)

146 1.9 TD	930	1.9	66	4	02.95-09.96	AR67 501	11,0	Y-924J	7906	1
146 1.9 TD	930	1.9	66	4	10.96-09.97	AR33.601	11,0	Y-924J	7906	1
146 1.9 JTD (Engine No→1716458)	930	1.9	77	4	02.99-10.99	AR32.302	11,0	Y-747U	4694	26
146 1.9 JTD (Engine No1716459→)	930	1.9	77	4	11.99-01.01	AR32.302	11,0	Y-534J	3413	36

147 (937)

147 1.9 JTD	937	1.9	74	4	11.00-05.03	182B9000	11,0	Y-534J	3413	36
147 1.9 JTD	937	1.9	85	4	06.03-06.05	937A2000	11,0	Y-534J	3413	36
147 1.9 JTDM	937	1.9	85	4	10.04-09.07	939A7000	11,0	Y1030J	90828	70
147 1.9 JTDM 8V	937	1.9	88	4	07.05-	937A3000	11,0	Y1030J	90828	70
147 1.9 JTD 16V	937	1.9	93	4	09.03-05.05	937A4000	11,0	YE07	6092	
147 1.9 JTD 16V	937	1.9	100	4	10.04-	192B1000	11,0	YE07	6092	
147 1.9 JTD 16V	937	1.9	103	4	11.03-	192A5000	11,0	YE07	6092	
147 1.9 JTD MJET 16V	937	1.9	110	4	07.04-	937A5000	11,0	YE07	6092	

155 (167)

155 TD	167	2.5	92	4	04.93-04.95	VM 425 CLIEA	11,0	Y-924J	7906	1
155 TD	167	2.5	92	4	05.95-10.97	VM 425 CLIEA	11,0	Y-741U	6943	20
155 TD	167	1.9	68	4	04.93-04.96	AR67.501	11,0	Y-924J	7906	1
155 TD	167	2.0	66	4	08.93-04.96	AR67.502	11,0	Y-924J	7906	1

156 (932)

156 1.9 JTD	932	1.9	77	4	10.97-09.00	AR32.302	11,0	Y-747U	4694	26
156 1.9 JTD	932	1.9	81	4	10.00-05.01	AR37.101	11,0	Y-534J	3413	36
156 1.9 JTD	932	1.9	85	4	05.01- .05	937A2000	11,0	Y-534J	3413	36
156 1.9 JTD	932	1.9	93	4	11.03-09.05	937A4000	11,0	YE07	6092	
156 1.9 JTD	932	1.9	100	4	11.02-11.04	192B1000	11,0	YE07	6092	
156 1.9 JTD 16V	932	1.9	103	4	11.02-09.05	192A5000	11,0	YE07	6092	
156 1.9 JTD 16V	932	1.9	110	4	07.04-09.05	937A5000	11,0	YE07	6092	
156 2.4 JTD	932	2.4	100	5	10.97-09.00	AR32.501	11,0	Y-747U	4694	26
156 2.4 JTD	932	2.4	103	5	10.00-02.02	839A6000	11,0	Y-534J	3413	36
156 2.4 JTD	932	2.4	110	5	03.02-01.04	841C000	11,0	Y-534J	3413	36
156 2.4 JTD	932	2.4	120	5	06.03-09.05	841M000, 841N000	11,0	YE07	6092	
156 2.4 JTD 20V	932	2.4	129	5	10.03-05.06	841G000	11,0	YE07	6092	





e kW C
y
i



Stock-No
D-POWER™

ALFA ROMEO

159 (939)

159 1.9 JTDM 8V	939	1.9	85	4	09.05-11.11	937A7000, 939A7000	11,0	Y1030J	90828	70
159 1.9 JTDM 8V	939	1.9	88	4	09.05-11.11	939A1000	11,0	Y1030J	90828	70
159 1.9 JTDM 16V	939	1.9	100	4	09.05-12.10	937A8000, 939A8000	11,0	YE07	6092	
159 1.9 JTDM 16V	939	1.9	110	4	07.05-11.11	939A2000	11,0	YE07	6092	
159 2.0 JTDM	939	2.0	100	4	06.10-11.11	939B4000	4,4	Y9003AS	94251	78
159 2.0 JTDM	939	2.0	120	4	05.09-11.11	844A2000	4,4	Y9003AS	94251	78
159 2.0 JTDM	939	2.0	125	4	03.09-11.11	939B3000	4,4	Y9003AS	94251	78
159 2.4 JTDM 20V	939	2.4	147	5	12.05-04.07	939A3000	11,0	YE07	6092	
159 2.4 JTDM 20V	939	2.4	154	5	05.07-12.08	939A9000	11,0	YE07	6092	

164 (164)

164 TD	164	2.5	85	4	06.87-08.92	VM 84 A	11,0	Y-909R	4602	
164 TD Super	164	2.5	92	4	09.92-04.95	VM 425-SLIRA	11,0	Y-924J	7906	1
164 TD	164	2.5	92	4	05.95-10.98	VM 425 SLIRA	11,0	Y-741U	6943	20

166 (936)

166 2.4 JTD	936	2.4	100	5	10.98-10.00	AR34.202	11,0	Y-747U	4694	26
166 2.4 JTD	936	2.4	103	5	11.00-03.02	839A600	11,0	Y-534J	3413	36
166 2.4 JTD	936	2.4	110	5	04.02-10.03	841C000	11,0	Y-534J	3413	36
166 2.4 JTD	936	2.4	129	5	10.03-06.08	841G000, 841H000	11,0	YE07	6092	
166 2.4 JTD MJET 20V	936	2.4	132	5	07.06-06.08	936B000, 841M000	11,0	YE07	6092	
166 2.4 JTD MJET 20V	936	2.4	136	5	07.05-06.08	936B000, 841M000	11,0	YE07	6092	

BRERA

Brera 2.0 JTDM		2.0	120	4	03.08-12.11	844A2000	4,4	Y9003AS	94251	78
Brera 2.0 JTDM		2.0	125	4	03.09-03.11	939B3000	4,4	Y9003AS	94251	78
Brera 2.4 JTDM 20V		2.4	147	5	01.06-03.11	939A3000	11,0	YE07	6092	

GIULIETTA (940)

Giulietta 1.6 JTDM	940	1.6	77	4	03.10-	940A3000	4,4	Y9003AS	94251	78
Giulietta 2.0 JTDM	940	2.0	100	4	04.10-	940A8000	4,4	Y9003AS	94251	78
Giulietta 2.0 JTDM	940	2.0	103	4	04.10-	940A5000	4,4	Y9003AS	94251	78
Giulietta 2.0 JTDM	940	2.0	120	4	04.10-	940A7000	4,4	Y9003AS	94251	78
Giulietta 2.0 JTDM	940	2.0	125	4	03.10-	940A4000	4,4	Y9003AS	94251	78
Giulietta 2.0 JTDM	940	2.0	129	4	11.13-	940B4000	4,4	Y9003AS	94251	78

GT (937)

GT 1.9 JTDM 16V	937	1.9	110	4	12.03-	937A5000	11,0	YE07	6092	
GT 1.9 JTDM 16V	937	1.9	125	4	05.08-	937A6000	11,0	YE07	6092	

MITO (955)

MITO 1.3 JTDM 16V Eco	955	1.3	62	4	01.11-	199B4000	4,3	Y9001AS	97719	72
MITO 1.3 JTDM	955	1.3	66	4	08.08-12.11	199A3000	4,3	Y9001AS	97719	72
MITO 1.3 JTDM (For OE-No. 55238404 / 55210051)	955, 955AX-P1A	1.3	70	4	09.09-	199B1000	4,3	Y9001AS	97719	72
MITO 1.3 JTDM (For OE-No. 55238404)	955, 955AX-P1A	1.3	70	4	09.09-	330A1000	4,3	Y9001AS	97719	72
MITO 1.6 JTDM 16V	955	1.6	85	4	08.08-	955A4000	4,4	Y9003AS	94251	78
MITO 1.6 JTDM 16V	955	1.6	88	4	08.08-	955A3000	4,4	Y9003AS	94251	78

SPIDER (939)

Spider 2.0 JTDM	939	2.0	120	4	04.09-12.11	844A2000	4,4	Y9003AS	94251	78
Spider 2.0 JTDM	939	2.0	125	4	03.09-12.11	939B3000	4,4	Y9003AS	94251	78





l kW C
y
i



Stock-No
D-POWER

ALFA ROMEO

SPIDER (939)

Spider 2.4 JTDM	939	2.4	147	5	02.06-	939 A3.000	11,0	YE07	6092	
Spider 2.4 JTDM	939	2.4	154	5	03.08-	939 A9.000	11,0	YE07	6092	

ALPINA

D 3

D 3 2.0	E90	2.0	147	4	02.07-	N47D20 L1	5,0	Y-547AS	5968	47
---------	-----	-----	-----	---	--------	-----------	-----	---------	------	----

ASIA MOTORS

ROCSTA

Rocsta 2.2		2.2		4	03.94-12.97	R2	10,5	Y-107R	1229	
------------	--	-----	--	---	-------------	----	------	--------	------	--

AUDI

80 (B4)

80 1.9 TD	B4	1.9	55	4	09.91-07.95	AAZ	12,0	Y-918J	6285	2
80 1.9 TDI	B4	1.9	66	4	09.91-07.95	1Z	12,0	Y-732J	5605	4

A1 (8X)

A1 1.4 TDI (only for cyl. without pressure sensor)	8XK, 8XF	1.4	66	3	11.14-	CUSB	4,4	Y1002AS	8888	57
A1 1.6 TDI	8X1, 8XA	1.6	66	4	11.10-	CAYB	4,4	Y1002AS	8888	57
A1 1.6 TDI	8X1, 8XA	1.6	77	4	05.10-	CAYC	4,4	Y1002AS	8888	57
A1 1.6 TDI (only for cyl. without pressure sensor)	8XK, 8XF	1.6	85	4	11.14-	CXMA	4,4	Y1002AS	8888	57
A1 2.0 TDI	8X1, 8XA	2.0	100	4	05.12-	CFHB	4,4	Y1002AS	8888	57
A1 2.0 TDI	8X1, 8XA	2.0	105	4	08.11-	CFHD	4,4	Y1002AS	8888	57

A2 (8Z0)

A2 1.2 TDI	8Z0	1.2	45	3	03.01-08.05	ANY	11,0	Y-741U	6943	20
A2 1.4 TDI	8Z0	1.4	55	3	06.00-08.03	AMF	11,0	Y-741U	6943	20
A2 1.4 TDI	8Z0	1.4	55	3	09.03-08.05	BHC	11,0	Y-741U	6943	20
A2 1.4 TDI	8Z0	1.4	66	3	11.03-08.05	ATL	5,0	Y-607AS	7560	50

A3 1 (8L1)

A3 1.9 TDI	8L1	1.9	66	4	09.96-08.00	AGR	12,0	Y-732J	5605	4
A3 1.9 TDI	8L1	1.9	66	4	08.97-06.01	ALH	12,0	Y-732J	5605	4
A3 1.9 TDI (VIN→8L-2-037-877)	8L1	1.9	74	4	01.01-06.03	ATD	12,0	Y-732J	5605	4
A3 1.9 TDI (VIN 8L-2-037-878→)	8L1	1.9	74	4	01.01-06.03	ATD	11,0	Y-741U	6943	20
A3 1.9 TDI (VIN→8L-2-037-877)	8L1	1.9	74	4	11.01-06.03	AXR	12,0	Y-732J	5605	4
A3 1.9 TDI (VIN 8L-2-037-878→)	8L1	1.9	74	4	11.01-06.03	AXR	11,0	Y-741U	6943	20
A3 1.9 TDI	8L1	1.9	81	4	01.97-04.02	AHF	12,0	Y-732J	5605	4
A3 1.9 TDI	8L1	1.9	81	4	09.99-06.01	ASV	12,0	Y-732J	5605	4
A3 1.9 TDI (VIN→8L-2-037-877)	8L1	1.9	96	4	05.00-06.03	ASZ	12,0	Y-732J	5605	4
A3 1.9 TDI (VIN 8L-2-037-878→)	8L1	1.9	96	4	05.00-06.03	ASZ	11,0	Y-741U	6943	20

A3 2 (8P1/8PA/8P7)

A3 1.6 TDI	8P1, 8PA	1.6	66	4	05.09-08.12	CAYB	4,4	Y1002AS	8888	57
A3 1.6 TDI	8P1, 8PA	1.6	77	4	05.09-08.12	CAYC	4,4	Y1002AS	8888	57
A3 1.9 TDI	8P1, 8PA	1.9	77	4	06.03-05.06	BKC	5,0	Y-607AS	7560	50
A3 1.9 TDI	8P1, 8PA	1.9	77	4	10.05-05.07	BLS	5,0	Y-607AS	7560	50
A3 1.9 TDI	8P1, 8PA	1.9	77	4	06.06-05.10	BXE	5,0	Y-607AS	7560	50
A3 2.0 TDI	8P1, 8PA	2.0	100	4	05.03-05.07	AZV	4,4	YE14	7768	48
A3 2.0 TDI	8P1, 8PA	2.0	100	4	04.08-05.10	CBAA	4,4	Y-609AS	5849	49





e kW C y i



Stock-No
D-POWER

AUDI

A3 2 (8P1/8PA/8P7)

A3 2.0 TDI	8P1, 8PA	2.0	100	4	11.09-08.12	CFFA	4,4	Y1002AS	8888	57
A3 2.0 TDI	8P1, 8PA	2.0	103	4	05.03-05.07	BKD	4,4	YE14	7768	48
A3 2.0 TDI (VIN 8P-6A138000→8P-6B019000)	8P1, 8PA	2.0	103	4	02.05-06.08	BMM	7,0	CZ104	9826	52
A3 2.0 TDI (VIN 8P-6A138001→8P-6B019001)	8P1, 8PA	2.0	103	4	02.05-06.08	BMM	5,0	Y-607AS	7560	50
A3 2.0 TDI	8P1, 8PA	2.0	103	4	04.08-05.10	CBAB	4,4	Y-609AS	5849	49
A3 2.0 TDI	8P1, 8PA	2.0	103	4	11.09-08.12	CFFB	4,4	Y1002AS	8888	57
A3 2.0 TDI	8P1, 8PA	2.0	103	4	02.10-08.12	CLJA	4,4	Y1002AS	8888	57
A3 2.0 TDI	8P1, 8PA	2.0	120	4	06.06-05.07	BUY	7,0	CZ304	9864	55
A3 2.0 TDI	8P1, 8PA	2.0	125	4	03.06-08.12	BMN	7,0	CZ304	9864	55
A3 2.0 TDI	8P1, 8PA	2.0	125	4	07.08-05.10	CBBB	4,4	Y-609AS	5849	49
A3 2.0 TDI	8P1, 8PA	2.0	125	4	05.10-08.12	CFGB	4,4	Y1002AS	8888	57

A3 3 (8V1/8VA)

A3 2.0 TDI (only for cyl. without pressure sensor)	8V1, 8VA, 8VS	2.0	105	4	09.12-	CRFC	4,4	Y1002AS	8888	57
--	---------------	-----	-----	---	--------	------	-----	---------	------	----

A3 3 (8V1/8VA/8VS)

A3 1.6 TDI (only for cyl. without pressure sensor)	8V1, 8VA, 8VS	1.6	77	4	09.12-	CLHA	4,4	Y1002AS	8888	57
A3 1.6 TDI (only for cyl. without pressure sensor)	8V1, 8VA, 8VS, 8V7	1.6	81	4	09.13-	CRKB	4,4	Y1002AS	8888	57
A3 2.0 TDI (only for cyl. without pressure sensor)	8V1, 8VA, 8VS	2.0	81	4	01.13-	CRFA	4,4	Y1002AS	8888	57
A3 2.0 TDI (only for cyl. without pressure sensor)	8V1, 8VA, 8VS	2.0	100	4	05.13-	CRBD	4,4	Y1002AS	8888	57
A3 2.0 TDI (only for cyl. without pressure sensor)	8V1, 8VA, 8VS	2.0	110	4	04.12-	CRBC	4,4	Y1002AS	8888	57
A3 2.0 TDI (only for cyl. without pressure sensor)	8V1, 8VA, 8VS, 8V7	2.0	110	4	04.12-	CRLB	4,4	Y1002AS	8888	57
A3 2.0 TDI (only for cyl. without pressure sensor)	8V1, 8VA, 8VS, 8V7	2.0	135	4	12.12-	CUNA	4,4	Y1002AS	8888	57

A4 1 (8D2/8D5 B5)

A4 1.9 TDI	8D2, 8D5B5	1.9	55	4	03.96-06.00	AFF	12,0	Y-732J	5605	4
A4 1.9 TDi (color code: Black)	8D2	1.9	55	4	03.96-06.00	AFF	12,0	Y-918J	6285	2
A4 1.9 TDI	8D2, 8D5B5	1.9	66	4	11.94-07.96	1Z	12,0	Y-732J	5605	4
A4 1.9 TDi (color code: Black)	8D2	1.9	66	4	01.95-10.01	1Z	12,0	Y-918J	6285	2
A4 1.9 TDi (color code: Black)	8D2	1.9	66	4	01.95-09.01	AHH	12,0	Y-918J	6285	2
A4 1.9 TDi (color code: Black)	8D2	1.9	66	4	01.95-09.01	AHU	12,0	Y-918J	6285	2
A4 1.9 TDI	8D2, 8D5B5	1.9	66	4	08.96-06.00	AHU	12,0	Y-732J	5605	4
A4 1.9 TDI	8D2, 8D5B5	1.9	66	4	04.97-09.01	AHH	12,0	Y-732J	5605	4
A4 1.9 TDI	8D2, 8D5B5	1.9	81	4	02.96-07.99	AFN	12,0	Y-732J	5605	4
A4 1.9 TDi (color code: Black)	8D2, 8D5	1.9	81	4	02.96-06.00	AFN	12,0	Y-918J	6285	2
A4 1.9 TDi (color code: Black)	8D2, 8D5	1.9	81	4	02.96-06.00	AVG	12,0	Y-918J	6285	2
A4 1.9 TDI	8D2, 8D5B5	1.9	81	4	08.99-06.00	AVG	12,0	Y-732J	5605	4
A4 1.9 TDI	8D2, 8D5B5	1.9	85	4	08.98-09.01	AJM	12,0	Y-732J	5605	4
A4 1.9 TDI	8D2, 8D5B5	1.9	85	4	01.00-09.01	ATJ	12,0	Y-732J	5605	4
A4 2.5 V6 TDI	8D2, 8D5B5	2.5	110	6	11.97-06.00	AFB	11,0	Y-501U	4187	31
A4 2.5 V6 TDI	8D2, 8D5B5	2.5	110	6	07.98-09.01	AKN	11,0	Y-501U	4187	31

A4 2 (8E2/8E5 B6)

A4 1.9 TDI (VIN→8E-2-148-697)	8E2, 8E5	1.9	74	4	04.01-05.04	AVB	12,0	Y-732J	5605	4
A4 1.9 TDI (VIN 8E-2-148-698→)	8E2, 8E5	1.9	74	4	04.01-05.04	AVB	11,0	Y-741U	6943	20
A4 1.9 TDI (VIN 8E-5-070251→)	8E2, 8E5	1.9	85	4	06.04-12.05	BKE	5,0	Y-607AS	7560	50





kw
C
Y
I



Stock-No
D-POWER

AUDI

A4 2 (8E2/8E5 B6)

A4 1.9 TDI (VIN→8E-2-148-697)	8E2, 8E5	1.9	96	4	11.00-12.04	AVF	12,0	Y-732J	5605	4
A4 1.9 TDI (VIN 8E-2-148-698→)	8E2, 8E5	1.9	96	4	11.00-12.04	AVF	11,0	Y-741U	6943	20
A4 1.9 TDI (VIN→8E-2-148-697)	8E2, 8E5	1.9	96	4	12.00-06.03	AWX	12,0	Y-732J	5605	4
A4 1.9 TDI (VIN 8E-2-148-698→)	8E2, 8E5	1.9	96	4	12.00-06.03	AWX	11,0	Y-741U	6943	20
A4 2.5 V6 TDI	8E2, 8E5	2.5	114	6	04.01-06.02	AYM	11,0	Y-501U	4187	31
A4 2.5 V6 TDI	8E2, 8E5	2.5	120	6	07.02-05.03	BFC	11,0	Y-501U	4187	31
A4 2.5 V6 TDI	8E2, 8E5	2.5	120	6	06.03-12.05	BCZ	11,0	Y-501U	4187	31
A4 2.5 V6 TDI	8E2, 8E5	2.5	120	6	06.03-10.04	BDG	11,0	Y-501U	4187	31
A4 2.5 V6 TDI	8E2, 8E5	2.5	132	6	12.00-05.03	AKE	11,0	Y-501U	4187	31
A4 2.5 V6 TDI	8E2, 8E5	2.5	132	6	06.03-12.04	BAU	11,0	Y-501U	4187	31
A4 2.5 V6 TDI	8E2, 8E5	2.5	132	6	06.03-12.04	BDH	11,0	Y-501U	4187	31

A4 3 (8EC/8ED)

A4 1.9 TDI	8EC, 8ED	1.9	85	4	11.05-	BRB	7,0	CZ104	9826	52
A4 2.0 TDI	8EC, 8ED	2.0	89	4	01.06-09.06	BVG	7,0	CZ304	9864	55
A4 2.0 TDI	8EC, 8ED	2.0	93	4	11.05-11.06	BVF	7,0	CZ304	9864	55
A4 2.0 TDI	8EC, 8ED	2.0	100	4	11.04-10.05	BNA	4,4	YE14	7768	48
A4 2.0 TDI	8EC, 8ED	2.0	100	4	11.05-	BRF	7,0	CZ304	9864	55
A4 2.0 TDI	8EC, 8ED	2.0	103	4	11.04-	BPW	7,0	CZ104	9826	52
A4 2.0 TDI	8EC, 8ED	2.0	103	4	11.04-11.05	BLB	4,4	YE14	7768	48
A4 2.0 TDI	8EC, 8ED	2.0	103	4	10.05-	BRE	7,0	CZ304	9864	55
A4 2.0 TDI	8EC, 8ED	2.0	120	4	06.06-	BVA	7,0	CZ304	9864	55
A4 2.0 TDI	8EC, 8ED	2.0	125	4	06.06-	BRD	7,0	CZ304	9864	55
A4 2.5 V6 TDI	8EC, 8ED	2.5	120	6	11.04-05.06	BDG	11,0	Y-501U	4187	31
A4 2.7 V6 TDI	8EC, 8ED	2.7	120	6	11.05-06.08	BSG	4,4	Y-609AS	5849	49
A4 2.7 V6 TDI	8EC, 8ED	2.7	132	6	01.06-03.09	BPP	4,4	Y-609AS	5849	49
A4 3.0 V6 TDI	8EC, 8ED	3.0	150	6	11.04-03.09	BKN	4,4	Y-609AS	5849	49
A4 3.0 V6 TDI	8EC, 8ED	3.0	171	6	01.06-03.09	ASB	4,4	Y-609AS	5849	49

A4 4 (8K2/8K5)

A4 2.0 TDI	8K2, 8K5	2.0	88	4	06.08-	CAGC	4,4	Y-609AS	5849	49
A4 2.0 TDI	8K2, 8K5	2.0	100	4	11.07-	CAGB	4,4	Y-609AS	5849	49
A4 2.0 TDI	8K2, 8K5	2.0	100	4	11.10-	CJCB	4,4	Y1002AS	8888	57
A4 2.0 TDI	8K2, 8K5	2.0	105	4	11.07-	CAGA	4,4	Y-609AS	5849	49
A4 2.0 TDI	8K2, 8K5	2.0	105	4	05.10-	CMEA	4,4	Y1002AS	8888	57
A4 2.0 TDI (only for cyl. without pressure sensor)	8K2, 8K5	2.0	110	4	05.13-	CJCD	4,4	Y1002AS	8888	57
A4 2.0 TDI (only for cyl. without pressure sensor)	8K2, 8K5	2.0	110	4	05.13-	CMFB	4,4	Y1002AS	8888	57
A4 2.0 TDI	8K2, 8K5	2.0	120	4	08.08-	CAHB	4,4	Y-609AS	5849	49
A4 2.0 TDI	8K2, 8K5	2.0	125	4	08.08-	CAHA	4,4	Y-609AS	5849	49
A4 2.0 TDI	8K2, 8K5	2.0	130	4	11.11-	CGLC	4,4	Y1002AS	8888	57
A4 2.0 TDI (only for cyl. without pressure sensor)	8K2, 8K5	2.0	140	4	09.13-	CNHA	4,4	Y1002AS	8888	57
A4 2.7 V6 TDI	8K2, 8K5	2.7	120	6	11.07-05.08	CAMB	4,4	Y-609AS	5849	49
A4 2.7 V6 TDI	8K2, 8K5	2.7	140	6	11.07-05.08	CAMA	4,4	Y-609AS	5849	49
A4 3.0 V6 TDI (only for cyl. without pressure sensor)	8K2, 8K5	3.0	150	6	11.11-	CLAB	4,4	Y1002AS	8888	57
A4 3.0 V6 TDI	8K2, 8K5	3.0	155	6	06.08-05.10	CCWB	4,4	Y-609AS	5849	49
A4 3.0 V6 TDI	8K2, 8K5	3.0	176	6	11.07-05.08	CAPA	4,4	Y-609AS	5849	49





e kW C
y i



Stock-No
D-POWER

AUDI

A4 4 (8K2/8K5)

A4 3.0 V6 TDI	8K2, 8K5	3.0	176	6	04.08-	CCWA	4,4	Y609AS	5849	49
A4 3.0 V6 TDI (only for cyl. without pressure sensor)	8K2, 8K5	3.0	180	6	11.11-	CKVB	4,4	Y1002AS	8888	57
A4 3.0 V6 TDI (only for cyl. without pressure sensor)	8K2, 8K5	3.0	180	6	11.11-	CKVC	4,4	Y1002AS	8888	57

A5

A5 2.0 TDI	8TA	2.0	100	4	09.09-	CAGB	4,4	Y1002AS	8888	57
A5 2.0 TDI	8TA	2.0	100	4	09.09-	CJCB	4,4	Y1002AS	8888	57
A5 2.0 TDI	8TA	2.0	105	4	09.09-05.13	CMFA	4,4	Y1002AS	8888	57
A5 2.0 TDI	8T3, 8F7	2.0	105	4	09.09-	CAGA	4,4	Y609AS	5849	49
A5 2.0 TDI	8T3, 8F7	2.0	105	4	05.10-	CMEA	4,4	Y1002AS	8888	57
A5 2.0 TDI (only for cyl. without pressure sensor)	8TA	2.0	110	4	05.13-	CMFB	4,4	Y1002AS	8888	57
A5 2.0 TDI	8T3, 8F7, 8TA	2.0	120	4	08.08-	CAHB	4,4	Y1002AS	8888	57
A5 2.0 TDI	8T3, 8F7, 8TA	2.0	120	4	08.08-	CGLD	4,4	Y1002AS	8888	57
A5 2.0 TDI	8T3, 8F7, 8TA	2.0	120	4	09.09-	CNHC	4,4	Y1002AS	8888	57
A5 2.0 TDI	8T3, 8F7, 8TA	2.0	125	4	08.08-03.12	CAHA	4,4	Y609AS	5849	49
A5 2.0 TDI	8T3, 8F7, 8TA	2.0	130	4	10.11-	CGLC	4,4	Y1002AS	8888	57
A5 2.0 TDI (only for cyl. without pressure sensor)	8T3, 8F7, 8TA	2.0	140	4	09.13-	CNHA	4,4	Y1002AS	8888	57
A5 2.7 V6 TDI	8T3, 8F7, 8TA	2.7	120	6	09.07-05.08	CAMB	4,4	Y609AS	5849	49
A5 2.7 V6 TDI	8T3, 8F7, 8TA	2.7	120	6	05.08-03.12	CGKB	4,4	Y609AS	5849	49
A5 2.7 V6 TDI	8T3, 8F7, 8TA	2.7	140	6	07.07-05.08	CAMA	4,4	Y609AS	5849	49
A5 2.7 V6 TDI	8T3, 8F7, 8TA	2.7	140	6	05.08-03.12	CGKA	4,4	Y609AS	5849	49
A5 3.0 V6 TDI	8T3, 8F7, 8TA	3.0	150	6	09.11-	CLAB	4,4	Y1002AS	8888	57
A5 3.0 V6 TDI	8T3, 8F7, 8TA	3.0	155	6	03.08-05.10	CCWB	4,4	Y609AS	5849	49
A5 3.0 V6 TDI	8T3	3.0	176	6	06.07-05.08	CAPA	4,4	Y609AS	5849	49
A5 3.0 V6 TDI	8T3, 8F7, 8TA	3.0	176	6	03.08-02.12	CCWA	4,4	Y609AS	5849	49
A5 3.0 V6 TDI (only for cyl. without pressure sensor)	8T3, 8F7, 8TA	3.0	180	6	09.11-	CDUC	4,4	Y1002AS	8888	57
A5 3.0 V6 TDI (only for cyl. without pressure sensor)	8T3, 8TA	3.0	180	6	09.11-	CKVB	4,4	Y1002AS	8888	57
A5 2.0 TDI (only for cyl. without pressure sensor)	8F7, 8TA	2.0	105	4	09.09-	CJCA	4,4	Y1002AS	8888	57
A5 2.0 TDI (only for cyl. without pressure sensor)	8F7, 8TA	2.0	110	4	05.13-	CJCD	4,4	Y1002AS	8888	57

A6 1 (4A/C4)

A6 1.9 TDI	4A, C4	1.9	66	4	07.94-06.96	1Z	12,0	Y-732J	5605	4
A6 1.9 TDI	4A, C4	1.9	66	4	07.96-10.97	AHU	12,0	Y-732J	5605	4
A6 2.5 TDI	4A, C4	2.5	85	5	06.94-10.97	AAT	12,0	Y-732J	5605	4
A6 2.5 TDI	4A, C4	2.5	103	5	10.94-10.97	AEL	12,0	Y-732J	5605	4

A6 2 (4B/C5)

A6 1.9 TDI	4B, C5	1.9	81	4	04.97-04.01	AFN	12,0	Y-732J	5605	4
A6 1.9 TDI	4B, C5	1.9	81	4	08.99-10.00	AVG	12,0	Y-732J	5605	4
A6 1.9 TDI	4B, C5	1.9	85	4	11.00-04.01	AJM	11,0	Y-741U	6943	20
A6 1.9 TDI	4B, C5	1.9	96	4	06.01-01.05	AVF	12,0	Y-732J	5605	4
A6 1.9 TDI	4B, C5	1.9	96	4	06.01-01.05	AWX	11,0	Y-741U	6943	20
A6 2.5 TDI	4B, C5	2.5	110	6	04.97-05.00	AFB	11,0	Y-501U	4187	31
A6 2.5 TDI	4B, C5	2.5	110	6	10.98-05.01	AKN	11,0	Y-501U	4187	31
A6 2.5 TDI	4B, C5	2.5	114	6	06.01-06.02	AYM	11,0	Y-501U	4187	31
A6 2.5 TDI	4B, C5	2.5	120	6	07.02-08.03	BFC	11,0	Y-501U	4187	31





l kW C
y
i



Stock-No
D-POWER

AUDI

A6 2 (4B/C5)

A6 2.5 TDI	4B, C5	2.5	120	6	02.03-08.05	BCZ	11,0	Y-501U	4187	31
A6 2.5 TDI	4B, C5	2.5	120	6	02.03-01.05	BDG	11,0	Y-501U	4187	31
A6 2.5 TDI	4B, C5	2.5	132	6	11.99-08.03	AKE	11,0	Y-501U	4187	31
A6 2.5 TDI	4B, C5	2.5	132	6	02.03-08.05	BAU	11,0	Y-501U	4187	31
A6 2.5 TDI	4B, C5	2.5	132	6	02.03-01.05	BDH	11,0	Y-501U	4187	31

A6 3 (4F2/4F5)

A6 2.0 TDI	4F2, 4F5	2.0	89	4	09.05-06.06	BVG	7,0	CZ304	9864	55
A6 2.0 TDI	4F2, 4F5	2.0	100	4	07.04-11.05	BNA	4,4	YE14	7768	48
A6 2.0 TDI	4F2, 4F5	2.0	100	4	09.05-	BRF	7,0	CZ304	9864	55
A6 2.0 TDI	4F2, 4F5	2.0	100	4	10.08-	CAGB	4,4	Y-609AS	5849	49
A6 2.0 TDI	4F2, 4F5	2.0	103	4	07.04-11.05	BLB	4,4	YE14	7768	48
A6 2.0 TDI	4F2, 4F5	2.0	103	4	09.05-10.08	BRE	7,0	CZ304	9864	55
A6 2.0 TDI	4F2, 4F5	2.0	120	4	04.09-	CAHB	4,4	Y-609AS	5849	49
A6 2.0 TDI	4F2, 4F5	2.0	125	4	11.08-	CAHA	4,4	Y-609AS	5849	49
A6 2.7 TDI	4F2, 4F5	2.7	120	6	06.05-	BSG	4,4	Y-609AS	5849	49
A6 2.7 TDI	4F2, 4F5	2.7	120	6	10.08-	CANB	4,4	Y-609AS	5849	49
A6 2.7 TDI	4F2, 4F5	2.7	120	6	10.08-	CAND	4,4	Y-609AS	5849	49
A6 2.7 TDI	4F2, 4F5	2.7	132	6	11.04-10.08	BPP	4,4	Y-609AS	5849	49
A6 2.7 TDI	4F2, 4F5	2.7	140	6	10.08-	CANA	4,4	Y-609AS	5849	49
A6 2.7 TDI quattro	4F2, 4F5	2.7	140	6	10.08-	CANC	4,4	Y-609AS	5849	49
A6 3.0 TDI	4F2, 4F5	3.0	155	6	03.05-10.08	BNG	4,4	Y-609AS	5849	49
A6 3.0 TDI	4F2, 4F5	3.0	155	6	10.08-	CDYB	4,4	Y-609AS	5849	49
A6 3.0 TDI quattro	4F2, 4F5	3.0	165	6	04.04-05.06	BMK	4,4	Y-609AS	5849	49
A6 3.0 TDI quattro	4F2, 4F5	3.0	171	6	05.06-10.08	ASB	4,4	Y-609AS	5849	49
A6 3.0 TDI quattro	4F2, 4F5	3.0	176	6	10.08-	CDYA	4,4	Y-609AS	5849	49
A6 3.0 TDI quattro	4F2, 4F5	3.0	176	6	10.08-	CDYC	4,4	Y-609AS	5849	49

A6 4 (4G2/4G5)

A6 2.0 TDI	4G2, 4G5	2.0	100	4	01.12-	CGLF	4,4	Y1002AS	8888	57
A6 2.0 TDI	4G2, 4G5	2.0	120	4	03.11-	CGLD	4,4	Y1002AS	8888	57
A6 2.0 TDI	4G2, 4G5	2.0	130	4	04.11-	CGLC	4,4	Y1002AS	8888	57
A6 2.0 TDI	4G2, 4G5	2.0	130	4	04.11-	CMGB	4,4	Y1002AS	8888	57
A6 2.0 TDI (only for cyl. without pressure sensor)	4G2, 4G5	2.0	140	4	11.13-	CNHA	4,4	Y1002AS	8888	57
A6 3.0 V6 TDI	4G2, 4G5	3.0	150	6	04.11-	CLAA	4,4	Y1002AS	8888	57
A6 3.0 V6 TDI	4G2, 4G5	3.0	150	6	04.11-	CLAB	4,4	Y1002AS	8888	57
A6 3.0 V6 TDI (only for cyl. without pressure sensor)	4G2, 4G5	3.0	176	6	05.13-	CPNB	4,4	Y1002AS	8888	57
A6 3.0 V6 TDI	4G2, 4G5	3.0	180	6	04.11-	CDUC	4,4	Y1002AS	8888	57
A6 3.0 V6 TDI (only for cyl. without pressure sensor)	4G2, 4G5	3.0	180	6	04.11-	CDUD	4,4	Y1002AS	8888	57
A6 3.0 V6 TDI quattro (only for cyl. without pressure sensor)	4G2, 4G5	3.0	180	6	04.11-	CKVB	4,4	Y1002AS	8888	57
A6 3.0 V6 TDI quattro (only for cyl. without pressure sensor)	4G2, 4G5	3.0	180	6	01.12-	CKVC	4,4	Y1002AS	8888	57
A6 3.0 V6 TDI quattro	4G2, 4G5	3.0	230	6	11.11-	CGQB	4,4	Y1002AS	8888	57

A7 (4GA)

A7 Sportback 3.0 TDI	4GA	3.0	150	6	11.10-	CLAB	4,4	Y1002AS	8888	57
A7 Sportback 3.0 TDI	4GA	3.0	150	6	12.10-	CLAA	4,4	Y1002AS	8888	57
A7 Sportback 3.0 TDI	4GA	3.0	155	6	07.14-	CRTF	4,4	Y1002AS	8888	57





e kW
C
y
l



Stock-No
D-POWER™

AUDI

A7 (4GA)

A7 Sportback 3.0 TDI	4GA	3.0	155	6	07.14-	CTCB	4,4	Y1002AS	8888	57
A7 Sportback 3.0 TDI	4GA	3.0	160	6	07.14-	CRTE	4,4	Y1002AS	8888	57
A7 Sportback 3.0 TDI	4GA	3.0	160	6	07.14-	CTCC	4,4	Y1002AS	8888	57
A7 Sportback 3.0 TDI (only for cyl. without pressure sensor)	4GA	3.0	176	6	05.13-	CPNB	4,4	Y1002AS	8888	57
A7 Sportback 3.0 TDI	4GA	3.0	180	6	07.10-	CDUC	4,4	Y1002AS	8888	57
A7 Sportback 3.0 TDI	4GA	3.0	180	6	07.10-	CDUD	4,4	Y1002AS	8888	57
A7 Sportback 3.0 TDI (only for cyl. without pressure sensor)	4GA	3.0	180	6	07.10-	CKVB	4,4	Y1002AS	8888	57
A7 Sportback 3.0 TDI (only for cyl. without pressure sensor)	4GA	3.0	180	6	07.10-	CKVC	4,4	Y1002AS	8888	57
A7 Sportback 3.0 TDI quattro	4GA	3.0	200	6	05.14-	CRTD	4,4	Y1002AS	8888	57
A7 Sportback 3.0 TDI	4GA	3.0	230	6	11.11-	CGQB	4,4	Y1002AS	8888	57
A7 Sportback 3.0 TDI quattro	4GA	3.0	235	6	05.14-	CVUA	4,4	Y1002AS	8888	57
A7 Sportback 3.0 TDI quattro	4GA	3.0	240	6	09.14-	CVUB	4,4	Y1002AS	8888	57

A8 1 (4D2)

A8 2.5 TDI	4D2	2.5	110	6	06.97-04.00	AFB	11,0	Y-501U	4187	31
A8 2.5 TDI	4D2	2.5	110	6	11.97-09.02	AKN	11,0	Y-501U	4187	31
A8 2.5 TDI	4D2	2.5	132	6	11.99-09.02	AKE	11,0	Y-501U	4187	31
A8 3.3 TDI	4D2	3.3	165	8	12.99-09.02	AKF	11,0	Y-501U	4187	31

A8 2 (4E)

A8 3.0 TDI (VIN 4E-5-003 301→)	4E	3.0	155	6	11.03-07.10	BNG	4,4	Y-609AS	5849	49
A8 3.0 TDI (VIN 4E-5-003 301→)	4E	3.0	171	6	01.04-07.10	ASB	4,4	Y-609AS	5849	49
A8 4.0 TDI quattro	4E	4.0	202	8	05.03-07.05	ASE	11,0	Y-501U	4187	31
A8 4.2 TDI quattro	4E	4.2	235	8	01.05-06.05	BMC	4,4	Y-609AS	5849	49
A8 4.2 TDI quattro	4E	4.2	240	8	07.05-07.10	BVN	4,4	Y-609AS	5849	49

A8 3 (4H)

A8 3.0 TDI quattro	4H	3.0	155	6	08.10-	CDTB	4,4	Y1002AS	8888	57
A8 3.0 TDI quattro (only for cyl. without pressure sensor)	4H	3.0	176	6	11.12-	CPNA	4,4	Y1002AS	8888	57
A8 3.0 TDI quattro	4H	3.0	184	6	07.10-	CDTA	4,4	Y1002AS	8888	57
A8 3.0 TDI quattro	4H	3.0	184	6	07.10-	CMHA	4,4	Y1002AS	8888	57
A8 3.0 TDI quattro	4H	3.0	190	6	10.13-	CTBA	4,4	Y1002AS	8888	57
A8 4.2 TDI quattro	4H	4.2	258	8	11.09-	CDSB	4,4	Y1002AS	8888	57
A8 4.2 TDI quattro	4H	4.2	283	8	09.13-	CTEC	4,4	Y1002AS	8888	57

CABRIO

Cabriolet 1.9 TDi (color code: Black)	8G7	1.9	66	4	05.95-08.00	1Z	12,0	Y-918J	6285	2
Cabriolet 1.9 TDi (color code: Black)	8G7	1.9	66	4	05.95-08.00	AHU	12,0	Y-918J	6285	2
Cabrio 1.9		1.9	66	4	07.95-07.96	1Z	12,0	Y-732J	5605	4
Cabrio 1.9		1.9	66	4	07.96-08.00	AHU	12,0	Y-732J	5605	4

Q3 (8UB)

Q3 2.0 TDI	8UB	2.0	100	4	09.11-	CFFA	4,4	Y1002AS	8888	57
Q3 2.0 TDI	8UB	2.0	103	4	09.11-	CFFB	4,4	Y1002AS	8888	57
Q3 2.0 TDI	8UB	2.0	120	4	06.11-	CFGD	4,4	Y1002AS	8888	57
Q3 2.0 TDI	8UB	2.0	130	4	06.11-	CFGC	4,4	Y1002AS	8888	57
Q3 2.0 TDI	8UB	2.0	130	4	06.11-	CLLB	4,4	Y1002AS	8888	57

Q5 (8R)

Q5 2.0 TDI	8R	2.0	100	4	08.09-	CAGB	4,4	Y-609AS	5849	49
------------	----	-----	-----	---	--------	------	-----	---------	------	----





e kW C
y
i



Stock-No
D-POWER

AUDI

Q5 (8R)

Q5 2.0 TDI	8R	2.0	100	4	05.10-	CJCB		4,4	Y1002AS	8888	57
Q5 2.0 TDI	8R	2.0	105	4	08.09-	CAGA		4,4	Y-609AS	5849	49
Q5 2.0 TDI	8R	2.0	105	4	05.10-	CJCA		4,4	Y1002AS	8888	57
Q5 2.0 TDI (only for cyl. without pressure sensor)	8R	2.0	110	4	05.13-	CJCD		4,4	Y1002AS	8888	57
Q5 2.0 TDI	8R	2.0	120	4	11.08-09.10	CAHB		4,4	Y-609AS	5849	49
Q5 2.0 TDI	8R	2.0	120	4	05.10-	CGLA		4,4	Y1002AS	8888	57
Q5 2.0 TDI	8R	2.0	125	4	11.08-09.10	CAHA		4,4	Y-609AS	5849	49
Q5 2.0 TDI	8R	2.0	125	4	05.10-09.12	CGLB		4,4	Y1002AS	8888	57
Q5 2.0 TDI	8R	2.0	125	4	11.10-09.12	CMGA		4,4	Y1002AS	8888	57
Q5 2.0 TDI	8R	2.0	130	4	07.12-	CGLC		4,4	Y1002AS	8888	57
Q5 2.0 TDI	8R	2.0	130	4	07.12-	CMGB		4,4	Y1002AS	8888	57
Q5 2.0 TDI (only for cyl. without pressure sensor)	8R	2.0	140	4	11.13-	CNHA		4,4	Y1002AS	8888	57
Q5 3.0 V6 TDI	8R	3.0	155	6	11.08-09.12	CCWB		4,4	Y-609AS	5849	49
Q5 3.0 V6 TDI	8R	3.0	176	6	11.08-	CCWA		4,4	Y-609AS	5849	49
Q5 3.0 V6 TDI	8R	3.0	180	6	06.12-	CDUD		4,4	Y1002AS	8888	57
Q5 3.0 V6 TDI (only for cyl. without pressure sensor)	8R	3.0	190	6	06.12-	CTBA		4,4	Y1002AS	8888	57
Q5 3.0 V6 TDI SQ5 quattro (only for cyl. without pressure sensor)	8R	3.0	230	6	12.12-	CGQB		4,4	Y1002AS	8888	57

Q7 (4L)

Q7 3.0 TDI	4L	3.0	180	6	05.11-	CRCA		4,4	Y1002AS	8888	57
Q7 3.0 TDI (only for cyl. without pressure sensor)	4L	3.0	180	6	05.11-	CLZB		4,4	Y1002AS	8888	57
Q7 4.2 TDI	4L	4.2	230	8	03.07-06.09	BTR		4,4	Y-609AS	5849	49
Q7 4.2 TDI	4L	4.2	250	8	06.09-05.10	CCFA		4,4	Y1002AS	8888	57
Q7 4.2 TDI	4L	4.2	250	8	05.10-	CCFC		4,4	Y1002AS	8888	57
Q7 6.0 TDI	4L	6.0	368	12	09.08-	CCGA		4,4	Y-609AS	5849	49
Q7 3.0 TDI	4L	3.0	155	6	03.06-05.10	BUN		4,4	Y-609AS	5849	49
Q7 3.0 TDI	4L	3.0	155	6	11.07-05.10	CASB		4,4	Y-609AS	5849	49
Q7 3.0 TDI (only for cyl. without pressure sensor)	4L	3.0	165	6	06.09-05.12	CATA		4,4	Y1002AS	8888	57
Q7 3.0 TDI (VIN 4L-7-036115→)	4L	3.0	171	6	03.06-05.08	BUG		4,4	Y-609AS	5849	49
Q7 3.0 TDI	4L	3.0	176	6	11.07-05.10	CASA		4,4	Y-609AS	5849	49
Q7 3.0 TDI	4L	3.0	180	6	05.11-	CJGD		4,4	Y1002AS	8888	57

TT (8J3/8J9)

TT 2.0 TDI quattro	8J3, 8J9	2.0	125	4	06.08-	CBBB		4,4	Y1002AS	8888	57
TT 2.0 TDI quattro	8J3, 8J9	2.0	125	4	06.08-06.10	CBBB		4,4	Y-609AS	5849	49
TT 2.0 TDI quattro	8J3, 8J9	2.0	125	4	05.10-	CFGB		4,4	Y1002AS	8888	57

TT (FV3/FV9)

TT 2.0 TDI (only for cyl. without pressure sensor)	FV3, FV9	2.0	135	4	07.14-	CUNA		4,4	Y1002AS	8888	57
--	----------	-----	-----	---	--------	------	--	-----	---------	------	----

AUSTIN

AUSTIN TAXI

Austin TAXI				4	08.83-			11,0	Y-208T	1250	
-------------	--	--	--	---	--------	--	--	------	--------	------	--

AVIA

A21

A21.1 D				4	10.90-			11,0	Y-208T	1250	
---------	--	--	--	---	--------	--	--	------	--------	------	--



e kW C
y iStock-No
D-POWER**BMW****1 (SERIES) E87**

118d 2.0	E87	2.0	90	4	11.03-09.12	M47 N204D4	5,0	Y-547AS	5968	47
118d 2.0	E87	2.0	105	4	11.03-09.12	M47 D20A	5,0	Y-547AS	5968	47
120d 2.0	E87	2.0	120	4	09.04-	M47 N204D4	5,0	Y-547AS	5968	47
120d 2.0	E87	2.0	130	4	11.03-09.12	M47 D20	5,0	Y-547AS	5968	47

3 (SERIES) E30

324d 2.4	E30	2.4	63	6	09.85-08.91	M21 D24	11,0	Y-924J	7906	1
324Td 2.4	E30	2.4	85	6	09.87-12.93	M21 D24	11,0	Y-924J	7906	1

3 (SERIES) E36

318Tds 1.8	E36	1.8	66	4	11.94-02.98	M41 D18	11,0	Y-924J	7906	1
325Td 2.5	E36	2.5	85	6	01.91-02.98	M51 D25	11,0	Y-924J	7906	1
325Tds 2.5	E36	2.5	105	6	06.93-05.99	M51 D25	11,0	Y-924J	7906	1

3 (SERIES) E46

318d 2.0	E46/ 4	2.0	85	4	09.01-11.03	M47 D20	11,0	Y-507J	2691	32
318d Touring 2.0	E46/ 3	2.0	85	4	09.01-11.03	M47 D20	11,0	Y-507J	2691	32
318d 2.0	E46/ 4	2.0	85	4	08.02-01.05	M47 N D20	5,0	Y-547AS	5968	47
318d Touring 2.0	E46/ 3	2.0	85	4	08.02-07.05	M47 N D20	5,0	Y-547AS	5968	47
318td Compact 2.0	E46	2.0	85	4	08.02-12.04	M47 N D20	5,0	Y-547AS	5968	47
320Cd 2.0	E46/ 2	2.0	110	4	03.03-05.06	M47 N D20	5,0	Y-547AS	5968	47
320Cd 2.0	E46/ C	2.0	110	4	06.04-08.06	M47 N D20	5,0	Y-547AS	5968	47
320d 2.0	E46/ 4	2.0	100	4	07.97-08.01	M47 D20	11,0	Y-507J	2691	32
320d Touring 2.0	E46/ 3	2.0	100	4	02.99-08.01	M47 D20	11,0	Y-507J	2691	32
320d Touring 2.0	E46/ 3	2.0	110	4	06.99-07.05	M47 N D20	5,0	Y-547AS	5968	47
320d 2.0	E46/ 4	2.0	110	4	10.00-01.05	M47 N D20	5,0	Y-547AS	5968	47
320td Compact 2.0	E46/ 5	2.0	110	4	05.00-12.04	M47 N D20	5,0	Y-547AS	5968	47
330Cd Coupe 3.0	E46/ 2	3.0	150	6	08.02-05.06	M57 N D30	5,0	Y-547AS	5968	47
330Cd Cabrio 3.0	E46/ C	3.0	150	6	11.04-08.06	M57 N D30	5,0	Y-547AS	5968	47
330d Touring 3.0	E46/ 3	3.0	135	6	06.98-03.03	M57 D30	11,0	Y-507J	2691	32
330d 3.0	E46/ 4	3.0	135	6	09.00-11.03	M57 D30	11,0	Y-507J	2691	32
330d Touring 3.0	E46/ 3	3.0	150	6	09.02-07.05	M57 N D30	5,0	Y-547AS	5968	47
330d 3.0	E46/ 4	3.0	150	6	03.03-02.05	M57 N D30	5,0	Y-547AS	5968	47
330Xd 3.0	E46/ 4	3.0	135	6	01.00-02.03	M57 D30	11,0	Y-507J	2691	32
330Xd Touring 3.0	E46/ 3	3.0	135	6	01.00-03.03	M57 D30	11,0	Y-507J	2691	32
330Xd Touring 3.0	E46/ 3	3.0	150	6	08.02-05.05	M57 N D30	5,0	Y-547AS	5968	47
330Xd 3.0	E46/ 4	3.0	150	6	09.02-12.04	M57 N D30	5,0	Y-547AS	5968	47

3 (SERIES) E90

318d 2.0	E90	2.0	90	4	09.05-09.07	M47 N204D4	5,0	Y-547AS	5968	47
320d 2.0	E90	2.0	120	4	03.05-05.07	M47 N204D4	5,0	Y-547AS	5968	47
325d 3.0	E90	3.0	145	6	03.06-	M57 N2 D30	5,0	Y-547AS	5968	47
330d 3.0	E90	3.0	170	6	01.06-	M57 N2 D30	5,0	Y-547AS	5968	47
330d 3.0	E90	3.0	180	6	01.09-12.11	M57 N2 306 D3	5,0	Y-547AS	5968	47
335d 3.0	E90	3.0	210	6	09.06-	M57 N2 D30	5,0	Y-547AS	5968	47

3 (SERIES) E91

318d Touring 2.0	E91	2.0	90	4	09.05-09.07	M47 N204D4	5,0	Y-547AS	5968	47
320d Touring 2.0	E91	2.0	120	4	09.05-11.07	M47 N204D4	5,0	Y-547AS	5968	47
325d Touring 3.0	E91	3.0	145	6	03.06-	M57 N2 D30	5,0	Y-547AS	5968	47





€ kW C
Y
I



Stock-No
D-POWER

BMW

3 (SERIES) E91

330d Touring 3.0	E91	3.0	170	6	09.05-	M57 N2 D30	5,0	Y-547AS	5968	47
335d Touring 3.0	E91	3.0	210	6	09.06-	M57 N2 D30	5,0	Y-547AS	5968	47

3 (SERIES) E92

325d Coupe 3.0	E92	3.0	145	6	03.06-	M57 N2 D30	5,0	Y-547AS	5968	47
330Cd 3.0	E92	3.0	170	6	09.06-	M57 N2 D30	5,0	Y-547AS	5968	47
335d Coupe 3.0	E92	3.0	210	6	09.06-	M57 N2 D30	5,0	Y-547AS	5968	47

3 (SERIES) E93

330d Cabrio 3.0	E93	3.0	170	6	04.07-	M57 N2 D30	5,0	Y-547AS	5968	47
-----------------	-----	-----	-----	---	--------	------------	-----	---------	------	----

5 (SERIES) E34

524Td 2.4	E34	2.4	85	6	03.88-08.91	M21 D24	11,0	Y-924J	7906	1
525Td 2.5	E34	2.5	85	6	06.92-06.96	M51 D25	11,0	Y-924J	7906	1
525Tds 2.5	E34	2.5	105	6	01.90-06.96	M51 D25	11,0	Y-924J	7906	1

5 (SERIES) E39

520d 2.0	E39	2.0	100	4	09.99-08.03	M47 D20	11,0	Y-507J	2691	32
520d Touring 2.0	E39	2.0	100	4	09.99-08.03	M47 D20	11,0	Y-507J	2691	32
525d 2.5	E39	2.5	120	6	03.00-12.03	M57 D25	11,0	Y-507J	2691	32
525d Touring 2.5	E39	2.5	120	6	03.00-12.03	M57 D25	11,0	Y-507J	2691	32
525Tds 2.5	E39	2.5	105	6	03.95-10.00	M51 D25	11,0	Y-924J	7906	1
530d 3.0	E39	3.0	142	6	09.98-12.03	M57 D30	11,0	Y-507J	2691	32
530d Touring 3.0	E39	3.0	142	6	02.99-03.04	M57 D30	11,0	Y-507J	2691	32

5 (SERIES) E60

520d 2.0	E60	2.0	120	4	02.05-09.07	M47 N204D4	5,0	Y-547AS	5968	47
525d 2.5	E60	2.5	130	6	03.04-11.06	M57 N D25	5,0	Y-547AS	5968	47
525d 2.5	E60	2.5	145	6	12.06-	M57 N2 D25	5,0	Y-547AS	5968	47
530d 3.0	E60	3.0	155	6	07.03-03.10	M57 D30	5,0	Y-547AS	5968	47
530d 3.0	E60	3.0	160	6	08.02-10.05	M57 N D30	5,0	Y-547AS	5968	47
530d 3.0	E60	3.0	170	6	02.05-	M57 N2 D30	5,0	Y-547AS	5968	47
530d xDrive 3.0	E60	3.0	173	6	09.08-03.10	M57 D30	5,0	Y-547AS	5968	47
530Xd 3.0	E60	3.0	160	6	10.05-	M57 N D30	5,0	Y-547AS	5968	47
535d 3.0	E60	3.0	200	6	09.04-02.05	M57 N D30	5,0	Y-547AS	5968	47
535d 3.0	E60	3.0	210	6	09.05-	M57 N2 D30	5,0	Y-547AS	5968	47

5 (SERIES) E61

520d Touring	E61	2.0	120	4	11.05-	M47 N204D4	5,0	Y-547AS	5968	47
525d Touring 2.5	E61	2.5	130	6	05.04-	M57 N D25	5,0	Y-547AS	5968	47
530d Touring 3.0	E61	3.0	160	6	11.02-10.05	M57 N D30	5,0	Y-547AS	5968	47
530d Touring 3.0	E61	3.0	173	6	02.05-	M57 N2 D30	5,0	Y-547AS	5968	47
530d Touring LCI 3.0	E61	3.0	180	6	02.10-	M57 N2 D30	5,0	Y-547AS	5968	47
535d Touring 3.0	E61	3.0	200	6	09.04-	M57 N D30	5,0	Y-547AS	5968	47

6 (SERIES) E63

635Cd 3.0	E63	3.0	210	6	05.06-	M57 N2 D30	5,0	Y-547AS	5968	47
-----------	-----	-----	-----	---	--------	------------	-----	---------	------	----

7 (SERIES) E38

725Tds 2.5	E38	2.5	105	6	09.95-11.00	M51 D25	11,0	Y-924J	7906	1
730d 3.0	E38	3.0	142	6	09.98-12.01	M57 D30	11,0	Y-507J	2691	32

7 (SERIES) E65

730d 3.0	E65	3.0	150	6	11.01-02.05	M57 N D30	5,0	Y-547AS	5968	47
----------	-----	-----	-----	---	-------------	-----------	-----	---------	------	----





e kW C
y
i



Stock-No
D-POWER

BMW

7 (SERIES) E65

730d 3.0	E65	3.0	170	6	07.04-	M57 N2 D30	5,0	Y-547AS	5968	47
----------	-----	-----	-----	---	--------	------------	-----	---------	------	----

X3 (SERIES) E83

X3 xDrive 20d 2.0	E83	2.0	110	4	09.04-	M47 N D20	5,0	Y-547AS	5968	47
X3 xDrive 30d 3.0	E83	3.0	150	6	01.03-09.05	M57 N D30	5,0	Y-547AS	5968	47
X3 xDrive 30d 3.0	E83	3.0	155	6	09.08-	M57 D30	5,0	Y-547AS	5968	47
X3 xDrive 30d 3.0	E83	3.0	160	6	10.04-	M57 N2 D30	5,0	Y-547AS	5968	47
X3 xDrive 35d 3.0	E83	3.0	210	6	09.06-	M57 N2 D30	5,0	Y-547AS	5968	47

X5 (SERIES) E53

X5d 4x4 3.0	E53	3.0	142	6	08.01-11.03	M57 D30	11,0	Y-507J	2691	32
X5d 3.0	E53	3.0	155	6	08.04-	M57 D30	5,0	Y-547AS	5968	47
X5d 4x4 3.0	E53	3.0	160	6	01.03-09.06	M57 N D30	5,0	Y-547AS	5968	47

CHEVROLET

CAPTIVA

Captiva 2.0 D		2.0	110	4	10.06-	Z20S	4,4	Y8009AS	96478	
Captiva 2.0 TDCi	C140	2.0	120	4	01.11-	Z20D1	4,4	Y8010AS	93503	
Captiva 2.2 VCDi	C140	2.2	120	4	03.11-	Z22D1	4,4	Y8010AS	93503	
Captiva 2.2 VCDi	C140	2.2	135	4	01.08-	Z22D1	4,4	Y8010AS	93503	

CRUZE

Cruze 2.0 D	J300, J305	2.0	92	4	05.09-05.11	Z20S1	4,4	Y8009AS	96478	
Cruze 2.0 D	J300, J305	2.0	110	4	05.09-	Z20S1	4,4	Y8009AS	96478	
Cruze 2.0 TDCi	J300	2.0	120	4	08.10-	Z20D1	4,4	Y8010AS	93503	
Cruze 2.0 TDCi	J305	2.0	120	4	06.11-	Z20D1	4,4	Y8010AS	93503	
Cruze 2.0 TDCi/VCDi	J308	2.0	120	4	08.12-12.15	Z20D1	4,4	Y8010AS	93503	

EPICA

Epica 2.0 D		2.0	110	4	01.07-	Z20DMH	4,4	Y8009AS	96478	
-------------	--	-----	-----	---	--------	--------	-----	---------	-------	--

LACETTI

Lacetti 2.0 D		2.0	89	4	01.07-	Z20DM	4,4	Y8009AS	96478	
---------------	--	-----	----	---	--------	-------	-----	---------	-------	--

NUBIRA

Nubira 2.0 D		2.0	89	4	01.07-	Z20DM	4,4	Y8009AS	96478	
--------------	--	-----	----	---	--------	-------	-----	---------	-------	--

ORLANDO

Orlando 2.0	J309	2.0	96	4	02.11-12.15	Z20D1	4,4	Y8010AS	93503	
Orlando 2.0 TDCi	J309	2.0	120	4	02.11-	Z20D1	4,4	Y8010AS	93503	

TRAIL BLAZER

Trailblazer 2.8 CRDi	31UX	2.8	132	4	08.12-	LWH	4,4	Y8011AS	90403	
----------------------	------	-----	-----	---	--------	-----	-----	---------	-------	--

CHRYSLER

300 C

300 C 3.0 CRD		3.0	160	6	09.05-12.10	M664	4,4	Y8002AS	6287	51
---------------	--	-----	-----	---	-------------	------	-----	---------	------	----

PT

PT Cruiser 2.2 CRD		2.2	89	4	03.02-	EDJ	11,5	Y-745U	6346	11
PT Cruiser 2.2 CRD		2.2	110	4	08.05-		11,5	Y-745U	6346	11

SEBRING

Sebring 2.0 CRD		2.0	103	4	.07-	VW engine	5,0	Y-607AS	7560	50
-----------------	--	-----	-----	---	------	-----------	-----	---------	------	----

VOYAGER 2

Voyager 2		2.5	88	4	04.92-04.95	VM 425 CLIRE	11,0	Y-924J	7906	1
-----------	--	-----	----	---	-------------	--------------	------	--------	------	---





l kW C
y
i



Stock-No
D-POWER

CHRYSLER

VOYAGER 2

Voyager 2	2.5	88	4	04.92-04.95	VM HR-492	11,0	Y-924J	7906	1
Voyager 2	2.5	88	4	05.95-01.01	VM HR425 CLIEE	11,0	Y-741U	6943	20

VOYAGER 4

Voyager 4 2.5 CRD	RG	2.5	88	4	08.05-05.07	EDK, ENJ	11,0	Y1031J	95970	71
Voyager 4 2.5 CRD	RG	2.5	105	4	02.00-05.07	ENC	11,0	Y1031J	95970	71
Voyager 4 2.8 CRD	RG	2.8	110	4	06.04-02.08	ENR	11,0	Y1031J	95970	71
Grand Voyager 2.8 CRDi	RT	2.8	120	4	07.07-	ENS	4,4	Y8011AS	90403	

YPSILON

CHRYSLER Ypsilon 1.3 (For OE-No. 55238404)	312YXE1A	1.3	70	4	09.11-	199B1000	4,3	Y9001AS	97719	72
--	----------	-----	----	---	--------	----------	-----	---------	-------	----

CITROËN

AX

AX D	1.4	39	4	09.88-09.94	TUD 3 L	11,5	Y-910J	3617	3
AX D	1.5	40	4	10.94-12.99	TUD 5 VJZ	11,0	Y-503J	1009	10

BERLINGO

Berlingo Hdi	1.4	55	4	01.05-	DV4TD	11,0	YE04	1684	40	
Berlingo 1.6 Hdi 75	1.6	55	4	04.08-	DV6ETED, DV6ETEDM	5,0	Y8001AS	8904	58	
Berlingo 1.6 Hdi 75	1.6	55	4	04.08-	DV6BUTED4	11,0	YE05	91322	73	
Berlingo 1.6 Hdi	1.6	66	4	07.06-	DV6	11,0	YE04	1684	40	
Berlingo 1.6 Hdi 90	1.6	66	4	04.08-	DV6ATED4	11,0	YE05	91322	73	
Berlingo 1.6 Hdi 90	1.6	68	4	07.10-	DV6DTEED, DV6DTEEDM	5,0	Y8001AS	8904	58	
Berlingo 1.6 Hdi 110	1.6	80	4	04.08-	DV6TED4	11,0	YE05	91322	73	
Berlingo 1.6 Hdi 110	1.6	82	4	07.10-	DV6C	5,0	Y8001AS	8904	58	
Berlingo 1.6 Hdi 115	1.6	84	4	07.10-	DV6C	5,0	Y8001AS	8904	58	
Berlingo	1.8	43	4	07.96-08.98	XUD7 A9A	11,0	Y-924J	7906	1	
Berlingo	1.8	43	4	09.98-03.99	XUD7 A9A	11,0	Y-924J	7906	1	
Berlingo	1.8	51	4	09.98-03.99	DW8 WJZ	11,0	Y-503J	1009	10	
Berlingo	1.8	66	4	09.98-03.99	DW8TD	11,0	Y-503J	1009	10	
Berlingo	1.9	51	4	07.96-09.98	XUD9A D9B, DJY	11,0	Y-924J	7906	1	
Berlingo	GEWJYB, MEWJYF, MEWJZF	1.9	51	4	07.98-03.06	DW8B	11,0	Y-503J	1009	10
Berlingo	MBWJYB	1.9	51	4	07.98-03.06	DW8B	11,0	Y-503J	1009	10
Berlingo	GBWJYB, GCWJYB, MBWJYF, MBWJZF, MCWJYF, MCWJZF	1.9	51	4	09.98-05.08	DW8B	11,0	Y-503J	1009	10
Berlingo	GEWJYB9	1.9	51	4	11.02-03.06	DW8B	11,0	Y-503J	1009	10
Berlingo		1.9	52	4	09.98-12.02	XUD9A	11,0	Y-924J	7906	1
Berlingo HDI	2.0	66	4	10.99-	DW10TD	11,0	Y-504J	1441	24	
Berlingo 2.0 Hdi	2.0	81	4	05.02-10.06	DW10ATED4	11,0	Y1005J	7957	56	
Berlingo 2.0 Hdi	2.0	88	4	11.06-	DW10UTED4	11,0	Y1005J	7957	56	
Berlingo 2.0 Hdi	2.0	100	4	11.06-	DW10BTED4	11,0	Y1005J	7957	56	

BERLINGO FIRST

Berlingo	GBWJYB, GCWJYB	1.9	51	4	06.08-12.11	DW8B	11,0	Y-503J	1009	10
Berlingo	GJWJYB	1.9	51	4	06.08-12.11	DW8B	11,0	Y-503J	1009	10





e kW C
y
i



Stock-No
P-POWER™

CITROËN

BERLINGO MULTISPACE

Berlingo	7J9HN6, 7J9HN8, 7JBHW6	1.6	55	4	04.08-	DV6ETED	5,0	Y8001AS	8904	58
Berlingo	GJ9HXC	1.6	66	4	07.05-05.08	DV6ATED4	11,0	YE05	91322	73
Berlingo	7J9HVB, 7J9HXB	1.6	66	4	04.08-	DV6ATED4	11,0	YE05	91322	73
Berlingo	7J9H06, 7J9H08, 7J9HP6, 7J9HP8	1.6	68	4	07.10-	DV6DTED	5,0	Y8001AS	8904	58
Berlingo	7J9HX8	1.6	68	4	07.10-	DV6ATED4	11,0	YE05	91322	73
Berlingo	7J9HR6	1.6	82	4	07.10-	DV6C	5,0	Y8001AS	8904	58
Berlingo	7J9HR6	1.6	84	4	07.10-	DV6C	5,0	Y8001AS	8904	58
Berlingo Multispace		1.9	51	4	01.97-09.98	XUD9A D9B, DJY	11,0	Y-924J	7906	1
Berlingo	GJWJYB, MFWJYFA, MFWJZFA	1.9	51	4	07.98-10.05	DW8B	11,0	Y-503J	1009	10
Berlingo	MFWJYF, MFWJYFA, MFWJZF, MFWJZFA	1.9	51	4	07.98-10.02	DW8B	11,0	Y-503J	1009	10
Berlingo Multispace		1.9	51	4	09.98-12.02	DW8 WJZ	11,0	Y-503J	1009	10
Berlingo Multispace Hdi		2.0	66	4	10.99-	DW10TD	11,0	Y-504J	1441	24

BX

BX 17 D		1.8	44	4	07.85-01.93	XUD 7	11,0	Y-924J	7906	1
BX 17 TD, TRD		1.8	66	4	03.88-01.93	XUD 7 TE	11,0	Y-924J	7906	1
BX 19 D, TD, TRD		1.9	51	4	03.87-	XUD 9 A, L	11,0	Y-924J	7906	1

C1 I

C1 I 1.4 Hdi		1.4	40	4	05.06-	DV4	11,0	YE04	1684	40
C1 I 1.4 Hdi		1.4	50	4	06.05-	DV4TD	11,0	YE05	91322	73

C15

C15 D		1.8	44	4	10.84-05.95	XUD7	11,0	Y-924J	7906	1
C15 D		1.8	44	4	06.95-	XUD7	11,0	Y-924J	7906	1
C15 D		1.9	44	4	12.00-	DW8	11,0	Y-503J	1009	10

C2

C2 Hdi		1.4	51	4	12.04-	DV4TD	11,0	YE05	91322	73
C2 Phase 2		1.6	80	4	05.08-	DV6TED4	11,0	YE05	91322	73

C25

C25 D		1.9	51	4	07.87-01.94	D9B	11,0	Y-924J	7906	1
C25 D		2.5	54	4	07.81-01.94	CRD93	11,0	Y-208T	1250	
C25 TD		2.5	70	4	08.87-01.94	CRD93LS	11,0	Y-208T	1250	

C3

C3 Hdi		1.4	51	4	12.04-	DV4TD	11,0	YE05	91322	73
C3 Hdi		1.4	52	4	03.02-12.04	DV4TD	11,0	YE04	1684	40
C3 Hdi 16V		1.4	68	4	03.02-12.04	DV4TED4	11,0	YE04	1684	40
C3 Hdi		1.4	68	4	12.04-08.05	DV4TED4	11,0	YE05	91322	73
C3		1.6	66	4	10.05-	DV6TED4	11,0	YE05	91322	73
C3 1.6 e-HDi/HDi	SC9HP0, SC9HP4	1.6	68	4	11.09-	DV6DTEDM	5,0	Y8001AS	8904	58
C3 Hdi		1.6	81	4	03.06-	DV4TED6	11,0	YE05	91322	73

C3 II

C3 II 1.4 Hdi 70		1.4	50	4	11.09-	DV4C, DV4TD	11,0	YE05	91322	73
------------------	--	-----	----	---	--------	-------------	------	------	-------	----





l kW C
y
i



Stock-No
D-POWER

CITROËN

C3 II

C3 1.6 BlueHdi/HDi	SC9HKC, SCBHW6	1.6	55	4	10.14-	DV6ETEDM	5,0	Y8001AS	8904	58
C3 II 1.6 Hdi 90		1.6	66	4	11.09-	DV6ATED4	11,0	YE05	91322	73
C3 II 1.6 Hdi		1.6	68	4	11.09-	DV6DTED	5,0	Y8001AS	8904	58
C3 II 1.6 Hdi 110		1.6	82	4	11.09-	DV6CTED4	5,0	Y8001AS	8904	58
C3 II 1.6 Hdi 115		1.6	84	4	09.12-	DV6C	5,0	Y8001AS	8904	58

C3 PICASSO

C3 Picasso 1.6 Hdi 90		1.6	66	4	12.08-	DV6ATED4	11,0	YE05	91322	73
C3 Picasso 1.6 HDi	SH9HXC	1.6	66	4	02.09-	DV6ATED4	11,0	YE05	91322	73
C3 Picasso 1.6 Hdi 90		1.6	68	4	07.10-	DV6DTED	5,0	Y8001AS	8904	58
C3 Picasso 1.6 e-HDi/HDi	SH9HP0, SH9HP8, SH9HPC	1.6	68	4	07.10-	DV6DTED	5,0	Y8001AS	8904	58
C3 Picasso 1.6 Hdi 110		1.6	80	4	12.08-	DV6TED4	11,0	YE05	91322	73
C3 Picasso 1.6 Hdi 110		1.6	82	4	07.10-	DV6C	5,0	Y8001AS	8904	58
C3 Picasso 1.6 HDi	SH9HR8	1.6	82	4	09.10-	DV6C	5,0	Y8001AS	8904	58
C3 Picasso 1.6 Hdi 115		1.6	84	4	01.13-	DV6C	5,0	Y8001AS	8904	58
C3 Picasso 1.6 HDi	SH9HD8	1.6	84	4	01.13-	DV6C	5,0	Y8001AS	8904	58

C4

C4 1.6 HDi	LC9HVB, LC9HVH, LC9HXB, LC9HXH	1.6	66	4	09.04-07.11	DV6ATED4	11,0	YE05	91322	73
C4 Coupe Hdi		1.6	68	4	12.04-		11,0	YE04	1684	40
C4 1.6 HDi	NC9HP0	1.6	68	4	11.09-	DV6DTED	5,0	Y8001AS	8904	58
C4 1.6 HDi	NC9HP0	1.6	68	4	11.09-	DV6DTEDM	5,0	Y8001AS	8904	58
C4 1.6 HDi	NR9HP0	1.6	68	4	06.10-	DV6DTED	5,0	Y8001AS	8904	58
C4 1.6 HDi	NR9HP0	1.6	68	4	06.10-	DV6DTEDM	5,0	Y8001AS	8904	58
C4 Coupe Hdi		1.6	80	4	12.04-06.06	DV6TED4	11,0	YE04	1684	40
C4 1.6 e-HDi/HDi	NC9HR8, NC9HRA	1.6	82	4	11.09-	DV6C	5,0	Y8001AS	8904	58
C4 1.6 HDi	NC9HR8	1.6	82	4	11.09-	DV6C	5,0	Y8001AS	8904	58
C4 1.6 e-HDi/HDi	NC90R8, NC9HR8, NC9HRA	1.6	84	4	07.12-	DV6C	5,0	Y8001AS	8904	58
C4 1.6 BlueHdi/e-HDi	NC9HDA, NCBHZM	1.6	85	4	01.13-	DV6C	5,0	Y8001AS	8904	58
C4 Hdi		2.0	100	4	09.04-	DW10BTED4	11,0	Y1005J	7957	56
C4 2.0 HDI FAP		2.0	100	4	03.07-	DW10BTED4	11,0	Y-504J	1441	24
C4 2.0 Hdi		2.0	103	4	07.08-	DW10BTED4	11,0	Y1005J	7957	56
C4 2.0 HDi	LCRHZD	2.0	81	4	04.07-07.08	DW10ATED	11,0	Y-504J	1441	24

C4 AIRCROSS

C4 Aircross 1.6 Hdi 115		1.6	84	4	04.12-	DV6C	5,0	Y8001AS	8904	58
-------------------------	--	-----	----	---	--------	------	-----	---------	------	----

C4 GRAND PICASSO

C4 Grand Picasso 1.6 e-HDi	DA9HPT, DE9HPT	1.6	68	4	08.13-	DV6DTED	5,0	Y8001AS	8904	58
C4 Grand Picasso 1.6 Hdi 110		1.6	80	4	09.06-	DV6TED4	11,0	YE05	91322	73
C4 Grand Picasso 1.6 Hdi 110		1.6	82	4	09.10-	DV6C	5,0	Y8001AS	8904	58
C4 Grand Picasso 2.0 Hdi		2.0	100	4	02.07-	DW10BTED4	11,0	Y1005J	7957	56
C4 Grand Picasso 2.0 Hdi		2.0	102	4	09.06-	DW10TD	11,0	Y-504J	1441	24
C4 Grand Picasso 2.0 Hdi 150		2.0	110	4	06.09-	DW10CTED4	5,0	Y8001AS	8904	58
C4 Grand Picasso 2.0 Hdi 165		2.0	120	4	11.10-	DW10CTED4	5,0	Y8001AS	8904	58





e kW C
y I



Stock-No
P-POWER™

CITROËN

C4 II

C4 II 1.6 HDi 90	1.6	68	4	11.09-	DV6DTEd, DV6DTEdM	5,0	Y8001AS	8904	58
C4 II 1.6 HDi 110	1.6	82	4	11.09-	DV6C	5,0	Y8001AS	8904	58
C4 II 1.6 e-HDi 115	1.6	84	4	07.12-	DV6C	5,0	Y8001AS	8904	58
C4 II 2.0 Hdi 150	2.0	110	4	11.09-	DW10CTED4	5,0	Y8001AS	8904	58

C4 PICASSO

C4 Picasso 1.6 e-HDi/HDi	DD9HP0, DD9HPT	1.6	68	4	02.13-	DV6DTEd	5,0	Y8001AS	8904	58
C4 Picasso 1.6 Hdi		1.6	81	4	02.07-	DV6TED4	11,0	YE05	91322	73
C4 Picasso 1.6 Hdi		1.6	81	4	03.07-	DV6TED	11,0	YE05	91322	73
C4 Picasso 1.6 Hdi 110		1.6	82	4	09.10-	DV6C	5,0	Y8001AS	8904	58
C4 Picasso 1.6 Hdi		1.6		4	12.08-	DV6	11,0	YE05	91322	73
C4 Picasso 2.0 Hdi		2.0	100	4	10.06-	DW10BTED4	11,0	Y1005J	7957	56
C4 Picasso 2.0 Hdi		2.0	102	4	02.07-	DW10TD	11,0	Y-504J	1441	24
C4 Picasso 2.0 Hdi 150		2.0	110	4	06.09-	DW10CTED4	5,0	Y8001AS	8904	58
C4 Picasso 2.0 Hdi 165		2.0	120	4	11.10-	DW10CTED4	5,0	Y8001AS	8904	58

C4 PICASSO II

C4 Picasso II 1.6 HDi 90		1.6	68	4	02.13-	DV6DTEd	5,0	Y8001AS	8904	58
C4 Picasso II 1.6 e-HDi 115		1.6	85	4	02.13-	DV6C	5,0	Y8001AS	8904	58
C4 Picasso II 2.0 BlueHdi 150		2.0	110	4	08.13-	DW10FD	5,0	Y8001AS	8904	58

C5

C5 Phase 2 1.6 Hdi		1.6	80	4	09.04-	DV6TED4	11,0	YE05	91322	73
C5 Hdi		1.6	81	4	03.06-	DV6	11,0	YE05	91322	73
C5 1.6 e-HDi/HDi	RW9HL0, RW9HL8, RW9HR8, RW9HRA	1.6	82	4	07.10-	DV6C	5,0	Y8001AS	8904	58
C5 1.6 e-HDi/HDi	RW9HL8, RW9HRA	1.6	84	4	06.12-	DV6C	5,0	Y8001AS	8904	58
C5 2.0 HDi	DCRHYB	2.0	66	4	05.01-10.03	DW10	11,0	Y-504J	1441	24
C5 2.0 HDi	DCRHYB	2.0	66	4	05.01-10.03	DW10TD	11,0	Y-504J	1441	24
C5 2.0 HDi	DERHYB	2.0	66	4	05.01-10.03	DW10TD	11,0	Y-504J	1441	24
C5 Hdi		2.0	66	4	06.02-	DW10ATD	11,0	Y-504J	1441	24
C5 2.0 HDi	DERHYB	2.0	66	4	06.02-08.04	DW10TD	11,0	Y-504J	1441	24
C5 2.0 HDi	DERHSB, DERHSE	2.0	79	4	06.02-08.04	DW10ATED	11,0	Y-504J	1441	24
C5 2.0 HDi	DERHQB, DERHZE	2.0	80	4	06.02-08.04	DW10ATED	11,0	Y-504J	1441	24
C5 Hdi		2.0	81	4	02.01-	DW10ATED	11,0	Y-504J	1441	24
C5 2.0 Hdi		2.0	100	4	09.04-	DW10BTED4	11,0	Y1005J	7957	56
C5 2.2 HDi	DE4HXB, DE4HXF	2.2	98	4	06.02-08.04	DW12TED4	11,0	Y-504J	1441	24
C5 Hdi		2.2	98	4	09.04-08.05	DW12TED4	11,0	Y1005J	7957	56
C5 Hdi		2.2	100	4	10.00-08.04	DW12TED4	11,0	Y1005J	7957	56
C5 Hdi 2.2		2.2	100	4	02.01-	DW12TED4	11,0	Y-504J	1441	24
C5 2.2 Hdi		2.2	125	4	05.06-	DW12BTED4	11,0	YE08	4966	
C5 Phase 2 Hdi 2.2		2.2	126	4	04.08-	DW12BTED4	11,0	YE08	4966	

C5 III

C5 III 1.6 HDi		1.6	80	4	02.08-	DV6TED4	11,0	YE05	91322	73
C5 III 1.6 Hdi 110		1.6	82	4	07.10-	DV6C	5,0	Y8001AS	8904	58
C5 III 1.6 Hdi 115		1.6	84	4	01.12-	DV6C	5,0	Y8001AS	8904	58





ℓ kW C
y
i



Stock-No
D-POWER

CITROËN

C5 III

C5 III 2.0 HDi	2.0	100	4	02.08-	DW10BTED4	11,0	Y1005J	7957	56
C5 III 2.0 HDi 140	2.0	103	4	04.09-	DW10BTED4	11,0	Y1005J	7957	56
C5 III 2.0 HDi 165	2.0	120	4	04.09-	DW10CTED4	5,0	Y8001AS	8904	58
C5 III 2.2 HDi	2.2	125	4	02.08-	DW12BTED4	11,0	YE08	4966	
C5 III 2.7 V6 HDi	2.7	150	6	02.08-	DT17TED4	11,0	YE12	7794	

C6

C6 2.2 Hdi	2.2	125	4	11.06-	DW12BTED4	11,0	YE08	4966	
C6 2.7 V6 Hdi	2.7	150	6	12.05-	DT17	11,0	YE12	7794	

C8

C8 Hdi	2.0	79	4	04.02-08.07	DW10ATED4	11,0	Y1005J	7957	56	
C8 Hdi 16V	2.0	80	4	07.02-	DW10TED4, RHT	11,0	Y-504J	1441	24	
C8 Hdi	2.0	80	4	10.02-02.07	DW10UTED4	11,0	Y1005J	7957	56	
C8 2.0 HDi	EBRHWG	2.0	80	4	10.02-02.07	DW10ATED4	11,0	Y-504J	1441	24
C8 Hdi		2.0	81	4	04.02-	DW10ATED4	11,0	Y1005J	7957	56
C8 2.0 HDi	EBRHTB, EBRHTG	2.0	81	4	04.02-12.09	DW10ATED4	11,0	Y-504J	1441	24
C8 Hdi		2.0	88	4	03.07-	DW10UTED4	11,0	Y1005J	7957	56
C8 Hdi		2.0	100	4	03.06-	DW10BTED4	11,0	Y1005J	7957	56
C8 2.0 Hdi 160		2.0	120	4	04.10-	DW10CTED4	5,0	Y8001AS	8904	58
C8 Hdi		2.2	94	4	04.02-07.06	DW12TED4	11,0	Y1005J	7957	56
C8 Hdi 16V		2.2	94	4	07.02-	DW12TED4, 4HW	11,0	Y-504J	1441	24
C8 Hdi		2.2	96	4	.02-	DW12	11,0	Y-504J	1441	24
C8 2.2 Hdi		2.2	125	4	06.06-	DW12BTED4	11,0	YE08	4966	

C-CROSSER

C-Crosser Hdi	2.2	115	4	06.07-	DW12MTED4	11,0	YE08	4966	
---------------	-----	-----	---	--------	-----------	------	------	------	--

C-ELYSÉE

C-Elysée 1.6 HDi 92	1.6	68	4	.12-	DV6DTED, DV6DTEDM	5,0	Y8001AS	8904	58
---------------------	-----	----	---	------	-------------------	-----	---------	------	----

DISPATCH

Dispatch 1.6 HDi	VF79HUC	1.6	66	4	11.06-	DV6UTED4	11,0	YE05	91322	73
Dispatch		1.9		4	09.96-07.98	XUD9A, XUD9TE	11,0	Y-924J	7906	1
Dispatch		1.9		4	09.98-	DW8, DW8B	11,0	Y-503J	1009	10
Dispatch		1.9		4	09.98-	XUD9A, XUD9TE	11,0	Y-924J	7906	1
Dispatch		2.0		4	03.00-	DW10	11,0	Y-504J	1441	24

DS3

DS3 1.4 e-Hdi 70		1.4	50	4	04.10-	DV4C	11,0	YE05	91322	73
DS3 1.6 Hdi 90		1.6	68	4	11.09-	DV6C	5,0	Y8001AS	8904	58
DS3 1.6 e-Hdi 90		1.6	68	4	01.13-	DV6DTED	5,0	Y8001AS	8904	58
DS3 1.6 Hdi 110		1.6	82	4	11.09-	DV6CTED4	5,0	Y8001AS	8904	58
DS3 1.6 e-Hdi 115		1.6	84	4	08.12-	DV6C	5,0	Y8001AS	8904	58

DS4

DS4 1.6 Hdi		1.6	68	4	05.11-	DV6DTED	5,0	Y8001AS	8904	58
DS4 1.6 e-Hdi 110		1.6	81	4	04.11-	DV6C	5,0	Y8001AS	8904	58
DS4 1.6 Hdi 110		1.6	82	4	04.11-	DV6C	5,0	Y8001AS	8904	58
DS4 1.6 e-Hdi 115		1.6	84	4	08.12-	DV6C	5,0	Y8001AS	8904	58
DS4 2.0 Hdi 140		2.0	100	4	04.11-	DW10CB	5,0	Y8001AS	8904	58
DS4 2.0 Hdi 160		2.0	120	4	04.11-	DW10CTED4	5,0	Y8001AS	8904	58





e kW C
y
i



Stock-No
P-POWER™

CITROËN

DS5

DS5 1.6 e-Hdi 110	1.6	82	4	11.11-	DV6C	5,0	Y8001AS	8904	58
DS5 1.6 e-Hdi 115	1.6	84	4	06.12-	DV6C	5,0	Y8001AS	8904	58
DS5 1.6 e-Hdi 115	1.6	85	4	11.13-	DV6C	5,0	Y8001AS	8904	58
DS5 2.0 HDi 140	2.0	100	4	11.11-	DW10CBDTR	5,0	Y8001AS	8904	58
DS5 2.0 HDi 165	2.0	120	4	11.11-	DW10CTED4	5,0	Y8001AS	8904	58
DS5 2.0 HDi 165 Hybrid4	2.0	120	4	11.11-	DW10CTED4	5,0	Y8001AS	8904	58
DS5 2.0 Blue HDi 180	2.0	133	4	08.13-	DW10FC	5,0	Y8001AS	8904	58

EVASION

Evasion TD	1.9	66	4	03.94-08.98	XUD9TF	11,0	Y-924J	7906	1	
Evasion	1.9	68	4	09.98-09.02	XUD9TF, XUD9BTF	11,0	Y-924J	7906	1	
Evasion 2.0 HDi	AFRHWB	2.0	80	4	09.99-10.02	DW10ATED4	11,0	Y1005J	7957	56
Evasion Hdi	2.0	81	4	09.98-09.02	DW10ATED	11,0	Y-504J	1441	24	
Evasion TD	2.1	80	4	05.96-04.97	XUD11BTE	11,0	Y-924J	7906	1	
Evasion TD	2.1	80	4	05.97-12.98	XUD11BTE	11,0	Y-924J	7906	1	

JUMPER

Jumper D	1.9	52	4	03.94-05.95	XUD9AU	11,0	Y-924J	7906	1
Jumper	1.9	52	4	06.95-	XUD9AU	11,0	Y-924J	7906	1
Jumper TD	1.9	68	4	03.94-08.98	XUD9TF	11,0	Y-924J	7906	1
Jumper	1.9	68	4	09.98-	XUD9TF	11,0	Y-924J	7906	1
Jumper Hdi	2.0	66	4	09.98-	DW10TD	11,0	Y-504J	1441	24
Jumper 2.2 Hdi	2.2	74	4	02.02-06.06	DW12UTED	11,0	Y1005J	7957	56
Jumper Hdi	2.2	74	4	04.02-	DW12TED	11,0	Y-504J	1441	24
Jumper 2.2 Hdi 100	2.2	74	4	04.06-	4HV	11,5	Y-548J	94832	75
Jumper Hdi	2.2	76	4	09.98-	DW10TED4	11,0	Y-504J	1441	24
Jumper 2.2 Hdi 120	2.2	88	4	04.06-	4HU	11,5	Y-548J	94832	75
Jumper Hdi	2.2	100	4	09.98-	DW12TED4	11,0	Y-504J	1441	24
Jumper D	2.5	63	4	03.94-	DJ5	11,0	Y-924J	7906	1
Jumper TD	2.5	76	4	03.94-08.96	DJ5T	11,0	Y-924J	7906	1
Jumper Tdi	2.5	78	4	09.96-	DJ5TED	11,0	Y-738U	5390	
Jumper Hdi	2.8	93	4	09.00-04.02	4HY	11,0	Y-502R	3852	
Jumper Hdi 145	3.0	107	4	07.10-	F30DT	11,0	Y8005J	96853	64
Jumper Hdi 160	3.0	116	4	06.09-	F30DT	11,0	Y8005J	96853	64

JUMPER 27

Jumper	231A	1.9	50	4	07.99-04.02	XUD9A	11,0	Y-924J	7906	1
--------	------	-----	----	---	-------------	-------	------	--------	------	---

JUMPER 31

Jumper	233D	2.0	62	4	11.01-04.02	DW10TD	11,0	Y-504J	1441	24
--------	------	-----	----	---	-------------	--------	------	--------	------	----

JUMPY

Jumpy 1.6 Hdi	1.6	66	4	02.07-	DV6UTED4	11,0	YE05	91322	73
Jumpy D	1.9	51	4	01.96-08.98	XUD9A	11,0	Y-924J	7906	1
Jumpy D	1.9	51	4	09.98-	DW8	11,0	Y-503J	1009	10
Jumpy D	1.9	51	4	09.98-	XUD9A	11,0	Y-924J	7906	1
Jumpy TD	1.9	68	4	01.96-08.98	XUD9TF, BTF	11,0	Y-924J	7906	1
Jumpy TD	1.9	68	4	09.96-	XUD9TF, BTF	11,0	Y-924J	7906	1
Jumpy Hdi	2.0	70	4	02.00-	DW10TED	11,0	Y-504J	1441	24
Jumpy 2.0 Hdi 95	2.0	72	4	07.11-	DW10CE	5,0	Y8001AS	8904	58





l kW C
y
i



Stock-No
D-POWER

CITROËN

JUMPY

Jumpy Hdi	2.0	81	4	02.00-	DW10ATED	11,0	Y-504J	1441	24
Jumpy 2.0 Hdi	2.0	81	4	05.02-10.06	DW10ATED4	11,0	Y1005J	7957	56
Jumpy 2.0 Hdi 120	2.0	88	4	11.06-	DW10UTED4	11,0	Y1005J	7957	56
Jumpy 2.0 Hdi 125	2.0	94	4	07.11-	DW10CD	5,0	Y8001AS	8904	58
Jumpy 2.0 Hdi 140	2.0	100	4	11.06-	DW10BTED4	11,0	Y1005J	7957	56
Jumpy 2.0 Hdi 165	2.0	120	4	07.10-	DW10CTED4	5,0	Y8001AS	8904	58

NÉMO

Nemo 1.3 HDi 75	1.3	55	4	10.10-	F13DTE5 (FHZ)	4,3	Y9001AS	97719	72
Nemo 1.4 Hdi	1.4	51	4	02.08-	DV4TED	11,0	YE05	91322	73

RELAY

Relay	1.9		4	03.94-08.98	XUD9TF, XUD9AU	11,0	Y-924J	7906	1
Relay	1.9		4	09.98-	XUD9TF	11,0	Y-924J	7906	1
Relay	2.0		4	09.98-	DW10TD, DU	11,0	Y-504J	1441	24
Relay	2.5		4	03.94-	DJ5, DJ5T	11,0	Y-924J	7906	1
Relay	2.5		4	09.96-	DJ5TED 12V	11,0	Y-738U	5390	

SAXO I

Saxo I	1.5	43	4	05.96-08.99	TUD 5	11,0	Y-503J	1009	10
--------	-----	----	---	-------------	-------	------	--------	------	----

SAXO II

Saxo II	1.5	43	4	09.99-05.03	TUD 5	11,0	Y-503J	1009	10
---------	-----	----	---	-------------	-------	------	--------	------	----

SYNERGIE

Synergie	1.9		4	10.95-08.98	XUD9BTF, L3	11,0	Y-924J	7906	1
Synergie	1.9		4	09.98-10.00	XUD9TE, XUD9BTF	11,0	Y-924J	7906	1
Synergie 2.0 HDi	2.0	80	4	09.99-02.03	DW10ATED4	11,0	Y1005J	7957	56
Synergie	2.0		4	08.99-	DW10TED	11,0	Y-504J	1441	24

XANTIA

Xantia D	1.9	51	4	03.93-01.96	XUD 9 A, L	11,0	Y-924J	7906	1
Xantia	1.9	55	4	05.94-	XUD9A	11,0	Y-924J	7906	1
Xantia	1.9	55	4	09.98-	XUD9A, L	11,0	Y-924J	7906	1
Xantia TD	1.9	68	4	06.93-08.98	XUD9TF	11,0	Y-924J	7906	1
Xantia	1.9	68	4	09.98-12.00	XUD9BTF, XUD9BSD	11,0	Y-924J	7906	1
Xantia Hdi	2.0	66	4	10.98-	DW10TD	11,0	Y-504J	1441	24
Xantia 2.0 HDi	2.0	66	4	06.99-04.03	DW10TD	11,0	Y-504J	1441	24
Xantia Hdi	2.0	81	4	10.98-12.01	DW10ATED	11,0	Y-504J	1441	24
Xantia TD	2.1	80	4	06.95-08.98	XUD11BTE	11,0	Y-924J	7906	1
Xantia	2.1	80	4	09.98-	XUD11BTF	11,0	Y-924J	7906	1

XM

XM D 12 D	2.1	60	4	05.89-06.94	XUD11A, L	11,0	Y-924J	7906	1
XM D 12 TD	2.1	80	4	05.89-08.98	XUD11ATE, L, BTE	11,0	Y-924J	7906	1
XM	2.1	80	4	09.98-12.00	XUD11ATE, L, BTE	11,0	Y-924J	7906	1
XM TD	2.5	96	4	07.94-12.00	DK5ATE	11,0	Y-924J	7906	1

XSARA

Xsara	1.5	43	4	09.97-08.00	TUD5	11,0	Y-503J	1009	10
Xsara	1.8	43	4	10.97-09.00	XUD7	11,0	Y-924J	7906	1
Xsara	1.9	50	4	09.97-09.00	XUD9A DJY	11,0	Y-924J	7906	1
Xsara	1.9	51	4	06.99-08.00	DW8	11,0	Y-503J	1009	10





e kW C
y i



Stock-No
P-POWER™

CITROËN

XSARA

Xsara TD	1.9	66	4	10.97-09.00	XUD9TE DHY	11,0	Y-924J	7906	1	
Xsara Hdi	2.0	66	4	04.99-08.00	DW10TD	11,0	Y-504J	1441	24	
Xsara 2.0 HDi	N3RHY, N4RHY	2.0	66	4	09.00-03.05	DW10TD	11,0	Y-504J	1441	24

XSARA II

Xsara 2 Hdi	1.4	51	4	02.03-12.04	DV4TD	11,0	YE04	1684	40
Xsara 2 Hdi	1.4	51	4	12.04-	DV4TD	11,0	YE05	91322	73
Xsara 2	1.5	43	4	09.00-	TUD5	11,0	Y-503J	1009	10
Xsara 2	1.9	52	4	09.00-	DW8 WJZ	11,0	Y-503J	1009	10
Xsara 2 Hdi	2.0	66	4	09.00-12.02	DW10TD RHY	11,0	Y-504J	1441	24
Xsara 2 Hdi	2.0	81	4	05.01-	DW10ATED RHZ	11,0	Y-504J	1441	24

XSARA PICASSO

Xsara Picasso 1.6 Hdi	1.6	66	4	09.05-	DV6	11,0	YE05	91322	73
Xsara Picasso 1.6 Hdi	1.6	81	4	05.04-06.06	DV6	11,0	YE04	1684	40
Xsara Picasso Hdi	2.0	66	4	01.00- .07	DW10TD	11,0	Y-504J	1441	24
Xsara Picasso Hdi	2.0	81	4	01.00- .07	DW10TD	11,0	Y-504J	1441	24

ZX

ZX 1.8 Reflex D	1.8	44	4	03.91-	XUD 7 A9A	11,0	Y-924J	7906	1
ZX 1.8 D	1.8	44	4	03.91-04.94	XUD 7 A9A	11,0	Y-924J	7906	1
ZX 1.8 D	1.8	44	4	05.94-07.98	XUD7	11,0	Y-924J	7906	1
ZX 1.9 D	1.9	38	4	05.94-07.98	XUD9A, L	11,0	Y-924J	7906	1
ZX 1.9 D	1.9	47	4	03.91-04.94	XUD 9 A, L D9B	11,0	Y-924J	7906	1
ZX 1.9 TD	1.9	68	4	09.92-04.94	XUD 9 T, L D8A	11,0	Y-924J	7906	1
ZX 1.9 TD	1.9	68	4	05.94-07.98	XUD9T, L	11,0	Y-924J	7906	1

DACIA

DOKKER

Dokker 1.5 dCi	FE, KE	1.5	55	4	11.12-	K9K612	4,4	Y1035AS	94103	77
Dokker 1.5 dCi	FE, KE	1.5	66	4	11.12-	K9K612	4,4	Y1035AS	94103	77

DUSTER II

Duster 1.5 dCi	HSM5, HSMW	1.5	63	4	03.10-01.18	K9K796	12,0	Y-732J	5605	4
Duster 1.5 dCi	HS	1.5	63	4	04.10-	K9K796	12,0	Y-732J	5605	4
Duster 1.5 dCi 4x2	HS	1.5	66	4	10.10-	K9K892	4,4	Y1035AS	94103	77
Duster 1.5 dCi 4x4	HS	1.5	66	4	10.10-	K9K884	12,0	Y-732J	5605	4
Duster 1.5 dCi	HS	1.5	79	4	06.10-	K9K896, K9K898	4,4	Y1035AS	94103	77
Duster 1.5 dCi	HS	1.5	80	4	08.13-	K9K856, K9K858	4,4	Y1035AS	94103	77
Duster 1.5 dCi	HS	1.5	81	4	06.10-	K9K 898	4,4	Y1035AS	94103	77

LODGY

Lodgy 1.5 dCi	JS	1.5	66	4	03.12-	K9K612	4,4	Y1035AS	94103	77
Lodgy 1.5 dCi	JS	1.5	79	4	03.12-	K9K846	4,4	Y1035AS	94103	77

LOGAN I

Logan I 1.5 dCi	LS0J	1.5	48	4	08.05-12.12	K9K790	12,0	Y-732J	5605	4
Logan I 1.5 dCi	LS, FS	1.5	48	4	09.05-	K9K 790	12,0	Y-732J	5605	4
Logan I 1.5 dCi	US00, US0J, US0Y	1.5	48	4	04.08-12.12	K9K794	12,0	Y-732J	5605	4
Logan I 1.5 dCi	LS, FS	1.5	50	4	01.06-	K9K 792	12,0	Y-732J	5605	4





l kW C
Y
I



Stock-No
D-POWER

DACIA

LOGAN I

Logan I 1.5 dCi	LS0K, FS0K, US0K	1.5	50	4	01.06-12.12	K9K792	12,0	Y-732J	5605	4
Logan I 1.5 dCi	LS, FS	1.5	55	4	05.10-	K9K 892	4,4	Y1035AS	94103	77
Logan I 1.5 dCi	LS, FS	1.5	63	4	09.07-	K9K 796	12,0	Y-732J	5605	4
Logan I 1.5 dCi	LS0W, US0W, FS0W	1.5	63	4	09.07-12.12	K9K796	12,0	Y-732J	5605	4

LOGAN II

Logan II 1.5 dCi 75	L8	1.5	55	4	11.12-	K9K 612	4,4	Y1035AS	94103	77
Logan II 1.5 dCi 90	L8	1.5	66	4	11.12-	K9K 612	4,4	Y1035AS	94103	77

LOGAN MCV I

Logan MCV I 1.5 dCi	KS	1.5	50	4	08.06-06.13	K9K 792	12,0	Y-732J	5605	4
Logan MCV I 1.5 dCi	KS0K	1.5	50	4	08.06-06.13	K9K792	12,0	Y-732J	5605	4
Logan MCV I 1.5 dCi	KS	1.5	55	4	05.10-06.13	K9K 892	4,4	Y1035AS	94103	77
Logan MCV I 1.5 dCi	KS	1.5	63	4	09.07-12.12	K9K 796	12,0	Y-732J	5605	4
Logan MCV I 1.5 dCi	KS0W	1.5	63	4	09.07-12.12	K9K796	12,0	Y-732J	5605	4
Logan MCV I 1.5 dCi	KS	1.5	65	4	05.10-06.13	K9K 892	4,4	Y1035AS	94103	77

LOGAN MCV II

Logan MCV II 1.5 dCi 75	K8	1.5	55	4	02.13-	K9K 612	4,4	Y1035AS	94103	77
Logan MCV II 1.5 dCi 90	K8	1.5	66	4	02.13-	K9K 612	4,4	Y1035AS	94103	77

LOGAN PICK-UP

Logan Pick-up 1.5 dCi	US	1.5	50	4	03.08-	K9K 792	12,0	Y-732J	5605	4
Logan Pick-up 1.5 dCi	US	1.5	55	4	05.10-	K9K 892	4,4	Y1035AS	94103	77
Logan Pick-up 1.5 dCi	US	1.5	63	4	03.08-	K9K 796	12,0	Y-732J	5605	4
Logan Pick-up 1.5 dCi	US	1.5	65	4	05.10-	K9K 892	4,4	Y1035AS	94103	77

SANDERO I

Sandero I 1.5 dCi	BS00, BS0J, BS0Y	1.5	48	4	06.08-12.12	K9K790	12,0	Y-732J	5605	4
Sandero I 1.5 dCi	BS0K	1.5	50	4	11.08-12.12	K9K792	12,0	Y-732J	5605	4
Sandero I Stepway 1.5 dCi	BS0K	1.5	50	4	11.08-12.12	K9K792	12,0	Y-732J	5605	4
Sandero I 1.5 dCi	BS0W	1.5	63	4	11.08-12.12	K9K796	12,0	Y-732J	5605	4

SANDERO II

Sandero II 1.5 dCi 75	B8	1.5	55	4	01.13-	K9K 838	4,4	Y1035AS	94103	77
Sandero II 1.5 dCi 90	B8	1.5	66	4	01.13-	K9K 612	4,4	Y1035AS	94103	77

DAEWOO

KORANDO

Korando TD		2.3	74	4	04.00-		11,5	Y-916J	5906	6
Korando TD, Cabriolet		2.9	88	5	04.00-		11,5	Y-916J	5906	6
Korando		2.9		4	04.00-		11,5	Y-916J	5906	6

MUSSO

Musso SLTD		2.3	74	4	04.00-		11,5	Y-916J	5906	6
Musso SELTD		2.9	88	5	04.00-		11,5	Y-916J	5906	6
Musso		2.9		4	04.00-		11,5	Y-916J	5906	6

DAF

400

400 Serie D		2.5	53	4	04.89-08.93		11,0	Y-924J	7906	1
400 Serie TD		2.5	71	4	04.89-08.93		11,0	Y-924J	7906	1





e kW C
y
i



Stock-No
D-POWER™

DAIHATSU

CHARADE

Charade CL10, CL60	1.0	27	4	.86-	CL	11,0	Y-703R	3782	
Charade CL50	1.0		4	.86-	CL	11,0	Y-703R	3782	

FOURTRAK

Fourtrak	2.8		4	.84- .93	DL50	7,0	Y-146R	7492	
Fourtrak	2.8		4	10.89- .93	DLT	7,0	Y-146R	7492	

ROCKY

Rocky	2.8	67	4	12.87-04.93	DL51	7,0	Y-146R	7492	
Rocky TD	2.8	67	4	12.87-04.93	DL 51	7,0	Y-146R	7492	
Rocky TD	2.8	72	4	05.93-	DL 52	7,0	Y-146R	7492	
Rocky TD	2.8	75	4	09.91-	DL 52	7,0	Y-146R	7492	

DODGE

NITRO

Nitro 2.8 CRD	KA	2.8	130	4	10.06-04.12	ENR	4,4	Y8011AS	90403	
Nitro 2.8 CRD	KA	2.8	130	4	10.06-04.12	ENS	4,4	Y8011AS	90403	

FIAT

500

500 1.3 JTDM	312	1.3	70	4	11.09-	199B1000	4,3	Y9001AS	97719	72
FIAT 500 L 1.3 JTD Multijet (For OE-No. 55238404)	199LXY11, 199LYM1A	1.3	70	4	06.14-	330A1000	4,3	Y9001AS	97719	72
FIAT 500 X 1.3 JTD Multijet (For OE-No. 55238404)	334AXH1A	1.3	70	4	11.14-	55266963	4,3	Y9001AS	97719	72
500X 1.6 Multijet	334	1.6	85	4	09.14-	55260384	4,4	Y9003AS	94251	78
500X 2.0 Multijet	334	2.0	103	4	09.14-	55263087	4,4	Y9003AS	94251	78
500X 2.0 Multijet	334	2.0	103	4	09.14-	55263088	4,4	Y9003AS	94251	78

500 C

500C 1.3 JTD Multijet	312	1.3	55	4	06.09-	169A1000	11,0	Y8003J	97256	62
500C 1.3 JTDM	312	1.3	70	4	11.09-	199B1000	4,3	Y9001AS	97719	72

500 L

500 L 1.3 16V JTD Multijet	199	1.3	62	4	09.12-	199B4000	4,3	Y9001AS	97719	72
500 L 1.6 16V Multijet	199	1.6	77	4	09.12-	199B5000	4,3	Y9001AS	97719	72
500 L 1.6 16V Multijet	199	1.6	88	4	09.13-	955A3000	4,4	Y9003AS	94251	78

500 MY07

500 1.3 JTD Multijet	312	1.3	56	4	07.07-	169A1000	11,0	Y8003J	97256	62
500 1.3 JTD Multijet	312	1.3	70	4	11.09-	199B1000	4,3	Y9001AS	97719	72

ALBEA / SIENA

Albea / Siena 1.3 JTD Multijet	178	1.3	51	4	06.03-12.11	188A9000	11,0	Y8003J	97256	62
Albea / Siena 1.7 TD	178	1.7	51	4	02.06-12.12	176A3000	11,0	Y-924J	7906	1
Albea / Siena 1.9 D	178	1.9	46	4	11.00-	223A6000	11,0	Y-939J	5059	43

BRAVA / BRAVO

Brava / Bravo D	182	1.9	55	4	09.95-10.96	160A7000	11,0	Y-924J	7906	1
Brava / Bravo TD	182	1.9	55	4	04.96-11.99	182A8000	11,0	Y-928U	4389	29
Brava / Bravo 1.9 JTD	182	1.9	74	4	09.00-10.01	182B9000	11,0	Y-534J	3413	36
Brava / Bravo 1.9 JTD (Engine No->1716458)	182	1.9	77	4	09.98-11.99	AR32.302	11,0	Y-747U	4694	26
Brava / Bravo 1.9 JTD (Engine No1716450->)	182	1.9	77	4	12.99-09.00	182B4000	11,0	Y-534J	3413	36





l kW C
Y
I



Stock-No
D-POWER

FIAT

BRAVO

Bravo 1.9 D	182	1.9	48	4	10.95-05.97	160A7000	11,0	Y-924J	7906	1
-------------	-----	-----	----	---	-------------	----------	------	--------	------	---

BRAVO MY07

Bravo 1.6 JTD Multijet	198	1.6	66	4	03.08-12.14	198A6000	4,4	Y9003AS	94251	78
Bravo 1.6 JTD Multijet	198	1.6	77	4	03.08-12.14	198A3000	4,4	Y9003AS	94251	78
Bravo 1.6 JTD Multijet	198	1.6	77	4	03.08-12.14	844A3000	4,4	Y9003AS	94251	78
Bravo 1.6 JTDM	198	1.6	85	4	11.08-12.14	955A4000	4,4	Y9003AS	94251	78
Bravo 1.6 JTDM	198	1.6	88	4	03.08-12.14	198A2000	4,4	Y9003AS	94251	78
Bravo 1.9 JTD	198	1.9	66	4	04.07-12.08	192B5000	11,0	Y1030J	90828	70
Bravo 1.9 JTD Multijet	198	1.9	85	4	01.07-12.09	192A1000	11,0	Y-534J	3413	36
Bravo 1.9 JTD Multijet	198	1.9	85	4	04.07-12.09	192B4000, 192A1000	11,0	Y1030J	90828	70
Bravo 1.9 JTD	198	1.9	88	4	04.07-12.14	192A8000	11,0	Y1030J	90828	70
Bravo 1.9 JTD	198	1.9	110	4	01.07-12.14	937A5000	11,0	YE07	6092	
Bravo 2.0 JTDM	198	2.0	120	4	09.08-12.14	844A2000	4,4	Y9003AS	94251	78
Bravo 2.0 JTDM	198	2.0	121	4	09.08-12.14	198A5000	4,4	Y9003AS	94251	78

CROMA

Croma 1.9 TD	154	1.9	69	4	07.90- .98	154C6000, 154D1000	11,0	Y-739R	6639	
Croma 2.5 Td	154	2.5	85	4	02.89-12.92	814497200, 2200	11,0	Y-924J	7906	1

CROMA MY05

Croma 1.9 MJTD	194	1.9	85	4	06.05-08.06	939A7000	11,0	Y-534J	3413	36
Croma 1.9 MJTD	194	1.9	85	4	09.06-12.11	939A7000	11,0	Y1030J	90828	70
Croma 1.9 MJTD	194	1.9	88	4	06.05-08.06	939A1000	11,0	Y-534J	3413	36
Croma 1.9 MJTD	194	1.9	88	4	09.06-12.11	939A1000	11,0	Y1030J	90828	70
Croma 1.9 MJTD	194	1.9	100	4	10.05-10.07	939A8000	11,0	YE07	6092	
Croma 1.9 MJTD	194	1.9	110	4	06.05-12.11	939A2000	11,0	YE07	6092	
Croma 2.4 MJTD	194	2.4	147	5	06.05-12.11	939A3000	11,0	YE07	6092	

DOBLO

FIAT Doblo 1.3 JTD Multijet (For OE-No. 55238404)	263YXM1A, 263HXM1A	1.3	55	4	03.15-	263A6000	4,3	Y9001AS	97719	72
FIAT Doblo 1.3 JTD Multijet (For OE-No. 55238404)	263HXT1A, 263WXT1A, 263ZXT1A, 263YXT1A	1.3	59	4	03.16-	225A2000	4,3	Y9001AS	97719	72
FIAT Doblo 1.3 JTD Multijet (For OE-No. 55238404)	263AXU1A, 263YXU1A, 263WXU1A, 263ZXU1A, 263HXU1A	1.3	70	4	03.16-	330A1000	4,3	Y9001AS	97719	72
Doblò 1.6	263	1.6	70	4	07.15-	263A7000	4,4	Y9003AS	94251	78
Doblò 1.6 Multijet	263	1.6	88	4	07.15-	940C1000	4,4	Y9003AS	94251	78

DOBLO (119)

Doblò 1.3 JTD Multijet		1.3	51	4	11.03-12.05	188A9000	11,0	Y8003J	97256	62
Doblò 1.3 JTD Multijet		1.3	55	4	08.05-08.13	199A2000	11,0	Y8003J	97256	62
Doblò 1.3 JTD Multijet		1.3	62	4	11.05-07.09	223A9000	11,0	Y8003J	97256	62
Doblò 1.9 D		1.9	46	4	11.00-04.04	223A6000	11,0	Y-939J	5059	43
Doblò 1.9 JTD		1.9	74	4	10.01-06.03	182B9000	11,0	Y-534J	3413	36
Doblò 1.9 JTD		1.9	74	4	10.01-06.03	223B2000	11,0	Y-534J	3413	36
Doblò 1.9 JTD		1.9	77	4	07.03-09.05	223A7000	11,0	Y-534J	3413	36
Doblò 1.9 JTD		1.9	77	4	07.03-09.05	223B1000	11,0	Y-534J	3413	36
Doblò 1.9 JTD-/Multijet		1.9	88	4	10.05-07.09	186A9000	11,0	Y1030J	90828	70





e kW C
y i



Stock-No
D-POWER™

FIAT

DOBLO (152)

Doblò 1.3 JTD Multijet	152	1.3	66	4	02.10-	199A3000	4,3	Y9001AS	97719	72
Doblò 1.3 JTD Multijet		1.3	66	4	02.10-	263A2000	4,3	Y9001AS	97719	72
Doblò 1.6 JTD Multijet		1.6	66	4	02.10-	263A4000	4,4	Y9003AS	94251	78
Doblò 1.6 JTD Multijet/Multijet		1.6	74	4	02.10-	263A3000	4,4	Y9003AS	94251	78
Doblò 1.6 JTD Multijet/Multijet		1.6	77	4	02.10-	198A3000	4,4	Y9003AS	94251	78
Doblò 2.0 JTD Multijet		2.0	99	4	02.10-	263A1000	4,4	Y9003AS	94251	78

DUCATO

Ducato 1.9	290	1.9	52	4	06.90-05.94	149B1000	11,0	Y-924J	7906	1
Ducato 1.9 TD	290	1.9	60	4	06.90-05.94	280A1000	11,0	Y-924J	7906	1
Ducato 2.0 JTD	230	2.0	62	4	07.01-04.02	RHV	11,0	Y-504J	1441	24
Ducato 2.0 Multijet		2.0	85	4	06.11-	250A1000	4,4	Y9003AS	94251	78
Ducato 2.2 Multijet	250	2.2	74	4	07.06-05.11	4HV	11,5	Y-548J	94832	75
Ducato 2.3 JTD	244	2.3	81	4	12.01-07.06	F1AE0481C	11,0	Y8005J	96853	64
Ducato 2.3 Multijet	250	2.3	83	4	10.11-07.14	F1AE3481G	11,0	Y8005J	96853	64
Ducato 2.3 JTD		2.3	88	4	04.02-	F1AE0481C, F1AE0481D, F1AE0481N	11,0	Y8005J	96853	64
Ducato 2.3 Multijet	250	2.3	88	4	07.06-05.11	F1AE0481D	11,0	Y8005J	96853	64
Ducato 2.3 Multijet	250	2.3	93	4	12.09-07.14	F1AE0481T	11,0	Y8005J	96853	64
Ducato 2.3 Multijet	250	2.3	96	4	01.07-	F1AE0481N	11,0	Y8005J	96853	64
Ducato 2.3 Multijet	250	2.3	96	4	01.07-	F1AE3481D	11,0	Y8005J	96853	64
Ducato 2.3 Multijet	250	2.3	96	4	06.11-	F1AE3481D	11,0	Y8005J	96853	64
Ducato 2.3 Multijet	250	2.3	96	4	03.14-	F1AE3481D	11,0	Y8005J	96853	64
Ducato 2.3 Multijet	250	2.3	109	4	06.11-	F1AE3481E	11,0	Y8005J	96853	64
Ducato 2.5	290	2.5	55	4	06.90-05.94	814467	11,0	Y-924J	7906	1
Ducato 2.5	230	2.5	62	4	06.94-04.98	814067	11,0	Y-924J	7906	1
Ducato 2.5 JTD	290	2.5	70	4	06.90-05.94	814027	11,0	Y-924J	7906	1
Ducato 2.8		2.8	64		02.98-	814063	11,0	Y-502R	3852	
Ducato 3.0 Multijet	250	3.0	107	4	04.10-07.14	F1CE3481N	11,0	Y8005J	96853	64
Ducato 3.0 Multijet	250	3.0	115	4	.06-	F1CE0481D	11,0	Y8005J	96853	64
Ducato 3.0 Multijet	250	3.0	130	4	06.11-	F1CE3481E	11,0	Y8005J	96853	64

DUCATO 10

Ducato 1.9 D	230	1.9	50	4	05.98-10.00	DJY	11,0	Y-924J	7906	1
Ducato 1.9 D		1.9	51	4	03.94-08.98	230A2000	11,0	Y-924J	7906	1
Ducato 1.9 TD		1.9	59	4	03.94-04.98	230A4000	11,0	Y-924J	7906	1
Ducato 1.9 TD		1.9	60	4	03.94-08.98	230A3000	11,0	Y-924J	7906	1

DUCATO 14

Ducato 2.5 D		2.5	55	4	01.86-02.94	814467220	11,0	Y-924J	7906	1
Ducato 2.5 TD		2.5	62	4	03.94-04.98	8140672200	11,5	Y-910J	3617	3
Ducato 2.5 TD 4x4		2.5	68	4	01.89-02.94	814421220	11,0	Y-924J	7906	1
Ducato 2.5 Di		2.5	85		03.94-	8140472200	11,5	Y-910J	3617	3

DUCATO 18

Ducato Maxi 2.5 TD		2.5	68	4	01.86-02.94	814421220	11,0	Y-924J	7906	1
--------------------	--	-----	----	---	-------------	-----------	------	--------	------	---

EGEA

FIAT Egea 1.3 JTD Multijet (For OE-No. 356SXB1A, 55238404)		1.3	70	4	10.15-	330A1000	4,3	Y9001AS	97719	72
Egea 1.6 Multijet	356	1.6	88	4	10.15-	955A3000	4,4	Y9003AS	94251	78





l kW C
Y
I



Stock-No
D-POWER

FIAT

FIORINO

Fiorino 1.3 D	159AC	1.3	33	4	06.90-08.93	146B1000	11,0	Y-924J	7906	1
FIAT Fiorino 1.3 JTD Multijet (For OE-No. 55238404)	225CXG1A	1.3	59	4	03.15-	225A2000	4,3	Y9001AS	97719	72
Fiorino 1.7 D		1.7	42	4	01.88-	149B4046	11,0	Y-924J	7906	1
Fiorino 1.7 D		1.7	43	4	12.87-	149B3000	11,0	Y-924J	7906	1
Fiorino 1.7	146RD	1.7	44	4	10.93-10.99	146B2000	11,0	Y-924J	7906	1
Fiorino 1.7 TD	146RH	1.7	46	4	11.96-05.01	146D7000	11,0	Y-924J	7906	1

FIORINO 225

Fiorino 1.3 JTD Multijet (Euro 5)	225	1.3	55	4	05.05-08.13	199A2000	4,3	Y9001AS	97719	72
Fiorino 1.3 JTD Multijet (Euro 4)	225	1.3	55	4	02.08-	199A2000	11,0	Y8003J	97256	62
Fiorino 1.3 JTD Multijet	225	1.3	70	4	07.09-	199B1000	4,3	Y9001AS	97719	72

FREEMONT

Freemont 2.0 JTDM	JC	2.0	100	4	08.11-	940A5000	4,4	Y9003AS	94251	78
Freemont 2.0 JTDM	JC	2.0	103	4	08.11-	940A5000	4,4	Y9003AS	94251	78
Freemont 2.0 JTDM	JC	2.0	120	4	08.11-	940A4000	4,4	Y9003AS	94251	78
Freemont 2.0 JTDM	JC	2.0	125	4	08.11-	940A4000, 939B5000	4,4	Y9003AS	94251	78

GRANDE PUNTO

Grande Punto 1.3 JTD Multijet	199	1.3	51	4	07.08-02.12	199B2000	11,0	Y8003J	97256	62
Grande Punto 1.3 JTD Multijet	199	1.3	55	4	09.05-	199A2000	11,0	Y8003J	97256	62
Grande Punto 1.3 JTD Multijet	199	1.3	62	4	04.10-12.12	223A9000	11,0	Y8003J	97256	62
Grande Punto 1.3 JTD Multijet	199	1.3	62	4	04.10-12.12	199B4000	4,3	Y9001AS	97719	72
Grande Punto 1.3 JTD Multijet	199	1.3	66	4	12.05-08.10	199A3000	11,0	Y8003J	97256	62
Grande Punto 1.6 Multijet DPF	199	1.6	88	4	01.08-12.09	955A3000	4,4	Y9003AS	94251	78
Grande Punto 1.9 JTD	199	1.9	85	4	06.06-12.12	939A7000	11,0	Y1030J	90828	70
Grande Punto 1.9 JTD	199	1.9	88	4	10.05-07.12	939A1000	11,0	Y1030J	90828	70
Grande Punto 1.9 JTD	199	1.9	96	4	10.05-12.12	199A5000	11,0	Y1030J	90828	70

IDEA

Idea 1.3 JTD	350	1.3	51	4	06.03-12.11	188A9000	11,0	Y8003J	97256	62
Idea 1.3 JTD Multijet	350	1.3	66	4	04.05-12.10	199A3000	11,0	Y8003J	97256	62
Idea 1.3 JTD Multijet (Euro 5)	350	1.3	68	4	04.09-12.12	199B1000	4,3	Y9001AS	97719	72
Idea 1.6 MJTD	350	1.6	88	4	07.08-12.12	350A2000	4,4	Y9003AS	94251	78
Idea 1.9 JTD	350	1.9	74	4	10.03-12.10	188B2000	11,0	Y-534J	3413	36

LINEA

Linea 1.3 JTD Multijet	323	1.3	70	4	09.09-	199A3000	4,3	Y9001AS	97719	72
Linea 1.6 JTD Multijet	323	1.6	77	4	06.09-	198A3000	4,4	Y9003AS	94251	78

MAREA / MARENCO

Marengo 1.9 D	185	1.9	48	4	01.92-	160A7000	11,0	Y-924J	7906	1
Marea 1.9 TD	185	1.9	55	4	09.96-12.00	182A8000	11,0	Y-928U	4389	29
Marengo 1.9 TD	185	1.9	66	4	01.92-	160A6000	11,0	Y-924J	7906	1
Marea 1.9 S.W. / Weekend JTD	185	1.9	74	4	08.96-06.03	182B9000	11,0	Y-534J	3413	36
Marea 1.9 TD/JTD	185	1.9	74	4	09.96-12.00	182A7000	11,0	Y-928U	4389	29
Marea / Marengo 1.9 JTD (Engine No->1713819)	185	1.9	77	4	04.99-11.99	182B4000	11,0	Y-747U	4694	26
Marea / Marengo 1.9 JTD (Engine No 1713820->)	185	1.9	77	4	12.99-01.01	182B4000	11,0	Y-534J	3413	36
Marea / Marengo 1.9 JTD	185	1.9	81	4	03.99-08.02	186A6000	11,0	Y-534J	3413	36
Marea 2.4 JTD	185	2.4	91	5	09.96-12.00	185A2000	11,0	Y-928U	4389	29





e kW C y i

Stock-No
D-POWER™**FIAT****MAREA / MARENCO**

Marea 2.4 JTD (Engine No→1713819)	185	2.4	100	5	03.99-11.99	185A6000	11,0	Y-747U	4694	26
Marea 2.4 JTD (Engine No 1713820→)	185	2.4	100	5	12.99-09.02	185A6000	11,0	Y-534J	3413	36

MULTIPLA

Multipia 1.9 JTD (Engine No→1692991)	186	1.9	77	4	11.98-11.99	182B4000	11,0	Y-747U	4694	26
Multipia 1.9 JTD (Engine No 1692992→)	186	1.9	77	4	12.99-02.01	182B4000	11,0	Y-534J	3413	36
Multipia 1.9 JTD	186	1.9	81	4	02.01-07.02	186A6000	11,0	Y-534J	3413	36
Multipia 1.9 JTD (Euro 3)	186	1.9	85	4	07.02-09.05	186A8000	11,0	Y-534J	3413	36
Multipia 1.9 JTD (Euro 4)	186	1.9	85	4	10.03-12.10	186A8000	11,0	Y1030J	90828	70
Multipia 1.9 JTD	186	1.9	88	4	04.02-06.10	186A9000	11,0	Y1030J	90828	70

NUOVO DOBLO

Doblò 1.3 JTD Multijet		1.3	66	4	02.10-	263A2000	4,3	Y9001AS	97719	72
------------------------	--	-----	----	---	--------	----------	-----	---------	-------	----

PALIO

Palio 1.7 TD	178	1.7	51	4	07.96-12.09	176A3000	11,0	Y-924J	7906	1
Palio 1.7 TD	178	1.7	53	4	09.01-01.12	176A5000	11,0	Y8003J	97256	62
Palio 1.9 D	178	1.9	46	4	.01-08.02	223A6000	11,0	Y-939J	5059	43

PANDA

Panda 1.3 JTD Multijet	169	1.3	51	4	12.03-12.12	188A8000	11,0	Y8003J	97256	62
Panda 1.3 JTD Multijet	169	1.3	51	4	08.04-12.12	188A8000	11,0	Y8003J	97256	62
Panda 1.3 JTD Multijet	169	1.3	55	4	06.06-12.12	169A5000	11,0	Y8003J	97256	62
Panda 1.3 JTD Multijet	312	1.3	59	4	06.14-	312A8000	4,3	Y9001AS	97719	72
FIAT Panda 1.3 JTD Multijet (For OE-No. 55238404)	312PXS2A	1.3	59	4	05.15-	225A2000	4,3	Y9001AS	97719	72
FIAT Panda 1.3 JTD Multijet (For OE-No. 55238404)	312PXS2A	1.3	59	4	05.15-	312B2000	4,3	Y9001AS	97719	72
FIAT Panda 1.3 JTD Multijet (For OE-No. 55238404)	312PXU1A, 312PXW1A	1.3	70	4	04.15-	312B1000	4,3	Y9001AS	97719	72
FIAT Panda 1.3 JTD Multijet (For OE-No. 55238404)	312PXU1A, 312PXW1A	1.3	70	4	04.15-	330A1000	4,3	Y9001AS	97719	72

PANDA MY03

Panda / Panda 4x4 1.3 JTD Multijet	169	1.3	51	4	09.03-12.12	188A8000	11,0	Y8003J	97256	62
Panda 1.3 JTD Multijet	169	1.3	51	4	09.03-12.12	188A9000	11,0	Y8003J	97256	62
Panda 1.3 JTD Multijet	169	1.3	55	4	07.06-12.12	169A1000	11,0	Y8003J	97256	62
Panda 1.3 JTD Multijet 4x4	169	1.3	55	4	01.10-12.12	169A1000	4,3	Y9001AS	97719	72

PANDA MY12

Panda 1.3 JTD Multijet	312	1.3	55	4	01.12-	169A1000, 169A9000	4,3	Y9001AS	97719	72
Panda 1.3 JTD Multijet 4x4	312	1.3	55	4	06.12-	199A9000	4,3	Y9001AS	97719	72

PRATICO

Pratico 1.6 D Multijet	263	1.6	77	4	02.10-	198A3000	4,4	Y9003AS	94251	78
Pratico 2.0 D Multijet	263	2.0	99	4	02.10-	263A1000	4,4	Y9003AS	94251	78

PUNTO 1

Punto 1 1.7 D	176	1.7	42	4	11.94-09.97	176B3000	11,0	Y-924J	7906	1
Punto 1 1.7 TD	176	1.7	51	4	06.93-09.96	176A3000	11,0	Y-924J	7906	1
Punto 1 1.7 TD	176	1.7	52	4	10.96-12.99	176A5000	11,0	Y-924J	7906	1

PUNTO 2

Punto 2 1.3 JTD Multijet	188	1.3	51	4	12.03-10.09	188A9000	11,0	Y8003J	97256	62
Punto 2 1.9 D	188	1.9	44	4	09.99-10.03	188A3000	11,0	Y-939J	5059	43
Punto 2 1.9 JTD	188	1.9	59	4	10.99-12.00	188A2000	11,0	Y-534J	3413	36
Punto 2 1.9 JTD	188	1.9	63	4	01.01-06.03	188A7000	11,0	Y-534J	3413	36





e kW C
Y
I



Stock-No
D-POWER

FIAT

PUNTO 2

Punto 2 1.9 JTD	188	1.9	63	4	07.03-10.05	188A7000	11,0	Y1030J	90828	70
Punto 2 1.9 MJTD	188	1.9	74	4	07.03-06.05	188B2000	11,0	Y1030J	90828	70

PUNTO 3

Punto 3 1.3 JTD Multijet (Euro 4)	199	1.3	55	4	03.12-	199A2000	11,0	Y8003J	97256	62
Punto 3 1.3 JTD Multijet (Euro 4)	199	1.3	55	4	03.12-	199A9000	11,0	Y8003J	97256	62
Punto 3 1.3 JTD Multijet (Euro 5)	199	1.3	55	4	03.12-	199A2000, 199A9000	4,3	Y9001AS	97719	72
Punto 3 1.3 JTD Multijet	199	1.3	59	4	12.13-	199B8000	4,3	Y9001AS	97719	72
Punto 3 1.3 JTD Multijet (Euro 4)	199	1.3	62	4	03.12-	199B4000	11,0	Y8003J	97256	62
Punto 3 1.3 JTD Multijet (Euro 5)	199	1.3	62	4	03.12-	199B4000	4,3	Y9001AS	97719	72
Punto 3 1.3 JTD Multijet (For OE-No. 46796050; Euro 4)	199	1.3	70	4	03.12-	199B1000	11,0	Y8003J	97256	62
FIAT Punto 1.3 JTD Multijet (For OE-No. 55238404)	199AXU1A, 199BXU1A	1.3	70	4	03.12-	330A1000	4,3	Y9001AS	97719	72
FIAT Punto 1.3 JTD Multijet (For OE-No. 55238404 / 55210051)	199AXU1A, 199BXU1A	1.3	70	4	03.12-	199B1000	4,3	Y9001AS	97719	72
Punto 3 1.6 Multijet	199	1.6	88	4	01.08-12.09	955A3000	4,4	Y9003AS	94251	78

PUNTO EVO

Punto EVO 1.3 JTD Multijet	199	1.3	51	4	10.09-02.12	199B2000	4,3	Y9001AS	97719	72
Punto EVO 1.3 JTD Multijet (Euro 4)	199	1.3	55	4	06.09-02.12	199A2000	11,0	Y8003J	97256	62
Punto EVO 1.3 JTD Multijet (Euro 5)	199	1.3	55	4	06.09-02.12	199A9000	4,3	Y9001AS	97719	72
Punto EVO 1.3 JTD Multijet	199	1.3	62	4	10.09-02.12	199B4000	4,3	Y9001AS	97719	72
Punto EVO 1.3 JTD Multijet	199	1.3	62	4	10.09-02.12	223A9000	4,3	Y9001AS	97719	72
Punto EVO 1.3 JTD Multijet	199	1.3	66	4	06.09-02.12	199A3000	11,0	Y8003J	97256	62
Punto EVO 1.3 JTD Multijet	199	1.3	70	4	06.09-02.12	199B1000	4,3	Y9001AS	97719	72
Punto EVO 1.6 Multijet	199	1.6	88	4	09.09-02.12	955A3000	4,4	Y9003AS	94251	78

QUBO

Qubo 1.3 JTD Multijet (Euro 4)	225	1.3	55	4	09.08-	199A2000	11,0	Y8003J	97256	62
Qubo 1.3 JTD Multijet (Euro 5)	225	1.3	55	4	09.08-	199A2000	4,3	Y9001AS	97719	72
FIAT Qubo 1.3 JTD Multijet (For OE-No. 55238404)	225AXG11, 225AXG1A, 225CXG11, 225CXG1A	1.3	59	4	03.15-	225A2000	4,3	Y9001AS	97719	72
Qubo 1.3 JTD Multijet	225	1.3	70	4	11.09-	199B1000	4,3	Y9001AS	97719	72

SCUDO

Scudo 1.6 Multijet	270XXA1A	1.6	66	4	11.06-03.16	9HU	11,0	YE05	91322	73
Scudo 1.9 D	220	1.9	51	4	03.96-07.98	D9B	11,0	Y-924J	7906	1
Scudo 1.9	220	1.9	51	4	09.98-10.06	DW8	11,0	Y-503J	1009	10
Scudo 1.9 TD	220	1.9	68	4	03.96-10.06	D8B	11,0	Y-924J	7906	1
Scudo 1.9	220	1.9		4	09.98-10.06	WJY	11,0	Y-503J	1009	10
Scudo 2.0 JTD	220	2.0	69	4	09.99-10.06	RHX	11,0	Y-504J	1441	24
Scudo 2.0 JTD	220YP5A	2.0	69	4	09.99-10.06	RHX	11,0	Y-504J	1441	24
Scudo 2.0 JTD	220YR5, 220YR5L	2.0	80	4	09.00-10.06	RHW	11,0	Y-504J	1441	24
Scudo 2.0 JTD	220ZV5RBX	2.0	80	4	12.02-12.06	RHZ	11,0	Y-504J	1441	24
Scudo 2.0 JTD	220	2.0	81	4	05.99-05.03	RHM	11,0	Y-504J	1441	24
Scudo 2.0 JTD	220	2.0	81	4	05.99-05.03	RHW	11,0	Y-504J	1441	24
Scudo 2.0 JTD	220	2.0	81	4	06.03-12.06	RHM	11,0	Y1005J	7957	56
Scudo 2.0	270	2.0	88	4	11.06-	RHG	11,0	Y1005J	7957	56
Scudo 2.0 Multijet		2.0	88	4	11.06-	RHK	11,0	Y1005J	7957	56





l kW C
y i



Stock-No
D-POWER™

FIAT

SCUDO

Scudo 2.0 Multijet	270	2.0	94	4	05.11-	RH02	11,0	Y1005J	7957	56
Scudo 2.0 Multijet		2.0	100	4	11.06-	RHR	11,0	Y1005J	7957	56
Scudo 2.0 Multijet	270	2.0	120	4	07.10-	RHH	11,0	Y1005J	7957	56

SEDICI

Sedici 1.9 JTD	189	1.9	88	4	01.06-	D19AA	11,0	Y-534J	3413	36
Sedici 2.0 MJTD	189	2.0	99	4	09.09-	D20AA	4,4	Y9003AS	94251	78

STILO

Stilo 1.9 JTD	192	1.9	59	4	09.01-08.04	192A3000	11,0	Y-534J	3413	36
Stilo 1.9 JTD	192	1.9	66	4	09.04-12.10	192B5000	11,0	Y1030J	90828	70
Stilo 1.9 JTD	192	1.9	74	4	09.04-07.05	192A9000	11,0	Y-534J	3413	36
Stilo 1.9 JTD	192	1.9	85	4	10.01-12.07	192A1000	11,0	Y-534J	3413	36
Stilo 1.9 JTD	192	1.9	85	4	07.05-12.07	937A7000	11,0	Y1030J	90828	70
Stilo 1.9 JTD	192	1.9	88	4	09.05-08.08	192A8000	11,0	Y1030J	90828	70
Stilo 1.9 JTD	192	1.9	93	4	09.03-11.06	937A4000	11,0	YE07	6092	
Stilo 1.9 JTD	192	1.9	100	4	04.04-11.06	192B1000	11,0	YE07	6092	
Stilo 1.9 JTD	192	1.9	103	4	01.04-09.05	192A5000	11,0	YE07	6092	
Stilo 1.9 JTD	192	1.9	110	4	09.05-08.08	937A5000	11,0	YE07	6092	

STRADA

Strada 1.3 Multijet	178	1.3	63	4	05.06-	223A9000	11,0	Y8003J	97256	62
Strada 1.3 Multijet	278	1.3	70	4	10.10-	199B1000	4,3	Y9001AS	97719	72
Strada 1.7 TDs	178	1.7	51	4	06.99-	176A3000	11,0	Y-924J	7906	1
Strada 1.9 D	178	1.9	46	4	12.00-03.03	223A6000	11,0	Y-939J	5059	43
Strada 1.9 JTD	178	1.9	59	4	04.03-06.05	188A2000	11,0	Y-534J	3413	36

TALENTO

Talento 1.9 D		1.9	51	4	03.88-	149B1000	11,0	Y-924J	7906	1
---------------	--	-----	----	---	--------	----------	------	--------	------	---

TEMPRA

Tempra 1.9 TD /SW	159	1.9	48	4	02.90-06.96	160A7000	11,0	Y-924J	7906	1
Tempra 1.9 TD	159	1.9	59	4	07.90-07.96	160B6046	11,0	Y-924J	7906	1
Tempra 1.9 TD	159	1.9	59	4	05.92-07.96	160B6046	11,0	Y-924J	7906	1
Tempra 1.9 TD /SW	159	1.9	66	4	02.90-07.96	160A6000	11,0	Y-924J	7906	1
Tempra 1.9 TD	159	1.9	68	4	06.93-09.96	160D1000	11,0	Y-924J	7906	1

TIPO

FIAT Tipo 1.3 JTD Multijet (For OE-No. 55238404)	356SXB1A, 356SXH1A	1.3	70	4	10.15-	199B1000	4,3	Y9001AS	97719	72
FIAT Tipo 1.3 JTD Multijet (For OE-No. 55238404)	356SXB1A, 356SXH1A, 356HXH1A, 356WXH1A	1.3	70	4	10.15-	55266963	4,3	Y9001AS	97719	72
FIAT Tipo 1.3 JTD Multijet (For OE-No. 55238404)	356SXB1A, 356SXH1A, 356WXH1A	1.3	70	4	10.15-	55283775	4,3	Y9001AS	97719	72
Tipo 1.6 Multijet	356	1.6	88	4	01.16-	955A3000	4,4	Y9003AS	94251	78
Tipo 1.7 D	160	1.7	42	4	07.87-03.93	149B4000	11,0	Y-924J	7906	1
Tipo 1.9 D	160	1.9	48	4	07.89-03.93	149A1000	11,0	Y-924J	7906	1
Tipo 1.9 TD	160	1.9	66	4	07.87-	160D1000	11,0	Y-924J	7906	1
Tipo 1.9 TD	160	1.9	68	4	07.87-03.93	149A1000	11,0	Y-924J	7906	1

ULYSSE

Ulysse 1.9 TD	220	1.9	68	4	05.97-12.99	D8B	11,0	Y-924J	7906	1
---------------	-----	-----	----	---	-------------	-----	------	--------	------	---





e kW C
y
i



Stock-No
D-POWER

FIAT

ULYSSE

Ulysse 2.0 JTD	179	2.0	79	4	06.03-08.06	RHM(DW10ATED4)	11,0	Y1005J	7957	56
Ulysse 2.0 JTD	179	2.0	80	4	09.02-	DW10ATED4, RHT	11,0	Y-504J	1441	24
Ulysse 2.0 JTD (VIN→9666)	179	2.0	80	4	09.02-05.03	RHW(DW10ATED4)	11,0	Y-504J	1441	24
Ulysse 2.0 JTD (VIN 9667→)	179	2.0	80	4	06.03-11.06	RHW(DW10ATED4)	11,0	Y1005J	7957	56
Ulysse 2.0 JTD	179	2.0	80	4	06.03-08.06	RHM	11,0	Y1005J	7957	56
Ulysse 2.0 Multijet	179	2.0	88	4	05.06-03.10	RHK	11,0	Y1005J	7957	56
Ulysse 2.0 Multijet	179	2.0	100	4	05.06-	RHR	11,0	Y1005J	7957	56
Ulysse 2.2 JTD	179BXC1A, 179BXM1B	2.2	94	4	08.02-05.03	4HW	11,0	Y-504J	1441	24
Ulysse 2.2 JTD (VIN→9666)	179	2.2	94	4	09.02-05.03	4HW(DW12ATED4)	11,0	Y-504J	1441	24
Ulysse 2.2 JTD (VIN 9667→)	179	2.2	94	4	06.03- .06	4HW(DW12ATED4)	11,0	Y1005J	7957	56
Ulysse 2.2 JTD	179	2.2	96	4	06.02-07.07	4H01	11,0	Y1005J	7957	56
Ulysse 2.2 JTD	179	2.2	120	4	03.08-03.10	4HP	11,0	YE08	4966	
Ulysse 2.2 JTD	179	2.2	120	4	03.08-03.10	4HR	11,0	YE08	4966	
Ulysse 2.2 JTD	179	2.2	125	4	02.08-03.10	4HT, DW12BTED4	11,0	YE08	4966	

UNO

Uno 60 TD	1.4	51	4	03.86-09.92	146B	11,0	Y-924J	7906	1
Uno TD	1.4	52	4	09.89-12.95	146B3000	11,0	Y-924J	7906	1
Uno 60 D	1.7	40	4	09.89-09.92	146B2000	11,0	Y-924J	7906	1
Uno D Van	1.7	42	4	09.89-03.96	146B2000	11,0	Y-924J	7906	1

FORD

B-MAX

B-Max 1.5 TDCi	JK	1.5	55	4	10.12-	UGJC	5,0	Y8001AS	8904	58
B-Max 1.6 TDCi	JK	1.6	70	4	10.12-	T3JB	5,0	Y8001AS	8904	58

C-MAX 11

C-Max 11 1.6 TDCi (Euro 5)	BJ	1.6	70	4	12.10-	T3DA, T3DB	5,0	Y8001AS	8904	58
C-Max 11 1.6 TDCi (Euro 5)	BJ	1.6	85	4	12.10-	T1DA, T1DB	5,0	Y8001AS	8904	58
C-Max 11 2.0 TDCi (Euro 5)	BJ	2.0	85	4	02.11-	TYDA	5,0	Y8001AS	8904	58
C-Max 11 2.0 TDCi (Euro 5)	BJ	2.0	100	4	02.11-	UKDB	5,0	Y8001AS	8904	58
C-Max 11 2.0 TDCi (Euro 5)	BJ	2.0	103	4	02.11-	UFDB	5,0	Y8001AS	8904	58
C-Max 11 2.0 TDCi (Euro 5)	BJ	2.0	120	4	12.10-	TXDB	5,0	Y8001AS	8904	58

COURIER

Courier D	1.8	66	4	03.93-		11,5	Y-910J	3617	3
-----------	-----	----	---	--------	--	------	--------	------	---

ESCORT '91

Escort '91	1.8	44	4	08.90-09.01	RTE	11,5	Y-910J	3617	3
Escort '91	1.8	44	4	08.90-09.01	RTF	11,5	Y-910J	3617	3
Escort '91	1.8	44	4	08.90-09.01	RTH	11,5	Y-910J	3617	3
Escort '91 TD	1.8	51	4	08.90-09.01	RVA Endura-DE (TC)	10,0	Y-937J	7503	5
Escort '91	1.8	66	4	08.90-09.01	RFD	11,5	Y-910J	3617	3
Escort '91	1.8	66	4	08.90-09.01	RFK	11,5	Y-910J	3617	3
Escort '91	1.8	66	4	08.90-09.01	RFS Endura-DE (TC)	10,0	Y-937J	7503	5

FIESTA '01

Fiesta '01 TDCI	1.4	50	4	11.01-12.04	F6JA DuraTorq-TDCi	11,0	YE04	1684	40
Fiesta '01 TDCI	1.4	50	4	11.01-12.04	F6JB DuraTorq-TDCi	11,0	YE04	1684	40
Fiesta '01 TDCI	1.4	50	4	01.05-	F6JA DuraTorq-TDCi	11,0	YE05	91322	73





l kW C
y
i



Stock-No
D-POWER™

FORD

FIESTA '01

Fiesta '01 TDCi	1.4	50	4	01.05-	F6JB DuraTorq-TDCi	11,0	YE05	91322	73
Fiesta '01 TDCi	1.6	66	4	03.05-	HHJA DuraTorq-TDCi	11,0	YE04	1684	40
Fiesta '01 TDCi	1.6	66	4	03.05-	HHJB DuraTorq-TDCi	11,0	YE04	1684	40

FIESTA '08

Fiesta '08 1.4 TDCi	1.4	50	4	08.08-	F6JB	11,0	YE05	91322	73
Fiesta '08 1.4 TDCi	1.4	51	4	07.10-	F6JD, KVJA	11,0	YE05	91322	73
Fiesta '08 1.5 TDCi	1.5	55	4	09.12-	UGJC	5,0	Y8001AS	8904	58
Fiesta '08 1.6 TDCi	1.6	55	4	08.08-	HHJF, UBJA	11,0	YE05	91322	73
Fiesta '08 1.6 TDCi	1.6	66	4	08.08-	HHJC, HHJD	11,0	YE05	91322	73
Fiesta '08 1.6 TDCi (Euro 5)	1.6	70	4	03.10-	TZJA, TZJB, T3JA	5,0	Y8001AS	8904	58

FIESTA '89

Fiesta '89	1.8	44	4	03.89-06.96	RTC, RTD, RTG	11,5	Y-910J	3617	3
Fiesta '89	1.8	44	4	03.89-06.96	RTD D	11,5	Y-910J	3617	3
Fiesta '89	1.8	44	4	03.89-06.96	RTG D	11,5	Y-910J	3617	3

FIESTA '96

Fiesta '96	1.8	44	4	11.95-02.02	RTJ	10,0	Y-937J	7503	5
Fiesta '96	1.8	44	4	11.95-02.02	RTK	10,0	Y-937J	7503	5
Fiesta '96	1.8	55	4	11.95-02.02	RTN	10,0	Y-524J	4520	27
Fiesta '96	1.8	55	4	11.95-02.02	RTP	10,0	Y-524J	4520	27
Fiesta '96	1.8	55	4	11.95-02.02	RTQ	10,0	Y-524J	4520	27

FOCUS '02

Focus / C-Max 1.6 TDCi	1.6	66	4	06.03-05.06	HHDA, HHDB	11,0	YE04	1684	40
Focus / C-Max 1.6 TDCi	1.6	66	4	06.06-	HHDA, HHDB	11,0	YE05	91322	73
Focus / C-Max 1.6 TDCi	1.6	80	4	06.03-05.06	G8DA, G8DB	11,0	YE04	1684	40
Focus / C-Max 1.6 TDCi	1.6	80	4	06.06-	G8DA, G8DB	11,0	YE05	91322	73
Focus / C-Max TDCi	2.0	98	4	06.03-	G6DC DuraTorq-TDCi	11,0	Y1005J	7957	56
Focus / C-Max TDCi	2.0	98	4	06.03-	G6DE DuraTorq-TDCi	11,0	Y1005J	7957	56
Focus / C-Max TDCi	2.0	98	4	06.03-	G6DF DuraTorq-TDCi	11,0	Y1005J	7957	56
Focus / C-Max TDCi	2.0	100	4	06.03-	G6DA	11,0	Y1005J	7957	56
Focus / C-Max TDCi	2.0	100	4	06.03-	G6DB	11,0	Y1005J	7957	56
Focus / C-Max TDCi	2.0	100	4	06.03-	G6DD	11,0	Y1005J	7957	56
Focus C-Max TDCi	2.0	100	4	10.03-08.07	G6DA	11,0	Y1005J	7957	56
Focus C-Max TDCi	2.0	100	4	10.03-08.07	G6DB	11,0	Y1005J	7957	56
Focus C-Max TDCi	2.0	100	4	10.03-08.07	G6DD	11,0	Y1005J	7957	56

FOCUS '04

Focus '04 1.6 TDCi	1.6	66	4	07.04-05.06	HHDA, HHDB	11,0	YE04	1684	40
Focus '04 1.6 TDCi	1.6	66	4	06.06-	HHDA, HHDB	11,0	YE05	91322	73
Focus '04 1.6 TDCi	1.6	80	4	07.04-05.06	G8DA, G8DB	11,0	YE04	1684	40
Focus '04 1.6 TDCi	1.6	80	4	06.06-	G8DA, G8DB	11,0	YE05	91322	73
Focus '04 1.8 TDCi	1.8	85	4	07.04-	KKDA, KKDB	10,0	Y-524J	4520	27
Focus '04 2.0 TDCi	2.0	81	4	02.08-	IXDA	11,0	Y1005J	7957	56
Focus '04 2.0 TDCi	2.0	98	4	07.04-	G6DC DuraTorq-TDCi	11,0	Y1005J	7957	56
Focus '04 2.0 TDCi	2.0	98	4	07.04-	G6DE DuraTorq-TDCi	11,0	Y1005J	7957	56
Focus '04 2.0 TDCi	2.0	98	4	07.04-	G6DF DuraTorq-TDCi	11,0	Y1005J	7957	56
Focus '04 2.0 TDCi	2.0	100	4	07.04-	G6DA	11,0	Y1005J	7957	56





l kW C
Y
I



Stock-No
D-POWER

FORD

FOCUS '04

Focus '04 2.0 TDCi	2.0	100	4	07.04-	G6DB	11,0	Y1005J	7957	56
Focus '04 2.0 TDCi	2.0	100	4	07.04-	G6DD	11,0	Y1005J	7957	56

FOCUS '11

Focus 11 1.6 TDCi (Euro 5)	1.6	70	4	04.11-	T3DA, T3DB	5,0	Y8001AS	8904	58
Focus 11 1.6 TDCi ECONetic	1.6	77	4	05.12-	NGDA	5,0	Y8001AS	8904	58
Focus 11 1.6 TDCi (Euro 5)	1.6	85	4	04.11-	T1DA, T1DB	5,0	Y8001AS	8904	58
Focus 11 2.0 TDCi (Euro 5)	2.0	85	4	04.11-	TYDA	5,0	Y8001AS	8904	58
Focus 11 2.0 TDCi (Euro 5)	2.0	100	4	04.11-	UKDB	5,0	Y8001AS	8904	58
Focus 11 2.0 TDCi (Euro 5)	2.0	103	4	04.11-	UFDB	5,0	Y8001AS	8904	58
Focus 11 2.0 TDCi (Euro 5)	2.0	120	4	04.11-	TXDB	5,0	Y8001AS	8904	58

FOCUS '18

Focus ,18 1.5 EcoBlue	HN, HM, HP	1.5	70	4	01.18-	Z2DA	5,0	Y8012AS	93065
Focus ,18 1.5 EcoBlue	HN, HM, HP	1.5	88	4	01.18-	ZTDA	5,0	Y8012AS	93065
Focus ,18 1.5 EcoBlue	HN, HM, HP	1.5	88	4	01.18-	ZTDB	5,0	Y8012AS	93065

FOCUS '98

Focus '98	1.8	55	4	08.98-12.04	BHDA Endura-DI	10,0	Y-524J	4520	27
Focus '98	1.8	55	4	08.98-12.04	BHDB Endura-DI	10,0	Y-524J	4520	27
Focus '98	1.8	66	4	08.98-12.04	C9DA Endura-DI	10,0	Y-524J	4520	27
Focus '98	1.8	66	4	08.98-12.04	C9DB Endura-DI	10,0	Y-524J	4520	27
Focus '98 Turbo Di	1.8	66	4	08.98-12.04	C9DC Endura-DI	10,0	Y-524J	4520	27
Focus '98	1.8	74	4	08.98-12.04	FFDA DuraTorq-TDCi	10,0	Y-524J	4520	27
Focus '98	1.8	85	4	08.98-12.04	F9DB DuraTorq-TDCi	10,0	Y-524J	4520	27
Focus '98 TDCi	1.8	85	4	08.98-12.04	F9DA DuraTorq-TDCi	10,0	Y-524J	4520	27

FUSION

Fusion TDCi	1.4	50	4	06.02-12.04	F6JA DuraTorq-TDCi	11,0	YE04	1684	40
Fusion TDCi	1.4	50	4	06.02-12.04	F6JB DuraTorq-TDCi	11,0	YE04	1684	40
Fusion TDCi	1.4	50	4	01.05-	F6JA DuraTorq-TDCi	11,0	YE05	91322	73
Fusion TDCi	1.4	50	4	01.05-	F6JB DuraTorq-TDCi	11,0	YE05	91322	73
Fusion TDCi	1.6	66	4	06.02-	HHJA DuraTorq-TDCi	11,0	YE04	1684	40
Fusion TDCi	1.6	66	4	06.02-	HHJB DuraTorq-TDCi	11,0	YE04	1684	40

GALAXY '95

Galaxy TDI	1.9	66	4	02.95-02.96	1Z	12,0	Y-732J	5605	4
Galaxy TDI	1.9	66	4	02.95-03.00	ANU	12,0	Y-732J	5605	4
Galaxy TDI	1.9	66	4	03.96-03.00	1Z	12,0	Y-732J	5605	4
Galaxy TDI	1.9	66	4	09.96-03.00	AHU	12,0	Y-732J	5605	4
Galaxy TDI	1.9	81	4	02.95-08.99	AFN	12,0	Y-732J	5605	4
Galaxy TDI	1.9	81	4	02.95-08.99	ANF	12,0	Y-732J	5605	4
Galaxy TDI	1.9	81	4	09.99-03.00	AVG	12,0	Y-732J	5605	4
Galaxy TDI	1.9		4	06.95-	AJM	12,0	Y-732J	5605	4

GALAXY 06

Galaxy 06 1.6 TDCi (Euro 5)	WM	1.6	85	4	02.11-	T1WA, T1WB	5,0	Y8001AS	8904	58
Galaxy 06 1.8 TDCi	WM	1.8	74	4	05.06-	FFWA	10,0	Y-524J	4520	27
Galaxy 06 2.0 TDCi	WM	2.0	85	4	11.07-	KLWA	11,0	Y1005J	7957	56
Galaxy 06 2.0 TDCi	WM	2.0	85	4	11.07-	TYWA	5,0	Y8001AS	8904	58
Galaxy 06 2.0 TDCi	WM	2.0	96	4	05.06-	AZWA	11,0	Y1005J	7957	56





e kW C
y
i



Stock-No
D-POWER™

FORD

GALAXY 06

Galaxy 06 2.0 TDCi	WM	2.0	100	4	04.06-	AZWC, UKWA	5,0	Y8001AS	8904	58
Galaxy 06 2.0 TDCi	WM	2.0	103	4	05.06-	QXWA, QXWB, QXWC	11,0	Y1005J	7957	56
Galaxy 06 2.0 TDCi	WM	2.0	103	4	05.06-	UFWA	5,0	Y8001AS	8904	58
Galaxy 06 2.0 TDCi (Euro 5)	WM	2.0	120	4	03.10-	TXWA	5,0	Y8001AS	8904	58
Galaxy 06 2.2 TDCi	WM	2.2	129	4	03.08-	Q4BA, Q4WA	11,0	YE08	4966	
Galaxy 06 2.2 TDCi	WM	2.2	147	4	07.10-		11,0	YE08	4966	

GALAXY 2000.75

Galaxy /2 TDI		1.9	66	4	04.00-02.06	ANU	12,0	Y-732J	5605	4
Galaxy /2 TDI		1.9	85	4	04.00-02.06	AUY	12,0	Y-732J	5605	4
Galaxy /2 TDI		1.9	96	4	04.00-02.06	ASZ	12,0	Y-732J	5605	4
Galaxy /2 TDI		1.9	96	4	04.00-02.06	AZS	12,0	Y-732J	5605	4
Galaxy /2 TDI		1.9	110	4	04.00-02.06	BTB	12,0	Y-732J	5605	4

GRANADA '85

Granada '85		2.5	51	4	05.85-10.94	STR D	11,0	Y-924J	7906	1
Granada '85		2.5	68	4	05.85-10.94	SFA D TURBO	11,0	Y-924J	7906	1
Granada '85		2.5	68	4	05.85-10.94	SFB D TURBO	11,0	Y-924J	7906	1

GRAND C-MAX 11

Grand C-Max 11 1.6 TDCi (Euro 5)	BH	1.6	70	4	12.10-	T3DA, T3DB	5,0	Y8001AS	8904	58
Grand C-Max 11 1.6 TDCi (Euro 5)	BH	1.6	85	4	12.10-	T1DA, T1DB	5,0	Y8001AS	8904	58
Grand C-Max 11 2.0 TDCi (Euro 5)	BH	2.0	85	4	02.11-	TYDA	5,0	Y8001AS	8904	58
Grand C-Max 11 2.0 TDCi (Euro 5)	BH	2.0	100	4	02.11-	UKDB	5,0	Y8001AS	8904	58
Grand C-Max 11 2.0 TDCi (Euro 5)	BH	2.0	103	4	02.11-	UFDB	5,0	Y8001AS	8904	58
Grand C-Max 11 2.0 TDCi (Euro 5)	BH	2.0	120	4	12.10-	TXDB	5,0	Y8001AS	8904	58

KA '08

Ka '08 1.3 TDCi	JDU	1.3	55	4	09.08-10.10	FD4	11,0	Y8003J	97256	62
Ka '08 1.3 TDCi	JDU	1.3	55	4	11.10-	FD4	4,3	Y9001AS	97719	72

KUGA I

Kuga I 2.0 TDCi	DR	2.0	100	4	03.08-	G6DG, UKDA	11,0	Y1005J	7957	56
Kuga I 2.0 TDCi (Euro 5)	DR	2.0	103	4	03.10-	UFDA	5,0	Y8001AS	8904	58
Kuga I 2.0 TDCi	DR	2.0	120	4	03.10-	TXDA	11,0	Y1005J	7957	56

KUGA II

Kuga II 2.0 TDCi	MA	2.0	100	4	11.12-	UKMA	5,0	Y8001AS	8904	58
Kuga II 2.0 TDCi	MA	2.0	103	4	11.12-	UFMA	5,0	Y8001AS	8904	58
Kuga II 2.0 TDCi	MA	2.0	120	4	11.12-	TXMA	5,0	Y8001AS	8904	58

MAVERICK '93

Maverick '93 2.7 TD		2.7	74	4	04.93-04.98	TD27	11,0	Y-712RS	6140	
Maverick '93 2.7 TD		2.7	92	4	05.96-04.98	TD27E	11,0	CZ261	97009	

MONDEO I (1993)

Mondeo I 1.8 TD		1.8	65	4	01.93-07.96	RFM D TCI	11,5	Y-910J	3617	3
Mondeo I 1.8 TD		1.8	65	4	01.93-07.96	RFN D TCI	11,5	Y-910J	3617	3

MONDEO II (1997)

Mondeo II 1.8 TD		1.8	66	4	08.96-09.00	RFN Endura-De TCI	10,0	Y-937J	7503	5
------------------	--	-----	----	---	-------------	-------------------	------	--------	------	---

MONDEO III (2001)

Mondeo III 2.0 TDCi		2.0	66	4	10.00-02.07	D5BA DuraTorq-DI	11,5	Y-548J	94832	75
Mondeo III 2.0 TDCi		2.0	85	4	10.00-02.07	D6BA DuraTorq-DI	11,5	Y-548J	94832	75





l kW C
Y
I



Stock-No
D-POWER

FORD

MONDEO III (2001)

Mondeo III 2.0 TDCi	2.0	85	4	10.00-02.07	HJBA DuraTorq-TDCi	11,5	Y-548J	94832	75
Mondeo III 2.0 TDCi	2.0	85	4	10.00-02.07	HJBB DuraTorq-TDCi	11,5	Y-548J	94832	75
Mondeo III 2.0 TDCi	2.0	85	4	10.00-02.07	HJBC DuraTorq-TDCi	11,5	Y-548J	94832	75
Mondeo III 2.0 TDCi	2.0	85	4	10.00-02.07	SDBA DuraTorq-TDCi	11,5	Y-548J	94832	75
Mondeo III 2.0 TDCi	2.0	96	4	10.00-02.07	FMBA DuraTorq-TDCi	11,5	Y-548J	94832	75
Mondeo III 2.0 TDCi	2.0	96	4	10.00-02.07	N7BA DuraTorq-TDCi	11,5	Y-548J	94832	75
Mondeo III 2.2 TDCi	2.2	110	4	09.04-02.07	QJBC DuraTorq-TDCi	11,5	Y-548J	94832	75
Mondeo III 2.2 TDCi	2.2	110	4	09.04-02.07	QJBD DuraTorq-TDCi	11,5	Y-548J	94832	75
Mondeo III 2.2 TDCi	2.2	114	4	09.04-02.07	QJBA DuraTorq-TDCi	11,5	Y-548J	94832	75
Mondeo III 2.2 TDCi	2.2	114	4	09.04-02.07	QJBB DuraTorq-TDCi	11,5	Y-548J	94832	75

MONDEO IV (2007)

Mondeo IV 1.6 TDCi (Euro 5)	1.6	85	4	11.10-05.14	T1BA, T1BB, T1BC	5,0	Y8001AS	8904	58
Mondeo IV 1.8 TDCi	1.8	74	4	02.07-05.14	FFBA DuraTorq-TDCi	10,0	Y-524J	4520	27
Mondeo IV 1.8 TDCi	1.8	92	4	02.07-05.14	KHBA DuraTorq-TDCi	10,0	Y-524J	4520	27
Mondeo IV 1.8 TDCi	1.8	92	4	02.07-05.14	QYBA DuraTorq-TDCi	10,0	Y-524J	4520	27
Mondeo IV 2.0 TDCi	2.0	85	4	02.07-05.14	KLBA, LPBA, TYBA	11,0	Y1005J	7957	56
Mondeo IV 2.0 TDCi	2.0	96	4	02.07-05.14	AZBA	11,0	Y1005J	7957	56
Mondeo IV 2.0 TDCi	2.0	96	4	02.07-05.14	N7DD	11,0	Y1005J	7957	56
Mondeo IV 2.0 TDCi	2.0	100	4	03.07-05.14	AZBC	11,0	Y1005J	7957	56
Mondeo IV 2.0 TDCi	2.0	103	4	02.07-05.14	QXBB, UFBA	11,0	Y1005J	7957	56
Mondeo IV 2.0 TDCi (Euro 5)	2.0	120	4	03.10-05.14	TXBA	5,0	Y8001AS	8904	58
Mondeo IV 2.2 TDCi	2.2	129	4	03.08-10.10	Q4BA	11,0	YE08	4966	

MONDEO V

Mondeo V 1.6 TDCi	DYK, DYL	1.6	85	4	09.14-	NGCA	5,0	Y8001AS	8904	58
Mondeo V 2.0 TDCi	DYK, DYL	2.0	110	4	09.14-	T7CC	5,0	Y8001AS	8904	58
Mondeo V 2.0 TDCi	DYK, DYL	2.0	132	4	09.14-	T8CC	5,0	Y8001AS	8904	58

ORION '91

Orion '91	1.8	44	4	08.90-07.93	RTE	11,5	Y-910J	3617	3
Orion '91	1.8	44	4	08.90-07.93	RTF	11,5	Y-910J	3617	3
Orion '91	1.8	44	4	08.90-07.93	RTH	11,5	Y-910J	3617	3
Orion '91	1.8	66	4	08.90-07.93	RFD	11,5	Y-910J	3617	3
Orion '91	1.8	66	4	08.90-07.93	RFK	11,5	Y-910J	3617	3

SCORPIO '85

Scorpio '85 2.5 D	2.5	51	4	05.85-10.94	STR D	11,0	Y-924J	7906	1
Scorpio '85 2.5 TD	2.5	68	4	05.85-10.94	SFA D TURBO	11,0	Y-924J	7906	1
Scorpio '85 2.5 TD	2.5	68	4	05.85-10.94	SFB D TURBO	11,0	Y-924J	7906	1
Scorpio '85 2.5 TD	2.5		4	11.94-07.98	SCB	11,0	Y-741U	6943	20

SCORPIO '95

Scorpio '95 2.5 TD	2.5	85	4	10.94-06.98	SCC TCI	11,0	Y-741U	6943	20
Scorpio '95 2.5 TD	2.5	92	4	10.94-06.98	SCD TCI	11,0	Y-741U	6943	20

SIERRA '87

Sierra '87 1.8 TD	1.8	55	4	01.87-12.92	RFA	11,5	Y-910J	3617	3
Sierra '87 1.8 TD	1.8	55	4	01.87-12.92	RFB	11,5	Y-910J	3617	3
Sierra '87 1.8 TD	1.8	55	4	01.87-12.92	RFL	11,5	Y-910J	3617	3
Sierra '87 2.3 D	2.3	49	4	01.87-12.92	YTR	11,0	Y-924J	7906	1





e kW C
y
i



Stock-No
D-POWER™

FORD

S-MAX

S-MAX 1.6 TDCi (Euro 5)	WS	1.6	85	4	02.11-	T1WA, T1WB	5,0	Y8001AS	8904	58
S-MAX 1.8 TDCi	WS	1.8	74	4	03.06-	FFWA	10,0	Y-524J	4520	27
S-MAX 1.8 TDCi	WS	1.8	92	4	03.06-	QYWA	10,0	Y-524J	4520	27
S-MAX 2.0 TDCi	WS	2.0	85	4	11.07-	KLWA	11,0	Y1005J	7957	56
S-MAX 2.0 TDCi	WS	2.0	85	4	11.07-	TYWA	5,0	Y8001AS	8904	58
S-MAX 2.0 TDCi	WS	2.0	96	4	03.06-	AZWA	11,0	Y1005J	7957	56
S-MAX 2.0 TDCi	WS	2.0	100	4	05.06-	AZWC, UKWA	11,0	Y1005J	7957	56
S-MAX 2.0 TDCi	WS	2.0	103	4	03.06-	QXWA, QXWB, QXWC	11,0	Y1005J	7957	56
S-MAX 2.0 TDCi	WS	2.0	103	4	03.06-	QXWB ohne DPF	11,5	Y-548J	94832	75
S-MAX 2.0 TDCi	WS	2.0	103	4	03.06-	UFWA	5,0	Y8001AS	8904	58
S-MAX 2.0 TDCi	WS	2.0	120	4	03.10-	TXWA	11,0	Y1005J	7957	56
S-MAX 2.2 TDCi	WS	2.2	129	4	03.08-	Q4WA	11,0	YE08	4966	
S-MAX 2.2 TDCi	WS	2.2	147	4	07.10-	KNWA	11,0	YE08	4966	

TOURNEO CONNECT

Tourneo Connect		1.8	55	4	06.02-	BHPA Endura-DI	10,0	Y-524J	4520	27
Tourneo Connect		1.8	66	4	06.02-	HCPA Duratorq-TDCi	10,0	Y-524J	4520	27
Tourneo Connect		1.8	66	4	06.02-	HCPB Duratorq-TDCi	10,0	Y-524J	4520	27
Tourneo Connect		1.8	81	4	06.02-	RWPA Duratorq-TDCi	10,0	Y-524J	4520	27

TOURNEO CONNECT II

Tourneo Connect II 1.5 EcoBlue	GAD	1.5	55	4	05.18-	BEGA	5,0	Y8012AS	93065	
Tourneo Connect II 1.5 EcoBlue	GAD	1.5	74	4	05.18-	Z2GA	5,0	Y8012AS	93065	
Tourneo Connect II 1.5 EcoBlue	GAD	1.5	88	4	05.18-	ZTGA	5,0	Y8012AS	93065	
Tourneo Connect II 1.6 TDCi	GAD	1.6	55	4	09.13-	UBGA	5,0	Y8001AS	8904	58
Tourneo Connect II 1.6 TDCi	GAD	1.6	70	4	09.13-	TZGA, TZGB	5,0	Y8001AS	8904	58
Tourneo Connect II 1.6 TDCi	GAD	1.6	85	4	09.13-	T1GA	5,0	Y8001AS	8904	58

TOURNEO CUSTOM

Tourneo Custom 2.2 TDCi	F3	2.2	74	4	09.12-	DRF4, DRFF, DRFG	4,4	Y1045AS	97520	89
Tourneo Custom 2.2 TDCi	F3	2.2	92	4	09.12-	CYF4, CYFF	4,4	Y1045AS	97520	89
Tourneo Custom 2.2 TDCi	F3	2.2	114	4	09.12-	CVFF	4,4	Y1045AS	97520	89

TRANSIT 2000

Transit 2000 (Front Wheel Drive)		2.0	55	4	08.00-05.06	D3FA	11,5	Y-548J	94832	75
Transit 2000 (Front Wheel Drive)		2.0	63	4	08.00-05.06	F3FA	11,5	Y-548J	94832	75
Transit 2000 (Front Wheel Drive)		2.0	74	4	08.00-05.06	ABFA	11,5	Y-548J	94832	75
Transit 2000 (Front Wheel Drive)		2.0	92	4	08.00-05.06	F1FA	11,5	Y-548J	94832	75
Transit 2000 (Rear Wheel Drive)		2.4	55	4	01.00-05.06	F4FA	11,5	Y-548J	94832	75
Transit 2000 (Rear Wheel Drive)		2.4	66	4	01.00-05.06	D2FA	11,5	Y-548J	94832	75
Transit 2000 (Rear Wheel Drive)		2.4	66	4	01.00-05.06	D2FB	11,5	Y-548J	94832	75
Transit 2000 (Rear Wheel Drive)		2.4	85	4	01.00-05.06	FXFA	11,5	Y-548J	94832	75
Transit 2000 (Rear Wheel Drive)		2.4	88	4	01.00-05.06	D4FA	11,5	Y-548J	94832	75
Transit 2000 (Rear Wheel Drive)		2.4	92	4	01.00-05.06	DOFA	11,5	Y-548J	94832	75
Transit 2000 (Rear Wheel Drive)		2.4	101	4	01.00-05.06	H9FA	11,5	Y-548J	94832	75

TRANSIT 2006

Transit 2006 (Front Wheel Drive)		2.2	63	4	04.06-	P8FA	11,5	Y-548J	94832	75
Transit 250 2.2 TDCi	FA	2.2	74	4	10.11-08.14	DRFA, DRFB, DRFC, DRFD, DRFE	4,4	Y1045AS	97520	89
Transit 260 2.2 TDCi	FA	2.2	74	4	10.11-08.14	DRFA, DRFB, DRFC, DRFD, DRFE	4,4	Y1045AS	97520	89





e kW C
Y
I



Stock-No
D-POWER

FORD

TRANSIT 2006

Transit 280 2.2 TDCi	FA, FB	2.2	74	4	10.11-08.14	DRFA, DRFB, DRFC, DRFD, DRFE	4,4	Y1045AS	97520	89
Transit 300 2.2 TDCi	FA, FB, FN, FM	2.2	74	4	10.11-08.14	DRFA, DRFB, DRFC, DRFD, DRFE, DRRA, DRRB, DRRC	4,4	Y1045AS	97520	89
Transit 330 2.2 TDCi	FA, FB, FN, FM	2.2	74	4	10.11-08.14	DRRA, DRRB, DRRC, DRFA, DRFB, DRFC, DRFD, DRFE	4,4	Y1045AS	97520	89
Transit 350 2.2 TDCi	FA, FB, FN, FM	2.2	74	4	10.11-08.14	DRRA, DRRB, DRRC, DRFA, DRFB, DRFC, DRFD, DRFE	4,4	Y1045AS	97520	89
Transit 2006 (Front Wheel Drive)		2.2	81	4	04.06-	QVFA	11,5	Y-548J	94832	75
Transit 260 2.2 TDCi	FA	2.2	92	4	10.11-08.14	CYFA, CYFB, CYFC, CYFD	4,4	Y1045AS	97520	89
Transit 280 2.2 TDCi	FA, FB	2.2	92	4	10.11-08.14	CYFA, CYFB, CYFC, CYFD	4,4	Y1045AS	97520	89
Transit 300 2.2 TDCi	FA, FB, FN, FM	2.2	92	4	10.11-08.14	CYFA, CYFB, CYFC, CYFD, CYRA	4,4	Y1045AS	97520	89
Transit 330 2.2 TDCi	FA, FB, FN, FM	2.2	92	4	10.11-08.14	CYFA, CYFB, CYFC, CYFD, CYRA, CYRB, CYRC	4,4	Y1045AS	97520	89
Transit 350 2.2 TDCi	FA, FB, FN, FM	2.2	92	4	10.11-08.14	CYFA, CYFB, CYFC, CYFD, CYRA, CYRB, CYRC	4,4	Y1045AS	97520	89
Transit 460 2.2 TDCi	FA, FM, FN	2.2	92	4	10.11-08.14	CYRA	4,4	Y1045AS	97520	89
Transit 2006 (Front Wheel Drive)		2.2	96	4	04.06-	QWFA	11,5	Y-548J	94832	75
Transit 350 2.2 TDCi	FB	2.2	100	4	09.11-08.14	USRA, URSB	4,4	Y1045AS	97520	89
Transit 460 2.2 TDCi	FA	2.2	100	4	10.11-08.14	USRA, URSB	4,4	Y1045AS	97520	89
Transit 300 2.2 TDCi	FM, FN	2.2	103	4	10.07-08.14	UHFA, UHFB, UHFC	4,4	Y1045AS	97520	89
Transit 350 2.2 TDCi	FM	2.2	103	4	10.11-08.14	UHFA, UHFB, UHFC	4,4	Y1045AS	97520	89
Transit 330 2.2 TDCi	FA, FM, FN	2.2	114	4	10.11-08.14	CVRA, CVRB, CVRC	4,4	Y1045AS	97520	89
Transit 350 2.2 TDCi	FA, FM, FN	2.2	114	4	10.11-08.14	CVRA, CVRB, CVRC	4,4	Y1045AS	97520	89
Transit 460 2.2 TDCi	FA, FM, FN	2.2	114	4	10.11-08.14	CVRA, CVRB, CVRC	4,4	Y1045AS	97520	89
Transit 370 2.4 TDCi	FB	2.4	74	4	04.06-08.14	PHFA, PHFC	4,4	Y1045AS	97520	89
Transit 430 2.4 TDCi	FA, FB	2.4	74	4	04.06-08.14	PHFA, PHFC	4,4	Y1045AS	97520	89
Transit 2006 (Rear Wheel Drive)		2.4	74	4	04.06-	PHFA	11,5	Y-548J	94832	75
Transit 2006 (Rear Wheel Drive)		2.4	85	4	04.06-	JXFA	11,5	Y-548J	94832	75
Transit 2006 (Rear Wheel Drive)		2.4	103	4	04.06-	H9FB	11,5	Y-548J	94832	75

TRANSIT 2014

Transit 290 2.2 TDCi	GFCD	2.2	74	4	08.13-	DRF5, DRFF, DRFG	4,4	Y1045AS	97520	89
Transit 310 2.2 TDCi	GFAD, GFCD, GFED	2.2	74	4	08.13-	DRF5, DRFF, DRFG, DRR5	4,4	Y1045AS	97520	89
Transit 330 2.2 TDCi	GFAD, GFED	2.2	74	4	08.13-	DRR5, DRF5, DRFF, DRFG	4,4	Y1045AS	97520	89
Transit 350 2.2 TDCi	GFAD, GFBD, GFCD, GFED	2.2	74	4	08.13-	DRR5, DRF5, DRFF, DRFG	4,4	Y1045AS	97520	89
Transit 290 2.2 TDCi	GFCD	2.2	92	4	08.13-	CYF5, CYFF, CYFG	4,4	Y1045AS	97520	89
Transit 310 2.2 TDCi/TDCi ECONetic	GFAD, GFCD, GFED	2.2	92	4	08.13-	CYF5, CYFF, CYFG, CYR5, USR6	4,4	Y1045AS	97520	89
Transit 330 2.2 TDCi/TDCi ECONetic	GFAD, GFCD, GFED	2.2	92	4	08.13-	CYR5, USR6, CYF5, CYFF, CYFG	4,4	Y1045AS	97520	89
Transit 350 2.2 TDCi	GFAD, GFBD, GFCD, GFED	2.2	92	4	08.13-	CYR5, USR6, CYF5, CYFF, CYFG, CY24	4,4	Y1045AS	97520	89
Transit 370 2.2 TDCi	GFBD	2.2	92	4	08.13-	CYR5, USR6	4,4	Y1045AS	97520	89
Transit 410 2.2 TDCi	GFBD	2.2	92	4	08.13-	CYR5, USR6	4,4	Y1045AS	97520	89
Transit 430 2.2 TDCi	GFDD, GFFD	2.2	92	4	08.13-	CYR5, USR6	4,4	Y1045AS	97520	89
Transit 460 2.2 TDCi	GFBD	2.2	92	4	08.13-	CYR5, USR6	4,4	Y1045AS	97520	89
Transit 470 2.2 TDCi	GFFD, GFDD	2.2	92	4	08.13-	CYR5, USR6	4,4	Y1045AS	97520	89
Transit 430 2.2 TDCi	GFFD	2.2	99	4	08.13-	UHR5	4,4	Y1045AS	97520	89
Transit 460 2.2 TDCi	GFBD	2.2	99	4	08.13-	UHR5	4,4	Y1045AS	97520	89





e kW C y i



Stock-No
D-POWER™

FORD

TRANSIT 2014

Transit 290 2.2 TDCi	GFCD	2.2	114	4	08.13-	CVF5, CVFF	4,4	Y1045AS	97520	89
Transit 310 2.2 TDCi	GFCD, GFED	2.2	114	4	08.13-	CVF5, CVFF, CVR5 UYR6	4,4	Y1045AS	97520	89
Transit 330 2.2 TDCi	GFAD, GFCD, GFED	2.2	114	4	08.13-	CVR5, UYR6, CVF5 CVFF	4,4	Y1045AS	97520	89
Transit 350 2.2 TDCi	GFBD, GFED, GFCD	2.2	114	4	08.13-	CVR5, UYR6, CVF5, CVFF	4,4	Y1045AS	97520	89
Transit 370 2.2 TDCi	GFBD	2.2	114	4	08.13-	CVR5, UYR6	4,4	Y1045AS	97520	89
Transit 410 2.2 TDCi	GFBD	2.2	114	4	08.13-	CVR5, UYR6	4,4	Y1045AS	97520	89
Transit 430 2.2 TDCi	GFFD, GFDD	2.2	114	4	08.13-	CVR5, UYR6	4,4	Y1045AS	97520	89
Transit 460 2.2 TDCi	GFBD	2.2	114	4	08.13-	CVR5, UYR6	4,4	Y1045AS	97520	89
Transit 470 2.2 TDCi	GFFD, GFDD	2.2	114	4	08.13-	CVR5, UYR6	4,4	Y1045AS	97520	89

TRANSIT CONNECT I

Transit Connect I	P65, P70, P80	1.8	55	4	06.02-	BHPA Endura-DI	10,0	Y-524J	4520	27
Transit Connect I	P65, P70, P80	1.8	66	4	06.02-	HCPA Duratorq-TDCi	10,0	Y-524J	4520	27
Transit Connect I	P65, P70, P80	1.8	66	4	06.02-	HCPB Duratorq-TDCi	10,0	Y-524J	4520	27
Transit Connect I	P65, P70, P80	1.8	81	4	06.02-	RWPA Duratorq-TDCi	10,0	Y-524J	4520	27

TRANSIT CONNECT II

Transit Connect II 1.5 EcoBlue	GCD	1.5	55	4	05.18-	BEGA	5,0	Y8012AS	93065	
Transit Connect II 1.5 EcoBlue	GCD	1.5	74	4	05.18-	Z2GA	5,0	Y8012AS	93065	
Transit Connect II 1.5 EcoBlue	GCD	1.5	88	4	05.18-	ZTGA	5,0	Y8012AS	93065	
Transit Connect II 1.6 TDCi	GCD	1.6	55	4	09.13-	UBGA	5,0	Y8001AS	8904	58
Transit Connect II 1.6 TDCi	GCD	1.6	70	4	09.13-	TZGA, TZGB	5,0	Y8001AS	8904	58
Transit Connect II 1.6 TDCi	GCD	1.6	85	4	09.13-	T1GA	5,0	Y8001AS	8904	58

TRANSIT CUSTOM

Transit Custom 250 2.2 TDCi	FY	2.2	74	4	09.12-	DRFF, DRFG	4,4	Y1045AS	97520	89
Transit Custom 270 2.2 TDCi/TDCi EConetic	FY, FZ	2.2	74	4	09.12-	DRF4, DRFF, DRFG	4,4	Y1045AS	97520	89
Transit Custom 290 2.2 TDCi/TDCi EConetic	FY, FZ	2.2	74	4	09.12-	DRF4, DRFF, DRFG	4,4	Y1045AS	97520	89
Transit Custom 300 2.2 TDCi	F3	2.2	74	4	09.12-	DRF4, DRFF, DRFG	4,4	Y1045AS	97520	89
Transit Custom 310 2.2 TDCi/TDCi EConetic	FY, FZ, F3	2.2	74	4	09.12-	DRF4, DRFF, DRFG	4,4	Y1045AS	97520	89
Transit Custom 270 2.2 TDCi	FY, FZ	2.2	92	4	09.12-	CYF4, CYFF	4,4	Y1045AS	97520	89
Transit Custom 290 2.2 TDCi	FY, FZ	2.2	92	4	09.12-	CYF4, CYFF	4,4	Y1045AS	97520	89
Transit Custom 300 2.2 TDCi	F3	2.2	92	4	09.12-	CYF4, CYFF	4,4	Y1045AS	97520	89
Transit Custom 310 2.2 TDCi	FY, FZ, F3	2.2	92	4	09.12-	CYF4, CYFF	4,4	Y1045AS	97520	89
Transit Custom 330 2.2 TDCi	FY, FZ, F3	2.2	92	4	09.12-	CYF4, CYFF	4,4	Y1045AS	97520	89
Transit Custom 270 2.2 TDCi	FY, FZ	2.2	114	4	09.12-	CVFF	4,4	Y1045AS	97520	89
Transit Custom 290 2.2 TDCi	FY, FZ	2.2	114	4	09.12-	CVFF	4,4	Y1045AS	97520	89
Transit Custom 300 2.2 TDCi	F3	2.2	114	4	09.12-	CVFF	4,4	Y1045AS	97520	89
Transit Custom 310 2.2 TDCi	FY, FZ, F3	2.2	114	4	09.12-	CVFF	4,4	Y1045AS	97520	89
Transit Custom 330 2.2 TDCi	FY, FZ, F3	2.2	114	4	09.12-	CVFF	4,4	Y1045AS	97520	89

FORD (USA)

RANGER

Ranger 2.2 TDCi	2G, 2N, 2P	2.2	92	4	04.11-	GBVAJQW	4,4	Y1045AS	97520	89
Ranger 2.2 TDCi	2G, 2N, 2P	2.2	96	4	05.15-	T22DD0P	4,4	Y1045AS	97520	89
Ranger 2.2 TDCi	2G, 2N, 2P	2.2	110	4	04.11-	GBVAJQJ	4,4	Y1045AS	97520	89





el kW C
y
i



Stock-No
D-POWER

FORD (USA)

RANGER

Ranger 2.2 TDCi	2G, 2P	2.2	118	4	05.15-	T22DD0P	4,4	Y1045AS	97520	89
Ranger 3.2 TDCi	2G, 2N, 2P	3.2	147	5	04.11-	SAFA	4,4	Y1045AS	97520	89

FSO

POLONEZ CARO

Polonez Caro D		1.9	51	4	10.92-	XUD Kat.	11,0	Y-924J	7906	1
----------------	--	-----	----	---	--------	----------	------	--------	------	---

HONDA

ACCORD

Accord TDi		2.0	77	4	05.95-08.99	Rover (L-Serie)	11,0	Y-730U	6704	17
Accord TDi CF1		2.0	77	4	09.99-	20TN2	11,0	Y-730U	6704	17
Accord 2.2 i-CTDi	CN1, CN2	2.2	103	4	11.03-05.08	N22A1	11,0	CZ274	95233	
Accord 2.2 i-DTEC	CU3, CW3	2.2	110	4	06.08-06.15	N22B1	11,0	CZ274	95233	
Accord 2.2 i-DTEC	CU3, CW3	2.2	132	4	01.10-06.15	N22B2	11,0	CZ274	95233	

CIVIC

Civic 1.6 i-DTEC	FK, FK9, FC8	1.6	88	4	02.13-	N16A1	11,0	CZ274	95233	
Civic 1.7 CTDi EP4		1.7	74	4	.02-	4EE2	11,0	Y-541J	1983	42
Civic 2.2 i-CTDi/i-CTDi GT Type S/i-CTDi Type S	FK3, FN3	2.2	103	4	09.05-12.11	N22A2	11,0	CZ274	95233	
Civic 2.2 i-DTEC	FK	2.2	110	4	02.12-	N22B4	11,0	CZ274	95233	

CONCERTO

Concerto TD		1.8	64	4	10.94-12.95	XUD 7 TE	11,0	Y-924J	7906	1
-------------	--	-----	----	---	-------------	----------	------	--------	------	---

CR-V 2

CR-V 2 2.2 i-CTDi	RD9	2.2	103	4	01.05-09.06	N22A2	11,0	CZ274	95233	
-------------------	-----	-----	-----	---	-------------	-------	------	-------	-------	--

CR-V 3

CR-V 3 2.2 i-CTDi	RE6	2.2	103	4	10.06-09.09	N22A2	11,0	CZ274	95233	
CR-V 3 2.2 i-DTEC	RE6	2.2	110	4	10.09-06.12	N22B3	11,0	CZ274	95233	

CR-V 4

CR-V 4 1.6 i-DTEC	RE6	1.6	88	4	10.13-	N16A2	11,0	CZ274	95233	
CR-V 4 1.6 i-DTEC	RE6	1.6	118	4	02.15-	N16A4	11,0	CZ274	95233	
CR-V 4 2.2 i-DTEC	RE6	2.2	110	4	10.12-	N22B4	11,0	CZ274	95233	

FR-V

FR-V 2.2 i-CTDi	BE5	2.2	103	4	06.05-12.09	N22A1	11,0	CZ274	95233	
-----------------	-----	-----	-----	---	-------------	-------	------	-------	-------	--

HR-V

HR-V 1.6 i-Dtec	RU8	1.6	88	4	08.15-	N16A3	11,0	CZ274	95233	
-----------------	-----	-----	----	---	--------	-------	------	-------	-------	--

HYUNDAI

ACCENT

Accent TDI		1.5	55	3	04.02-		11,0	Y-749J	5013	
Accent 12V CRDi		1.5	60	3	04.02-	D3EA	11,0	Y-749J	5013	

ACCENT III (MC)

Accent III 1.5 CRDi	MC	1.5	81	4	11.05-	D4FA	11,0	Y-527J	96187	67
---------------------	----	-----	----	---	--------	------	------	--------	-------	----

ELANTRA

Elantra 1.6 CRDi	XD	1.6	85	4	02.06-	D4FB	11,0	Y-527J	96187	67
Elantra CRDi		2.0	83	4	.01-	D4EA	11,0	Y-749J	5013	

GALLOPER

Galopper		2.5	57	4	-01.94	4D55	12,0	Y-115T1	2189	
Galopper TC, TCI		2.5	65	4	11.95-	4D56	11,0	CZ257	97284	83





l kW C
y i



Stock-No
D-POWER™

HYUNDAI

GALLOPER

Galopper TD	2.5	65	4	11.97-06.03	D4BA	11,0	CZ257	97284	83
Galopper TDCi	2.5	73	4	11.97-06.03	D4BH	11,0	CZ257	97284	83
Galopper TDCi	2.5	77	4	11.97-06.03	D4BH	11,0	CZ257	97284	83

GETZ

Getz 1.5 CRDi	TB	1.5	60	3	02.03-07.05	D3EA	11,0	Y-749J	5013	
Getz 1.5 CRDi	TB	1.5	60	3	08.05-10.06	D3EA	11,0	Y-527J	96187	67
Getz 1.5 CRDi	TB	1.5	65	4	11.06-	D4FA	11,0	Y-527J	96187	67
Getz 1.5 CRDi	TB	1.5	81	4	11.06-	D4FA	11,0	Y-527J	96187	67

H 1

H1 TDiC	2.5	59	4	06.97-04.04	D4BF	11,0	CZ257	97284	83
H1 TDiC	2.5	59	4	02.98-04.04	D4BF	11,0	CZ257	97284	83
H1 TDCi	2.5	73	4	10.97-12.07	D4BH	11,0	CZ257	97284	83
H1 TDCi	2.5	74	4	05.04-12.07	D4BH	11,0	CZ257	97284	83
H1 TDiC	2.6	63	4	10.97-10.02	D4BB	11,0	CZ257	97284	83
H1 TDiC	2.6	79	4	10.97-08.00	D4BB	11,0	CZ257	97284	83

H 100

H100	2.5	55	4	07.93-12.94	D4BX	11,0	CZ257	97284	83
H100 AU Truck TDiC	2.5	59	4	05.96-12.97	D4BF	11,0	CZ257	97284	83
H100 AU Truck TDCi	2.5	73	4	08.03-10.06	D4BH	11,0	CZ257	97284	83
H100 Truck TDCi	2.5	73	4	02.04-10.06	D4BH	11,0	CZ257	97284	83
H100 Truck TD	2.5	74	4	11.06-	4D56T	11,0	CZ257	97284	83
H100 AU Truck TD	2.6	63	4	04.96-12.98	D4BB	11,0	CZ257	97284	83
H100 Truck TD	2.6	66	4	11.06-	T2	11,0	CZ257	97284	83

H 200

H200 TD	2.5	57	4	10.97-07.01	D4BF	11,0	CZ257	97284	83
H200 TDiC	2.5	59	4	06.97-12.02	D4BF	11,0	CZ257	97284	83
H200 TDCi	2.5	73	4	10.97-10.05	D4BH	11,0	CZ257	97284	83
H200 TDCi	2.5	74	4	10.01-09.05	D4BH	11,0	CZ257	97284	83

I10

i10 1.1 CRDi	PA	1.1	55	3	03.08-	D3FA	11,0	Y-527J	96187	67
--------------	----	-----	----	---	--------	------	------	--------	-------	----

I20

i20 1.4 CRDi	PB	1.4	55	4	12.08-	D4FC	11,0	Y-527J	96187	67
i20 1.4 CRDi	PB	1.4	66	4	05.09-	D4FC	11,0	Y-527J	96187	67
i20 1.6 CRDi		1.6	85	4	12.08-	D4FB	11,0	Y-527J	96187	67

I30 1

i30 I 1.6 CRDi	FD	1.6	66	4	10.07-	D4FB	11,0	Y-527J	96187	67
i30 I 1.6 CRDi	FD	1.6	85	4	10.07-	D4FB	11,0	Y-527J	96187	67
i30 I 1.6 CRDi	FD	1.6	94	4	02.08-	D4FB	11,0	Y-527J	96187	67
i30 I 2.0 CRDi	FD	2.0	103	4	07.07-	D4EA	11,0	Y-749J	5013	

I30 2

i30 II 1.4 CRDi	GD	1.4	66	4	11.11-	D4FC	11,0	Y-527J	96187	67
i30 II 1.6 CRDi	GD	1.6	81	4	11.11-	D4FB	11,0	Y-527J	96187	67
i30 II 1.6 CRDi	GD	1.6	94	4	11.11-	D4FB	11,0	Y-527J	96187	67

I30 CW 1

i30 CW I 1.6 CRDi		1.6	94	4	02.08-	D4FB	11,0	Y-527J	96187	67
-------------------	--	-----	----	---	--------	------	------	--------	-------	----





l kW C
y I



Stock-No
D-POWER

HYUNDAI

I40

i40 1.7 CRDi	VF	1.7	85	4	06.11-	D4FD	11,0	CZ203	95232	68
i40 1.7 CRDi	VF	1.7	100	4	06.11-	D4FD	11,0	CZ203	95232	68

IX20

ix20 1.4 CRDi	JC	1.4	57	4	11.10-	D4FC	11,0	Y-527J	96187	67
ix20 1.4 CRDi	JC	1.4	66	4	11.10-	D4FC	11,0	Y-527J	96187	67
ix20 1.6 CRDi	JC	1.6	85	4	11.10-	D4FB	11,0	Y-527J	96187	67

IX35 (LM)

ix35 1.7 CRDi	LM	1.7	85	4	09.10-	D4FD	11,0	CZ203	95232	68
ix35 2.0 CRDi (Euro 5)	LM	2.0	100	4	08.09-	D4HA	7,0	CZ105	90007	
ix35 2.0 CRDi (Euro 3 / euro 4)	LM	2.0	100	4	08.09-	D4HA	5,0	Y1003AS	92283	
ix35 2.0 CRDi (Euro 5)	LM	2.0	135	4	08.09-	D4HA	7,0	CZ105	90007	
ix35 2.0 CRDi (Euro 3 / euro 4)	LM	2.0	135	4	08.09-	D4HA	5,0	Y1003AS	92283	

LANTRA

Lantra D		1.9	50	4	.98-	XUD9A	11,0	Y-924J	7906	1
----------	--	-----	----	---	------	-------	------	--------	------	---

MATRIX

Matrix 1.5 CRDi	FC	1.5	60	3	10.01-02.05	D3EA	11,0	Y-749J	5013	
Matrix 1.5 CRDi	FC	1.5	75	4	12.04-	D4FA	11,0	Y-527J	96187	67
Matrix 1.5 CRDi VGT	FC	1.5	81	4	08.05-	D4FA	11,0	Y-527J	96187	67

SANTA FE I (SM)

Santa Fe I CRDi	SM	2.0	83	4	04.01- .05	D4EA	11,0	Y-749J	5013	
Santa Fe I CRDi 4x4	SM	2.0	92	4	08.03-	D4EA	11,0	Y-749J	5013	
Santa Fe I CRDi	SM	2.2	102	4	03.06-	D4EB	11,0	Y-749J	5013	
Santa Fe I CRDi	SM	2.2	110	4	10.05-	D4EB	11,0	Y-749J	5013	
Santa Fe I CRDi	SM	2.2	114	4	03.06-	D4EB	11,0	Y-749J	5013	

SANTA FE II (CM)

Santa Fe II 2.0 CRDi (Euro 5)	CM	2.0	110	4	12.10-08.12	D4HA	7,0	CZ105	90007	
Santa Fe II 2.0 CRDi (Euro 4)	CM	2.0	110	4	12.10-12.12	D4HA	5,0	Y1003AS	92283	

SANTA FE III (DM)

Santa Fe III 2.2 CRDi Automatic (Euro 5)	DM	2.2	145	4	09.12-	D4HB	5,0	Y1003AS	92283	
--	----	-----	-----	---	--------	------	-----	---------	-------	--

SATELLITE

Satellite TDCi		2.5	59	4	10.97-11.02	D4BF	11,0	CZ257	97284	83
Satellite TDCi		2.5	59	4	10.97-11.02	D4BH	11,0	CZ257	97284	83
Satellite TDCi		2.5	73	4	03.01-10.05	D4BH	11,0	CZ257	97284	83
Satellite TDCi		2.5	74	4	11.01-10.05	D4BH	11,0	CZ257	97284	83

SONATA

Sonata 2.0 CRDi		2.0	103	4	02.06-	D4EA	11,0	Y-749J	5013	
-----------------	--	-----	-----	---	--------	------	------	--------	------	--

STAREX

Starex TDiC		2.5	59	4	06.97-04.04	D4BF	11,0	CZ257	97284	83
Starex 2.5TD		2.5	59	4	06.97-		11,0	Y-722JS	9974	
Starex TDCi		2.5	74	4	09.00-08.07	D4BH	11,0	CZ257	97284	83
Starex TDiC		2.6	63	4	10.97-04.04	D4BB	11,0	CZ257	97284	83

TERRACAN

Terracan TDiC		2.5	74	4	06.01-10.03	D4BHG	11,0	CZ257	97284	83
Terracan Van TDiC		2.5	74	4	06.01-10.03	D4BHG	11,0	CZ257	97284	83
Terracan CRDi		2.9	110	4	10.01-		11,0	CZ257	97284	83





e kW C y i

Stock-No
D-POWER™**HYUNDAI****TERRACAN**

Terracan	2.9	120	4	11.03-	J3	11,0	CZ257	97284	83
----------	-----	-----	---	--------	----	------	-------	-------	----

TRAJET

Trajet CRDI	2.0	83	4	04.01- .04	4DEA	11,0	Y-749J	5013	
-------------	-----	----	---	------------	------	------	--------	------	--

TUCSON

Tucson D	2.0	83	4	09.04-	D4EA	11,0	Y-749J	5013	
----------	-----	----	---	--------	------	------	--------	------	--

Tucson D	2.0	103	4	02.06-	D4EA	11,0	Y-749J	5013	
----------	-----	-----	---	--------	------	------	--------	------	--

INFINITI**EX SERIES**

EX Series 3.0	J50	3.0	175	6	04.10-	V9X	7,0	CZ167	90646	91
---------------	-----	-----	-----	---	--------	-----	-----	-------	-------	----

FX SERIES

FX Series 3.0	S51	3.0	175	6	04.10-07.13	V9X	7,0	CZ167	90646	91
---------------	-----	-----	-----	---	-------------	-----	-----	-------	-------	----

M SERIES

M Series 3.0	Y51	3.0	175	6	03.10-	V9X	7,0	CZ167	90646	91
--------------	-----	-----	-----	---	--------	-----	-----	-------	-------	----

Q SERIES

Q 70 MK I 3.0	Y51	3.0	175	6	09.13-	V9X	7,0	CZ167	90646	91
---------------	-----	-----	-----	---	--------	-----	-----	-------	-------	----

QX SERIES

QX 50 3.0	J50	3.0	175	6	08.13-	V9X	7,0	CZ167	90646	91
-----------	-----	-----	-----	---	--------	-----	-----	-------	-------	----

QX 70 3.0	S51	3.0	175	6	08.13-	V9X	7,0	CZ167	90646	91
-----------	-----	-----	-----	---	--------	-----	-----	-------	-------	----

INNOCENTI**ELBA D**

Elba D	1.7	42	4	09.92-	146B2000	11,0	Y-924J	7906	1
--------	-----	----	---	--------	----------	------	--------	------	---

ISUZU**TROOPER**

Trooper TD	3.1	83	4	06.92-	4JG2T	11,0	Y-711J	4467	28
------------	-----	----	---	--------	-------	------	--------	------	----

IVECO**DAILY**

Daily TDi	2.8	90	6	09.97-		11,0	Y-502R	3852	
-----------	-----	----	---	--------	--	------	--------	------	--

JAGUAR**S-TYPE**

S-Type 2.7 D	2.7	152	6	06.04-		11,0	YE12	7794	
--------------	-----	-----	---	--------	--	------	------	------	--

XF SERIE

XF 2.7 D	X250	2.7	152	6	03.08-	AJD	11,0	YE12	7794	
----------	------	-----	-----	---	--------	-----	------	------	------	--

XJ SERIE

XJ6 2.7 TDVi	2.7	152	6	10.05-		11,0	YE12	7794	
--------------	-----	-----	---	--------	--	------	------	------	--

X-TYPE

X-Type 2.0 D	2.0	96	4	07.03-10.05	R4-X404	11,5	Y-548J	94832	75
--------------	-----	----	---	-------------	---------	------	--------	-------	----

X-Type 2.2 D	2.2	114	4	10.05-	LJ46G	11,0	YE08	4966	
--------------	-----	-----	---	--------	-------	------	------	------	--

JEEP**CHEROKEE**

Cherokee TD	2.1	59	6	01.88-		11,0	Y-924J	7906	1
-------------	-----	----	---	--------	--	------	--------	------	---

Cherokee TD	2.1	65	4	01.87-01.91	Renault J8S 814, J8S 890	11,0	Y-924J	7906	1
-------------	-----	----	---	-------------	--------------------------	------	--------	------	---

Cherokee TD	2.1	65	4	02.91-08.94	J8S 890	11,0	Y-913J	5317	15
-------------	-----	----	---	-------------	---------	------	--------	------	----

Cherokee TD	2.5	85	4	05.95-07.99	VM HR 425	11,0	Y-741U	6943	20
-------------	-----	----	---	-------------	-----------	------	--------	------	----





el kW C
Y
I



Stock-No
D-POWER

JEEP

CHEROKEE

Cherokee 2.8 CRDi	KK	2.8	130	4	05.08-03.13	ENS	4,4	Y8011AS	90403	
Cherokee 2.8 CRDi	KK	2.8	147	4	01.10-03.13	ENS	4,4	Y8011AS	90403	

CHEROKEE (KJ)

Cherokee 2.5 CRD	KJ	2.5	105	4	09.01-10.02	ENJ	11,0	Y1031J	95970	71
Cherokee 2.8 CRD	KJ	2.8	110	4	09.02-01.08	ENR	11,0	Y1031J	95970	71
Cherokee 2.8 CRD	KJ	2.8	120	4	11.04-12.04	ENR	11,0	Y1031J	95970	71

COMMANDER

Commander 3.0 CRD		3.0	160	6	04.06-12.10	EXL	4,4	Y8002AS	6287	51
-------------------	--	-----	-----	---	-------------	-----	-----	---------	------	----

COMPASS

Compass CRD		2.0	103	4	.06-		7,0	CZ304	9864	55
-------------	--	-----	-----	---	------	--	-----	-------	------	----

GRAND CHEROKEE

Grand Cherokee TD		2.5	88	4	01.93-	VM HR 425 CLIRE	11,0	Y-924J	7906	1
Grand Cherokee TD		2.5	88	4	01.93-	VM HR-492	11,0	Y-924J	7906	1
Grand Cherokee TD		2.5	110	4	04.99-	ENC	11,0	Y-741U	6943	20
Grand Cherokee CRD		2.7	120	5	01.02-	CDI Mercedes	11,5	Y-745U	6346	11
Grand Cherokee 3.0 CRD	WH	3.0	155	6	05.06-12.10	EXL	4,4	Y8002AS	6287	51
Grand Cherokee 3.0 CRD	WH	3.0	160	6	06.05-12.10	EXL	4,4	Y8002AS	6287	51
Grand Cherokee TD / Limited		3.1	103	5	04.98-	EXA	11,0	Y-741U	6943	20

GRAND VOYAGER

Grand Voyager 2.5 Td Le		2.5	88	4	05.95-	VM HR425 CLIEE	11,0	Y-741U	6943	20
-------------------------	--	-----	----	---	--------	----------------	------	--------	------	----

LIBERTY

Liberty 2.8 CRDi	KK	2.8	130	4	11.07-12.10	ENS	4,4	Y8011AS	90403	
------------------	----	-----	-----	---	-------------	-----	-----	---------	-------	--

WRANGLER

Wrangler Laredo, Sahara, Texan TD		2.1	65	4	07.88-		11,0	Y-924J	7906	1
Wrangler		2.5		6	07.88-		11,0	Y-924J	7906	1
Wrangler, Laredo, Sahara		2.5		6	07.88-		11,0	Y-924J	7906	1
Wrangler, Texan D		2.5		6	07.88-		11,0	Y-924J	7906	1
Wrangler 2.8 CRDi	JK74	2.8	130	4	11.06-12.10	ENS	4,4	Y8011AS	90403	
Wrangler 2.8 CRDi	JK72	2.8	130	4	11.06-12.10	ENS	4,4	Y8011AS	90403	
Wrangler 2.8 CRDi	JK74	2.8	147	4	11.10-12.10	ENS	4,4	Y8011AS	90403	
Wrangler 2.8 CRDi	JK72	2.8	147	4	11.10-12.10	ENS	4,4	Y8011AS	90403	

KIA

BESTA

Besta 2.2		2.2	52	4	03.90-07.99	HW	11,0	Y-701J	1566	39
Besta 2.7		2.7	60	4	03.90-07.99	VN	11,0	Y-701J	1566	39

CARENS

Carens 2.0 CRDI EX		2.0	83	4	.02-	D4EA	11,0	Y-749J	5013	
--------------------	--	-----	----	---	------	------	------	--------	------	--

CARENS III

Carens III 1.6 CRDi		1.6	85	4	06.10-	D4FB	11,0	Y-527J	96187	67
Carens III 1.6 CRDi		1.6	94	4	07.10-	D4FB	11,0	Y-527J	96187	67
Carens III 2.0 CRDi		2.0	85	4	05.06-	D4EA	11,0	Y-749J	5013	
Carens III 2.0 CRDi		2.0	103	4	.06-	D4EA	11,0	Y-749J	5013	
Carens III 2.0 CRDi		2.0	136	4	05.06-	D4EA	11,0	Y-749J	5013	

CARENS IV

Carens IV 1.7 CRDi		1.7	85	4	03.13-	D4FD	11,0	CZ203	95232	68
--------------------	--	-----	----	---	--------	------	------	-------	-------	----





e kW C y i



Stock-No
D-POWER™

KIA

CARENS IV

Carens IV 1.7 CRDi		1.7	100	4	03.13-	D4FD		11,0	CZ203	95232	68
--------------------	--	-----	-----	---	--------	------	--	------	-------	-------	----

CARNIVAL III

Carnival III 2.2 CRDi	VQ	2.2	110	4	01.10-	D4HB		7,0	CZ105	90007	
Carnival III 2.2 CRDi	VQ	2.2	143	4	01.10-	D4HB		7,0	CZ105	90007	
Carnival III 2.9 CRDi	VQ	2.9	136	4	06.06-	J3		11,0	Y-535J	91416	

CEE'D (ED)

Cee'd 1.6 CRDi	ED	1.6	66	4	12.06-10.10	D4FB-L		11,0	CZ203	95232	68
Cee'd 1.6 CRDi	ED	1.6	66	4	11.10-	D4FB-L		11,0	Y-527J	96187	67
Cee'd 1.6 CRDi	ED	1.6	85	4	12.06-10.10	D4FB		11,0	Y-527J	96187	67
Cee'd 1.6 CRDi	ED	1.6	85	4	11.10-12.12	D4FB		11,0	CZ203	95232	68
Cee'd 1.6 CRDi	ED	1.6	94	4	06.10-10.10	D4FB		11,0	CZ203	95232	68
Cee'd 1.6 CRDi	ED	1.6	94	4	11.10-	D4FB		11,0	Y-527J	96187	67
Cee'd 2.0 CRDi	ED	2.0	103	4	07.07-12.12	D4EA		11,0	Y-749J	5013	

CERATO

Cerato 1.5 CRDi		1.5	75	4	08.04-08.06	D4FA		11,0	Y-527J	96187	67
Cerato 1.6 CRDi		1.6	85	4	06.05-06.08	D4FB		11,0	Y-527J	96187	67
Cerato 2.0 CRDi		2.0	83	4	04.04-	D4EA		11,0	Y-749J	5013	

K 2500

K2500 TDCi		2.5	93	4	05.02-10.03	D4BH		11,0	CZ257	97284	83
------------	--	-----	----	---	-------------	------	--	------	-------	-------	----

K 2900

K 2900 2.9 D		2.9	92	4	08.07-	J3		11,0	Y-535J	91416	
--------------	--	-----	----	---	--------	----	--	------	--------	-------	--

MAGENTIS

Magentis CRDi		2.0	103	4	04.06- .09	D4EA		11,0	Y-749J	5013	
---------------	--	-----	-----	---	------------	------	--	------	--------	------	--

OPTIMA

Optima 1.7 CRDi	TF	1.7	100	4	03.12-	D4FD		11,0	CZ203	95232	68
-----------------	----	-----	-----	---	--------	------	--	------	-------	-------	----

PICANTO

Picanto 1.1 CRDi	BA	1.1	55	3	11.05-	D3FA		11,0	Y-527J	96187	67
------------------	----	-----	----	---	--------	------	--	------	--------	-------	----

PREGIO

Pregio TDCi		2.5	69	4	08.01-07.06	D4BH		11,0	CZ257	97284	83
Pregio		2.7	60	4	06.96-	J2		11,0	Y-701J	1566	39
Pregio		3.0	66	4	06.97-	W3, NB9		11,0	Y-701J	1566	39

RETONA

Retona		2.0	61	4	04.00-			11,0	Y-721J	6919	
--------	--	-----	----	---	--------	--	--	------	--------	------	--

RIO II

Rio II 1.5 CRDi		1.5	81	4	06.05-	D4FA		11,0	Y-527J	96187	67
-----------------	--	-----	----	---	--------	------	--	------	--------	-------	----

RIO III

Rio III 1.1 CRDi	UB	1.1	55	3	06.11-	D3FA		11,0	Y-527J	96187	67
Rio III 1.4 CRDi	UB	1.4	66	4	06.11-	D4FC		11,0	Y-527J	96187	67

SEDONA II

Sedona MkII 2.2 CRDi	VQ	2.2	143	4	01.10-	D4HB		7,0	CZ105	90007	
----------------------	----	-----	-----	---	--------	------	--	-----	-------	-------	--

SORENTO (JC)

Sorento CRDi	JC	2.5	103	4	08.02-			11,0	Y-508J	3709	
--------------	----	-----	-----	---	--------	--	--	------	--------	------	--

SORENTO (XM)

Sorento 2.0 CRDi	XM	2.0	110	4	07.09-	D4HA		5,0	Y1003AS	92283	
Sorento 2.2 CRDi (For cold climate zones)	XM	2.2	145	4	11.09-	D4HB		7,0	CZ105	90007	





€ kW C
Y I



Stock-No
D-POWER

KIA

SORENTO (XM)

Sorento 2.2 CRDi (For hot climate zones)	XM	2.2	145	4	11.09-	D4HB	5,0	Y1003AS	92283	
--	----	-----	-----	---	--------	------	-----	---------	-------	--

SOUL

Soul 1.6 CRDi	AM	1.6	85	4	02.09-	D4FB	11,0	Y-527J	96187	67
Soul 1.6 CRDi	AM	1.6	94	4	02.09-	D4FB	11,0	Y-527J	96187	67

SPORTAGE

Sportage TD		2.0	61	4	07.96-08.99	Mazda engine	11,0	Y-701J	1566	39
Sportage		2.0	83	4	11.04-	D4EA	11,0	Y-749J	5013	
Sportage 2.0 CRDi		2.0	103	4	.06-	D4EA	11,0	Y-749J	5013	

SPORTAGE (SL)

Sportage 1.7 CRDi	SL	1.7	85	4	11.10-	D4FD	11,0	CZ203	95232	68
Sportage 2.0 CRDi	SL	2.0	110	4	07.10-	D4HA	7,0	CZ105	90007	
Sportage 2.0 CRDi 4x4 Automatic	SL	2.0	110	4	07.10-	D4HA	5,0	Y1003AS	92283	

VENGA

Venga 1.4 CRDi (Euro 5)		1.4	55	4	02.10-	D4FC	11,0	CZ203	95232	68
Venga 1.4 CRDi (Euro 3 / Euro 4)		1.4	55	4	02.10-	D4FC	11,0	Y-527J	96187	67
Venga 1.4 CRDi (Euro 5)		1.4	57	4	02.10-	D4FC	11,0	CZ203	95232	68
Venga 1.4 CRDi (Euro 4)		1.4	57	4	02.10-	D4FC	11,0	Y-527J	96187	67
Venga 1.4 CRDi (Euro 5)		1.4	66	4	02.10-	D4FC	11,0	CZ203	95232	68
Venga 1.4 CRDi (Euro 3 / Euro 4)		1.4	66	4	02.10-	D4FC	11,0	Y-527J	96187	67
Venga 1.6 CRDi (Euro 5)		1.6	85	4	02.10-	D4FB	11,0	CZ203	95232	68
Venga 1.6 CRDi (Euro 4)		1.6	85	4	02.10-	D4FB	11,0	Y-527J	96187	67
Venga 1.6 CRDi (Euro 5)		1.6	94	4	02.10-	D4FB	11,0	CZ203	95232	68
Venga 1.6 CRDi (Euro 4)		1.6	94	4	02.10-	D4FB	11,0	Y-527J	96187	67

LADA (AVTOVAZ)

ALEKO

Aleko D		1.8	44	4	01.87-	Ford RTE, RTS	11,5	Y-910J	3617	3
---------	--	-----	----	---	--------	---------------	------	--------	------	---

NIVA

Niva D		1.9	47	4	10.93-	Peugeot XUD 9L	11,0	Y-924J	7906	1
--------	--	-----	----	---	--------	----------------	------	--------	------	---

SAGONA

Sagona D		1.5	40	4	01.95-	TUD5	11,0	Y-503J	1009	10
----------	--	-----	----	---	--------	------	------	--------	------	----

SAMARA

Samara D		1.5	40	4	01.95-	TUD 5	11,0	Y-503J	1009	10
----------	--	-----	----	---	--------	-------	------	--------	------	----

LANCIA

DEDRA

Dedra TD		1.9	66	4	03.89-09.94	835 A 4.000	11,0	Y-924J	7906	1
Dedra TD ds		1.9	66	4	10.94-	160D1000	11,0	Y-924J	7906	1
Dedra Eco LE TD		1.9	68	4	06.93-	160D1000	11,0	Y-924J	7906	1

DELTA

Delta TD		1.9	59	4	06.86-06.91	831 D 1.000	11,0	Y-924J	7906	1
Delta HPE TD		1.9	66	4	10.94-	160D1000	11,0	Y-924J	7906	1
Delta TD ds		1.9	66	4	10.94-	160D1000	11,0	Y-924J	7906	1
Delta TD- ds LE		1.9	66	4	10.94-	160D1000	11,0	Y-924J	7906	1
Delta TD LS		1.9	66	4	10.94-	160D1000	11,0	Y-924J	7906	1
Delta HPE Td		1.9	66	4	10.96-		11,0	Y-928U	4389	29





e kW C y i

Stock-No
D-POWER™**LANCIA****DELTA 3 (844)**

Delta 3 1.6 D MJET	844	1.6	77	4	04.11-	844A3000	4,4	Y9003AS	94251	78
Delta 3 1.6 D MJET	844	1.6	85	4	09.08-	955A4000	4,4	Y9003AS	94251	78
Delta 3 1.6 D MJET	844	1.6	88	4	07.08-	198A2000	4,4	Y9003AS	94251	78
Delta 3 1.9 D MJET	844	1.9	140	4	09.08-	844A1000	4,4	Y9003AS	94251	78
Delta 3 2.0 D MJET	844	2.0	120	4	09.08-	844A2000	4,4	Y9003AS	94251	78
Delta 3 2.0 D MJET	844	2.0	121	4	07.08-	198A5000	4,4	Y9003AS	94251	78

KAPPA

KAPPA / SW / Coupe 2.4 JTD (Engine No→1713818)		2.4	100	5	06.98-10.99	838A8000	11,0	Y-747U	4694	26
KAPPA / SW / Coupe 2.4 JTD (Engine No 1713819→)		2.4	100	5	11.99- .04	838A8000	11,0	Y-534J	3413	36
KAPPA TD		2.4		5	10.94-12.98	838 A3.000	11,5	Y-910J	3617	3

LYBRA

Lybra 1.9 JTD (Engine No→1713818)		1.9	77	4	09.98-11.99	AR32302	11,0	Y-747U	4694	26
Lybra 1.9 JTD (Engine No 1713819→)		1.9	77	4	12.99-09.00	AR32302	11,0	Y-534J	3413	36
Lybra 1.9 JTD		1.9	81	4	09.00-05.01	AR 37101	11,0	Y-534J	3413	36
Lybra 1.9 JTD		1.9	85	4	06.01- .04	937A2000	11,0	Y-534J	3413	36
Lybra 2.4 JTD (Engine No→1713818)		2.4	100	5	09.99-11.99	AR32501	11,0	Y-747U	4694	26
Lybra 2.4 JTD (Engine No 1713819→)		2.4	100	5	11.99-12.00	AR32501	11,0	Y-534J	3413	36
Lybra 2.4 JTD		2.4	103	5	09.00-05.02	839 A6.000	11,0	Y-534J	3413	36
Lybra 2.4 JTD		2.4	110	5	05.02- .04	841C000	11,0	Y-534J	3413	36

MUSA

Musa 1.3 D MJET (Euro 4)		1.3	51	4	09.04-12.12	188A9000	11,0	Y8003J	97256	62
Musa 1.3 D MJET (Euro 5)		1.3	51	4	.11-12.12	188A9000	4,3	Y9001AS	97719	72
Musa 1.3 D MJET		1.3	66	4	02.05-	199A3000	4,3	Y9001AS	97719	72
Musa 1.3 D MJET (Euro 5)		1.3	66	4	.11-	199A3000	4,3	Y9001AS	97719	72
Musa 1.3 D MJET (Euro 5)		1.3	70	4	03.09-	199B1000	4,3	Y9001AS	97719	72
Musa 1.6 D MJET		1.6	85	4	07.08-12.12	350A3000	4,4	Y9003AS	94251	78
Musa 1.6 D MJET		1.6	88	4	06.08-	350A2000	4,4	Y9003AS	94251	78
Musa 1.9 D MJET		1.9	74	4	10.04-12.12	188B2000	11,0	Y-534J	3413	36

PHEDRA

Phedra JTD (Engine No→9666)		2.0	79	4	09.02-05.03	RHM (DW10ATED4)	11,0	Y-504J	1441	24
Phedra JTD		2.0	80	4	09.02-	DW10ATED4, RHT, RHW	11,0	Y-504J	1441	24
Phedra JTD (Engine No→9666)		2.0	80	4	09.02-05.03	RHM (DW10ATED4)	11,0	Y-504J	1441	24
Phedra 2.0 D Multijet		2.0	88	4	03.06-11.10	RHK (DW10UTED4)	11,0	Y1005J	7957	56
Phedra 2.0 D Multijet		2.0	100	4	09.06-11.10	RHR (DW10BTED4)	11,0	Y1005J	7957	56
Phedra 2.2 JTD (Engine No→9666)		2.2	94	4	09.02-05.03	4HW (DW12ATED4)	11,0	Y-504J	1441	24
Phedra 2.2 JTD		2.2	94	4	06.03-	DW12ATED4, 4HW	11,0	Y-504J	1441	24
Phedra 2.2 JTD		2.2	120	4	04.06-11.10	4HP, 4HR	11,0	YE08	4966	
Phedra 2.2 D MJET		2.2	125	4	02.08-11.10	4HT, 4HS	11,0	YE08	4966	

THEMA

Thema TD		2.4	74	4	01.93-		11,0	Y-924J	7906	1
Thema TD		2.5	85		01.94-12.94		11,0	Y-926U	7119	

THESIS

Thesis 2.4 JTD		2.4	110	5	07.02-04.03	841C000	11,0	Y-534J	3413	36
Thesis 2.4 JTD 20V		2.4	120	5	05.03-10.03	841M000, 841N000	11,0	YE07	6092	



e kW C
Y
IStock-No
D-POWER**LANCIA****THESIS**

Thesis 2.4 JTD 20V	2.4	129	5	05.03-06.09	841G000, 841H000	11,0	YE07	6092	
Thesis 2.4 D MJET 20V	2.4	136	5	09.05-06.09	841P000	11,0	YE07	6092	

YPSILON

Ypsilon 1.3 (For OE-No. 55238404)	312YXE1A	1.3	57	4	06.16-	199B1000	4,3	Y9001AS	97719	72
-----------------------------------	----------	-----	----	---	--------	----------	-----	---------	-------	----

YPSILON (843)

Ypsilon MJT	843	1.3	51	4	10.03- .06	188A4000	11,0	Y8003J	97256	62
Ypsilon 1.3 D MJET (843) (Euro 4)	843	1.3	55	4	09.06-	199A2000	11,0	Y8003J	97256	62
Ypsilon 1.3 D MJET (Euro 5)	843	1.3	55	4	.11-	199A2000	4,3	Y9001AS	97719	72
Ypsilon 1.3 D MJET	843	1.3	66	4	09.06-	199A3000	4,3	Y9001AS	97719	72
Ypsilon 1.3 D MJET	843	1.3	77	4	09.07-	199A3000	4,3	Y9001AS	97719	72

YPSILON (846)

Ypsilon 1.3 D Multijet	846	1.3	70	4	05.11-	199B1000	4,3	Y9001AS	97719	72
------------------------	-----	-----	----	---	--------	----------	-----	---------	-------	----

ZETA

Zeta TD		1.9	68	4	04.95-	XUD 9TE	11,0	Y-924J	7906	1
Zeta 2.0 JTD	220AR5OOL	2.0	81	4	04.01-10.03	RHW	11,0	Y-504J	1441	24
Zeta TD		2.1	80	4	07.96-	XUD11ATE	11,0	Y-924J	7906	1

LAND ROVER**COUNTRY**

Country TD		2.5	83	4	01.89-		11,0	Y-909R	4602	
------------	--	-----	----	---	--------	--	------	--------	------	--

DEFENDER

Defender TDI		2.5	83	4	11.89-10.98	200, 300 Gemini 1	11,5	Y-729U	4119	34
Defender 2.5 Td5		2.5	90	4	11.98-09.07	Td5	11,0	Y-605J	4309	
Defender TDI 90 & 110		2.5	102	4	01.99-		11,0	Y-924J	7906	1

DISCOVERY

Discovery TDi ES		2.5	83	4	09.89-		11,5	Y-729U	4119	34
Discovery TDI		2.5	83	4	09.89-01.99	200, 300 Gemini 1	11,5	Y-729U	4119	34
Discovery TDi Vogue ES		2.5	90	4	10.93-08.98		11,5	Y-729U	4119	34
Discovery 2.5 Td5		2.5	102	4	09.98-08.04	Td5	11,0	Y-605J	4309	

FREELANDER

Freelander TDI		2.0	71	4	10.97-08.98	20 T2R	11,0	Y-730U	6704	17
Freelander TD4		2.0	80	4	08.98-	M47D20 (BMW)	11,0	Y-507J	2691	32
Freelander TDI		2.5	102	5	05.98-		11,0	Y-924J	7906	1

FREELANDER 2

Freelander 2 2.2 TD4 (Chassis No->AH999999)		2.2	110	4	08.10-	DW12BTED4	11,0	YE08	4966	
Freelander 2 2.2 TD4 (Chassis No->AH999999)		2.2	112	4	01.07-	224DT	11,0	YE08	4966	
Freelander 2 2.2 TD4 (Chassis No->AH999999)		2.2	118	4	10.06-	224DT	11,0	YE08	4966	
Freelander 2 2.2 TD4 (Chassis No->AH999999)		2.2	140	4	08.10-		11,0	YE08	4966	

RANGE ROVER

Range Rover TDI		2.5	83	4	01.86-12.94	ETC 9091 N	11,5	Y-729U	4119	34
Range Rover Vogue TD		2.5	87	4	01.90-09.94	VM 425 SLIRR	11,0	Y-924J	7906	1
Range Rover Vogue TD		2.5	87	4	01.90-09.94	VM HR-492	11,0	Y-924J	7906	1
Range Rover		2.5	100	6	09.94-	M51 D25 (BMW)	11,0	Y-924J	7906	1
Range Rover 3		3.0	130	6	03.02-	M57 D30 BMW	11,0	Y-507J	2691	32





e kW C
y i



Stock-No
D-POWER

LAND ROVER

RANGE ROVER

Range Rover 3	3.0		6	.02-	M57 D30 (BMW)		11,0	Y-507J	2691	32
---------------	-----	--	---	------	---------------	--	------	--------	------	----

LANDROVER

DISCOVERY

Discovery Sport 2.0 TD4/TD4 E-Capability eD4/eD4 E-Capability	L550	2.0	110	4	12.14-	204DTD		7,0	CZ552	92738
Discovery Sport 2.0 TD4/TD4 E-Capability	L550	2.0	132	4	06.15-	204DTD		7,0	CZ552	92738
Discovery 2.0 TD4	L462	2.0	132	4	09.16-	204DTD		7,0	CZ552	92738
Discovery 2.0 SD4	L462	2.0	177	4	09.16-	204DTA		7,0	CZ552	92738

EVOQUE

Range Rover Evoque 2.0 eD4 E-Capability, TD4, TD4 E-Capability	L538	2.0	110	4	06.15-	AJ200D		7,0	CZ552	92738
Range Rover Evoque 2.0 TD4	L538	2.0	132	4	05.15-	AJ200D		7,0	CZ552	92738

RANGE ROVER

Range Rover Velar 2.0	L560	2.0	132	4	03.17-	204DTD		7,0	CZ552	92738
Range Rover Sport 2.0 SD4	L494	2.0	177	4	10.16-	204DTA		7,0	CZ552	92738
Range Rover Velar 2.0	L560	2.0	177	4	03.17-	204DTA		7,0	CZ552	92738

LEXUS

IS II

IS 2.2 D-4D	ALE20	2.2	110	4	07.10-07.12	2ADFTV		11,0	Y1012J	92083	65
IS 2.2 D-4D	ALE20	2.2	130	4	08.05-04.13	2ADFHV		11,0	Y1012J	92083	65

LX 450D

LX 450d 4.5 VVTi	VDJ201	4.5	200	8	09.15-	1VD-FTV		11,0	Y1012J	92083	65
------------------	--------	-----	-----	---	--------	---------	--	------	--------	-------	----

MAHINDRA

CJ 340 CLASSIC

CJ 340 Classic D		2.1	48	4	.93-	XD 4.90		11,0	Y-208T	1250
------------------	--	-----	----	---	------	---------	--	------	--------	------

CJ 540

CJ 540 D		2.1	48	4	.93-	XD 4.90		11,0	Y-208T	1250
----------	--	-----	----	---	------	---------	--	------	--------	------

MAZDA

121

121		1.8	44	4	03.96-	RTJ, RTK		11,5	Y-910J	3617	3
-----	--	-----	----	---	--------	----------	--	------	--------	------	---

2

2 Di Turbo DY (VIN 3*00001-→)		1.4	50	4	04.03- .07	MZ-CD-SOHC F6JA		11,0	YE04	1684	40
2 1.4 MZ-CD		1.4	50	4	.07-	F6JA		11,0	YE04	1684	40
2 1.5	DJ6H	1.5	77	4	12.14-	S5Y2		7,0	CZ165	93218	87

3

3 1.5	BM	1.5	77	4	12.15-	S5Y8		7,0	CZ165	93218	87
3 2.0 MZR-CD	BK	2.0	105	4	09.07-01.09	RF7J		11,0	Y-529J	4664	

323

323 TD BF (VIN →300001)		1.7	60	4	.99-	4EE1-T		11,0	Y-603J	8838	60
323 F	BJ	2.0	100	4	10.00-10.03	RF4F		11,0	Y-529J	4664	

5

5	CR19	2.0	81	4	02.05-05.10	RF7J		11,0	Y-529J	4664	
5	CR19	2.0	105	4	02.05-05.10	RF7J		11,0	Y-529J	4664	





l kW C
y i



Stock-No
D-POWER

MAZDA

6

6 2.0 DI	GG	2.0	89	4	10.02-09.07	RF5C	11,0	Y-529J	4664	
6 2.0 DI	GG	2.0	100	4	10.02-09.07	RF5C	11,0	Y-529J	4664	
6 2.0 DI	GG	2.0	105	4	03.05-09.05	RF7J	11,0	Y-529J	4664	
6 2.2 D Skyactiv-D 150 i-ELOOP	GJ2, GJ9	2.2	110	4	10.12-	SHY1	7,0	CZ163	92703	82
6 2.2 D Skyactiv-D 175 i-ELOOP	GJ2, GJ9	2.2	129	4	10.12-	SHY1	7,0	CZ163	92703	82

626

626 2.0 DITD	GF	2.0	66	4	04.98-10.02	RF3F	11,0	Y-529J	4664	
626 2.0 Turbo DI	GF	2.0	74	4	04.98-10.02	RF2A	11,0	Y-529J	4664	
626 DITD GF (VIN 186527→)		2.0	74	4	09.98-	RF	11,0	Y-529J	4664	
626 DITD Kombi GF (VIN 116329→)		2.0	74	4	09.98-	RF	11,0	Y-529J	4664	
626 2.0 TD	GF	2.0	81	4	10.00-10.02	RF4F	11,0	Y-529J	4664	

B 2200

B 2200		2.0		4	08.84-	F 2	10,5	Y-107R	1229	
B 2200		2.2		4	01.85-10.96	R 2	10,5	Y-107R	1229	

B 2500

B2500 TD		2.5	57	4	06.99-07.06	WLF1	11,0	CZ262	90919	
B2500 TD		2.5	62	4	06.99-07.06	WLF2	11,0	CZ262	90919	
B2500		2.5	80	4	09.98-07.06	WL81	11,0	CZ262	90919	
B2500		2.5	80	4	12.02-07.06	WLE7	11,0	CZ262	90919	
B2500 TD		2.5		4	06.99-07.06	WL84	11,0	CZ262	90919	

BT-50

BT-50 2.5 MRZ-CD	CD	2.5	105	4	08.06-	WLAA	11,0	Y-526J1	93283	69
BT-50 3.0 CDVi	CD	3.0	115	4	10.06-	WEAT	11,0	Y-526J1	93283	69

CX-3

CX3	DK	1.5	77	4	02.15-	S5Y5	7,0	CZ165	93218	87
-----	----	-----	----	---	--------	------	-----	-------	-------	----

CX-5

CX-5 2.2 D Skyactiv-D 150	KE	2.2	110	4	02.12-	SHY1	7,0	CZ163	92703	82
CX-5 2.2 D Skyactiv-D 175	KE	2.2	129	4	04.12-	SHY1	7,0	CZ163	92703	82

E 2000

E 2000		2.0		4	.93-	RF	10,5	Y-107R	1229	
--------	--	-----	--	---	------	----	------	--------	------	--

E 2200

E 2200		2.2		4	02.83- .92	F2	10,5	Y-107R	1229	
E 2200		2.2		4	.93- .96	R2	10,5	Y-107R	1229	

E 3000

E 3000		3.0			.93-	L4DE	11,0	Y-721RS	3687	
E 3000		3.0			.93-	VS	11,0	Y-721RS	3687	

MPV

MPV		2.0	100	4	.97-06.02	WLT	11,0	Y-701J	1566	39
-----	--	-----	-----	---	-----------	-----	------	--------	------	----

PREMACY

Premacy 2.0 TD	CP	2.0	66	4	03.99-03.00	RF3F	11,0	Y-529J	4664	
Premacy 2.0 TD	CP	2.0	74	4	07.00-06.05	RF4F	11,0	Y-529J	4664	

T 3000

T 3000		3.0			.93-	HA	24,0	Y-771R	4262	
T 3000		3.0			.93-	L4DE	24,0	Y-771R	4262	





e kW C
y
i



Stock-No
D-POWER

MAZDA

T SERIE

T Serie				.97-	VS		24,0	Y-771R	4262	
---------	--	--	--	------	----	--	------	--------	------	--

MERCEDES

190 (W201)

190 D	201	2.0	53	4	02.89-05.93	OM 601.911		11,5	Y-916J	5906	6
190 D	201	2.5	66	5	02.89-05.93	OM 602.911		11,5	Y-916J	5906	6
190 D	201	2.5	90	5	02.89-05.93	OM 602.961		11,5	Y-916J	5906	6
190 DT	201	2.5	90	5	02.89-05.93	OM 602.961		12,0	Y-918J	6285	2

250 (W124)

250 D, 250 TD	124	2.5	66	5	02.89-06.93	OM 602.912		11,5	Y-916J	5906	6
---------------	-----	-----	----	---	-------------	------------	--	------	--------	------	---

300 (W124)

300 TD	124	3.0	92	6	02.89-06.93	OM 603.960		11,5	Y-916J	5906	6
300 TD 4Mat.	124	3.0	105	6	02.89-06.93	OM 603.963		11,5	Y-916J	5906	6
300 TD	124	3.0	108	6	02.89-06.93	OM 603.960		11,5	Y-916J	5906	6

A-CLASS (168)

A 160 CDI	168	1.7	44	4	10.97-02.01	OM 668.941		11,5	Y-746J	3078	38
A 160 CDI	168	1.7	55	4	02.01-08.04	OM 668.940		11,5	Y-746J	3078	38
A 170 CDI	168	1.7	66	4	08.98-02.01	OM 668.940		11,5	Y-746J	3078	38
A 170 CDI	168	1.7	70	4	02.01-08.04	OM 668.942		11,5	Y-746J	3078	38

A-CLASS (169)

A 160 CDI	169	2.0	60	4	09.04-	OM 640.942		4,4	Y8002AS	6287	51
A 180 CDi	169	2.0	80	4	09.04-	OM 640.940		4,4	Y8002AS	6287	51
A 200 CDi	169	2.0	103	4	09.04-06.12	OM 640.941		4,4	Y8002AS	6287	51
A 200 2.0 CDi (Euro 5)	169	2.0	100	4	09.04-06.12	OM 640.941		7,0	CZ303	7865	54

A-CLASS (176)

A 160 CDI	176	1.5	66	4	06.13-	OM 607.951		4,4	Y1035AS	94103	54
A 180 CDI	176	1.5	80	4	06.12-	OM 607.951		4,4	Y1035AS	94103	54
A 180 CDI	176	1.8	80	4	06.12-	OM 651.901		7,0	CZ303	7865	54
A 200 CDI	176	1.8	100	4	06.12-	OM 651.901		7,0	CZ303	7865	54
A 200 CDI	176	2.2	100	4	02.14-	OM 651.930		7,0	CZ551	91584	54
A 220 CDI	176	2.2	120	4	01.14-	OM 651.930		7,0	CZ551	91584	54
A 220 CDI	176	2.2	125	4	06.12-	OM 651.930		7,0	CZ303	7865	54
A 220 CDI 4-matic	176	2.2	125	4	02.14-	OM 651.930		7,0	CZ551	91584	54

B-CLASS (245)

B 180 CDI	245	2.0	80	4	04.05-10.07	OM 640.940		4,4	Y8002AS	6287	54
B 180 CDI	245	2.0	80	4	11.07- .11	OM 640.940		7,0	CZ303	7865	54
B 200 CDI	245	2.0	100	4	04.05-11.07	OM 640.941		4,4	Y8002AS	6287	54
B 200 CDI	245	2.0	100	4	12.07- .11	OM 640.941		7,0	CZ303	7865	54
B 200 CDI	245	2.0	103	4	04.05-11.07	OM 640.941		4,4	Y8002AS	6287	54
B 200 CDI	245	2.0	103	4	12.07- .11	OM 640.941		7,0	CZ303	7865	54

B-CLASS (246)

B 160 CDI	246	1.5	66	4	05.13-	OM 607.951		4,4	Y1035AS	94103	54
B 180 CDI	246	1.5	80	4	02.13-	OM 607.951		4,4	Y1035AS	94103	54
B 180 CDI	246	1.8	80	4	11.11-	OM 651.901		7,0	CZ303	7865	54
B 200 CDI	246	1.8	100	4	11.11-	OM 651.901		7,0	CZ303	7865	54
B 220 CDI	246	2.2	120	4	06.13-	OM 651.930		7,0	CZ551	91584	54





l kW C
y
i



Stock-No
D-POWER

MERCEDES

B-CLASS (246)

B 220 CDI	246	2.2	125	4	11.11-	OM 651.930	7,0	CZ303	7865	54
B 220 CDI	246	2.2	130	4	09.14-	OM 651.930	7,0	CZ551	91584	54

C-CLASS (202)

C 180 D	202	1.8	65	4	10.98-05.00	OM 604..	11,5	Y-925J	6848	54
C 200 D	202	2.0	55	4	07.93-05.00	OM 601.913	11,5	Y-916J	5906	54
C 200 D	202	2.0	65	4	10.96-05.00	OM 604.915	11,5	Y-925J	6848	54
C 200 CDI	202	2.2	75	4	03.98-05.00	OM 611.960	11,5	Y-745U	6346	54
C 220 D	202	2.2	70	4	07.93-05.95	OM 604.910	11,5	Y-930U	4275	54
C 220 D	202	2.2	70	4	06.95-05.00	OM 604.910	11,5	Y-925J	6848	54
C 220 CDI	202	2.2	75	4	06.98-05.00	OM 611.961	11,5	Y-745U	6346	54
C 220 CDI	202	2.2	92	4	09.97-03.01	OM 611.960	11,5	Y-745U	6346	54
C 250 D	202	2.5	83	5	07.93-01.95	OM 605.910	11,5	Y-930U	4275	54
C 250 D	202	2.5	83	5	02.95-08.95	OM 605.910	11,5	Y-925J	6848	54
C 250 Td	202	2.5	110	5	05.96-05.00	OM 605.960	11,5	Y-925J	6848	54

C-CLASS (203)

C 200 CDI	203	2.2	75	4	03.01-03.03	OM 646.962	11,5	Y-745U	6346	54
C 200 CDI	203	2.2	85	4	05.00-03.04	OM 611.962	11,5	Y-745U	6346	54
C 200 CDI	203	2.2	90	4	04.03-03.07	OM 646.962	11,5	Y-745U	6346	54
C 220 CDI	203	2.2	105	4	05.00-12.04	OM 611.962	11,5	Y-745U	6346	54
C 220 CDI	203	2.2	110	4	04.03-10.07	OM 646.963	11,5	Y-745U	6346	54
C 270 CDI	203	2.7	125	5	12.00-12.04	OM 612.962	11,5	Y-745U	6346	54
C 320 CDi	203	3.0	165	6	01.05-11.07	OM 642.910	4,4	Y8002AS	6287	54

C-CLASS (204)

C 180 CDI	204	2.2	88	4	01.10-	OM 651.913	7,0	CZ303	7865	54
C 200 CDI	204	2.2	100	4	08.07-12.09	OM 646.811	7,0	CZ106	9957	54
C 200 CDI	204	2.2	100	4	01.10-	OM 651.913	7,0	CZ303	7865	54
C 200 CDI ECO	204	2.2		4	10.07-12.09	OM 646.812	7,0	CZ106	9957	54
C 220 CDI (Euro 3 / Euro 4 / Euro 5)	204	2.2	120	4	01.07-01.14	OM 651.911	7,0	CZ303	7865	54
C 220 CDI (Euro 6)	204	2.2	120	4	01.07-01.14	OM 651.911	7,0	CZ551	91584	54
C 220 CDI	204	2.2	125	4	05.07-11.08	OM 646.811	7,0	CZ106	9957	54
C 220 CDI	204	2.2	125	4	12.08-	OM 651.911	7,0	CZ303	7865	54
C 220 CDI 4-matic (Euro 5)	204	2.2	125	4	02.13-01.14	OM 651.912	7,0	CZ303	7865	54
C 220 CDI 4-matic (Euro 6)	204	2.2	125	4	02.13-01.14	OM 651.912	7,0	CZ551	91584	54
C 220 CDI	204	2.2	150	4	12.08-	OM 651.911	7,0	CZ303	7865	54
C 250 CDI	204	2.2	150	4	01.08-	OM 651.911	7,0	CZ303	7865	54
C 250 CDI 4-matic	204	2.2	150	4	01.11-	OM 651.912	7,0	CZ303	7865	54
C 300 CDi/CDi BlueEFFICIENCY	204	3.0	170	6	01.11-01.14	OM 642.832	7,0	CZ303	7865	54
C 320 Cdi Production Date 15.8.2013→	204	3.0	165	6	02.07-08.13	OM 642.960	4,4	Y8002AS	6287	54
C 320 Cdi Production Date 15.8.2013→	204	3.0	165	6	05.07-08.13	OM 642.961	4,4	Y8002AS	6287	54
C 320 CDi	204	3.0	165	6	11.07-12.10	OM 642.960	4,4	Y8002AS	6287	54
C 320 CDi	204	3.0	165	6	05.08-12.10	OM 642.961	4,4	Y8002AS	6287	54
C 320 Cdi (Production Date→ 15.8.2013)	204	3.0	165	6	08.13-01.14	OM 642.960	7,0	CZ303	7865	54
C 320 Cdi (Production Date→ 15.8.2013)	204	3.0	165	6	08.13-01.14	OM 642.961	7,0	CZ303	7865	54
C 350 CDi/CDi BlueEFFICIENCY	204	3.0	165	6	02.07-01.14	OM 642.830	7,0	CZ303	7865	54



e kW C
y iStock-No
D-POWER**MERCEDES****C-CLASS (204)**

C 350 CDi/CDi BlueEFFICIENCY (15.8.2013→Production Date)	204	3.0	165	6	02.07-08.13	OM 642.960	4,4	Y8002AS	6287	54
C 350 CDi/CDi BlueEFFICIENCY	204	3.0	165	6	05.07-12.11	OM 642.832	7,0	CZ303	7865	54
C 350 CDi/CDi BlueEFFICIENCY	204	3.0	165	6	05.07-12.11	OM 642.961	4,4	Y8002AS	6287	54
C 350 CDi/CDi BlueEFFICIENCY	204	3.0	165	6	11.07-12.11	OM 642.830	7,0	CZ303	7865	54
C 350 CDi/CDi BlueEFFICIENCY	204	3.0	165	6	11.07-12.11	OM 642.960	4,4	Y8002AS	6287	54
C 350 CDi	204	3.0	165	6	05.08-12.11	OM 642.832	7,0	CZ303	7865	54
C 350 CDi	204	3.0	165	6	05.08-12.11	OM 642.961	4,4	Y8002AS	6287	54
C 350 CDi/CDi BlueEFFICIENCY (Production Date→ 15.8.2013)	204	3.0	165	6	08.13-01.14	OM 642.960	7,0	CZ303	7865	54
C 350 CDi BlueEFFICIENCY	204	3.0	170	6	07.09-01.14	OM 642.830	7,0	CZ303	7865	54
C 350 CDi BlueEFFICIENCY	204	3.0	170	6	07.09-01.14	OM 642.832	7,0	CZ303	7865	54
C 350 CDi/CDi BlueEFFICIENCY (Engine No→41324858)	204	3.0	195	6	06.11-05.12	OM 642.834	7,0	CZ159	95398	54
C 350 CDi/CDi BlueEFFICIENCY	204	3.0	195	6	06.11-01.14	OM 642.834	7,0	CZ303	7865	54

C-CLASS (205)

C 220 BlueTEC (Euro 5)	205	2.2	125	4	12.13-	OM 651.921	7,0	CZ303	7865	54
C 220 BlueTEC (Euro 6)	205	2.2	125	4	12.13-	OM 651.921	7,0	CZ551	91584	54
C 220 CDI Blue Efficiency	205	2.2	120	4	12.13-	OM 651.921	7,0	CZ551	91584	54
C 250 BlueTEC (Euro 5)	205	2.2	150	4	02.14-	OM 651.921	7,0	CZ303	7865	54
C 250 BlueTEC (Euro 6)	205	2.2	150	4	02.14-	OM 651.921	7,0	CZ551	91584	54
C 300 BlueTEC Hybrid	205	2.2	150	4	05.14-	OM 651.921	7,0	CZ551	91584	54

C-COUPÉ (203)

CLC 200 CDI	203	2.2	90	4	05.08-	OM 646.962	11,5	Y-745U	6346	54
CLC 220 CDI	203	2.2	110	4	05.08-	OM 646.963	11,5	Y-745U	6346	54

CLA (117)

CLA 180 CDI	117	1.5	80	4	10.13-	OM 607.951	4,4	Y1035AS	94103	54
CLA 200 CDI	117	1.8	100	4	06.13-	OM 651.901	7,0	CZ303	7865	54
CLA 200 CDI	117	2.2	100	4	07.14-	OM 651.930	7,0	CZ551	91584	54
CLA 220 CDI	117	2.2	125	4	01.13-	OM 651.930	7,0	CZ303	7865	54
CLA 220 CDI 4-matic	117	2.2	125	4	07.14-	OM 651.930	7,0	CZ551	91584	54
CLA 220 CDI	117	2.2	130	4	07.14-	OM 651.930	7,0	CZ551	91584	54

CLK (209)

CLK 220 CDI	209	2.2	110	4	01.05-	OM 646.963	11,5	Y-745U	6346	54
CLK 220 CDI	209	2.2	110	4	01.05-	OM 646.966	11,5	Y-745U	6346	54
CLK 270 CDI	209	2.7	125	5	10.02-07.05	OM 612.962	11,5	Y-745U	6346	54
CLK 270 CDI	209	2.7	125	5	10.02-07.05	OM 612.967	11,5	Y-745U	6346	54
CLK 320 CDi	209	3.0	165	6	03.05-12.10	OM 642.910	4,4	Y8002AS	6287	54

CLS (204)

C 220 2.2 CDi BlueEFFICIENCY	204	2.2	120	4	06.11-01.14	OM 651.911	7,0	CZ303	7865	54
C 300 3.0 CDi/CDi BlueEFFICIENCY	204	3.0	170	6	01.11-01.14	OM 642.832	7,0	CZ303	7865	54
C350 3.0 CDi/CDi BlueEFFICIENCY	204	3.0	165	6	02.07-01.14	OM 642.830	7,0	CZ303	7865	54
C350 3.0 CDi/CDi BlueEFFICIENCY	204	3.0	165	6	05.07-12.11	OM 642.832	7,0	CZ303	7865	54
C 350 3.0 CDi	204	3.0	165	6	08.07-12.11	OM 642.832	7,0	CZ303	7865	54
C 350 3.0 CDi/CDi BlueEFFICIENCY	204	3.0	165	6	11.07-12.11	OM 642.830	7,0	CZ303	7865	54

CLS (205)

C 220 2.2	205	2.2	120	4	10.15-05.18	OM 651.921	7,0	CZ303	7865	54
-----------	-----	-----	-----	---	-------------	------------	-----	-------	------	----





 kW
 C
 Y
 I



Stock-No
 D-POWER

MERCEDES

CLS (205)

C 220 2.2	205	2.2	120	4	06.16-05.18	OM 651.921	7,0	CZ303	7865	54
C220 2.2 BlueTec 2-4	205	2.2	125	4	04.15-05.18	OM 651.921	7,0	CZ303	7865	54
C 220 2.2	205	2.2	125	4	04.16-05.18	OM 651.921	7,0	CZ303	7865	54
C 220 2.2	205	2.2	125	4	06.16-05.18	OM 651.921	7,0	CZ303	7865	54
C 250 2.2	205	2.2	150	4	04.16-05.18	OM 651.921	7,0	CZ303	7865	54
C 250 2.2	205	2.2	150	4	06.16-05.18	OM 651.921	7,0	CZ303	7865	54

CLS (218)

CLS 220 2.2 BlueTec	218	2.2	120	4	05.14-12.17	OM 651.924	7,0	CZ303	7865	54
CLS 220 2.2 BlueTec	218	2.2	125	4	05.14-12.17	OM 651.924	7,0	CZ303	7865	54
CLS 250 CDI	218	2.2	150	4	10.10-	OM 651.924	7,0	CZ303	7865	54
CLS 250 BlueTEC 4-matic	218	2.2	150	4	05.14-	OM 651.924	7,0	CZ551	91584	85
CLS 350 BlueTec	218	3.0	185	6	02.13-	OM 642.858	7,0	CZ303	7865	54
CLS 350 BlueTec	218	3.0	185	6	05.14-	OM 642.852	7,0	CZ303	7865	54
CLS 350 BlueTec	218	3.0	190	6	06.14-	OM 642.853	7,0	CZ303	7865	54
CLS 350 BlueTec	218	3.0	190	6	04.15-	OM 642.854	7,0	CZ303	7865	54
CLS 350 BlueTec	218	3.0	190	6	04.15-	OM 642.858	7,0	CZ303	7865	54
CLS 350 CDI/CDi BlueEFFICIENCY (Engine No->41324858)	218	3.0	195	6	01.11-05.12	OM 642.853	7,0	CZ159	95398	84
CLS 350 CDI/CDi BlueEFFICIENCY (Engine No->41324858)	218	3.0	195	6	01.11-05.12	OM 642.854	7,0	CZ159	95398	84
CLS 350 CDI/CDi BlueEFFICIENCY	218	3.0	195	6	01.11-	OM 642.853	7,0	CZ303	7865	54
CLS 350 CDI/CDi BlueEFFICIENCY	218	3.0	195	6	09.11-	OM 642.854	7,0	CZ303	7865	54

CLS (219)

CLS 320 CDi	219	3.0	155	6	01.05-12.10	OM 642.920	4,4	Y8002AS	6287	51
CLS 320 3.0 CDi (Country-version: USA)	219	3.0	155	6	01.05-12.10	OM 642.920	7,0	CZ303	7865	54
CLS 350 CDi	219	3.0	203	6	04.09-12.10	OM 642.920	4,4	Y8002AS	6287	51

E-CLASS (124)

E 200 D	124	2.0	53	4	07.93-05.95	OM 601.912	11,5	Y-916J	5906	6
E 250 D	124	2.5	66	5	07.93-	OM 602.912, OM 602.962	11,5	Y-916J	5906	6
E 250 T, TD	124	2.5	66	5	07.93-	OM 602.962	11,5	Y-916J	5906	6
E 250 D	124	2.5	83	5	07.93-04.96	OM 605.911, OM 605.912	11,5	Y-925J	6848	16
E 250 D	124	2.5	83	5	07.93-05.95	OM 605.911	11,5	Y-930U	4275	30
E 250 TD	124	2.5	93	5	07.93-05.95	OM 602.962	11,5	Y-916J	5906	6
E 300 D	124	3.0	100	6	07.93-05.95	OM 606.910	11,5	Y-930U	4275	30
E 300 TD	124	3.0	100	6	07.93-05.95	OM 606.910	11,5	Y-930U	4275	30
E 300 TD	124	3.0	100	6	06.95-06.96	OM 606.910	11,5	Y-925J	6848	16
E 300 TD	124	3.0	108	6	07.93-	OM 603.960	11,5	Y-916J	5906	6

E-CLASS (207)

E 220 2.2 BlueTec	207	2.2	130	4	05.14-12.16	OM 651.911	7,0	CZ303	7865	54
E 350 CDi	207	3.0	170	6	01.09-	OM 642.836	7,0	CZ303	7865	54
E 350 BlueTec	207	3.0	185	6	03.13-	OM 642.838	7,0	CZ303	7865	54
E 350 CDi BlueTec	207	3.0	185	6	03.13-	OM 642.838	7,0	CZ303	7865	54
E 350 BlueTec	207	3.0	190	6	05.14-	OM 642.838	7,0	CZ303	7865	54
E 350 CDi BlueEFFICIENCY (Engine No->41324858)	207	3.0	195	6	04.11-05.12	OM 642.838	7,0	CZ159	95398	84
E 350 CDi BlueEFFICIENCY	207	3.0	195	6	04.11-	OM 642.838	7,0	CZ303	7865	54





e kW C
y
i



Stock-No
D-POWER™

MERCEDES

E-CLASS (210)

E 200 D	210	2.0	65	4	01.96-03.02	OM 604.917	11,5	Y-925J	6848	16
E 200 CDI	210	2.2	75	4	06.98-06.99	OM 611.961	11,5	Y-745U	6346	11
E 200 CDI	210	2.2	85	4	07.99-03.03	OM 611.961	11,5	Y-745U	6346	11
E 220 D	210	2.2	55	4	05.96-03.02	OM 611.913	11,5	Y-925J	6848	16
E 220 D	210	2.2	70	4	03.95-03.02	OM 604.912	11,5	Y-925J	6848	16
E 220 CDI	210	2.2	92	4	06.98-06.99	OM 611.961	11,5	Y-745U	6346	11
E 220 CDI	210	2.2	105	4	07.99-03.03	OM 611.961	11,5	Y-745U	6346	11
E 220 D	210	2.2	105	4	07.99-03.02	OM 611.962	11,5	Y-745U	6346	11
E 250 D	210	2.5	83	5	03.95-07.99	OM 605.912	11,5	Y-925J	6848	16
E 250 TD	210	2.5	110	5	06.97-07.99	OM 605.962	11,5	Y-925J	6848	16
E 270 CDI	210	2.7	105	5	07.99-03.03	OM 612.961	11,5	Y-745U	6346	11
E 290 TD	210	2.9	95	5	06.95-07.99	OM 602.982	11,5	Y-929U	1749	41
E 300 D	210	3.0	100	6	03.95-06.97	OM 606.912	11,5	Y-925J	6848	16
E 300 Td T	210	3.0	130	6	03.97-07.99	OM 606.962	11,5	Y-925J	6848	16
E 300 Td T	210	3.0	130	6	03.97-07.99	OM 606.962	11,5	Y-930U	4275	30
E 320 CDI	210	3.2	145	6	07.99-03.03	OM 613.961	11,5	Y-745U	6346	11

E-CLASS (211)

E 200 CDI	211	2.2	90	4	07.02-07.09	OM 646.951	11,5	Y-745U	6346	11
E 200 CDI	211	2.2	100	4	04.06-07.09	OM 646.820, OM 646.821	7,0	CZ106	9957	53
E 200 CDI	211	2.2	125	4	.06-07.09	OM 646.821	7,0	CZ106	9957	53
E 220 CDI	211	2.2	110	4	03.03-07.09	OM 646.961	11,5	Y-745U	6346	11
E 220 CDI	211	2.2	125	4	04.06-07.09	OM 646.821	7,0	CZ106	9957	53
E 280 3.0 CDi (Country-version: Japan, USA)	211	3.0	140	6	03.05-07.09	OM 642.921	7,0	CZ303	7865	54
E 270 CDI	211	2.7	130	5	03.03-07.09	OM 647.961	11,5	Y-745U	6346	11
E 280 CDi	211	3.0	140	6	03.05-12.11	OM 642.920	4,4	Y8002AS	6287	51
E 280 CDi	211	3.0	140	6	03.05-07.09	OM 642.921	4,4	Y8002AS	6287	51
E 280 3.0 CDi (Country-version: Japan, USA)	211	3.0	140	6	03.05-12.08	OM 642.921	7,0	CZ303	7865	54
E 280 CDi	211	3.2	130	6	05.04-07.09	OM 648.961	11,5	Y-745U	6346	11
E 320 CDi	211	3.0	165	6	03.05-07.09	OM 642.920	4,4	Y8002AS	6287	51
E 320 CDi	211	3.0	165	6	03.05-07.09	OM 642.921	4,4	Y8002AS	6287	51
E 320 3.0 CDi (Country-version: Japan, USA)	211	3.0	165	6	03.05-07.09	OM 642.921	7,0	CZ303	7865	54
E 320 CDi	211	3.2	150	6	03.03-07.09	OM 648.961	11,5	Y-745U	6346	11
E 400 CDi	211	4.0	191	8	02.03-07.09	OM 628.961	11,5	Y-745U	6346	11
E 420 CDi	211	4.0	231	8	09.05-07.09	OM 629.910	4,4	Y8002AS	6287	51
E 420 CDi	211	4.0	231	8	01.06-07.09	OM 629.910	4,4	Y8002AS	6287	51

E-CLASS (212)

E 200 CDi	212	2.2	100	4	05.09-	OM 651.925	7,0	CZ303	7865	54
E 220 CDi	212	2.2	125	4	03.09-	OM 651.924	7,0	CZ303	7865	54
E 220 2.2 CDi/CDi BlueEFFICIENCY	212	2.2	120	4	01.09-08.14	OM 651.924	7,0	CZ303	7865	54
E 220 2.2 CDi/CDi BlueEFFICIENCY/CDi BlueTec	212	2.2	120	4	01.09-12.15	OM 651.924	7,0	CZ303	7865	54
E 250 CDi	212	2.2	150	4	03.09-	OM 651.924	7,0	CZ303	7865	54
E 300 BlueTEC Hybrid (Euro 4 / Euro 5)	212	2.2	150	4	12.11-	OM 651.924	7,0	CZ303	7865	54
E 300 BlueTEC Hybrid (Euro 6)	212	2.2	150	4	12.11-	OM 651.924	7,0	CZ551	91584	85
E 300 Cdi	212	3.0	150	6	12.09-12.10	OM 642.850	7,0	CZ303	7865	54





 kW
 C
 Y
 I



Stock-No
 D-POWER

MERCEDES

E-CLASS (212)

E 300 BlueTec/CDi BlueEFFICIENCY (Engine No→41324858)	212	3.0	170	6	03.10-05.12	OM 642.852	7,0	CZ159	95398	84
E 300 BlueTec/CDi BlueEFFICIENCY	212	3.0	170	6	03.10-	OM 642.852	7,0	CZ303	7865	54
E 300 BlueTec/CDi BlueEFFICIENCY (Eng Nr.→41330714)	212	3.0	170	6	03.10-06.12	OM 642.850	7,0	CZ303	7865	54
E 300 BlueTec/CDi BlueEFFICIENCY (41330714→ Eng Nr.)	212	3.0	170	6	06.12-	OM 642.850	7,0	CZ303	7865	54
E 350 BlueTec/CDi BlueTec (Eng Nr.→41330714)	212	3.0	155	6	01.09-06.12	OM 642.850	7,0	CZ303	7865	54
E 350 BlueTec/CDi BlueTec (41330714→ Eng Nr.)	212	3.0	155	6	06.12-12.15	OM 642.850	7,0	CZ303	7865	54
E 350 CDi BlueEFFICIENCY	212	3.0	170	6	01.09-	OM 642.856	7,0	CZ303	7865	54
E 350 CDi BlueEFFICIENCY (Eng Nr.→41330714)	212	3.0	170	6	01.09-06.12	OM 642.850	7,0	CZ303	7865	54
E 350 CDi BlueEFFICIENCY (41330714→ Eng Nr.)	212	3.0	170	6	06.12-	OM 642.850	7,0	CZ303	7865	54
E 350 BlueTec	212	3.0	190	6	05.14-	OM 642.852	7,0	CZ303	7865	54
E 350 BlueTec	212	3.0	190	6	05.14-	OM 642.858	7,0	CZ303	7865	54
E 350 CDi BlueEFFICIENCY (Engine No→41324858)	212	3.0	195	6	03.11-05.12	OM 642.852	7,0	CZ159	95398	84
E 350 CDi BlueEFFICIENCY (Engine No→41324858)	212	3.0	195	6	03.11-05.12	OM 642.858	7,0	CZ159	95398	84
E 350 CDi BlueEFFICIENCY	212	3.0	195	6	03.11-	OM 642.852	7,0	CZ303	7865	54
E 350 CDi BlueEFFICIENCY	212	3.0	195	6	03.11-12.15	OM 642.858	7,0	CZ303	7865	54

E-CLASS (213)

E 350 CDi	213	3.0	190	6	01.16-	OM 642.855	7,0	CZ303	7865	54
-----------	-----	-----	-----	---	--------	------------	-----	-------	------	----

E-COUPÉ (207)

E 220 CDI Coupe / Cabriolet (Euro 4 / Euro 5)	207	2.2	120	4	02.10-	OM 651.911	7,0	CZ303	7865	54
E 220 CDI Coupe / Cabriolet (Euro 4 / Euro 5)	207	2.2	125	4	01.10-	OM 651.911	7,0	CZ303	7865	54
E 250 CDI Coupe / Cabriolet (Euro 4 / Euro 5)	207	2.2	150	4	01.10-	OM 651.911	7,0	CZ303	7865	54

G-CLASS (461)

290 GDT	461	2.9	72	6	08.93-00.94	OM 602.942, OM 602.947	11,5	Y-916J	5906	6
290 GDT	461	2.9	90	5	07.97-	OM 602.983	11,5	Y-929U	1749	41
G 300/G 280 3.0 CDi (Engine No 41330714→)	461	3.0	135	6	06.12-	OM 642.884	7,0	CZ303	7865	54
G 300/G 280 3.0 CDi (Engine No 41330714→)	461	3.0	135	6	06.12-	OM 642.975	7,0	CZ303	7865	54

G-CLASS (463)

G 280 Cdi (Eng Nr.→41330714)	463	3.0	135	6	04.09-06.12	OM 642.884	4,4	Y8002AS	6287	51
G 280 Cdi (41330714→ Eng Nr.)	463	3.0	135	6	06.12-12.12	OM 642.884	7,0	CZ303	7865	54
G 300 D	463	3.0	83	6	08.93-	OM 603.931	11,5	Y-916J	5906	6
G 300 TD	463	3.0	130	6	08.96-	OM 606.964	11,5	Y-925J	6848	16
G 300 Cdi (Eng Nr.→41330714)	463	3.0	135	6	04.10-06.12	OM 642.884	4,4	Y8002AS	6287	51
G 300 Cdi (41330714→ Eng Nr.)	463	3.0	135	6	06.12-	OM 642.884	7,0	CZ303	7865	54
G 320 Cdi	463	3.0	165	6	08.06-12.12	OM 642.970	7,0	CZ303	7865	54
G 350 BlueTec/CDi	463	3.0	155	6	07.11-	OM 642.886	7,0	CZ303	7865	54
G 350 CDi	463	3.0	165	6	06.09-12.15	OM 642.886	7,0	CZ303	7865	54
G 350 CDi	463	3.0	165	6	06.09-12.11	OM 642.970	7,0	CZ303	7865	54
G 350 BlueTec	463	3.0	180	6	06.15-	OM 642.887	7,0	CZ303	7865	54
G 350 3.0 BlueTec	463	3.0	155	6	07.11-	OM 642.886	7,0	CZ303	7865	54
G 350 3.0 BlueTec/BlueTec/Cdi	463	3.0	155	6	07.11-	OM 642.886	7,0	CZ303	7865	54
G 350 3.0 CDi	463	3.0	165	6	06.09-12.15	OM 642.886	7,0	CZ303	7865	54





e kW C
y i



Stock-No
D-POWER™

MERCEDES

G-CLASS (463)

G 350 3.0 CDI	463	3.0	165	6	06.09-12.11	OM 642.970	7,0	CZ303	7865	54
G 400 CDI	463	4.0	184	8	12.00-	OM 628.962	11,5	Y-745U	6346	11

GL (X164)

GL 320 CDI	164	3.0	155	6	12.09-08.12	OM 642.820	7,0	CZ303	7865	54
GL 320 3.0 CDI (Country-version: USA)	164	3.0	165	6	09.06-05.09	OM 642940	7,0	CZ303	7865	54
GL 350 BlueTec/CDi	164	3.0	155	6	06.09-08.12	OM 642.820	7,0	CZ303	7865	54
GL 350 BlueTec/CDi	164	3.0	155	6	06.09-08.12	OM 642.940	4,4	Y8002AS	6287	51
GL 350 Cdi	164	3.0	165	6	06.09-08.12	OM 642.940	4,4	Y8002AS	6287	51
GL 350 CDi BlueEFFICIENCY	164	3.0	195	6	10.10-08.12	OM 642.822	7,0	CZ303	7865	54
GL 350 CDi BlueEFFICIENCY (Engine No→41324858)	X164	3.0	195	6	10.10-05.12	OM 642.822	7,0	CZ159	95398	84
GL 420 CDI	X164	4.0	225	8	01.06-	OM 629.912	4,4	Y8002AS	6287	51
GL 450 CDI	X164	4.0	225	8	05.09-	OM 629.912	4,4	Y8002AS	6287	51

GL (X166)

GL 350 BlueTec	166	3.0	183	6	06.12-10.15	OM 642.826	7,0	CZ303	7865	54
GLS 350	166	3.0	190	6	11.15-	OM 642.826	7,0	CZ303	7865	54

GLC (253)

GLC 220 2.2	253	2.2	120	4	06.16-04.19	OM 651921	7,0	CZ303	7865	54
GLC 220 2.2	253	2.2	120	4	06.15-04.19	OM 651921	7,0	CZ303	7865	54

GLE (212)

GLE 350	212	3.0	190	6	03.15-10.19	OM 642.826	7,0	CZ159	95398	84
---------	-----	-----	-----	---	-------------	------------	-----	-------	-------	----

GLK (292)

GLK 350 CDi/CDi BlueEFFICIENCY	X204	3.0	195	6	07.12-06.15	OM 642.835	7,0	CZ159	95398	84
--------------------------------	------	-----	-----	---	-------------	------------	-----	-------	-------	----

GLK (X204)

GLK 200 CDI (Euro 5)	X204	2.2	100	4	12.13-	OM 651.916	7,0	CZ303	7865	54
GLK 200 CDI (Euro 6)	X204	2.2	100	4	12.13-	OM 651.916	7,0	CZ551	91584	85
GLK 200 CDI (Euro 5)	X204	2.2	105	4	07.10-	OM 651.913, OM 651.916	7,0	CZ303	7865	54
GLK 200 CDI (Euro 6)	X204	2.2	105	4	07.10-	OM 651.913, OM 651.916	7,0	CZ551	91584	85
GLK 220 CDI	X204	2.2	120	4	06.08-	OM 651.912	7,0	CZ303	7865	54
GLK 220 CDI	X204	2.2	120	4	06.08-	OM 651.916	7,0	CZ303	7865	54
GLK 220 CDI	X204	2.2	125	4	06.08-	OM 651.912	7,0	CZ303	7865	54
GLK 220 CDI	X204	2.2	125	4	08.08-	OM 651.916	7,0	CZ303	7865	54
GLK 250 CDI	X204	2.2	150	4	10.08-	OM 651.912	7,0	CZ303	7865	54
GLK 320 Cdi (15.8.2013→Production Date)	X204	3.0	165	6	06.08-08.13	OM 642.961	4,4	Y8002AS	6287	51
GLK 320 Cdi (Production Date→15.8.2013)	X204	3.0	165	6	08.13-	OM 642.961	7,0	CZ303	7865	54
GLK 350 CDi	X204	3.0	165	6	07.09-01.10	OM 642.832	7,0	CZ303	7865	54
GLK 350 CDi/CDi BlueEFFICIENCY	X204	3.0	195	6	07.12-	OM 642.835	7,0	CZ303	7865	54

MARCO POLO W447

MARCO POLO 160 1.6 CDi	447	1.6	65	4	03.15-	OM 622951	4,5	Y1010AS	91210	88
MARCO POLO 180 1.6 CDi	447	1.6	84	4	03.15-	OM 622951	4,5	Y1010AS	91210	88
MARCO POLO 200 2.2 CDi/CDi BlueEFFICIENCY	447	2.2	100	4	03.15-	OM 651950	7,0	CZ303	7865	54
MARCO POLO 220 2.2 CDi/CDi BlueEFFICIENCY	447	2.2	120	4	03.15-	OM 651950	7,0	CZ303	7865	54
MARCO POLO 250 2.2 BlueTec BlueEFFICIENCY/CDi BlueEFFICIENCY	447703, 447813	2.2	140	4	03.15-	OM 651950	7,0	CZ303	7865	54



e kW C
Y IStock-No
D-POWER**MERCEDES****MB 100**

MB 100	2,4	43	4	02.89-	OM 615.970	11,0	Y-924J	7906	1
MB 100 D	2,4	56	4	02.89-	OM 616.963	11,5	Y-916J	5906	6

M-CLASS (163)

ML 400 CDI	163	4,0	184	8	09.00-06.05	OM 628.963	11,5	Y-745U	6346	11
------------	-----	-----	-----	---	-------------	------------	------	--------	------	----

M-CLASS (164)

ML 280 CDi	164	3,0	140	6	07.05-07.09	OM 642.940	4,4	Y8002AS	6287	51
ML 300 CDi	164	3,0	140	6	06.09-12.11	OM 642.940	4,4	Y8002AS	6287	51
ML 300 CDi	164	3,0	150	6	06.09-12.11	OM 642.820	7,0	CZ303	7865	54
ML 320 CDi	164	3,0	165	6	07.05-12.11	OM 642.820	7,0	CZ303	7865	54
ML 320 CDi	164	3,0	165	6	07.05-06.12	OM 642.940	4,4	Y8002AS	6287	51
ML 320 3.0 CDi	164	3,0	155	6	07.05-07.11	OM 642820	7,0	CZ303	7865	54
ML 350 CDi/CDi BlueTec	164	3,0	155	6	09.09-06.12	OM 642.820	7,0	CZ303	7865	54
ML 420 CDI	164	4,0	225	8	02.06-	OM 629.912	4,4	Y8002AS	6287	51
ML 450 CDI	164	4,0	225	8	06.09-	OM 629.912	4,4	Y8002AS	6287	51

M-CLASS (166)

ML 250 CDI (Euro 5)	166	2,2	150	4	06.11-	OM 651.960	7,0	CZ303	7865	54
ML 350 BlueTec (Engine No→41324858)	166	3,0	190	6	06.11-02.15	OM 642.826	7,0	CZ159	95398	84
ML 350 BlueTec (Engine No 41324859- →)	166	3,0	190	6	06.11-02.15	OM 642.826	7,0	CZ551	91584	85

R-CLASS (251)

R 280 CDi/CDi BlueEFFICIENCY	251	3,0	140	6	05.06-12.12	OM 642.870	7,0	CZ303	7865	54
R 280 CDi/CDi BlueEFFICIENCY	251	3,0	140	6	05.06-12.12	OM 642.950	4,4	Y8002AS	6287	51
R280/R300 3.0 CDi/CDi BlueEFFICIEN- CY (Country-version: USA)	251	3,0	140	6	05.06-12.12	OM 642870	7,0	CZ303	7865	54
R 300 CDi/CDi BlueEFFICIENCY (Engine No→41324858)	251	3,0	140	6	07.09-05.12	OM 642.872	7,0	CZ159	95398	84
R 300 CDi/CDi BlueEFFICIENCY	251	3,0	140	6	07.09-12.14	OM 642.870	7,0	CZ303	7865	54
R 300 CDi/CDi BlueEFFICIENCY	251	3,0	140	6	07.09-12.14	OM 642.872	7,0	CZ303	7865	54
R 300 CDi	251	3,0	140	6	07.09-12.12	OM 642.950	4,4	Y8002AS	6287	51
R 300 CDi/CDi BlueEFFICIENCY (15.8.2013→Production Date)	251	3,0	140	6	07.09-08.13	OM 642.950	4,4	Y8002AS	6287	51
R 300 CDi/CDi BlueEFFICIENCY (Pro- duction Date→ 15.8.2013)	251	3,0	140	6	08.13-12.14	OM 642.950	7,0	CZ303	7865	54
R280/R300 3.0 CDi/CDi BlueEFFICIEN- CY (Country-version: USA)	251	3,0	140	6	05.06-12.12	OM 642950	7,0	CZ303	7865	54
R 320 CDi/CDi BlueEFFICIENCY	251	3,0	165	6	01.06-12.14	OM 642.870	7,0	CZ303	7865	54
R 320 CDi/CDi BlueEFFICIENCY (15.8.2013→Production Date)	251	3,0	165	6	01.06-08.13	OM 642.950	4,4	Y8002AS	6287	51
R 320 CDi/CDi BlueEFFICIENCY (Pro- duction Date→ 15.8.2013)	251	3,0	165	6	08.13-12.14	OM 642.950	7,0	CZ303	7865	54
R320 3.0 CDi	251	3,0	155	6	01.06-12.12	OM 642870	7,0	CZ303	7865	54
R 350 BlueTec/CDi/CDi BlueTec	251	3,0	155	6	01.06-12.14	OM 642.870	7,0	CZ303	7865	54
R 350 Cdi (15.8.2013→Production Date)	251	3,0	165	6	07.09-08.13	OM 642.950	4,4	Y8002AS	6287	51
R 350 Cdi (Production Date→ 15.8.2013)	251	3,0	165	6	08.13-12.14	OM 642.950	7,0	CZ303	7865	54
R 350 CDi (Engine No→41324858)	251	3,0	195	6	01.10-05.12	OM 642.872	7,0	CZ159	95398	84
R 350 CDi	251	3,0	195	6	01.10-12.14	OM 642.872	7,0	CZ303	7865	54

S-CLASS (140)

S 300	140	3,0	130	6	05.96-10.98	OM 606.961	11,5	Y-925J	6848	16
S 300	140	3,0	130	6	05.96-10.98	OM 606.961	11,5	Y-930U	4275	30
S 350 TD	140	3,5	110	6	.93-		11,5	Y-916J	5906	6





e kW y i



Stock-No
D-POWER

MERCEDES

S-CLASS (220)

S 320 CDI	220	3.2	145	6	08.99-09.02	OM 613.960	11,5	Y-745U	6346	11
S 320 CDI	220	3.2	150	6	09.02-08.05	OM 648.960	11,5	Y-745U	6346	11
S 400 CDI	220	4.0	184	8	06.00-08.05	OM 628.960	11,5	Y-745U	6346	11
S 400 CDI	220	4.0	191	8	06.03-08.05	OM 628.960	11,5	Y-745U	6346	11

S-CLASS (221)

S 320 CDi	221	3.0	155	6	10.05-12.12	OM 642.930	4,4	Y8002AS	6287	51
S 320 CDi	221	3.0	173	6	06.06-12.12	OM 642.932	4,4	Y8002AS	6287	51
S 350 CDi/CDi BlueEFFICIENCY	221	3.0	173	6	06.09-07.13	OM 642.930	4,4	Y8002AS	6287	51
S 350 CDi/CDi BlueEFFICIENCY	221	3.0	173	6	06.09-07.13	OM 642.932	4,4	Y8002AS	6287	51
S 350 CDi BlueTec (Engine No->41324858)	221	3.0	190	6	06.10-05.12	OM 642.862	7,0	CZ159	95398	84
S 350 CDi BlueTec (Engine No->41324858)	221	3.0	190	6	06.10-05.12	OM 642.868	7,0	CZ159	95398	84
S 350 CDi BlueTec	221	3.0	190	6	06.10-07.13	OM 642.862	7,0	CZ303	7865	54
S 350 CDi BlueTec	221	3.0	190	6	06.10-07.13	OM 642.868	7,0	CZ303	7865	54
S 420 CDI	221	4.0	235	8	10.06-	OM 629.911	4,4	Y8002AS	6287	51

S-CLASS (222)

S 300 BlueTEC hybrid (Euro 5)	222	2.2	150	4	02.14-	OM 651.921	7,0	CZ303	7865	54
S 300 BlueTEC hybrid (Euro 6)	222	2.2	150	4	02.14-	OM 651.921	7,0	CZ551	91584	85
S 300 BlueTEC hybrid (Euro 5)	222	2.2	170	4	02.14-	OM 651.921	7,0	CZ303	7865	54
S 300 BlueTEC hybrid (Euro 6)	222	2.2	170	4	02.14-	OM 651.921	7,0	CZ551	91584	85
S 350 BlueTec	222	3.0	190	6	05.13-	OM 642.861	7,0	CZ303	7865	54
S 350 BlueTec	222	3.0	190	6	02.14-	OM 642.867	7,0	CZ303	7865	54

SLC (172)

SLC 250 2.2 CDi	172	2.2	150	4	01.16-10.17	OM 651980	7,0	CZ303	7865	54
-----------------	-----	-----	-----	---	-------------	-----------	-----	-------	------	----

SLK (172)

SLK 250 CDI	172	2.2	150	4	01.12-	OM 651.980	7,0	CZ303	7865	54
SLK 250 CDI Bluetec	172	2.2	150	4	01.12-	OM 651.980	7,0	CZ551	91584	85

SPRINTER 901/902

Sprinter 208 D	901, 902	2.3	58	4	04.95-	OM 601...	11,5	Y-916J	5906	6
Sprinter 212 D	901, 902	2.9	90	5	04.95-03.00	OM 602.980 10/50 & 20/60 DELA->9849	11,0	Y-924J	7906	1
Sprinter 212 D	901, 902	2.9	90	5	04.95-03.00	OM 602.980 12/52 & 22/62 DELA->136	11,0	Y-924J	7906	1
Sprinter 212 D	901, 902	2.9	90	5	04.95-03.00	OM 602.980 10/50 & 20/60 DELA 9850->	11,5	Y-929U	1749	41
Sprinter 212 D	901, 902	2.9	90	5	04.95-03.00	OM 602.980 12/52 & 22/62 DELA 137->	11,5	Y-929U	1749	41
Sprinter 308 D	901, 902	2.3	58	4	04.95- .00	OM 601.....	11,5	Y-916J	5906	6

SPRINTER 903

Sprinter 311 CDI	903	2.1	80	4	04.00-	OM 611.981	11,5	Y-745U	6346	11
Sprinter 312 D	903	2.9	90	5	04.95-03.00	OM 602.980 10/50 & 20/60 DELA->9849	11,0	Y-924J	7906	1
Sprinter 312 D	903	2.9	90	5	04.95-03.00	OM 602.980 12/52 & 22/62 DELA->136	11,0	Y-924J	7906	1
Sprinter 312 D	903	2.9	90	5	04.95-03.00	OM 602.980 10/50 & 20/60 DELA 9850->	11,5	Y-929U	1749	41
Sprinter 312 D	903	2.9	90	5	04.95-03.00	OM 602.980 12/52 & 22/62 DELA 137->	11,5	Y-929U	1749	41

SPRINTER 904

Sprinter 412 D	904	2.9	90	5	04.95-03.00	OM 602.980 10/50 & 20/60 DELA->9849	11,0	Y-924J	7906	1
Sprinter 412 D	904	2.9	90	5	04.95-03.00	OM 602.980 12/52 & 22/62 DELA->136	11,0	Y-924J	7906	1
Sprinter 412 D	904	2.9	90	5	04.95-03.00	OM 602.980 10/50 & 20/60 DELA 9850->	11,5	Y-929U	1749	41
Sprinter 412 D	904	2.9	90	5	04.95-03.00	OM 602.980 12/52 & 22/62 DELA 137->	11,5	Y-929U	1749	41





l kW C
Y I



Stock-No
D-POWER

MERCEDES

SPRINTER 906

Sprinter 209 CDI	906	2.2	65	4	06.06-	OM 646.984	11,5	Y-745U	6346	11
Sprinter 209 CDI	906	2.2	80	4	06.06-	OM 646.985	11,5	Y-745U	6346	11
Sprinter 210 CDI	906	2.2	70	4	03.09-	OM 651.955	7,0	CZ303	7865	54
Sprinter 213 CDI	906	2.2	95	4	03.09-	OM 651.956	7,0	CZ303	7865	54
Sprinter 216 CDI	906	2.2	120	4	03.09-	OM 651.957	7,0	CZ303	7865	54
Sprinter 218D Cdi Production Date 15.8.2013→	906	3.0	135	6	06.06-08.13	OM 642.992	4,4	Y8002AS	6287	51
Sprinter 218D Cdi Production Date →15.8.2013	906	3.0	135	6	08.13-	OM 642.992	7,0	CZ303	7865	54
Sprinter 219D BlueTec/BlueTec BlueEFFICIENCY/Cdi Production Date 15.8.2013→	906	3.0	140	6	03.09-08.13	OM 642.992	4,4	Y8002AS	6287	51
Sprinter 219D BlueTec/BlueTec BlueEFFICIENCY/Cdi Production Date →15.8.2013	906	3.0	140	6	08.13-	OM 642.992	7,0	CZ303	7865	54
Sprinter 310 CDI 906	906	2.2	70	4	03.09-	OM 651.955	7,0	CZ303	7865	54
Sprinter 313 CDI 906	906	2.2	95	4	06.06-	OM 651.956	7,0	CZ303	7865	54
Sprinter 313 CDI 906	906	2.2	95	4	08.11-	OM 651.955	7,0	CZ303	7865	54
Sprinter 316 CDI 906	906	2.2	120	4	03.09-	OM 651.957	7,0	CZ303	7865	54
Sprinter 318D Cdi (15.8.2013→Produc- tion Date)	906	3.0	135	6	06.06-08.13	OM 642.992	4,4	Y8002AS	6287	51
Sprinter 318D Cdi (Eng Nr.→41330714)	906	3.0	135	6	06.06-06.12	OM 642.896	4,4	Y8002AS	6287	51
Sprinter 318D Cdi (Eng Nr.→41330714)	906	3.0	135	6	02.08-06.12	OM 642.896	4,4	Y8002AS	6287	51
Sprinter 318D Cdi (41330714→ Eng Nr.)	906	3.0	135	6	06.12-	OM 642.896	7,0	CZ303	7865	54
Sprinter 318D Cdi (Production Date→ 15.8.2013)	906	3.0	135	6	08.13-	OM 642.992	7,0	CZ303	7865	54
Sprinter 318D Cdi (15.8.2013→Produc- tion Date)	906	3.0	140	6	03.09-08.13	OM 642.992	4,4	Y8002AS	6287	51
Sprinter 318D Cdi (Eng Nr.→41330714)	906	3.0	140	6	03.09-06.12	OM 642.898	4,4	Y8002AS	6287	51
Sprinter 318D Cdi (41330714→ Eng Nr.)	906	3.0	140	6	06.12-	OM 642.898	7,0	CZ303	7865	54
Sprinter 318D Cdi (Production Date→ 15.8.2013)	906	3.0	140	6	08.13-	OM 642.992	7,0	CZ303	7865	54
Sprinter 319D BlueTec/BlueTec BlueEF- FICIENCY/Cdi (Eng Nr.→41330714)	906	3.0	140	6	03.09-06.12	OM 642.898	4,4	Y8002AS	6287	51
Sprinter 319D BlueTec/Cdi (Eng Nr.→ 41330714)	906	3.0	140	6	03.09-06.12	OM 642.898	4,4	Y8002AS	6287	51
Sprinter 319D BlueTec/BlueTec BlueEF- FICIENCY/Cdi (41330714→ Eng Nr.)	906	3.0	140	6	06.12-	OM 642.898	7,0	CZ303	7865	54
Sprinter 319D BlueTec/Cdi (41330714→ Eng Nr.)	906	3.0	140	6	06.12-	OM 642.898	7,0	CZ303	7865	54
Sprinter 413 CDI 906	906	2.2	95	4	06.06-	OM 651.956	4,4	Y8002AS	6287	51
Sprinter 416 CDI 906	906	2.2	120	4	03.09-	OM 651.957	7,0	CZ303	7865	54
Sprinter 418D CDi	906	3.0	135	6	06.06-12.10	OM 642.896	4,4	Y8002AS	6287	51
Sprinter 418D CDi	906	3.0	135	6	06.06-12.10	OM 642.993	4,4	Y8002AS	6287	51
Sprinter 419D Cdi (15.8.2013→Produc- tion Date)	906	3.0	140	6	03.09-08.13	OM 642.992	4,4	Y8002AS	6287	51
Sprinter 419D Cdi (Eng Nr.→41330714)	906	3.0	140	6	03.09-06.12	OM 642.898	4,4	Y8002AS	6287	51
Sprinter 419D Cdi (41330714→ Eng Nr.)	906	3.0	140	6	06.12-	OM 642.898	7,0	CZ303	7865	54
Sprinter 419D Cdi (Production Date→ 15.8.2013)	906	3.0	140	6	08.13-	OM 642.992	7,0	CZ303	7865	54
Sprinter 510 CDI 906	906	2.2	70	4	03.09-	OM 651.955	7,0	CZ303	7865	54
Sprinter 513 CDI 906	906	2.2	95	4	03.09-	OM 651.956	7,0	CZ303	7865	54
Sprinter 516 CDI 906	906	2.2	120	4	03.09-	OM 651.957	7,0	CZ303	7865	54
Sprinter 518D Cdi (Eng Nr.→41330714)	906	3.0	135	6	06.06-06.12	OM 642.896	4,4	Y8002AS	6287	51
Sprinter 518D Cdi (41330714→ Eng Nr.)	906	3.0	135	6	06.12-	OM 642.896	7,0	CZ303	7865	54





e kW C
y i



Stock-No
D-POWER

MERCEDES

SPRINTER 906

Sprinter 519D BlueTec/BlueTec BlueEFFICIENCY/CDi (Eng Nr.→41330714)	906	3.0	140	6	03.09-06.12	OM 642.898	4,4	Y8002AS	6287	51
Sprinter 519D BlueTec/BlueTec BlueEFFICIENCY/CDi (41330714→ Eng Nr.)	906	3.0	140	6	06.12-	OM 642.898	7,0	CZ303	7865	54
Sprinter Series B906 2.2 CDi/CDi BlueEFFICIENCY	906	2.2	105	4	05.16-	OM 651.955	7,0	CZ303	7865	54
Sprinter Series B906 2.2 BlueTec/BlueTec BlueEFFICIENCY/CDi/CDi BlueEFFICIENCY	906	2.2	120	4	08.11-	OM 651.955	7,0	CZ303	7865	54
Sprinter Series B906 2.2 BlueTec/BlueTec BlueEFFICIENCY/CDi/CDi BlueEFFICIENCY	906	2.2	120	4	08.11-	OM 651.957	7,0	CZ303	7865	54
Sprinter 311D/211D/511D/411D 2.2 CDi/CDi BlueEFFICIENCY	906	2.2	84	4	04.16-	OM 651.955	7,0	CZ303	7865	54
Sprinter 313D/213D/513D 2.2 BlueTec/BlueTec BlueEFFICIENCY/CDi/CDi BlueEFFICIENCY	906	2.2	95	4	03.09-	OM 651.955	7,0	CZ303	7865	54
Sprinter Series B906 2.2 BlueTec/BlueTec BlueEFFICIENCY/CDi/CDi BlueEFFICIENCY	906	2.2	95	4	03.09-	OM 651.956	7,0	CZ303	7865	54
Sprinter Series B906 2.2 BlueTec/BlueTec BlueEFFICIENCY/CDi/CDi BlueEFFICIENCY	906	2.2	95	4	03.09-	OM 651.957	7,0	CZ303	7865	54
Sprinter 318D/518D/218D 3.0 CDi (Engine No 41330714→)	906	3.0	135	6	06.12-	OM 642.896	7,0	CZ303	7865	54
Sprinter 318D/518D 3.0 CDi (Engine No 41330714→)	906	3.0	135	6	06.12-	OM 642.896	7,0	CZ303	7865	54
Sprinter 318D/518D/218D 3.0 CDi (Engine No 41330714→)	906	3.0	135	6	06.12-	OM 642.992	7,0	CZ303	7865	54
Sprinter 318D/518D/218D 3.0 CDi (Engine No 41330714→)	906	3.0	135	6	06.12-	OM 642.993	7,0	CZ303	7865	54
Sprinter 319D/519D/419D 3.0 BlueTec/BlueTec BlueEFFICIENCY/CDi (Engine No 41330714→)	906	3.0	140	6	07.12-	OM 642.896	7,0	CZ303	7865	54
Sprinter 319D 3.0 BlueTec/BlueTec BlueEFFICIENCY/CDi (Engine No 41330714→)	906	3.0	140	6	07.12-	OM 642.898	7,0	CZ303	7865	54
Sprinter 319D/519D/419D 3.0 BlueTec/BlueTec BlueEFFICIENCY/CDi (Engine No 41330714→)	906	3.0	140	6	07.12-	OM 642.896	7,0	CZ303	7865	54
Sprinter 319D/519D/419D 3.0 BlueTec/BlueTec BlueEFFICIENCY/CDi (Engine No 41330714→)	906	3.0	140	6	07.12-	OM 642.992	7,0	CZ303	7865	54

SPRINTER 907/910

Sprinter 314D/214D 2.2 CDi	910	2.2	105	4	02.18-	OM 651.950	7,0	CZ303	7865	54
Sprinter 311D 2.2 CDi	910	2.2	84	4	02.18-	OM 651.950	7,0	CZ303	7865	54
Sprinter 211D 2.2 Cdi	910	2.2	84	4	02.18-	OM 651.950	7,0	CZ303	7865	54
Sprinter 411D 2.2 CDi	910	2.2	84	4	02.18-	OM 651.950	7,0	CZ303	7865	54
Sprinter 319D/419D/519D 3.0 CDi	907	3.0	140	6	02.18-	OM 642.899	7,0	CZ303	7865	54

UNIMOG

Unimog 100 L		2.9	71	5	11.92-	OM 602.948	11,5	Y-916J	5906	6
Unimog 600/650		2.4	38	4	01.88-	OM 616..	11,0	Y-924J	7906	1
Unimog U 90		3.0	65	5	11.92-	OM 602.941	11,5	Y-916J	5906	6

VANEO (414)

Vaneo CDI	414	1.7	55	4	01.02-	OM 668.914	11,5	Y-746J	3078	38
Vaneo CDI	414	1.7	67	4	01.02-	OM 668.914	11,5	Y-746J	3078	38

V-CLASS (447)

V 200 CDI	447	2.2	100	4	03.14-	OM 651.950	7,0	CZ551	91584	85
V 200 2.2 CDi/CDi BlueEFFICIENCY	447	2.2	100	4	03.14-	OM 651.950	7,0	CZ303	7865	54
V 220 CDI	447	2.2	120	4	03.14-	OM 651.950	7,0	CZ551	91584	85





kw
C
y
i



Stock-No
D-POWER

MERCEDES

V-CLASS (447)

V 250 BlueTEC	447	2,2	150	4	03.14-	OM 651.950	7,0	CZ551	91584	85
---------------	-----	-----	-----	---	--------	------------	-----	-------	-------	----

V-CLASS (638)

V 200 CDI	638	2,2	75	4	03.99-07.03	OM 611.980	11,5	Y-745U	6346	11
V 220 CDI	638	2,2	90	4	03.99-07.03	OM 611.980	11,5	Y-745U	6346	11
V 230 TD	638	2,3	72	4	09.96-	OM 601.970	11,5	Y-916J	5906	6

VIANO (639)

Viano 2.0l CDI	639	2,2	80	4	07.03-	OM 646.982	11,5	Y-745U	6346	11
Viano 2.2l CDI	639	2,2	100	4	07.10-	OM 651.940	7,0	CZ303	7865	54
Viano 2.2l CDI	639	2,2	110	4	09.03-	OM 646.983	11,5	Y-745U	6346	11
Viano 2.2l CDI	639	2,2	120	4	07.10-	OM 651.940	7,0	CZ303	7865	54
Viano CDi/CDi BlueEFFICIENCY (For OE-No. A0011595701 / A0011596601)	639	3,0	150	6	03.06-	OM 642.990	7,0	CZ303	7865	54
Viano CDi/CDi BlueEFFICIENCY (For OE-No. A0011595001)	639	3,0	150	6	03.06-	OM 642.990	4,4	Y8002AS	6287	51
Viano CDi/CDi BlueEFFICIENCY	639	3,0	165	6	07.10-	OM 642.890	7,0	CZ303	7865	54

VITO (447)

Vito 109 BlueTec CDI	447	1,6	65	4	09.14-	OM 622.951	4,5	Y1010AS	97618	88
Vito 114 CDI	447	2,2	100	4	09.14-	OM 651.950	7,0	CZ551	91584	85
Vito 116 CDI	447	2,2	120	4	09.14-	OM 651.950	7,0	CZ551	91584	85
Vito 119 BlueTEC	447	2,2	140	4	09.14-	OM 651.950	7,0	CZ551	91584	85
Vito 160 CDI	447	1,6	65	4	09.14-	OM 622.951	4,5	Y1010AS	97618	88
Vito 180 CDI	447	1,6	84	4	09.14-	OM 622.951	4,5	Y1010AS	97618	88

VITO (638)

Vito 108 D	638	2,3	60	4	02.96-	OM 601.942	11,5	Y-916J	5906	6
Vito 110 D	638	2,3	72	4	02.96-	OM 601.970	11,5	Y-916J	5906	6

VITO (639)

Vito 110 CDI	639	2,2	70	4	09.10-	OM 651.940	7,0	CZ303	7865	54
Vito 113 CDI	639	2,2	100	4	07.10-	OM 651.940	7,0	CZ303	7865	54
Vito 116 CDI	639	2,2	120	4	09.10-	OM 651.940	7,0	CZ303	7865	54
Vito 116/113 2.2 CDi/CDi BlueEFFICIENCY	639	2,2	120	4	09.10-08.14	OM 651.940	7,0	CZ303	7865	54
Vito 120 Cdi (15.8.2013→Production Date)	639	3,0	150	6	03.06-08.13	OM 642.990	4,4	Y8002AS	6287	51
Vito 120 Cdi (Production Date→15.8.2013)	639	3,0	150	6	08.13-08.14	OM 642.990	7,0	CZ303	7865	54
Vito 122 CDi/CDi BlueEFFICIENCY	639	3,0	165	6	09.10-08.14	OM 642.890	7,0	CZ303	7865	54

MINI

MINI CLUBMAN COOPER

Mini Clubman Cooper D	R55	1,6	80	4	10.07-	9HZ (DV6TED4)	11,0	YE05	91322	73
Mini Clubman Cooper D	R55	1,6	82	4	03.10-	N47 C16A	4,4	Y1039AS	91648	80
Mini Clubman Cooper D	R55	2,0	82	4	02.11-	N47 C20A	4,4	Y1039AS	91648	80
Mini Clubman Cooper SD	R55	2,0	100	4	02.11-	N47 C20A	4,4	Y1039AS	91648	80
Mini Clubman Cooper SD	R55	2,0	105	4	02.11-	N47 C20A	4,4	Y1039AS	91648	80

MINI CLUBMAN ONE

Mini Clubman One D	R55	1,6	66	4	03.10-	N47 C16A	4,4	Y1039AS	91648	80
--------------------	-----	-----	----	---	--------	----------	-----	---------	-------	----

MINI COOPER

Mini Cooper D	R56	1,6	80	4	03.07-09.10	W16 D16	11,0	YE05	91322	73
Mini Cooper D	R56	1,6	82	4	06.10-	N47 D16, N47 C16A	4,4	Y1039AS	91648	80





e kW C
y
i



Stock-No
D-POWER™

MINI

MINI COOPER

Mini Cooper D	R56	2.0	82	4	02.11-	N47 C20A	4,4	Y1039AS	91648	80
Mini Cooper SD	R56	2.0	100	4	02.11-	N47 C20A	4,4	Y1039AS	91648	80
Mini Cooper SD	R56	2.0	105	4	02.11-	N47 C20A	4,4	Y1039AS	91648	80

MINI COUNTRYMAN

Mini Countryman One D	R60	1.6	66	4	06.10-	N47 C16A	4,4	Y1039AS	91648	80
Mini Countryman Cooper D	R60	1.6	82	4	06.10-	N47 C16A	4,4	Y1039AS	91648	80
Mini Countryman Cooper D	R60	2.0	82	4	02.11-	N47 C20A	4,4	Y1039AS	91648	80
Mini Countryman Cooper SD ALL4	R60	2.0	100	4	02.11-	N47 C20A	4,4	Y1039AS	91648	80
Mini Countryman Cooper SD	R60	2.0	105	4	02.11-	N47 C20A	4,4	Y1039AS	91648	80

MINI COUPE

Mini Coupe Cooper SD	R58	2.0	100	4	09.11-	N47 C20A	4,4	Y1039AS	91648	80
Mini Coupe Cooper SD	R58	2.0	105	4	09.11-	N47 C20A	4,4	Y1039AS	91648	80

MINI D

Mini D	R50	1.4	55	4	03.03-	W17 D14	11,0	Y-542J	5513	45
Mini D	R50	1.4	65	4	03.03-	W17 D14	11,0	Y-542J	5513	45

MINI ONE

Mini One D	R56	1.6	66	4	06.09-07.10	9HZ (DV6TED4)	11,0	YE05	91322	73
Mini One D	R56	1.6	66	4	07.10-	N47 D16, N47 C16A	4,4	Y1039AS	91648	80

MINI PACEMAN

Mini Paceman Cooper D	R61	1.6	82	4	09.12-	N47 C16A	4,4	Y1039AS	91648	80
Mini Paceman Cooper SD	R61	2.0	105	4	10.12-	N47 C20A	4,4	Y1039AS	91648	80

MINI ROADSTER

Mini Roadster Cooper SD	R59	2.0	100	4	02.12-	N47 C20A	4,4	Y1039AS	91648	80
Mini Roadster Cooper SD	R59	2.0	105	4	02.12-	N47 C20A	4,4	Y1039AS	91648	80

MITSUBISHI

ASX

ASX 1.8 DiD	GA6W	1.8	85	4	06.10-	4N13	11,0	CZ267	90900	90
ASX 1.8 DiD	GA6W	1.8	110	4	04.10-	4N13	11,0	CZ267	90900	90
ASX Van 1.8 DiD	GA6W	1.8	110	4	06.10-	4N13	11,0	CZ267	90900	90
ASX 2.2 DiD	GA8W	2.2	110	4	04.13-	4N14	11,0	CZ267	90900	90

CANTER

Canter FB35		2.5	55	4	09.92-09.96	4D56	11,0	CZ257	97284	83
Canter		3.0	92		09.01-02.05	4M42-0AT	11,0	Y1007J	3040	59
Canter	NFE301, NFE311, NFE321, NFE331			4	10.85-10.03	4D30	23,0	Y-971M	5035	
Canter	NFE401			4	10.85-10.03	4D30	23,0	Y-971M	5035	

CARISMA

Carisma TD		1.9	66	4	10.96-	F8Q	11,0	Y-933J	7947	25
Carisma 1.9 DI-D	DA_	1.9	75	4	09.00-	F9Q1	12,0	Y-732J	5605	4
Carisma 1.9 DI-D	DA_	1.9	85	4	09.00-	F9Q1, F9Q2	12,0	Y-732J	5605	4

CHALLENGER

Challenger		2.5		4	11.98-		11,0	Y-733J	6592	13
------------	--	-----	--	---	--------	--	------	--------	------	----

CHARIOT

Chariot TD		2.0	60	4	01.92-12.97	4D68T	11,0	CZ257	97284	83
------------	--	-----	----	---	-------------	-------	------	-------	-------	----



e kW C
Y IStock-No
D-POWER™**MITSUBISHI****COLT 6**

Colt DID Z38A	1.5	50	3	04.05-09.08	639 938	11,5	YE13	8643	
Colt DID Z39A	1.5	70	3	04.05-09.08	639 939	11,5	YE13	8643	

GALANT

Galant TD	2.5	89	4	11.92-09.96	4D68T	11,0	CZ257	97284	83
Galant Estate/Wagon TD	2.5	89	4	10.96-07.01	4D68T	11,0	CZ257	97284	83
Galant TD	2.5	89	4	10.96-07.01	4D68T	11,0	CZ257	97284	83

GALANT / SIGMA

Galant / Sigma			4	.80-	4D55	12,0	Y-115T1	2189	
----------------	--	--	---	------	------	------	---------	------	--

GALANT / SIGMA QGS TYP

Galant / Sigma QGS Typ			4	.80-	4D55T	6,0	Y-115R1	2161	
------------------------	--	--	---	------	-------	-----	---------	------	--

GALANT STATION WAGON QGS TYP

Galant Station Wagon QGS Typ			4	.83-	4D55	6,0	Y-115R1	2161	
------------------------------	--	--	---	------	------	-----	---------	------	--

GALLOPER

Galloper Td	2.5	65	4	02.99- .01	D4BH	11,0	CZ257	97284	83
Galloper Td	2.5	73	4	02.99- .01	D4BH	11,0	CZ257	97284	83

GRANDIS

Grandis 2.0 DI-D (without soot filter)	2.0	100	4	09.05-03.10	BSY (VW engine)	4,4	YE14	7768	48
Grandis 2.0 DI-D (with soot filter)	2.0	100	4	06.07-03.10	BSY (VW engine)	7,0	CZ304	9864	55
Grandis 2.0 DI-D (without soot filter)	2.0	103	4	02.07-03.10	BWC	4,4	YE14	7768	48
Grandis 2.0 DI-D (with soot filter)	2.0	103	4	06.07-03.10	BWC	7,0	CZ304	9864	55

L200

L200 2.4 Mivec	KK1T, KK2T	2.4	113	4	08.15-	4N15	11,0	CZ267	90900	90
L200 2.4 Mivec	KL1T, KL2T	2.4	133	4	09.15-	4N15	11,0	CZ267	90900	90
L200	K0_T, K1_T, K2_T, K3_T	2.5	51	4	06.94-08.96	4D56 SOHC	11,0	CZ257	97284	83
L200 2.5 (For OE-No. 1820A020; EURO 4)	KB4T	2.5	55	4	08.11-12.15	4D56	11,0	CZ271	94248	
L200 2.5 (For OE-No. 1820A020)	KA4T	2.5	66	4	08.11-12.15	4D56TD	11,0	CZ271	94248	
L200 2.5 DiD (For OE-No. 1820A020; EURO 5)	KA4T	2.5	94	4	08.07-12.15	4D56HP, 4D56 (16V)	11,0	CZ271	94248	
L200 2.5 TDiC (For OE-No. 1820A020; EURO 4)	KB4T	2.5	98	4	11.05-12.15	4D56 (16V)	11,0	CZ271	94248	
L200 2.5 DiD (For OE-No. 1820A020; EURO 5)	KA4T	2.5	123	4	08.11-12.15	4D56HP	11,0	CZ271	94248	
L200 2.5 DiD (For OE-No. 1820A020)	KA4T	2.5	131	4	03.13-12.15	4D56HP	11,0	CZ271	94248	
L200		2.5		4	09.96-03.05	4D56	11,0	CZ257	97284	83
L200 TDiC		2.5		4	09.96-12.07	4D56	11,0	CZ257	97284	83
L200		2.5		4	- .93	4D55	12,0	Y-115T1	2189	

L200 KB4T

L200 2.5 DI-D	KB4T	2.5	94	4	04.10-	4D56HP	11,0	CZ251	91238	76
L200 2.5 DI-D	KB4T	2.5	100	4	11.05-	4D56HP	11,0	CZ251	91238	76
L200 2.5 DI-D (Euro 3 / Euro 4)	KB4T	2.5	123	4	08.07-	4D56HP	11,0	CZ251	91238	76
L200 2.5 DI-D	KB4T	2.5	131	4	06.09-	4D56HP	11,0	CZ251	91238	76

L300

L300 TD	P	2.5	64	4	06.93- .96	4D56 SOHC	11,0	CZ257	97284	83
L300		2.5		4	.97-	4D56	11,0	Y-733J	6592	13
L300		2.5		4	- .92	4D5	12,0	Y-115T1	2189	

L300 / 4WD

L300 / 4WD		2.3		4	04.83-	4D55	12,0	Y-115T1	2189	
------------	--	-----	--	---	--------	------	------	---------	------	--





e kW C
y i



Stock-No
D-POWER™

MITSUBISHI

L400

L400 TD	2.5	64	4	12.94-03.03	4D56	11,0	CZ257	97284	83
L400 TD	2.5	64	4	12.94-03.03	4D56T	11,0	CZ257	97284	83
L400 TDiC	2.5	73	4	05.95-05.00	4D56	11,0	CZ257	97284	83

LANCER

Lancer 1.8 DiD	CY9A	1.8	85	4	07.10-	4N13	11,0	CZ267	90900	90
Lancer Sportback 1.8 DiD	CX9A	1.8	85	4	07.10-	4N13	11,0	CZ267	90900	90
Lancer 1.8 DiD	CY9A	1.8	110	4	07.10-	4N13	11,0	CZ267	90900	90
Lancer Sportback 1.8 DiD	CX9A	1.8	110	4	07.10-	4N13	11,0	CZ267	90900	90
Lancer Estate/Wagon		2.0	50	4	06.92-08.03	4D68	11,0	CZ257	97284	83
Lancer		2.0	50	4	08.93-08.95	4D68	11,0	CZ257	97284	83
Lancer Estate/Wagon TD		2.0	65	4	06.95-08.03	4D68T	11,0	CZ257	97284	83

MONTERO

Montero TD		2.5	73	4	03.91-04.00	4D56	11,0	CZ257	97284	83
Montero				4	.83-	4D55 QGS Type	6,0	Y-115R1	2161	
Montero				4	.83-	4D55	12,0	Y-115T1	2189	
Montero Sport				4	.97-		11,0	Y-733J	6592	13

MULTICAR M25

Multicar M25			40	4	01.91-	VW028B-1Y	12,0	Y-918J	6285	2
--------------	--	--	----	---	--------	-----------	------	--------	------	---

MULTICAR M26

Multicar M26			40	4	01.91-	VW028B-1Y	12,0	Y-918J	6285	2
--------------	--	--	----	---	--------	-----------	------	--------	------	---

OUTLANDER II

Outlander II 2.0 Di-D	CW8W	2.0	103	4	11.06-06.10	BSY	4,4	YE14	7768	48
Outlander 2.2 DiD	CW1W	2.2	103	4	09.10-12.12	4N14	11,0	CZ267	90900	90
Outlander II 2.2 Di-D	CW7W	2.2	115	4	08.07-12.12	4HK, 4HN	11,0	YE08	4966	
Outlander 2.2 DiD	CW1W	2.2	130	4	11.06-12.12	4N14	11,0	CZ267	90900	90
Outlander Van 2.2 DiD	CW1W	2.2	130	4	09.10-12.12	4N14	11,0	CZ267	90900	90

OUTLANDER III

Outlander 2.2 DiD	GF6W	2.2	110	4	08.12-	4N14	11,0	CZ267	90900	90
Outlander Van 2.2 DiD	GF6W	2.2	110	4	04.13-	4N14	11,0	CZ267	90900	90

PAJERO

Pajero TD not QGS Type		2.5	62		06.86-	4D56 Turbo not QGS Type	12,0	Y-115T1	2189	
Pajero TDiC		2.5	73	4	12.90-10.99	4D56	11,0	CZ257	97284	83
Pajero	V46W, V26W	2.8	92	4	06.94-04.00	4M40-T	11,0	CZ256	90066	
Pajero 3.2 Di-D		3.2	118	4	04.00-		11,0	Y-532J	7782	
Pajero 3.2 Di-D	V88W, V98W	3.2	118	4	02.07-	4M41	11,0	CZ251	91238	76
Pajero 3.2 Di-D	V88W, V98W	3.2	125	4	02.07-	4M41	11,0	CZ251	91238	76
Pajero 3.2 Di-D	V88W, V98W	3.2	147	4	01.09-	4M41	11,0	CZ251	91238	76

PAJERO CLASSIC

Pajero Classic		3.2	118		05.05-	4M41	11,0	Y1007J	3040	59
----------------	--	-----	-----	--	--------	------	------	--------	------	----

PAJERO III

Pajero III		3.2	118		10.01-	4M41	11,0	Y1007J	3040	59
Pajero III		3.2	121		04.00-10.01	4M41	11,0	Y1007J	3040	59

SHOGUN

Shogun TDiC		2.5	73	4	03.91-04.00	4D56	11,0	CZ257	97284	83
-------------	--	-----	----	---	-------------	------	------	-------	-------	----





e kW C
Y
I



Stock-No
D-POWER

mitsubishi

SPACE GEAR

Space Gear TD	2,5	64	4	05.95-05.00	4D56T	11,0	CZ257	97284	83
Space Gear TDiC	2,5	73	4	05.95-05.00	4D56	11,0	CZ257	97284	83
Space Gear TDiC	2,5	73	4	05.95-05.00	4D56TD	11,0	CZ257	97284	83

SPACE RUNNER

Space Runner TD	2,0	60	4	06.91-09.99	4D68T	11,0	CZ257	97284	83
-----------------	-----	----	---	-------------	-------	------	-------	-------	----

SPACE STAR

Space Star 1.9 DI-D	DA_	1,9	75	4	08.00-12.04	F9Q1	12,0	Y-732J	5605	4
Space Star 1.9 DI-D	DG_A	1,9	85	4	08.02-12.04	F9Q2	12,0	Y-732J	5605	4

SPACE WAGON

Space Wagon TD	2,0	60	4	10.92-10.98	4D68T	11,0	CZ257	97284	83
----------------	-----	----	---	-------------	-------	------	-------	-------	----

STRAKER

Straker	2,5	55	4	09.96-07.01	4D56	11,0	CZ257	97284	83
---------	-----	----	---	-------------	------	------	-------	-------	----

TRUCK

Truck / 4WD				.83-	4D55T	6,0	Y-115R1	2161	
-------------	--	--	--	------	-------	-----	---------	------	--

NISSAN

ALMERA N15

Almera 2.0 Hatchback	N15	2,0	55	4	07.95- .00	CD20E	11,0	CZ260	91904	
Almera Di 2.2	N15	2,2	82	4	02.00- .03	YD22DDT	11,0	Y-519J	93293	61

ALMERA N16

Almera dCi 1.5	N16	1,5	60	4	01.03-	K9K	12,0	Y-732J	5605	4
Almera 2.2	N16, ATV10	2,2	82	4	09.03-	YD22DDTi	11,0	Y-519J	93293	61
Almera 2.2	N16, ATV10	2,2	100	4	09.03-	YD22DDTi	11,0	Y-519J	93293	61

ALMERA TINO

Almera Tino 2.2 VDI		2,2	84	4	04.02-	YD22ET	11,0	Y-519J	93293	61
---------------------	--	-----	----	---	--------	--------	------	--------	-------	----

ALMERA TINO N16

Almera Tino N16/ATV10		2,2	82	4	09.03-	YD22DDTi	11,0	Y-519J	93293	61
Almera Tino N16/ATV10		2,2	100	4	09.03-	YD22DDTi	11,0	Y-519J	93293	61

CABSTAR

Cabstar 3.0 TDi	F24M	3,0	110	4	10.06-	ZD30DDTi	11,0	Y-538J	93079	
-----------------	------	-----	-----	---	--------	----------	------	--------	-------	--

CUBE

Cube 1.5 dCi	Z12	1,5	78	4	03.10-	K9K	4,4	Y1035AS	94103	77
Cube 1.5 dCi	Z12	1,5	81	4	03.10-	K9K	4,4	Y1035AS	94103	77

D21

D21		2,5			.93-	TD25	11,0	Y-707RS	4937	
D21		2,7			.93-	TD27	11,0	Y-707RS	4937	
D21		2,7			.93-	TD27T	11,0	Y-712RS	6140	

EVALIA

Evalia 1.5 dCi	M20M	1,5	66	4	04.11-	K9K	4,4	Y1035AS	94103	77
Evalia 1.5 dCi	M20M	1,5	81	4	04.11-	K9K	4,4	Y1035AS	94103	77

INTERSTAR

Interstar dCi 80		1,9	60	4	07.02-	F9Q772	12,0	Y-732J	5605	4
Interstar dCi 90		2,2	66	4	07.02-	G9T722	11,0	Y-517J	91766	66
Interstar dCi 100		2,5	74	4	04.06-	G9U754	11,0	Y-517J	91766	66
Interstar dCi 115		2,5	84	4	04.02-	G9U720	11,0	Y-517J	91766	66
Interstar dCi 120		2,5	88	4	09.06-	G9U650	11,0	Y-517J	91766	66





l kW C
y
i



Stock-No
D-POWER™

NISSAN

INTERSTAR

Interstar dCi 150		2.5	107	4	09.06-	G9U632		11,0	Y-517J	91766	66
-------------------	--	-----	-----	---	--------	--------	--	------	--------	-------	----

JUKE

Juke 1.5 dCi	F15E	1.5	81	4	06.10-	K9K		4,4	Y1035AS	94103	77
--------------	------	-----	----	---	--------	-----	--	-----	---------	-------	----

KUBISTAR

Kubistar Cdi		1.5	48	4	08.03-	K9K		12,0	Y-732J	5605	4
--------------	--	-----	----	---	--------	-----	--	------	--------	------	---

Kubistar Cdi		1.5	60	4	08.03-	K9K		12,0	Y-732J	5605	4
--------------	--	-----	----	---	--------	-----	--	------	--------	------	---

MICRA II

Micra II 1.5 D	K11	1.5	42	4	.98- .00	VJX		11,0	Y-503J	1009	10
----------------	-----	-----	----	---	----------	-----	--	------	--------	------	----

Micra II 1.5 D	K11	1.5	42	4	.98- .00	VJZ		11,0	Y-503J	1009	10
----------------	-----	-----	----	---	----------	-----	--	------	--------	------	----

MICRA III

Micra III 1.5 dCi	K12	1.5	48	4	04.03-	K9K		12,0	Y-732J	5605	4
-------------------	-----	-----	----	---	--------	-----	--	------	--------	------	---

Micra III 1.5 dCi	K12	1.5	60	4	09.03-	K9K		12,0	Y-732J	5605	4
-------------------	-----	-----	----	---	--------	-----	--	------	--------	------	---

NAVARA

Navara 3.0 dCi	D40M	3.0	170	6	02.10-	V9X		7,0	CZ167	90646	91
----------------	------	-----	-----	---	--------	-----	--	-----	-------	-------	----

NOTE I

Note I 1.5 dCi	E11	1.5	50	4	03.06-09.12	K9K 700		12,0	Y-732J	5605	4
----------------	-----	-----	----	---	-------------	---------	--	------	--------	------	---

Note I 1.5 dCi	E11	1.5	63	4	03.06-09.12	K9K		12,0	Y-732J	5605	4
----------------	-----	-----	----	---	-------------	-----	--	------	--------	------	---

Note I 1.5 dCi	E11	1.5	66	4	09.10-08.13	K9K 276		4,4	Y1035AS	94103	77
----------------	-----	-----	----	---	-------------	---------	--	-----	---------	-------	----

Note I 1.5 dCi	E11	1.5	76	4	07.08-12.10	K9K278, K9K292		12,0	Y-732J	5605	4
----------------	-----	-----	----	---	-------------	----------------	--	------	--------	------	---

NOTE II

Note II 1.5 dCi	E12	1.5	66	4	06.13-	K9K		4,4	Y1035AS	94103	77
-----------------	-----	-----	----	---	--------	-----	--	-----	---------	-------	----

NP300

NP300 2.3 dCi	D23M	2.3	120	4	11.15-	YS23DDT		4,5	Y1047AS	95340	
---------------	------	-----	-----	---	--------	---------	--	-----	---------	-------	--

NP300 2.3 dCi	D23M	2.3	140	4	11.15-	YS23DDTT		4,5	Y1047AS	95340	
---------------	------	-----	-----	---	--------	----------	--	-----	---------	-------	--

NV200

NV200 1.5 dCi	M20M	1.5	66	4	04.11-	K9K		4,4	Y1035AS	94103	77
---------------	------	-----	----	---	--------	-----	--	-----	---------	-------	----

NV200 1.5 dCi	M20M	1.5	81	4	04.11-	K9K		4,4	Y1035AS	94103	77
---------------	------	-----	----	---	--------	-----	--	-----	---------	-------	----

NV300

NV300 1.6 dCi 95	X82	1.6	70	4	09.16-	R9M413		4,5	Y1010AS	91210	88
------------------	-----	-----	----	---	--------	--------	--	-----	---------	-------	----

NV300 1.6 dCi 95	X82	1.6	70	4	09.16-	R9M415		4,5	Y1010AS	91210	88
------------------	-----	-----	----	---	--------	--------	--	-----	---------	-------	----

NV300 1.6 dCi 120	X82	1.6	89	4	09.16-	R9M413		4,5	Y1010AS	91210	88
-------------------	-----	-----	----	---	--------	--------	--	-----	---------	-------	----

NV300 1.6 dCi 125	X82	1.6	92	4	09.16-	R9M452		4,5	Y1010AS	91210	88
-------------------	-----	-----	----	---	--------	--------	--	-----	---------	-------	----

NV300 1.6 dCi 145	X82	1.6	107	4	09.16-	R9M452		4,5	Y1010AS	91210	88
-------------------	-----	-----	-----	---	--------	--------	--	-----	---------	-------	----

NV400

NV400 2.3 dCi 110	X62, X62B	2.3	81	4	06.14-	M9T704		4,5	Y1047AS	95340	
-------------------	-----------	-----	----	---	--------	--------	--	-----	---------	-------	--

NV400 2.3 dCi 110	X62, X62B	2.3	81	4	06.14-	M9T870		4,5	Y1047AS	95340	
-------------------	-----------	-----	----	---	--------	--------	--	-----	---------	-------	--

NV400 2.3 dCi 130	X62B	2.3	96	4	09.16-	M9T704		4,5	Y1047AS	95340	
-------------------	------	-----	----	---	--------	--------	--	-----	---------	-------	--

NV400 2.3 dCi 130	X62B	2.3	96	4	09.16-	M9T710		4,5	Y1047AS	95340	
-------------------	------	-----	----	---	--------	--------	--	-----	---------	-------	--

NV400 2.3 dCi	X62	2.3	100	4	06.14-	M9T702		4,5	Y1047AS	95340	
---------------	-----	-----	-----	---	--------	--------	--	-----	---------	-------	--

NV400 2.3 dCi	X62, X62B	2.3	110	4	02.14-	M9T880		4,5	Y1047AS	95340	
---------------	-----------	-----	-----	---	--------	--------	--	-----	---------	-------	--

NV400 2.3 dCi	X62, X62B	2.3	110	4	02.14-	M9T716		4,5	Y1047AS	95340	
---------------	-----------	-----	-----	---	--------	--------	--	-----	---------	-------	--

NV400 2.3 dCi 165	X62	2.3	120	4	06.14-	M9T702		4,5	Y1047AS	95340	
-------------------	-----	-----	-----	---	--------	--------	--	-----	---------	-------	--

NV400 2.3 dCi 170	X62B	2.3	125	4	09.16-	M9T706		4,5	Y1047AS	95340	
-------------------	------	-----	-----	---	--------	--------	--	-----	---------	-------	--

PATHFINDER D21

Pathfinder D21		2.5		4	.93-	TD25		11,0	Y-707RS	4937	
----------------	--	-----	--	---	------	------	--	------	---------	------	--





kW
Cyl
I



Stock-No
D-POWER

NISSAN

PATHFINDER D21

Pathfinder D21	2.7		4	.93-	TD27	11,0	Y-707RS	4937	
Pathfinder D21	2.7		4	.93-	TD27T	11,0	Y-712RS	6140	

PATHFINDER R51M

Pathfinder 3.0 dCi	R51M	3.0	170	6	08.10-08.14	V9X	7,0	CZ167	90646	91
--------------------	-------------	-----	-----	---	-------------	-----	-----	-------	-------	----

PATROL

Patrol	2.7		6	02.93-	TD27	11,0	Y-707RS	4937		
Patrol Y61 (Cyl. 1,2,3 CZ166; Cyl. 4,5,6 CX51)	2.8	95	6	04.98-	RD28 (only if NGK is OE)	6,5 + 6,5	CX51+ CZ166	2896 + 93633		
Patrol 3.0 Di Y61	3.0	116	4	05.00- .06	ZD30DDTi (only if NGK is OE)	11,0	CZ258	95173		
Patrol 3.0 Di Y61	3.0	116	4	11.05-03.10	ZD30DDTi (only if NGK is OE)	11,0	Y-538J	93079		
Patrol GR 3.0 TDi	Y61	3.0	118	4	11.05-03.10	ZD30DDTi	11,0	Y-538J	93079	
Patrol	3.3		6	11.84-	SD33 12V	11,0	Y-705RS	1249		
Patrol	3.3		6	11.84-	SD33T 12V	11,0	Y-705RS	1249		
Patrol	3.3		6	11.84-	SD33 24V	24,0	Y-755RS	7771		
Patrol	3.3		6	11.84-	SD33T 24V	24,0	Y-755RS	7771		
Patrol 160	4.2		6	-12.98	TD42 12V	11,0	Y-707RS	4937		
Patrol 160	4.2		6	-12.98	TD42 24V	24,0	Y-757RS	4018		

PICK UP

Pick-Up 720	2.3		4	.87-	SD23	11,0	Y-705RS	1249	
Pick Up	2.5	98	4	12.01-	YD25DDTi	11,0	Y-519J	93293	61
Pick-Up 720	2.5		4	.87-	SD25	11,0	Y-705RS	1249	

PRIMASTAR

Primastar dCi 80	1.9	60	4	03.01-		12,0	Y-732J	5605	4	
Primastar dCi 100	1.9	74	4	03.01-		12,0	Y-732J	5605	4	
Primastar 2.0 dCi	X83	2.0	66	4	09.06-	M9R692	4,5	Y1010AS	91210	88
Primastar 2.0 dCi	X83	2.0	66	4	02.07-	M9R782	7,0	CZ167	91063	91
Primastar 2.0 dCi	X83	2.0	66	4	02.07-	M9R786	7,0	CZ167	91063	91
Primastar 2.0 dCi	X83	2.0	66	4	01.12-	M9R630	4,5	Y1010AS	91210	88
Primastar 2.0 dCi	X83	2.0	84	4	09.06-	M9R692	4,5	Y1010AS	91210	88
Primastar 2.0 dCi	X83	2.0	84	4	02.07-	M9R780	7,0	CZ167	91063	91
Primastar 2.0 dCi	X83	2.0	84	4	02.07-	M9R786	7,0	CZ167	91063	91
Primastar 2.0 dCi	X83	2.0	84	4	02.07-12.11	M9R630	7,0	CZ167	91063	91
Primastar 2.0 dCi	X83	2.0	84	4	01.12-	M9R630	4,5	Y1010AS	91210	88
Primastar dCi 140	2.5	99	4	09.03-	G9U730	11,0	Y-517J	91766	66	
Primastar dCi 150	2.5	107	4	09.06-	G9U632	11,0	Y-517J	91766	66	

PRIMERA P10E

Primera	P10E	2.0	55	4	01.91-06.96	CD20	11,0	CZ260	91904	
---------	-------------	-----	----	---	-------------	------	------	-------	-------	--

PRIMERA P12

Primera 1.9 dCi P12	P12	1.9	88	4	09.03-	F9Q...	12,0	Y-732J	5605	4
Primera 2.2 Di P12	P12	2.2	93	4	03.02-	YD22ET	11,0	Y-519J	93293	61
Primera 2.2 dCi P12	P12	2.2	102	4	04.03-	YD22DDT	11,0	Y-519J	93293	61

QASHQAI I

Qashqai I 1.5 dCi	J10E, JJ10E	1.5	76	4	07.08-06.10	K9K	12,0	Y-732J	5605	4
Qashqai I 1.5 dCi	J10E, JJ10E	1.5	78	4	02.07-06.10	K9K	12,0	Y-732J	5605	4
Qashqai I 1.5 dCi	J10E, JJ10E	1.5	81	4	02.10-	K9K	4,4	Y1035AS	94103	77
Qashqai I 2.0 dCi	J10E	2.0	110	4	02.07-04.14	M9R	7,0	CZ167	91063	91





e kW C
y i



Stock-No
D-POWER

NISSAN

SERENA

Serena 2.0	C23M	2.0	49	4	07.92-01.96	LD20	11,0	CZ259	94154	
Serena 2.3	C23	2.3	55	4	01.95-02.98	LD23	11,0	Y-712RS	6140	
Serena 2.3	C23	2.3	55	4	03.98-	LD23	11,0	Y-530J	6586	

SUNNY B13

Sunny 1.7	B13	1.7	40	4	.93- .96	CD17	11,0	CZ259	94154	
-----------	------------	-----	----	---	----------	------	------	--------------	--------------	--

SUNNY B14

Sunny 2.0	B14	2.0	55	4	10.90-	CD20	11,0	CZ260	91904	
-----------	------------	-----	----	---	--------	------	------	--------------	--------------	--

SUNNY N14

Sunny 1.7	N14	1.7		4	.91- .91	CD17	11,0	CZ260	91904	
Sunny 2.0	N14	2.0	55	4	10.90- .95	CD20	11,0	CZ260	91904	

SUNNY N15

Sunny 2.0	N15	2.0	55	4	10.90- .95	CD20	11,0	CZ260	91904	
-----------	------------	-----	----	---	------------	------	------	--------------	--------------	--

SUNNY Y10

Sunny 1.7	Y10	1.7	40	4	.93- .96	CD17	11,0	CZ259	94154	
Sunny 2.0	Y10	2.0	55	4	10.90- .00	CD20	11,0	CZ260	91904	

SUNNY Y11

Sunny 1.7	Y11	1.7	40	4	05.92-04.98	CD17	11,0	CZ259	94154	
-----------	------------	-----	----	---	-------------	------	------	--------------	--------------	--

TERRANO I

Terrano I		2.5		4	- .95	TD25	11,0	Y-707RS	4937	
Terrano I		2.7		4	- .95	TD27	11,0	Y-707RS	4937	

TERRANO II

Terrano II Tdi R20 (only Europe)		2.7	92	4	05.96- .02	TD27T For EU	11,0	CZ261	97009	
Terrano II Tdi R20		2.7	92	4	10.99- .02	TD27TI R20	11,0	Y-712RS	6140	
Terrano II (not Europe)		2.7		4	07.93- .02	TD27T	11,0	Y-712RS	6140	
Terrano II R20		3.0	113	4	05.02-	ZD30DDT1 (only if NGK is OE)	11,0	CZ258	95173	

TINO 2.0 16V V10

Tino 2.0 16V V10		2.2	84	4	07.00-	YD22DT	11,0	Y-519J	93293	61
------------------	--	-----	----	---	--------	--------	------	---------------	--------------	-----------

URVAN / E20 / E23 / E24

Urvan / E20 / E23 / E24		2.2		4	09.80- .97	SD22	23,0	Y-181T	2728	
Urvan / E20 / E23 / E24		2.3		4	05.82- .97	SD23	23,0	Y-162R1	2431	
Urvan / E20 / E23 / E24		2.3		4	- .97	TD23	11,0	Y-707RS	4937	
Urvan / E20 / E23 / E24		2.7		4	.87- .97	TD27	11,0	Y-707RS	4937	

URVAN / E20 / E23 / E24 QGS TYPE 1

Urvan / E20 / E23 / E24 QGS Type 1		2.0		4	05.82- .97	LD20T	6,5	Y-204RS	4573	
Urvan / E20 / E23 / E24 QGS Type 1		2.3		4	05.82- .97	SD23	10,5	Y-112R1	1032	

URVAN E24L

Urvan E24L		2.5		4	.93- .97	TD25	11,0	Y-707RS	4937	
------------	--	-----	--	---	----------	------	------	----------------	-------------	--

URVAN QGS TYPE 2

Urvan QGS Type 2		2.3		4	05.82-	SD23	11,0	Y-112M1	2531	
------------------	--	-----	--	---	--------	------	------	----------------	-------------	--

VANETTE

Vanette		2.3	55	4	05.98-	LD23	11,0	Y-530J	6586	
---------	--	-----	----	---	--------	------	------	---------------	-------------	--

VANETTE C220

Vanette C220		2.0	44	4	04.87-11.94	LD20 II OHV	11,0	CZ259	94154	
Vanette C220		2.0	47	4	01.91-11.94	LD20 IIL	11,0	CZ259	94154	



e kW C
Y IStock-No
D-POWER**NISSAN****VANETTE CARGO**

Vanette Cargo	2,0	49	4	07.92-09.94	LD20 OHV	11,0	CZ259	94154	
---------------	-----	----	---	-------------	----------	------	--------------	--------------	--

VANETTE GC22

Vanette GC22	2,0	47	4	09.86-03.93	LD20 OHV	11,0	CZ259	94154	
--------------	-----	----	---	-------------	----------	------	--------------	--------------	--

X-TRAIL

X-Trail 2.0 dCi	T31, T31R	2,0	110	4	09.07-02.14	M9R	7,0	CZ167	91063	91
X-Trail 2.0 dCi	T31, T31R	2,0	110	4	09.07-02.14	M9R833	7,0	CZ167	91063	91
X-Trail 2.0 dCi	T31	2,0	127	4	06.07-02.14	M9R760	7,0	CZ167	91063	91
X-Trail 2.0 dCi	T31R	2,0	130	4	10.09-02.14	M9R760	7,0	CZ167	91063	91
X-Trail 2.0 dCi	T32	2,0	130	4	10.16-	M9R	4,5	Y1010AS	91210	88
X-Trail 2.2 Di	T30	2,2	84	4	09.01-10.03	YD22DDTi	11,0	Y-519J	93293	61
X-Trail 2.2 dCi	T30	2,2	100	4	11.03-	YD22DDTi	11,0	Y-519J	93293	61

OPEL**AGILA**

Agila 1.3 CDTI	1,3	51	4	08.03-04.08	Z13DT	11,0	Y8003J	97256	62
----------------	-----	----	---	-------------	-------	------	---------------	--------------	-----------

ANTARA

Antara 2.0 CDTI	L07	2,0	93	4	09.08-12.11	Z20DM	4,4	Y8009AS	96478	
Antara 2.0 CDTI	L07	2,0	110	4	05.06-12.11	Z20DMH	4,4	Y8009AS	96478	
Antara 2.2 CDTi	L07	2,2	120	4	12.10-	A22DM	4,4	Y8010AS	93503	
Antara 2.2 CDTi	L07	2,2	135	4	12.10-	A22DMH	4,4	Y8010AS	93503	

ARENA

Arena 1.9D	1,9	44	4	01.98-04.03	F8Q600, F8Q606	11,0	Y-506J	2419	7
Arena 2.5D	2,5	55	4	07.98-02.01	S8U758	11,0	Y-924J	7906	1
Arena 2.5D	2,5	55	4	07.98-02.01	S8U780, S8U782	11,0	Y-924J	7906	1

ASTRA F

Astra F 1.7 D	1,7	42	4	09.91-09.92	17D OHC II	11,0	Y-924J	7906	1
Astra F 1.7 D	1,7	44	4	09.92-08.94	17DR	11,0	Y-924J	7906	1
Astra F 1.7 TD	1,7	50	4	08.94-02.98	X17 DTL	11,0	Y-924J	7906	1
Astra F 1.7 TD (Isuzu Engine No 956633->)	1,7	60	4	12.91-02.98	17DT (TC4EE1) OHC	11,0	Y-603J	8838	60
Astra F 1.7 TD (Isuzu Engine No 956633->)	1,7	60	4	04.96-02.98	X17DT (TC4EE1) OHC	11,0	Y-603J	8838	60

ASTRA G

Astra G 1.7 TD	1,7	50	4	02.98-08.00	X17DTL	11,0	Y-924J	7906	1
Astra G 1.7 DTI	1,7	55	4	02.00-01.05	Y17DT	11,0	Y-541J	1983	42
Astra G 1.7 CDTI	1,7	59	4	04.03-01.05	Z17DTL	11,0	Y-541J	1983	42
Astra G 2.0 Di	2,0	60	4	02.98-01.05	X20DTL SOHC	11,0	Y-748U	6649	14
Astra G 2.0 DI II	2,0	60	4	08.00-01.05	Y20DTL	11,0	Y-748U	6649	14
Astra G 2.0 DTI (Chassis No 3H000001->)	2,0	74	4	08.00-01.05	Y20DTH	11,0	Y-523J	6298	37
Astra G 2.0 DTI (Chassis No->2H999999)	2,0	74	4	08.00-01.05	Y20DTH	11,0	Y-748U	6649	14
Astra G 2.2 DTI	2,2	92	4	.03-01.05	Y22DTR	11,0	Y-523J	6298	37

ASTRA H

Astra H 1.3 CDTI	1,3	66	4	06.04-	Z13DTH	11,0	Y8003J	97256	62
Astra H 1.7 CDTI	1,7	59	4	03.04-12.09	Z17DTL	11,0	Y-541J	1983	42
Astra H 1.7 CDTI	1,7	74	4	03.04-12.12	Z17DTH	11,0	Y-541J	1983	42
Astra H 1.7 CDTI	1,7	92	4	02.07-10.15	A17DTR	11,0	Y-541J	1983	42





l kW C
y I



Stock-No
D-POWER™

OPEL

ASTRA H

Astra H 1.7 CDTI	1.7	92	4	03.07-	Z17DTR	11,0	Y-541J	1983	42
Astra H 1.9 CDTI (VIN 72045140->)	1.9	74	4	09.05-12.12	Z19DTL	11,0	Y1030J	90828	70
Astra H 1.9 CDTI (VIN->72045139)	1.9	74	4	09.05-12.12	Z19DTL	11,0	Y-534J	3413	36
Astra H 1.9 CDTI (VIN 72045140->)	1.9	88	4	04.04-12.12	Z19DT	11,0	Y1030J	90828	70
Astra H 1.9 CDTI (VIN->72045139)	1.9	88	4	04.04-12.12	Z19DT	11,0	Y-534J	3413	36
Astra H 1.9 CDTI	1.9	88	4	04.05-12.12	Z19DTJ	11,0	YE07	6092	
Astra H 1.9 CDTI 16V	1.9	110	4	09.04-12.12	Z19DTH	11,0	YE07	6092	

ASTRA J

Astra J 1.3 CDTI for cylinder without pressure sensor	1.3	70	4	12.09-10.15	A13DTE	4,4	Y9004AS	90860	
Astra J 1.7 CDTI	1.7	81	4	10.09-10.15	A17DTJ	11,0	Y-541J	1983	42
Astra J 1.7 CDTI	1.7	92	4	10.09-10.15	A17DTR	11,0	Y-541J	1983	42

CAMPO

Campo 2.5 TD	2.5	56	4	07.94-07.01	4JA1T (25 DT)	11,0	Y-904M1	7995	
Campo 3.1 TD	3.1	80	4	09.92-12.02	4JG2T (31TD/TDS)	11,0	Y-719RS1	6900	

COMBO

Combo 1.3 CDTI	1.3	51	4	10.04-01.12	Y13DT	11,0	Y8003J	97256	62	
Combo 1.3 CDTI	1.3	55	4	10.05-01.12	Y13DTJ	11,0	Y8003J	97256	62	
OPEL Combo 1.3 CDTi (For OE-No. 55238404 / 1214106)	C06	1.3	66	4	11.11-	A13FD	4,3	Y9001AS	97719	72
OPEL Combo 1.3 CDTi (For OE-No. 55238404 / 1214106)	B05, C06	1.3	70	4	11.15-	A13FD	4,3	Y9001AS	97719	72
Combo 1.7	1.7	44	4	07.94-10.01	17D (4EE1) OHC	11,0	Y-603J	8838	60	
Combo 1.7	1.7	44	4	04.96-10.01	X17D (4EE1) OHC	11,0	Y-603J	8838	60	
Combo 1.7 DI 16V	1.7	48	4	10.01-06.04	Y17DTL	11,0	Y-541J	1983	42	
Combo 1.7 DTI 16V	1.7	55	4	10.01-06.04	Y17DT	11,0	Y-541J	1983	42	
Combo 1.7 CDTI 16V	1.7	74	4	12.04-12.12	Z17DTH	11,0	Y-541J	1983	42	

CORSA A

Corso A 1.5 D (Isuzu Engine No->804794)	1.5	37	4	09.87-03.93	15D (4EC1)	5,0	Y-306R	6244	
Corso A 1.5 D (Isuzu Engine No 804795->)	1.5	37	4	09.87-03.93	15D (4EC1)	11,0	Y-710J	7880	

CORSA B

Corso B 1.5 D (Isuzu Engine)	1.5	37	4	03.93-08.00	15D (4EC1) OHC	11,0	Y-603J	8838	60
Corso B 1.5 TD (Isuzu Engine)	1.5	49	4	03.93-08.00	X15DT (T4EC1) OHC	11,0	Y-603J	8838	60
Corso B 1.5 D	1.5	49	4	04.96-08.01	X15DT (4EE1) OHC	11,0	Y-603J	8838	60
Corso B 1.7 TD	1.7	44	4	03.93-08.00	17D (4EE1) OHC	11,0	Y-603J	8838	60
Corso B 1.7 D	1.7	44	4	04.96-08.01	X17D (4EE1) OHC	11,0	Y-603J	8838	60

CORSA C

Corso C 1.3 CDTI	1.3	51	4	06.03-07.06	Z13DT	11,0	Y8003J	97256	62
Corso C 1.7 DI 16V	1.7	48	4	08.00-07.03	Y17DTL	11,0	Y-541J	1983	42
Corso C 1.7 DTI 16V	1.7	55	4	08.00-07.03	Y17DT	11,0	Y-541J	1983	42
Corso C 1.7 CDTI	1.7	74	4	06.03-07.06	Z17DTH	11,0	Y-541J	1983	42

CORSA D

Corso D 1.3 DTI 16V	1.3	55	4	07.06-08.14	Z13DTJ	11,0	Y8003J	97256	62
Corso D 1.3 CDTI for cylinder without pressure sensor	1.3	55	4	06.10-08.14	A13DTC	4,4	Y9004AS	90860	
Corso D 1.3 CDTI	1.3	66	4	07.05-08.14	Z13DTH	11,0	Y8003J	97256	62
Corso D 1.3 CDTI	1.3	70	4	06.10-08.14	A13DTR	4,4	Y9004AS	90860	





l kW C
Y
I



Stock-No
D-POWER

OPEL

CORSA D

Corsa D 1.3 CDTi	1.3	70	4	06.10-08.14	Z13DTR	4,4	Y9004AS	90860	
Corsa D 1.3 CDTi ECOTEC	1.3	70	4	06.10-08.14	Z13DTE	4,4	Y9004AS	90860	
Corsa D 1.7 CDTi	1.7	92	4	07.06-08.14	Z17DTR	11,0	Y-541J	1983	42

CORSA E

OPEL Corsa E 1.3 CDTi (For OE-No. 55238404 / 1214106)	08, 68, 05	1.3	55	4	09.14-	B13DTC	4,3	Y9001AS	97719	72
OPEL Corsa E 1.3 CDTi (For OE-No. 55238404 / 1214106)	08, 68, 05	1.3	70	4	09.14-	B13DTE	4,3	Y9001AS	97719	72
OPEL Corsa E 1.3 CDTi (For OE-No. 55238404 / 1214106)	08, 68, 05	1.3	70	4	09.14-	B13DTR	4,3	Y9001AS	97719	72

FRONTERA A

Frontera A 2.3 TD	2.3	74	4	09.91-02.95	23 DTR OHC	11,0	Y-924J	7906	1
Frontera A 2.3 TD	2.3	74	4	03.92-09.95	DTR OHC	11,0	Y-924J	7906	1
Frontera A 2.5 TDI	2.5	85	4	06.96-08.98	25TD VM41B (25TDS)	11,0	Y-741U	6943	20
Frontera A 2.5 TDI	2.5	85	4	09.96-10.98	25TD, TDS, OHC	11,0	Y-741U	6943	20
Frontera A 2.8 TDI (Isuzu Engine)	2.8	83	4	02.95-11.98	28TD 4JB1T (28TDI)	11,0	Y-904M1	7995	

FRONTERA B

Frontera B 2.2 DTI 16V	2.2	85	4	10.98-09.02	Y22DTH	11,0	Y-523J	6298	37
Frontera B 2.2 DTI 16V	2.2	85	4	10.98-09.02	X22DTH	11,0	Y-748U	6649	14

INSIGNIA

Insignia 2.0 CDTi (only for cyl. without pressure sensor)	2.0	96	4	07.08-	A20DT	4,4	Y9003AS	94251	78
Insignia 2.0 CDTi (only for cyl. without pressure sensor)	2.0	96	4	07.08-	A20DTJ	4,4	Y9003AS	94251	78

KADETT E

Kadett E 1.7 D	1.7	42	4	02.89-09.92	17D OHC II	11,0	Y-924J	7906	1
Kadett E 1.7 D	1.7	44	4	09.92-09.93	17DR	11,0	Y-924J	7906	1

MERIVA A

Meriva A 1.3 CDTi ECOTEC	1.3	55	4	09.03-05.10	Z13DTJ	11,0	Y8003J	97256	62
Meriva A 1.7 DTI	1.7	55	4	09.03-05.10	Y17DT	11,0	Y-541J	1983	42
Meriva A 1.7 CDTi	1.7	74	4	09.03-05.10	Z17DTH	11,0	Y-541J	1983	42
Meriva A 1.7 CDTi	1.7	92	4	09.06-05.10	Z17DTR	11,0	Y-541J	1983	42
Meriva A 1.7 CDTi	1.7	92	4	01.08-05.10	A17DTR	11,0	Y-541J	1983	42

MERIVA B

Meriva B 1.3 CDTi for cylinder without pressure sensor	1.3	55	4	06.10-	A13DTC	4,4	Y9004AS	90860	
Meriva B 1.3 CDTi for cylinder without pressure sensor	1.3	70	4	03.10-	A13DTE	4,4	Y9004AS	90860	
Meriva B 1.7 CDTi	1.7	74	4	03.10-	A17DT	11,0	Y-541J	1983	42

MONTEREY A

Monterey A 3.1 TD	3.1	84	4	11.91-02.98	4JG2-TC (3.1 D)	11,0	Y-719RS1	6900	
-------------------	-----	----	---	-------------	-----------------	------	----------	------	--

MONTEREY B

Monterey B 3.0 DTI	3.0	117	4	02.98-10.99	4JX1 (3.0 DTI)	11,0	Y1038J	94542	
--------------------	-----	-----	---	-------------	----------------	------	--------	-------	--

MOVANO

Movano 1.9 DTI	1.9	59	4	09.00-	F9Q M7	12,0	Y-732J	5605	4
Movano 2.2 DTI	2.2	66	4	09.00-	G9T C7	11,0	Y-517J	91766	66
Movano 2.3 CDTi (color code: Red)	HV, UV, FV	2.3	74	4	05.10-	M9T690	4,5	Y1047AS	95340
Movano 2.3 CDTi (color code: Red)	HV, UV, FV	2.3	74	4	05.10-	M9T692	4,5	Y1047AS	95340
Movano 2.3 CDTi (color code: Red)	HV, UV, FV	2.3	74	4	05.10-	M9T890	4,5	Y1047AS	95340
Movano 2.3 CDTi (color code: Red)	HV, UV, FV	2.3	74	4	05.10-	M9T892	4,5	Y1047AS	95340





e kW C
y i



Stock-No
D-POWER™

OPEL

MOVANO

Movano 2.3 CDTi (color code: Red)	JV, EV, HV, UV, FV	2.3	81	4	05.14-	M9T704		4,5	Y1047AS	95340	
Movano 2.3 CDTi (color code: Red)	JV, EV, HV, UV, FV	2.3	81	4	05.14-	M9T870		4,5	Y1047AS	95340	
Movano 2.3 CDTi (color code: Red)	EV, HV, UV, FV	2.3	92	4	12.12-	M9T890		4,5	Y1047AS	95340	
Movano 2.3 CDTi (color code: Red)	EV, HV, UV	2.3	92	4	05.13-	M9T896		4,5	Y1047AS	95340	
Movano 2.3 CDTi (color code: Red)	EV, HV, UV, FV	2.3	92	4	05.13-	M9T898		4,5	Y1047AS	95340	
Movano 2.3 CDTi (color code: Red)	EV, HV, UV, FV	2.3	96	4	11.16-	M9T710		4,5	Y1047AS	95340	
Movano 2.3 CDTi (color code: Red)	FV, EV, HV, UV	2.3	96	4	11.16-	M9T704		4,5	Y1047AS	95340	
Movano 2.3 CDTi (color code: Red)	FV, JV, EV, HV, UV	2.3	100	4	05.14-	M9T702		4,5	Y1047AS	95340	
Movano 2.3 CDTi (color code: Red)	JV, EV, HV, UV, FV	2.3	100	4	05.14-	M9T716		4,5	Y1047AS	95340	
Movano 2.3 CDTi (color code: Red)	HV, UV, FV	2.3	100	4	05.14-	M9T700		4,5	Y1047AS	95340	
Movano 2.3 CDTi (color code: Red)	EV, HV, UV, FV, JV	2.3	107	4	05.10-	M9T706		4,5	Y1047AS	95340	
Movano 2.3 CDTi (color code: Red)	EV, HV, UV, FV	2.3	107	4	05.10-	M9T708		4,5	Y1047AS	95340	
Movano 2.3 CDTi (color code: Red)	EV, HV, UV, FV	2.3	107	4	05.10-	M9T710		4,5	Y1047AS	95340	
Movano 2.3 CDTi (color code: Red)	EV, HV, UV, FV	2.3	107	4	05.13-	M9T896		4,5	Y1047AS	95340	
Movano 2.3 CDTi (color code: Red)	EV, HV, UV, FV	2.3	107	4	05.13-	M9T898		4,5	Y1047AS	95340	
Movano 2.3 CDTi (color code: Red)	EV, FV, HV, JV, UV	2.3	107	4	07.13-	M9T880		4,5	Y1047AS	95340	
Movano 2.3 CDTi (color code: Red)	JV, EV, HV, UV, FV	2.3	110	4	01.13-	M9T716		4,5	Y1047AS	95340	
Movano 2.3 CDTi (color code: Red)	EV, FV, HV, JV, UV	2.3	110	4	01.13-	M9T880		4,5	Y1047AS	95340	
Movano 2.3 CDTi (color code: Red)	JV, EV, HV, UV	2.3	120	4	05.14-	M9T702		4,5	Y1047AS	95340	
Movano 2.3 CDTi (color code: Red)	HV, UV, FV	2.3	120	4	05.14-	M9T700		4,5	Y1047AS	95340	
Movano 2.3 CDTi (color code: Red)	HV, UV, FV	2.3	120	4	05.14-	M9T710		4,5	Y1047AS	95340	
Movano 2.3 CDTi (color code: Red)	JV, FV, EV, HV, UV	2.3	125	4	05.15-	M9T706		4,5	Y1047AS	95340	
Movano 2.5 D		2.5	59	4	10.98-10.00	S8U W7		11,5	Y-910J	3617	3
Movano 2.5 DTi		2.5	73	4	10.03-	G9U 754		11,0	Y-517J	91766	66
Movano 2.5 CDTi		2.5	74	4	08.06-	G9U 650		11,0	Y-517J	91766	66
Movano 2.5 DTi		2.5	84	4	10.01-	G9U720, G9U724		11,0	Y-517J	91766	66
Movano 2.5 CDTi		2.5	88	4	08.06-	G9U 650		11,0	Y-517J	91766	66
Movano 2.5 CDTi		2.5	107	4	08.06-	G9U 650		11,0	Y-517J	91766	66

MOVANO B

Movano B 2.3 CDTi (color code: White)	HV, UV, JV, FV	2.3	74	4	05.10-	M9T672		7,0	CZ167	90646	91
Movano B 2.3 CDTi (color code: White)	FV, HV, UV, JV	2.3	74	4	05.10-	M9T670		7,0	CZ167	90646	91
Movano B 2.3 CDTi (color code: White)	FV, HV, UV, JV	2.3	74	4	05.10-	M9T676		7,0	CZ167	90646	91
Movano B 2.3 CDTi (color code: White)	FV, HV, UV, JV	2.3	74	4	05.10-	M9T870		7,0	CZ167	90646	91
Movano B 2.3 CDTi (color code: White)	FV, HV, UV, JV	2.3	74	4	05.10-	M9T876		7,0	CZ167	90646	91
Movano B 2.3 CDTi (color code: White)	FV, HV, UV	2.3	74	4	05.10-	M9T690		7,0	CZ167	90646	91
Movano B 2.3 CDTi (color code: White)	FV, HV, UV	2.3	74	4	05.10-	M9T692		7,0	CZ167	90646	91
Movano B 2.3 CDTi (color code: White)	FV, HV, UV	2.3	74	4	05.10-	M9T892		7,0	CZ167	90646	91
Movano B 2.3 CDTi (color code: White)	EV, HV, UV	2.3	92	4	05.10-	M9T696		7,0	CZ167	90646	91





ℓ kW C
Y
I



Stock-No
D-POWER

OPEL

MOVANO B

Movano B 2.3 CDTi (color code: White)	EV, HV, UV	2.3	92	4	05.10-04.13	M9T896	7,0	CZ167	90646	91
Movano B 2.3 CDTi (color code: White)	FV, EV, HV, UV, JV	2.3	92	4	05.10-	M9T672	7,0	CZ167	90646	91
Movano B 2.3 CDTi (color code: White)	FV, EV, HV, UV, JV	2.3	92	4	05.10-	M9T676	7,0	CZ167	90646	91
Movano B 2.3 CDTi (color code: White)	FV, EV, HV, UV, JV	2.3	92	4	05.10-	M9T870	7,0	CZ167	90646	91
Movano B 2.3 CDTi (color code: White)	FV, EV, HV, UV, JV	2.3	92	4	05.10-	M9T876	7,0	CZ167	90646	91
Movano B 2.3 CDTi (color code: White)	FV, EV, HV, UV	2.3	92	4	05.10-	M9T880	7,0	CZ167	90646	91
Movano B 2.3 CDTi (color code: White)	FV, EV, HV, UV	2.3	92	4	05.10-	M9T690	7,0	CZ167	90646	91
Movano B 2.3 CDTi (color code: White)	FV, EV, HV, UV	2.3	92	4	05.10-	M9T692	7,0	CZ167	90646	91
Movano B 2.3 CDTi (color code: White)	FV, EV, HV, UV	2.3	92	4	05.10-11.12	M9T890	7,0	CZ167	90646	91
Movano B 2.3 CDTi (color code: White)	FV, EV, HV, UV	2.3	92	4	05.10-	M9T892	7,0	CZ167	90646	91
Movano B 2.3 CDTi (color code: White)	FV, EV, HV, UV	2.3	92	4	05.10-04.13	M9T898	7,0	CZ167	90646	91
Movano B 2.3 CDTi (color code: White)	JV, HV, UV7, EV, FV	2.3	92	4	05.10-	M9T670	7,0	CZ167	90646	91
Movano B 2.3 CDTi (color code: White)	FV, JV, EV, HV, UV	2.3	107	4	05.10-	M9T678	7,0	CZ167	90646	91
Movano B 2.3 CDTi (color code: White)	FV, JV, EV, HV, UV	2.3	107	4	05.10-	M9T680	7,0	CZ167	90646	91
Movano B 2.3 CDTi (color code: White)	FV, JV, EV, HV, UV	2.3	107	4	05.10-06.13	M9T880	7,0	CZ167	90646	91
Movano B 2.3 CDTi (color code: White)	FV, EV, HV, UV	2.3	107	4	05.10-	M9T694	7,0	CZ167	90646	91
Movano B 2.3 CDTi (color code: White)	EV, FV, HV, UV	2.3	107	4	05.10-	M9T696	7,0	CZ167	90646	91
Movano B 2.3 CDTi (color code: White)	FV, EV, HV, UV	2.3	107	4	05.10-	M9T698	7,0	CZ167	90646	91
Movano B 2.3 CDTi (color code: White)	FV, EV, HV, UV	2.3	107	4	05.10-04.13	M9T896	7,0	CZ167	90646	91
Movano B 2.3 CDTi (color code: White)	FV, EV, HV, UV	2.3	107	4	05.10-04.13	M9T898	7,0	CZ167	90646	91
Movano B 2.3 CDTi (color code: White)	FV, JV, EV, HV, UV	2.3	110	4	01.13-	M9T716	7,0	CZ167	90646	91
Movano B 2.3 CDTi (color code: White)	FV, JV, EV, HV, UV	2.3	110	4	01.13-	M9T880	7,0	CZ167	90646	91
Movano B 2.3 CDTi (color code: White)	FV, HV, UV	2.3	110	4	01.13-	M9T694	7,0	CZ167	90646	91
Movano B 2.3 CDTi (color code: White)	FV, HV, UV	2.3	110	4	01.13-	M9T696	7,0	CZ167	90646	91
Movano B 2.3 CDTi (color code: White)	FV, HV, UV	2.3	110	4	01.13-	M9T698	7,0	CZ167	90646	91

OMEGA A

Omega A 2.3 D		2.3	54	4	09.86-02.94	23 YD OHC	11,0	Y-924J	7906	1
Omega A 2.3 TD		2.3	74	4	09.88-02.94	23 DTR OHC	11,0	Y-924J	7906	1

OMEGA B

Omega B 2.0 DTI		2.0	74	4	09.97-07.00	X20DTH	11,0	Y-748U	6649	14
Omega B 2.0 D		2.0	74	4	10.98-09.00	X20DTH OHC	11,0	Y-748U	6649	14
Omega B 2.0 DTI		2.0	74	4	09.99-04.02	Y20DTH	11,0	Y-523J	6298	37
Omega B 2.2 DTI		2.2	88	4	05.01-07.03	Y22DTR	11,0	Y-523J	6298	37
Omega B 2.2 DTI		2.2	88	4	08.01-04.02	Y22DTH	11,0	Y-523J	6298	37
Omega B 2.5 TD		2.5	96	6	02.94-02.96	U25TD (BMW)	11,0	Y-924J	7906	1
Omega B 2.5 TD		2.5	96	6	08.96-10.01	X25DT OHC	11,0	Y-924J	7906	1

SIGNUM

Signum 1.9 CDTi (VIN 71021892->)		1.9	74	4	08.05-02.08	Z19DTL	11,0	Y1030J	90828	70
Signum 1.9 CDTi (VIN->71021891)		1.9	74	4	08.05-02.08	Z19DTL	11,0	Y-534J	3413	36





l kW C
y i



Stock-No
D-POWER

OPEL

SIGNUM

Signum 1.9 CDTi (VIN 71021892→)	1.9	88	4	04.04-10.08	Z19DT	11,0	Y1030J	90828	70
Signum 1.9 CDTi (VIN→71021891)	1.9	88	4	04.04-10.08	Z19DT	11,0	Y534J	3413	36
Signum 1.9 CDTi	1.9	110	4	04.04-02.08	Z19DTH	11,0	YE07	6092	
Signum 2.0 DTI	2.0	74	4	05.03-04.04	Y20DTH	11,0	Y523J	6298	37
Signum 2.2 DTI	2.2	92	4	05.03-04.04	Y22DTR	11,0	Y523J	6298	37
Signum 3.0 CDTi F48	3.0	130	6	05.03-07.05	Y30DT	11,0	CZ24	92070	
Signum 3.0 CDTi F48	3.0	135	6	08.05-12.08	Z30DT	11,0	CZ24	92070	

SINTRA

Sintra 2.2 DTI	2.2	85	4	01.98-	X22DTH	11,0	Y-748U	6649	14
----------------	-----	----	---	--------	--------	------	--------	------	----

TIGRA B

Tigra B 1.3 CDTi	1.3	52	4	06.04-12.10	Z13DT	11,0	Y8003J	97256	62
------------------	-----	----	---	-------------	-------	------	--------	-------	----

VECTRA A

Vectra A 1.7 D	1.7	42	4	02.88-09.92	17D OHC II	11,0	Y-924J	7906	1
Vectra A 1.7 TD (Isuzu Engine No 817253→)	1.7	60	4	03.90-	TC4EC1	11,0	Y-711J	4467	28
Vectra A 1.7 TD (Isuzu Engine)	1.7	60	4	10.92-08.95	17DT (TC4EE1)	11,0	Y-603J	8838	60

VECTRA B

Vectra B 1.7 TD (Isuzu Engine)	1.7	60	4	08.95-12.98	X17TD (TC4EE1)	11,0	Y-603J	8838	60
Vectra B 2.0 Di	2.0	60	4	08.96-07.99	X20DTL SOHC	11,0	Y-604J	6157	
Vectra B 2.0 Di	2.0	60	4	08.99-04.02	X20DTL SOHC	11,0	Y-748U	6649	14
Vectra B 2.0 DTI	2.0	74	4	08.97-04.02	X20DTH OHC	11,0	Y-748U	6649	14
Vectra B 2.0 DTI	2.0	74	4	09.97-07.99	X20DILC	11,0	Y-748U	6649	14
Vectra B 2.0 DTI	2.0	74	4	08.00-04.02	Y20DTH	11,0	Y-523J	6298	37
Vectra B 2.2 DTI	2.2	92	4	08.00-04.02	Y22DTR	11,0	Y-523J	6298	37

VECTRA C

Vectra C 1.9 CDTi (VIN 71021892→)	1.9	74	4	06.05-08.08	Z19DTL	11,0	Y1030J	90828	70
Vectra C 1.9 CDTi (VIN→71021891)	1.9	74	4	06.05-08.08	Z19DTL	11,0	Y534J	3413	36
Vectra C 1.9 CDTi (VIN 71021892→)	1.9	88	4	04.04-08.08	Z19DT	11,0	Y1030J	90828	70
Vectra C 1.9 CDTi (VIN→71021891)	1.9	88	4	04.04-08.08	Z19DT	11,0	Y534J	3413	36
Vectra C 1.9 CDTi	1.9	110	4	04.04-08.08	Z19DTH	11,0	YE07	6092	
Vectra C 2.0 DTI	2.0	74	4	04.02-08.05	Y20DTH	11,0	Y523J	6298	37
Vectra C 2.0 DTI	2.2	92	4	04.02-07.04	Y22DTR	11,0	Y523J	6298	37
Vectra C 3.0 CDTi F68, F69, F35	3.0	130	6	02.03-07.05	Y30DT	11,0	CZ24	92070	
Vectra C 3.0 CDTi F35, F68, F69	3.0	135	6	08.05-08.08	Z30DT	11,0	CZ24	92070	

VIVARO

Vivaro 1.6 CDTi 05	1.6	66	4	06.14-	R9M408	4,5	Y1010AS	97618	88
Vivaro 1.6 CDTi 05	1.6	70	4	03.16-	R9M408	4,5	Y1010AS	97618	88
Vivaro 1.6 CDTi 05	1.6	85	4	06.14-	R9M408	4,5	Y1010AS	97618	88
Vivaro 1.6 CDTi 03	1.6	103	4	08.15-	R9M450	4,5	Y1010AS	97618	88
Vivaro 1.9 DTI	1.9	74	4	09.01-07.14	F9Q 760	12,0	Y-732J	5605	4
Vivaro 2.0 CDTi (color code: Yellow) F7A, F7B, E7B	2.0	66	4	08.06-07.14	M9R630	4,5	Y1010AS	91210	88
Vivaro 2.0 CDTi (color code: Yellow) F7A, F7B, E7B	2.0	66	4	08.06-07.14	M9R692	4,5	Y1010AS	91210	88
Vivaro 2.0 CDTi (Engine No C056227→; color code: White) J7A, J7B, F7A, F7B	2.0	66	4	02.07-07.14	M9R780	7,0	CZ167	91063	91
Vivaro 2.0 CDTi (engine color code: White) F7A, F7B, E7B	2.0	66	4	02.07-07.14	M9R630	7,0	CZ167	91063	91





e kW C
Y
I



Stock-No
D-POWER

OPEL

VIVARO

Vivaro 2.0 CDTi (color code: Yellow)	F7A, F7B, J7A, J7B, E7B	2.0	84	4	08.06-07.14	M9R692	4,5	Y1010AS	91210	88
Vivaro 2.0 CDTi (Engine No C056227→/ color code: White)	J7A, J7B, F7A, F7B, E7B	2.0	84	4	02.07-07.14	M9R780	7,0	CZ167	91063	91
Vivaro 2.5 CDTI		2.5	84	4	08.06-03.10	G9U720, G9U730	11,0	Y-517J	91766	66
Vivaro 2.5 DTI		2.5	98	4	05.03-07.14	G9U 730	11,0	Y-517J	91766	66
Vivaro 2.5 CDTI		2.5	107	4	08.06-	G9U 630	11,0	Y-517J	91766	66
Vivaro X82 1.6 CDTi (color code: Yellow; For Cyl. 2/3/4)	05	1.6	70	4	03.16-	R9M413	4,5	Y1010AS	91210	88
Vivaro X82 1.6 CDTi (color code: Yellow; For Cyl. 2/3/4)	05	1.6	89	4	03.16-	R9M413	4,5	Y1010AS	91210	88
Vivaro X82 1.6 CDTi (color code: Yellow; For Cyl. 2/3/4)	5	1.6	92	4	03.16-	R9M452	4,5	Y1010AS	91210	88
Vivaro X82 1.6 CDTi (color code: Yellow; For Cyl. 2/3/4)	05	1.6	107	4	03.16-	R9M452	4,5	Y1010AS	91210	88
Vivaro X82 1.6 CDTi (color code: Yellow; For Cyl. 2/3/4)	03	1.6	107	4	11.16-	R9M452	4,5	Y1010AS	91210	88

ZAFIRA A

Zafira A 2.0 DI	F75	2.0	60	4	09.99-11.00	X20DTL	11,0	Y-748U	6649	14
Zafira A 2.0 DTI	F75	2.0	74	4	04.99-	X20DILC	11,0	Y-748U	6649	14
Zafira A 2.0 DTI	F75	2.0	74	4	08.99-06.05	Y20DTL	11,0	Y-748U	6649	14
Zafira A 2.0 DTI	F75	2.0	74	4	08.00-06.05	Y20DTH	11,0	Y-523J	6298	37
Zafira A 2.2 DTI	F75	2.2	92	4	01.02-06.05	Y22DTR	11,0	Y-523J	6298	37

ZAFIRA B

Zafira B 1.7 CDTi/ CDTI ECOTEC	A05	1.7	81	4	01.08-	A17DTJ	11,0	Y-541J	1983	42
Zafira B 1.7 CDTI	A05	1.7	92	4	01.08-	A17DTR	11,0	Y-541J	1983	42
Zafira B 1.9 CDTi (VIN 72000001→)	A05	1.9	74	4	07.05-	Z19DTL	11,0	Y1030J	90828	70
Zafira B 1.9 CDTi (VIN→62999999)	A05	1.9	74	4	07.05-12.10	Z19DTL	11,0	Y-534J	3413	36
Zafira B 1.9 CDTi (VIN 72000001→)	A05	1.9	88	4	07.05-	Z19DT	11,0	Y1030J	90828	70
Zafira B 1.9 CDTi (VIN→62999999)	A05	1.9	88	4	07.05-	Z19DT	11,0	Y-534J	3413	36
Zafira B 1.9 CDTI	A05	1.9	110	4	07.05-	Z19DTH	11,0	YE07	6092	

PEUGEOT

1007

1007 Hdi		1.4	51	4	01.05-	DV4TD	11,0	YE05	91322	73
1007 1.6 Hdi		1.6	80	4	06.07-	DV6TED4	11,0	YE05	91322	73

106

106 D		1.4	37	4	08.91-06.94	TUD3, L	11,5	Y-910J	3617	3
106 D		1.5	42	4	07.94-03.96	TUD5	11,0	Y-503J	1009	10
106 D		1.5	42	4	04.96-10.03	TUD5	11,0	Y-503J	1009	10

107

107 Hdi		1.4	51	4	01.05-	DV4TD	11,0	YE04	1684	40
107 Hdi		1.4	51	4	01.05-	DV4	11,0	YE05	91322	73
107 Hdi		1.6	68	4	04.05-	DV6TD	11,0	YE04	1684	40

2008

2008 1.6 e-HDi 92		1.6	68	4	03.13-	DV6TED4	5,0	Y8001AS	8904	58
2008 1.6 e-HDi 115		1.6	84	4	03.13-	DV6C	5,0	Y8001AS	8904	58

205

205 D		1.8	44	4	10.83-08.98	XUD7	11,0	Y-924J	7906	1
-------	--	-----	----	---	-------------	------	------	--------	------	---





e kW C
y
i



Stock-No
D-POWER™

PEUGEOT

205

205 D	1.8	44	4	09.98-12.99	XUD7	11,0	Y-924J	7906	1
205 TD	1.8	58	4	07.85-08.98	XUD7T	11,0	Y-924J	7906	1
205	1.8	58	4	09.98-12.99	XUD7T	11,0	Y-924J	7906	1
205 D	1.9	47	4	10.87-08.98	XUD9	11,0	Y-924J	7906	1
205	1.9	51	4	09.98-12.99	XUD9A	11,0	Y-924J	7906	1

206

206 & SW Hdi	1.4	51	4	11.01-12.04	DV4TD	11,0	YE04	1684	40
206 & SW	1.4	51	4	12.04-	DV4TD	11,0	YE05	91322	73
206 D	1.9	51	4	09.98-	DW8, DW8B	11,0	Y-503J	1009	10
206 & SW Hdi	2.0	66	4	10.99-	DW10TD	11,0	Y-504J	1441	24

206 & SW

206 & SW Hdi	1.4	51	4	09.01-12.04	DV4TD	11,0	YE04	1684	40
206 & SW Hdi	1.6	81	4	.04-06.06	DV6TED4	11,0	YE04	1684	40

206 PLUS

206 Plus 1.4 Hdi	2L8HRA, 2L8HZA, 2M8HRA, 2M8HZA	1.4	50	4	01.09-06.13	DV4C	11,0	YE05	91322	73
206 Plus 1.4 Hdi Urban, Trendy		1.4	50	4	03.09-	DV4TD	11,0	YE05	91322	73

207

207 1.4 Hdi	WA8HRC, WA8HZC, WC8HRC, WC8HZC	1.4	50	4	04.06-12.15	DV4C	11,0	YE05	91322	73
207 Hdi		1.4	51	4	07.06-	DV4TD	11,0	YE04	1684	40
207 Hdi		1.6	66	4	07.06-	DV6TED	11,0	YE04	1684	40
207 1.6 Hdi 90		1.6	66	4	06.07-	DV6ATED4	11,0	YE05	91322	73
207 & SW		1.6	80	4	06.07-	DV6TED4	11,0	YE05	91322	73
207 Hdi 16V		1.6	81	4	07.06-	DV6TED4	11,0	YE04	1684	40
207 Hdi		1.6	81	4	07.06-	DV6	11,0	YE05	91322	73
207 1.6 Hdi 110		1.6	82	4	08.09-	DV6C	5,0	Y8001AS	8904	58

207 CC

207 CC 1.6 Hdi	WD9HR8	1.6	82	4	12.09-10.13	DV6C	5,0	Y8001AS	8904	58
----------------	--------	-----	----	---	-------------	------	-----	---------	------	----

207 PLUS

207 Plus 1.4 Hdi	WA8HRC, WA8HZC, WC8HRC, WC8HZC	1.4	50	4	01.12-10.13	DV4C	11,0	YE05	91322	73
------------------	---	-----	----	---	-------------	------	------	------	-------	----

207 SW

207 SW 1.6 Hdi	WK9HXC	1.6	66	4	08.07-12.12	DV6ATED4	11,0	YE05	91322	73
207 SW 1.6 Hdi	WK9HP0	1.6	68	4	11.09-12.12	DV6DTED	5,0	Y8001AS	8904	58
207 SW 1.6 Hdi	WK9HR8	1.6	82	4	12.09-10.13	DV6C	5,0	Y8001AS	8904	58

208

208 1.4 Hdi 68		1.4	50	4	03.12-	DV4C	11,0	YE05	91322	73
208 1.6 BlueHdi/Hdi	CABHW6, CC9H0C, CCBHW6	1.6	55	4	01.13-	DV6ETEDM	5,0	Y8001AS	8904	58
208 1.6 Hdi 92		1.6	68	4	03.12-	DV6DTED	5,0	Y8001AS	8904	58
208 1.6 e-Hdi	CA9HP8, CA9HPK, CC9HP8, CC9HPK	1.6	68	4	03.12-	DV6DTEDM	5,0	Y8001AS	8904	58





l kW C
Y I



Stock-No
D-POWER

PEUGEOT

208

208 1.6 HDi 115	1.6	84	4	03.12-	DV6C	5,0	Y8001AS	8904	58
-----------------	-----	----	---	--------	------	-----	---------	------	----

3008

3008 1.6 HDi	1.6	80	4	05.09-	DV6TED4	11,0	YE05	91322	73
3008 1.6 HdI 110	1.6	82	4	08.10-	DV6CTED4~9HZ	5,0	Y8001AS	8904	58
3008 1.6 HDi 115	1.6	84	4	03.13-	DV6C	5,0	Y8001AS	8904	58
3008 HdI	2.0	80	4	06.09-	DW10CTED4	5,0	Y8001AS	8904	58
3008 2.0 HdI	2.0	100	4	02.11-	DW10CB	5,0	Y8001AS	8904	58
3008 2.0 HdI 150	2.0	110	4	04.09-	DW10CTED4, RHE, RHH	5,0	Y8001AS	8904	58
3008 2.0 BlueHDi/HDi	2.0	110	4	06.09-	DW10FD	5,0	Y8001AS	8904	58
					OUAHOM, OURHEM, OURHET				
3008 2.0 HDi 165	2.0	120	4	06.09-	DW10CTED4	5,0	Y8001AS	8904	58
3008 2.0 HDi Hybrid4	2.0	120	4	09.11-	DW10CTED4	5,0	Y8001AS	8904	58

301

301 1.6 HDi 92	1.6	68	4	10.12-	DV6DTE4	5,0	Y8001AS	8904	58
----------------	-----	----	---	--------	---------	-----	---------	------	----

306

306	1.8	43	4	10.93-08.98	XUD7	11,0	Y-924J	7906	1
306 D	1.8	44	4	09.98-07.02	DW8	11,0	Y-503J	1009	10
306	1.8	44	4	09.98-	XUD7	11,0	Y-924J	7906	1
306 TD	1.8	59	4	09.98-07.02	DW8TD	11,0	Y-503J	1009	10
306 D	1.9	51	4	02.93-08.98	XUD9A	11,0	Y-924J	7906	1
306	1.9	51	4	09.98-07.02	DW8	11,0	Y-503J	1009	10
306	1.9	51	4	09.98-12.99	XUD9A, XUD9BSD	11,0	Y-924J	7906	1
306 D	1.9	68	4	03.93-08.98	XUD9TE	11,0	Y-924J	7906	1
306 D	1.9	68	4	09.98-12.99	XUD9TE	11,0	Y-924J	7906	1
306 2.0 HDi	2.0	66	4	08.98-06.00	DW10TD	11,0	Y-504J	1441	24
306 HdI	2.0	66	4	04.99-07.02	DW10TD	11,0	Y-504J	1441	24
306 D	2.0	80	4	09.98-	DW10TD	11,0	Y-504J	1441	24

307

307 & SW HdI	1.4	51	4	01.02-12.04	DV4TD	11,0	YE04	1684	40
307 HdI	1.4	51	4	01.02-12.04	DV4TD	11,0	YE04	1684	40
307 & SW	1.4	51	4	12.04-05.05	DV4TD	11,0	YE05	91322	73
307 1.6 HdI	1.6	66	4	04.05-	DV6ATED4	11,0	YE05	91322	73
307 & SW HdI	1.6	68	4	07.06-	DV6TD	11,0	YE04	1684	40
307 & SW HdI	1.6	81	4	03.04-06.06	DV6TED4	11,0	YE04	1684	40
307 & SW HdI	1.6	81	4	07.06-		11,0	YE05	91322	73
307 & SW HdI	1.6	81	4	07.06-	DV6	11,0	YE05	91322	73
307 & SW HdI	2.0	66	4	04.01-	DW10TD	11,0	Y-504J	1441	24
307 2.0 HDi	2.0	66	4	04.03-04.08	DW10TD	11,0	Y-504J	1441	24
307 2.0 HDi	2.0	79	4	01.03-12.09	DW10ATED	11,0	Y-504J	1441	24
307 & SW HdI	2.0	81	4	09.01-	DW10ATED	11,0	Y-504J	1441	24
307 2.0 HdI	2.0	100	4	11.03-11.07	DW10BTED4	11,0	Y1005J	7957	56
307 & SW HdI	2.0	100	4	03.04-	DW10TED	11,0	Y-504J	1441	24

307 CC

307 CC 2.0 HdI	2.0	100	4	11.03-04.09	DW10BTED4	11,0	Y1005J	7957	56
----------------	-----	-----	---	-------------	-----------	------	--------	------	----





e kW C
y i



Stock-No
D-POWER

PEUGEOT

307 SW

307 SW 1.6 HDi	3E9H02B, 3E9HXB	1.6	66	4	04.05-04.08	DV6ATED4	11,0	YE05	91322	73
307 SW 1.6 HDi	3H9HVC	1.6	66	4	04.06-10.08	DV6ATED4	11,0	YE05	91322	73
307 SW 2.0 HDi	3ERHYB, 3HRHYB	2.0	66	4	03.02-04.08	DW10TD	11,0	Y-504J	1441	24
307 SW 2.0 HDi	3ERHYB	2.0	66	4	04.03-04.08	DW10TD	11,0	Y-504J	1441	24
307 SW 2.0 HDi		2.0	100	4	11.03-04.08	DW10BTED4	11,0	Y1005J	7957	56

308

308 1.6 HDi	4A9HXC, 4C9HXC	1.6	66	4	09.07-10.14	DV6ATED4	11,0	YE05	91322	73
308 1.6 e-HDi/HDi	4A9HR8, 4C9HR8	1.6	82	4	02.09-10.14	DV6CM	5,0	Y8001AS	8904	58
308 2.0 BlueHdi	LHAHXH, LHAHXW	2.0	110	4	11.13-	DW10FD	5,0	Y8001AS	8904	58

308 CC I

308 CC I 1.6 Hdi 115		1.6	84	4	03.13-	DV6C	5,0	Y8001AS	8904	58
308 CC I 2.0 Hdi 165		2.0	120	4	06.09-	DW10CTED4	5,0	Y8001AS	8904	58

308 I

308 I 1.6 Hdi		1.6	66	4	09.07-	DV6TD	11,0	YE05	91322	73
308 I 1.6 Hdi		1.6	68	4	11.09-	DV6DTEd	5,0	Y8001AS	8904	58
308 I 1.6 Hdi		1.6	80	4	09.07-	DV6TED4	11,0	YE05	91322	73
308 I 1.6 Hdi 110		1.6	82	4	12.09-	DV6CTED4	5,0	Y8001AS	8904	58
308 I 2.0 Hdi		2.0	100	4	09.07-	DW10BTED	11,0	Y1005J	7957	56
308 I 2.0 Hdi		2.0	100	4	09.07-	DW10BTED4	11,0	Y1005J	7957	56
308 I 2.0 Hdi 140		2.0	103	4	07.10-	DW10BTED	11,0	Y1005J	7957	56
308 I 2.0 Hdi 150		2.0	110	4	10.11-	DW10CTED4	5,0	Y8001AS	8904	58
308 I 2.0 Hdi 165		2.0	120	4	07.09-	DW10CTED4	5,0	Y8001AS	8904	58

308 II

308 II 1.6 HDi 92		1.6	68	4	09.13-	DV6DTEd	5,0	Y8001AS	8904	58
308 II 1.6 HDi 115		1.6	84	4	03.13-	DV6C	5,0	Y8001AS	8904	58
308 II 1.6 e-HDi 115		1.6	85	4	09.13-	DV6C	5,0	Y8001AS	8904	58

309

309		1.5	42	4	03.94-12.95	TUD5	11,0	Y-503J	1009	10
309 D		1.8	44	4	06.86-12.93	XUD7	11,0	Y-924J	7906	1
309 TD		1.8	58	4	11.89-12.93	XUD7T	11,0	Y-924J	7906	1
309 D		1.9	47	4	06.86-12.93	XUD9, XUD9Y	11,0	Y-924J	7906	1

4007

4007 2.2 Hdi		2.2	115	4	07.07-	DW12MTED4	11,0	YE08	4966	
--------------	--	-----	-----	---	--------	-----------	------	------	------	--

4008

4008 1.6 Hdi 115		1.6	84	4	04.12-	DV6C	5,0	Y8001AS	8904	58
------------------	--	-----	----	---	--------	------	-----	---------	------	----

405

405 TD		1.8	68	4	03.88-12.92	XUD7TE	11,0	Y-924J	7906	1
405 GLD		1.9	47	4	07.88-12.92	XUD9Y	11,0	Y-924J	7906	1
405 D		1.9	51	4	03.88-	XUD9A	11,0	Y-924J	7906	1
405		1.9	51	4	09.98-12.99	XUD9A	11,0	Y-924J	7906	1
405		1.9	55	4	10.95-	XUD9SD	11,0	Y-924J	7906	1
405 TD		1.9	68	4	09.92-12.97	XUD9TE, XUD9TF	11,0	Y-924J	7906	1

406

406 TD		1.9	68	4	10.95-08.98	XUD9TE, TF, BTF	11,0	Y-924J	7906	1
--------	--	-----	----	---	-------------	-----------------	------	--------	------	---





l kW C
Y I



Stock-No
D-POWER

PEUGEOT

406

406	1.9	68	4	09.98-12.99	XUD9TE, TF, BTF	11,0	Y-924J	7906	1
406 Hdi	2.0	81	4	12.98-04.04	DW10ATED	11,0	Y-504J	1441	24
406 TD	2.1	80	4	10.95-08.98	XUD11BTE	11,0	Y-924J	7906	1
406	2.1	80	4	09.98-12.99	XUD11BTE	11,0	Y-924J	7906	1
406 2.2 Hdi	2.2	98	4	03.00-10.04	DW12TED4	11,0	Y1005J	7957	56
406 2.2 HDi	2.2	98	4	03.00-05.04	DW12TED4	11,0	Y-504J	1441	24
406 Coupe 2.2 Hdi	2.2	98	4	09.00-12.04	DW12TED4	11,0	Y1005J	7957	56
406 Coupe Hdi	2.2	100	4	03.01-	DW12TED4	11,0	Y-504J	1441	24

406 PHASE 2

406 TD Phase 2	2.0	66	4	04.99-04.04	DW10TD	11,0	Y-504J	1441	24
406 TD Phase 2	2.0	81	4	04.99-04.04	DW10ATED	11,0	Y-504J	1441	24
406 Hdi Phase 2	2.2	100	4	09.00-05.03	DW12TED4	11,0	Y-504J	1441	24

407

407 1.6 Hdi	1.6	81	4	04.04-06.06	DV6TED	11,0	YE04	1684	40
407 1.6 Hdi	1.6	81	4	03.06-12.10	DV6TED4	11,0	YE05	91322	73
407 2.0 Hdi	2.0	93	4	04.04-12.10	DW10TED	11,0	Y-504J	1441	24
407 2.0 Hdi	2.0	100	4	08.05-05.09	DW10BTED4	11,0	Y1005J	7957	56
407 2.0 HDi	2.0	120	4	06.09-12.10	DW10CTED4	5,0	Y8001AS	8904	58
407 2.2 HDi	2.2	120	4	03.06-12.10	DW12BTED4	11,0	YE08	4966	
407 2.2 HDi	2.2	125	4	03.06-12.10	DW12BTED4	11,0	YE08	4966	
407 2.2 Hdi	2.2	125	4	05.06-12.10	DW12BTED4	11,0	YE08	4966	
407 2.7 V6 Hdi	2.7	150	6	10.05-12.10	DT17TED4	11,0	YE12	7794	

408

408 2.0 Hdi	2.0	110	4	.10-	DW10CTED4	5,0	Y8001AS	8904	58
-------------	-----	-----	---	------	-----------	-----	---------	------	----

5008

5008 1.6 Hdi 110	1.6	80	4	09.09-	DV6TED4	5,0	Y8001AS	8904	58
5008 1.6 HDi 110	1.6	82	4	08.10-	DV6C	5,0	Y8001AS	8904	58
5008 1.6 HDi 115	1.6	84	4	03.13-	DV6C	5,0	Y8001AS	8904	58
5008 2.0 HDi	2.0	100	4	09.09-	DW10CB	5,0	Y8001AS	8904	58
5008 2.0 HDi	2.0	100	4	09.09-	DW10FD	5,0	Y8001AS	8904	58
5008 2.0 HDi 140	2.0	100	4	02.12-	DW10CTED4	5,0	Y8001AS	8904	58
5008 2.0 BlueHdi/HDi	2.0	110	4	06.09-	DW10FD	5,0	Y8001AS	8904	58
5008 2.0 Hdi 150	2.0	110	4	09.09-	DW10CTED4	5,0	Y8001AS	8904	58
5008 2.0 Hdi 165	2.0	121	4	09.09-	DW10CTED4	5,0	Y8001AS	8904	58

508

508 1.6 Hdi 110	1.6	82	4	11.10-	DV6C	5,0	Y8001AS	8904	58
508 1.6 Hdi 110	1.6	84	4	02.12-	DV6C	5,0	Y8001AS	8904	58
508 1.6 e-Hdi 115	1.6	84	4	03.13-	DV6C	5,0	Y8001AS	8904	58
508 2.0 Hdi 140	2.0	103	4	11.10-	DW10BTED4	11,0	Y1005J	7957	56
508 2.0 BlueHdi	2.0	110	4	04.14-	DW10FD	5,0	Y8001AS	8904	58





e kW C
y
i



Stock-No
D-POWER

PEUGEOT

508

508 2.0 Hdi 165	2.0	120	4	11.10-	DW10CTED4	5,0	Y8001AS	8904	58
508 2.0 Hdi RXH HYbrid4	2.0	120	4	12.11-	DW10CTED4	5,0	Y8001AS	8904	58

605

605 D	2.1	60	4	09.89-06.94	XUD11A, L	11,0	Y-924J	7906	1
605 TD	2.1	80	4	09.89-06.94	XUD11ATE, L, BTE	11,0	Y-924J	7906	1
605 TD	2.1	80	4	09.98-07.00	XUD11ATE, BTE	11,0	Y-924J	7906	1
605 TD	2.5	96	4	07.94-05.99	DK5ATE	11,0	Y-924J	7906	1

607

607 2.0 Hdi	2.0	100	4	09.05-	DW10BTED4	11,0	Y1005J	7957	56
607 2.2 Hdi	2.2	98	4	12.99-02.06	DW12TED4	11,0	Y1005J	7957	56
607 2.2 HDi	2.2	98	4	12.99-02.06	DW12TED4	11,0	Y-504J	1441	24
607 2.2 Hdi 16V	2.2	100	4	05.00-	DW12TED4	11,0	Y-504J	1441	24
607 2.2 Hdi	2.2	125	4	06.06-	DW12BTED4	11,0	YE08	4966	
607 2.7 V6 Hdi	2.7	150	6	12.04-	DT17TED4	11,0	YE12	7794	

806

806 TD	1.9	68	4	06.94-08.98	XUD9TE	11,0	Y-924J	7906	1
806 D	1.9	68	4	09.98-	XUD9BTF	11,0	Y-924J	7906	1
806 D	1.9	68	4	09.98-01.01	XUD9TE	11,0	Y-924J	7906	1
806 D	2.0	80	4	09.98-	DW10TED	11,0	Y-504J	1441	24
806 2.0 HDi	2.0	80	4	08.99-08.02	DW10ATED4	11,0	Y1005J	7957	56
806 D Hdi	2.0	81	4	09.99-	DW10ATED	11,0	Y-504J	1441	24
806 D	2.1	80	4	06.96-08.98	XUD11BTE	11,0	Y-924J	7906	1
806 TD	2.1	80	4	07.96-	XUD11ATE	11,0	Y-924J	7906	1
806 D	2.1	80	4	09.98-01.01	XUD11BTE	11,0	Y-924J	7906	1

807

807 2.0 HDi	2.0	79	4	06.02-05.06	DW10ATED4	11,0	Y-504J	1441	24
807 2.0 Hdi	2.0	79	4	08.02-05.06	DW10ATED4	11,0	Y1005J	7957	56
807 Hdi	2.0	80	4	06.02-	DW10ATED4, RHT	11,0	Y-504J	1441	24
807 2.0 Hdi	2.0	80	4	04.04-05.06	DW10ATED4	11,0	Y1005J	7957	56
807 2.0 HDi	2.0	80	4	04.04-05.06	DW10ATED4	11,0	Y-504J	1441	24
807 2.0 Hdi	2.0	88	4	11.06-	DW10UTED4	11,0	Y1005J	7957	56
807 2.0 Hdi	2.0	100	4	06.06-	DW10BTED4	11,0	Y1005J	7957	56
807 2.0 Hdi	2.0	120	4	06.09-	DW10CTED4	5,0	Y8001AS	8904	58
807 Hdi	2.2	94	4	06.02-	DW12TED4, 4HW	11,0	Y-504J	1441	24
807 2.2 Hdi	2.2	94	4	08.02-05.06	DW12TED4	11,0	Y1005J	7957	56
807 2.2 HDi	2.2	100	4	04.04-05.06	DW12TED4	11,0	Y-504J	1441	24
807 2.2 Hdi	2.2	125	4	06.06-	DW12BTED4	11,0	YE08	4966	

BIPPER

Bipper 1.3 HDi 75	1.3	55	4	10.10-	F13DTE5	4,3	Y9001AS	97719	72
-------------------	-----	----	---	--------	---------	-----	---------	-------	----





l kW C
y I



Stock-No
D-POWER

PEUGEOT

BIPPER

Bipper Tepee 1.3 HDi 75	1.3	55	4	10.10-	F13DT	4,3	Y9001AS	97719	72
Bipper 1.4 Hdi	1.4	50	4	02.08-	DV4TED	11,0	YE05	91322	73

BOXER

Boxer D	1.8	44	4	09.98-	XUD7	11,0	Y-924J	7906	1	
Boxer D	1.9	51	4	03.94-08.98	XUD9A	11,0	Y-924J	7906	1	
Boxer D	1.9	51	4	09.98-	XUD9AU	11,0	Y-924J	7906	1	
Boxer TD	1.9	68	4	03.94-08.98	XUD9TE	11,0	Y-924J	7906	1	
Boxer	1.9	68	4	09.98-	XUD9TE	11,0	Y-924J	7906	1	
Boxer 2.2 Hdi	2.2	74	4	12.01-06.06	DW12UTED	11,0	Y1005J	7957	56	
Boxer 2.2 HDi	Z_4HY	2.2	74	4	12.01-06.06	DW12UTED	11,0	Y-504J	1441	24
Boxer 2.2 Hdi 100	2.2	74	4	04.06-	4HV	11,5	Y-548J	94832	75	
Boxer 2.2 Hdi 120	2.2	88	4	04.06-	4HU	11,5	Y-548J	94832	75	
Boxer	2.5	63	4	03.94-08.98	DJ5	11,0	Y-924J	7906	1	
Boxer TD	2.5	76	4	03.94-08.96	DJ5T	11,0	Y-924J	7906	1	
Boxer Tdi	2.5	76	4	09.96-	DJ5TED	11,0	Y-738U	5390		
Boxer Hdi	2.8	93	4	10.97-	Sofim	11,0	Y-924J	7906	1	
Boxer 3.0 Hdi	3.0	107	4	04.10-	F30DT	11,0	Y8005J	96853	64	
Boxer 3.0 Hdi 160	3.0	116	4	04.06-	F30DT	11,0	Y8005J	96853	64	

BOXER II

Boxer II Hdi	2.0	66	4	09.98-	DW10TD	11,0	Y-504J	1441	24
Boxer II Hdi	2.2	100	4	03.01-	DW10TED4	11,0	Y-504J	1441	24

EXPERT

Expert 1.6 HDi	VF3XA9HUC, VF3XH9HUC, VF3XU9HUC, VF3XV9HU0	1.6	66	4	11.06-	DV6UTED4	11,0	YE05	91322	73
Expert 1.6 Hdi		1.6	66	4	01.07-	DV6UTED4	11,0	YE05	91322	73
Expert 1.6 HDi	VF3XW9HUC	1.6	66	4	06.07-	DV6UTED4	11,0	YE05	91322	73
Expert TD		1.8	59	4	09.98-	DW8TD	11,0	Y-503J	1009	10
Expert		1.9	51	4	01.96-08.98	XUD9A	11,0	Y-924J	7906	1
Expert	BAWJYB, BDWJYB, BTWJZA, BYWJZA	1.9	51	4	06.98-10.06	DW8B	11,0	Y-503J	1009	10
Expert	BTWJYA, BTWJZA, BYWJYA, BYWJZA	1.9	51	4	06.98-11.03	DW8B	11,0	Y-503J	1009	10
Expert	BTWJYB, BTWJZA, BYWJZA, BZWJYB	1.9	51	4	06.98-10.06	DW8B	11,0	Y-503J	1009	10
Expert	BTWJYB, BTWJZA, BYWJZA, BZWJYB	1.9	51	4	06.98-10.06	DW8	11,0	Y-503J	1009	10
Expert		1.9	51	4	09.98-	XUD9A	11,0	Y-924J	7906	1
Expert TD		1.9	66	4	09.95-08.98	XUD 9TE	11,0	Y-924J	7906	1
Expert		1.9	68	4	01.96-08.98	XUD9BTF	11,0	Y-924J	7906	1
Expert		1.9	68	4	01.96-08.98	XUD9TF	11,0	Y-924J	7906	1
Expert TD		1.9	68	4	09.98-	XUD9BTF	11,0	Y-924J	7906	1
Expert TD		1.9	68	4	09.98-	XUD9TF	11,0	Y-924J	7906	1
Expert 2.0 HDi	B_RHX	2.0	69	4	10.00-10.06	DW10BTED	11,0	Y-504J	1441	24





e kW C
y i



Stock-No
D-POWER

PEUGEOT

EXPERT

Expert Hdi		2.0	70	4	02.00-	DW10TED	11,0	Y-504J	1441	24
Expert 2.0 Hdi 100		2.0	72	4	03.11-	DW10CE	5,0	Y8001AS	8904	58
Expert 2.0 HDi	BARHWB, BDRHWB, BSRHWF, BYRHWF	2.0	80	4	10.00-10.06	DW10ATED4	11,0	Y1005J	7957	56
Expert 2.0 HDi	BTRHWB, BTRHWF, BZRHWB	2.0	80	4	10.00-10.06	DW10ATED4	11,0	Y1005J	7957	56
Expert 2.0 HDi	B_RHW	2.0	80	4	10.00-10.06	DW10ATED4	11,0	Y-504J	1441	24
Expert Hdi		2.0	81	4	02.00-	DW10ATED	11,0	Y-504J	1441	24
Expert Hdi		2.0	88	4	11.06-	DW10UTED4	11,0	Y1005J	7957	56
Expert 2.0 Hdi 130		2.0	94	4	03.11-	DW10CD	5,0	Y8001AS	8904	58
Expert Hdi		2.0	100	4	11.06-	DW10BTED4	11,0	Y1005J	7957	56
Expert 2.0 Hdi 165		2.0	120	4	09.09-	DW10CTED4	5,0	Y8001AS	8904	58
Expert		2.1	80	4	07.96-	XUD11ATE	11,0	Y-924J	7906	1

J5

J5		1.9	51	4	11.87-01.94	XUD9A	11,0	Y-924J	7906	1
J5 D		1.9	51	4	11.87-	XUD9A	11,0	Y-924J	7906	1
J5 D		2.5	54	4	09.81-06.91	CRD93	11,0	Y-208T	1250	
J5		2.5	54	4	07.91-03.94	CRD93	11,0	Y-924J	7906	1
J5 TD		2.5	70	4	07.87-06.91	CRD93LS	11,0	Y-208T	1250	
J5		2.5	70	4	07.91-03.94	CRD93LS	11,0	Y-924J	7906	1

PARTNER

Partner 1.4 Hdi		1.4	55	4	03.06-	DV6	11,0	YE05	91322	73
Partner 1.6 HDi	GB9H0C	1.6	55	4	08.05-07.08	DV6ETEDM	5,0	Y8001AS	8904	58
Partner 1.6 Hdi		1.6	55	4	04.08-	DV6BTED4	11,0	YE05	91322	73
Partner 1.6 BlueHDi/HDi	3A9HN0, 3ABHW6, 3B9H0B, 3B9H0W, 3B9HN0, 3B9HT0, 3BBHW6, 3CBHW6, 3DBHW6, 3E9HN0	1.6	55	4	06.08-	DV6ETED	5,0	Y8001AS	8904	58
Partner 1.6 BlueHDi/HDi	3A9HN0, 3ABHW6, 3B9H0B, 3B9H0W, 3B9HN0, 3B9HT0, 3BBHW6, 3CBHW6, 3DBHW6, 3E9HN0	1.6	55	4	06.08-	DV6ETEDM	5,0	Y8001AS	8904	58
Partner 1.6 HDi	GB9HXC, GC9HXC	1.6	66	4	08.05-12.15	DV6ATED4	11,0	YE05	91322	73
Partner 1.6 Hdi		1.6	66	4	03.06-	DV6	11,0	YE05	91322	73
Partner 1.6 HDi	3J9HT0, 3J9HX0, 3J9HZ0	1.6	66	4	04.08-	DV6ATED4	11,0	YE05	91322	73
Partner 1.6 HDi	GA9HXC	1.6	66	4	08.08-12.13	DV6ATED4	11,0	YE05	91322	73





l kW C
y
i



Stock-No
D-POWER

PEUGEOT

PARTNER

Partner 1.6 e-HDi/HDi	3A9HF0, 3A9HF8, 3B9HF0, 3B9HF8, 3C9HF0, 3C9HF8, 3D9HF0, 3D9HF8, 3E9HF0, 3E9HF8, 3F9HF0, 3F9HF8	1.6	66	4	03.13-	DV6DTEd	5,0	Y8001AS	8904	58
Partner 1.6 HDi	3G9HF0, 3M9HF0	1.6	66	4	03.13-	DV6DTEd	5,0	Y8001AS	8904	58
Partner 1.6 HDi	3J9HF0	1.6	66	4	03.13-	DV6DTEd	5,0	Y8001AS	8904	58
Partner 1.6 HDi	GB9H0C	1.6	68	4	08.05-07.08	DV6DTEdM	5,0	Y8001AS	8904	58
Partner 1.6 e-HDi/HDi	3A9HX0, 3B9HX0, 3D9HX0, 3E9HX0, 3F9HX0, 3N9HX0	1.6	68	4	04.10-	DV6ATEd4	11,0	YE05	91322	73
Partner 1.6 e-HDi/HDi	3A9HX0, 3B9HX0, 3D9HX0, 3E9HX0, 3F9HX0, 3N9HX0	1.6	68	4	04.10-	DV6AUATEd4	11,0	YE05	91322	73
Partner 1.6 e-HDi/HDi	3J9HX0	1.6	68	4	04.10-	DV6ATEd4	11,0	YE05	91322	73
Partner 1.6 e-HDi/HDi	3J9HP0, 3J9HP8	1.6	68	4	05.11-	DV6DTEd	5,0	Y8001AS	8904	58
Partner 1.6 HDi	3B9HP0, 3B9HX0	1.6	68	4	05.11-	DV6DTEd	5,0	Y8001AS	8904	58
Partner 1.6 HDi	3B9HP0, 3B9HX0	1.6	68	4	05.11-	DV6DTEdM	5,0	Y8001AS	8904	58
Partner 1.6 HDi	3G9HX0	1.6	68	4	01.14-	DV6ATEd4	11,0	YE05	91322	73
Partner 1.6 HDi	3G9HX0	1.6	68	4	01.14-	DV6AUATEd4	11,0	YE05	91322	73
Partner 1.6 HDi	3B9HZW	1.6	80	4	04.08-	DV6TEd4	11,0	YE05	91322	73
Partner 1.6 HDi	3J9HR0	1.6	82	4	08.10-	DV6C	5,0	Y8001AS	8904	58
Partner 1.6 HDi	3A9HL0, 3B9HL0, 3B9HR0, 3C9HR0	1.6	84	4	07.12-	DV6C	5,0	Y8001AS	8904	58
Partner 1.6 HDi	3A9HL0, 3B9HL0, 3B9HR0, 3C9HR0	1.6	84	4	07.12-	DV6CTEd	5,0	Y8001AS	8904	58
Partner 1.6 HDi	3J9HD0	1.6	84	4	07.12-	DV6C	5,0	Y8001AS	8904	58
Partner 1.9 HDi	GAWJYB, GBWJYB	1.9	51	4	08.08-12.13	DW8B	11,0	Y-503J	1009	10
Partner 1.9 HDi	GJWJYB	1.9	51	4	08.08-12.13	DW8B	11,0	Y-503J	1009	10

PARTNER COMBI

Partner Combi		1.8	43	4	07.96-08.98	XUD7	11,0	Y-924J	7906	1
Partner Combi		1.8	44	4	09.98-03.02	DW8	11,0	Y-503J	1009	10
Partner Combi		1.8	44	4	09.98-03.02	XUD7	11,0	Y-924J	7906	1
Partner Combi		1.8	59	4	09.98-03.02	DW8TD	11,0	Y-503J	1009	10
Partner Combi		1.9	51	4	07.96-08.98	XUD9A	11,0	Y-924J	7906	1
Partner Combi		1.9	51	4	09.98-03.02	DW8, DW8B	11,0	Y-503J	1009	10
Partner Combi		1.9	51	4	09.98-03.02	XUD9A	11,0	Y-924J	7906	1
Partner Combi Hdi		2.0	66	4	10.99-03.02	DW10TD	11,0	Y-504J	1441	24



e kW C
y
iStock-No
D-POWER™**PEUGEOT****PARTNER MULTISPACE**

Partner Multispace	1.9	51	4	01.97-09.98	XUD9A	11,0	Y-924J	7906	1
Partner Multispace	1.9	51	4	09.98-	DW8, DW8B	11,0	Y-503J	1009	10
Partner Multispace Hdi	2.0	66	4	10.99-	DW10TD	11,0	Y-504J	1441	24

RCZ

RCZ 2.0 Hdi 165	2.0	120	4	03.10-	DW10CTED4	5,0	Y8001AS	8904	58
-----------------	-----	-----	---	--------	-----------	-----	---------	------	----

PORSCHE**CAYENNE I**

Cayenne	955	2.5	128	5	.04-	BAC	11,0	Y-741U	6943	20
Cayenne I 3.0 TDI	955	3.0	176	6	02.09-05.10	M05.9D	4,4	Y1002AS	8888	57

CAYENNE II

Cayenne II 3.0 D	958	3.0	155	6	06.10-	MCR.CB	4,4	Y1002AS	8888	57
Cayenne II 3.0 D	958	3.0	176	6	06.10-	M05.9E, MCN.RB	4,4	Y1002AS	8888	57
Cayenne II 3.0 D	958	3.0	180	6	06.10-	MCR.CA	4,4	Y1002AS	8888	57
Cayenne II 4.2 D S	958	4.2	281	8	10.12-	MCU.DB	4,4	Y1002AS	8888	57

MACAN

Macan 3.0 D	95B	3.0	155	6	02.14-	MCT.BB	4,4	Y1002AS	8888	57
Macan 3.0 D	95B	3.0	184	6	02.14-	MCT.BC	4,4	Y1002AS	8888	57
Macan 3.0 D	95B	3.0	190	6	02.14-	MCT.BA	4,4	Y1002AS	8888	57

PANAMERA

Panamera 3.0 D	970	3.0	155	6	08.11-	MCR.CB	4,4	Y1002AS	8888	57
Panamera 3.0 D	970	3.0	184	6	08.11-	MCR.CC	4,4	Y1002AS	8888	57

RENAULT**ALASKAN**

Alaskan 2.3 dCi (color code: Red)	U3MD, U3MB	2.3	140	4	09.17-	M9T260	4,5	Y1047AS	95340	
-----------------------------------	------------	-----	-----	---	--------	--------	-----	---------	-------	--

AVANTIME

Avantime		2.2	110	4	06.02-05.03	G9T 712	11,0	Y-517J	91766	66
----------	--	-----	-----	---	-------------	---------	------	--------	-------	----

CLIO

Clio 1		1.9	47	4	05.90-02.91		11,0	Y-924J	7906	1
Clio 1		1.9	48	4	05.90-09.98	F8Q714, F8Q730, F8Q732	11,0	Y-913J	5317	15
Clio 1		1.9	48	4	03.91-08.98	F8Q672, F8Q676, F8Q678, F8Q692, F8Q696	11,0	Y-927J	4916	19

CLIO 2

Clio 2		1.9	48	4	03.98-12.03	F8Q 630	11,0	Y-506J	2419	7
Clio 2		1.9	48	4	03.98-12.03	F8Q 662	11,0	Y-506J	2419	7
Clio 2		1.9	48	4	03.99-12.03	F8Q 632	11,0	Y-516J	6416	12
Clio 2 Dti		1.9	59	4	01.99-12.03	F9Q 716	11,0	Y-740U	4818	22
Clio 2 Dti		1.9	59	4	01.99-06.01	F9Q 782	11,0	Y-740U	4818	22
Clio 2 Dti		1.9	59	4	03.99-12.03	F9Q 780	12,0	Y-732J	5605	4

CLIO 2 PHASE 2

Clio 2 Phase 2 1.5 dCi	CB07	1.5	42	4	06.01-12.06	K9K704	12,0	Y-732J	5605	4
Clio 2 Phase 2 1.5 Dci		1.5	48	4	06.01-02.08	K9K 700	12,0	Y-732J	5605	4
Clio 2 Phase 2 1.5 Dci		1.5	48	4	06.01-	K9K 704	12,0	Y-732J	5605	4
Clio 2 Phase 2 1.5 Dci		1.5	48	4	06.01-	K9K 710	12,0	Y-732J	5605	4
Clio 2 Phase 2 1.5 Dci		1.5	50	4	08.04-	K9K 714	12,0	Y-732J	5605	4
Clio 2 Phase 2 1.5 Dci		1.5	59	4	11.01-	K9K 702	12,0	Y-732J	5605	4





e kW C
Y
I



Stock-No
D-POWER

RENAULT

CLIO 2 PHASE 2

Clio 2 Phase 2 1.5 Dci	1.5	60	4	11.03-04.05	K9K702, K9K710, K9K716	12,0	Y-732J	5605	4
Clio 2 Phase 2 1.5 Dci	1.5	62	4	02.07-06.09	K9K 718	12,0	Y-732J	5605	4
Clio 2 Phase 2 1.5 Dci	1.5	74	4	.04-	K9K 712	12,0	Y-732J	5605	4

CLIO 3

Clio 3 1.5 Dci	1.5	47	4	06.05-	K9K 752	12,0	Y-732J	5605	4
Clio 3 1.5 Dci	1.5	48	4	05.05-10.06	K9K 752	12,0	Y-732J	5605	4
Clio 3 1.5 Dci	1.5	50	4	06.05-	K9K 768	12,0	Y-732J	5605	4
Clio 3 1.5 Dci	1.5	55	4	08.10-	K9K 770	4,4	Y1035AS	94103	77
Clio 3 1.5 Dci	1.5	60	4	11.07-	K9K 750	12,0	Y-732J	5605	4
Clio 3 1.5 Dci	1.5	63	4	06.05-	K9K 766	12,0	Y-732J	5605	4
Clio 3 1.5 Dci	1.5	65	4	08.10-	K9K 770	4,4	Y1035AS	94103	77
Clio 3 1.5 Dci	1.5	76	4	06.05-	K9K 772	12,0	Y-732J	5605	4
Clio 3 1.5 Dci	1.5	78	4	06.05-	K9K 764	12,0	Y-732J	5605	4

CLIO 4

Clio 4 1.5 dCi 75	1.5	55	4	10.12-	K9K 612	4,4	Y1035AS	94103	77
Clio 4 1.5 dCi 90	1.5	66	4	10.12-	K9K 608	4,4	Y1035AS	94103	77

ESPACE 2

Espace 2	2.2	85	4	.91-10.96	G8T 714	11,0	Y-740U	4818	22
Espace 2	2.2	85	4	.91-10.96	G8T 716	11,0	Y-740U	4818	22
Espace 2	2.2	85	4	.91-10.96	G8T 760	11,0	Y-740U	4818	22

ESPACE 3

Espace 3 Dci	1.9	74	4	02.99-12.02	F9Q 722	12,0	Y-732J	5605	4
Espace 3 Dti	1.9	74	4	02.99-12.02	F9Q716, F9Q730, F9Q734	11,0	Y-740U	4818	22
Grand Espace Dti	1.9	74	4	01.00-	F9Q730, F9Q734	11,0	Y-740U	4818	22
Espace 3 DT	2.2	81	4	10.96-08.00	G8T 714	11,0	Y-730U	6704	17
Grand Espace DT	2.2	81	4	01.98-08.00	G8T 716	11,0	Y-730U	6704	17
Espace 3 Dci	2.2	85	4	06.00-12.02	G9T 710	11,0	Y-517J	91766	66
Grand Espace Dci 16S	2.2	85	4	06.00-09.02	G9T 710	11,0	Y-517J	91766	66
Espace 3 Dci	2.2	96	4	06.00-12.02		11,0	Y-517J	91766	66
Grand Espace Dci 16S	2.2	96	4	06.00-09.02		11,0	Y-517J	91766	66

ESPACE 4

Espace 4 1.9 dCi	JK0G, JK0U	1.9	85	4	04.03-10.10	F9Q820	12,0	Y-732J	5605	4
Grand Espace 4 1.9 dCi	JK0G, JK0U	1.9	85	4	04.03-10.10	F9Q820	12,0	Y-732J	5605	4
Espace 4 Dci		1.9	86	4	04.03-10.10	F9Q680	12,0	Y-732J	5605	4
Espace 4 1.9 dCi	JK0U, JK1B	1.9	88	4	04.03-01.15	F9Q820	12,0	Y-732J	5605	4
Grand Espace 4 1.9 dCi	JK0U	1.9	88	4	04.03-02.05	F9Q820	12,0	Y-732J	5605	4
Espace 4 2.0 dCi	JK02, JK03	2.0	96	4	02.07-01.15	M9R740	7,0	CZ167	91063	91
Espace 4 2.0 dCi	JK02, JK03	2.0	96	4	02.07-01.15	M9R750	7,0	CZ167	91063	91
Espace 4 2.0 dCi	JK02, JK03	2.0	96	4	02.07-01.15	M9R760	7,0	CZ167	91063	91
Espace 4 2.0 dCi	JK02, JK03	2.0	96	4	02.07-01.15	M9R761	7,0	CZ167	91063	91
Espace 4 2.0 dCi	JK02, JK03	2.0	96	4	02.07-01.15	M9R762	7,0	CZ167	91063	91
Espace 4 2.0 dCi	JK02, JK03	2.0	96	4	02.07-01.15	M9R763	7,0	CZ167	91063	91
Grand Espace 4 2.0 dCi	JK02	2.0	96	4	05.07-12.15	M9R740	7,0	CZ167	91063	91
Grand Espace 4 2.0 dCi	JK02	2.0	96	4	05.07-12.15	M9R750	7,0	CZ167	91063	91





e kW C y i



Stock-No
D-POWER

RENAULT

ESPACE 4

Espace 4 2.0 dCi	JK01, JK02, JK04, JK1H, JK1J, JK1K	2.0	110	4	02.07-01.15	M9R740	7,0	CZ167	91063	91
Espace 4 2.0 dCi	JK01, JK02, JK04, JK1H, JK1J, JK1K	2.0	110	4	02.07-01.15	M9R750	7,0	CZ167	91063	91
Espace 4 2.0 dCi	JK01, JK02, JK04, JK1H, JK1J, JK1K	2.0	110	4	02.07-01.15	M9R760	7,0	CZ167	91063	91
Espace 4 2.0 dCi	JK01, JK02, JK04, JK1H, JK1J, JK1K	2.0	110	4	02.07-01.15	M9R814	7,0	CZ167	91063	91
Espace 4 2.0 dCi	JK01, JK02, JK04, JK1H, JK1J, JK1K	2.0	110	4	02.07-01.15	M9R815	7,0	CZ167	91063	91
Espace 4 2.0 dCi	JK01, JK02, JK04, JK1H, JK1J, JK1K	2.0	110	4	02.07-01.15	M9R858	7,0	CZ167	91063	91
Grand Espace 4 2.0 dCi	JK01, JK02, JK04, JK1H, JK1J, JK1K	2.0	110	4	02.07-12.15	M9R740	7,0	CZ167	91063	91
Grand Espace 4 2.0 dCi	JK01, JK02, JK04, JK1H, JK1J, JK1K	2.0	110	4	02.07-12.15	M9R750	7,0	CZ167	91063	91
Grand Espace 4 2.0 dCi	JK01, JK02, JK04, JK1H, JK1J, JK1K	2.0	110	4	02.07-12.15	M9R760	7,0	CZ167	91063	91
Grand Espace 4 2.0 dCi	JK01, JK02, JK04, JK1H, JK1J, JK1K	2.0	110	4	02.07-12.15	M9R814	7,0	CZ167	91063	91
Grand Espace 4 2.0 dCi	JK01, JK02, JK04, JK1H, JK1J, JK1K	2.0	110	4	02.07-12.15	M9R815	7,0	CZ167	91063	91
Grand Espace 4 2.0 dCi	JK01, JK02, JK04, JK1H, JK1J, JK1K	2.0	110	4	02.07-12.15	M9R858	7,0	CZ167	91063	91
Espace 4 2.0 dCi	JK03, JK04, JK1C, JK1G, JK1J, JK1K	2.0	127	4	02.07-01.15	M9R760	7,0	CZ167	91063	91
Espace 4 2.0 dCi	JK03, JK04, JK1C, JK1G, JK1J, JK1K	2.0	127	4	02.07-01.15	M9R761	7,0	CZ167	91063	91
Espace 4 2.0 dCi	JK03, JK04, JK1C, JK1G, JK1J, JK1K	2.0	127	4	02.07-01.15	M9R762	7,0	CZ167	91063	91
Espace 4 2.0 dCi	JK03, JK04, JK1C, JK1G, JK1J, JK1K	2.0	127	4	02.07-01.15	M9R763	7,0	CZ167	91063	91
Espace 4 2.0 dCi	JK03, JK04, JK1C, JK1G, JK1J, JK1K	2.0	127	4	02.07-01.15	M9R812	7,0	CZ167	91063	91
Espace 4 2.0 dCi	JK03, JK04, JK1C, JK1G, JK1J, JK1K	2.0	127	4	02.07-01.15	M9R815	7,0	CZ167	91063	91
Espace 4 2.0 dCi	JK03, JK04, JK1C, JK1G, JK1J, JK1K	2.0	127	4	02.07-01.15	M9R859	7,0	CZ167	91063	91
Grand Espace 4 2.0 dCi	JK03, JK04, JK1C, JK1G, JK1J, JK1K	2.0	127	4	02.07-12.15	M9R760	7,0	CZ167	91063	91
Grand Espace 4 2.0 dCi	JK03, JK04, JK1C, JK1G, JK1J, JK1K	2.0	127	4	02.07-12.15	M9R761	7,0	CZ167	91063	91
Grand Espace 4 2.0 dCi	JK03, JK04, JK1C, JK1G, JK1J, JK1K	2.0	127	4	02.07-12.15	M9R762	7,0	CZ167	91063	91
Grand Espace 4 2.0 dCi	JK03, JK04, JK1C, JK1G, JK1J, JK1K	2.0	127	4	02.07-12.15	M9R763	7,0	CZ167	91063	91





e kW C
Y
I



Stock-No
D-POWER

RENAULT

ESPACE 4

Grand Espace 4 2.0 dCi	JK03, JK04, JK1C, JK1G, JK1J, JK1K	2.0	127	4	02.07-12.15	M9R812	7,0	CZ167	91063	91
Grand Espace 4 2.0 dCi	JK03, JK04, JK1C, JK1G, JK1J, JK1K	2.0	127	4	02.07-12.15	M9R859	7,0	CZ167	91063	91
Espace 4 Dci		2.2	110	4	.03-	G9T742	11,0	Y-517J	91766	66
Grand Espace Dci		2.2	110	4	.03-	G9T743	11,0	Y-517J	91766	66
Espace 4 3.0 dCi	JK0J, JK0V, JK0Y	3.0	120	6	11.02-01.15	P9X701	11,0	CZ24	92070	
Espace 4 3.0 dCi	JK0J, JK0V, JK0Y	3.0	120	6	11.02-01.15	P9X715	11,0	CZ24	92070	
Espace 4 3.0 dCi	JK0J, JK0V	3.0	130	6	11.02-08.06	P9X701	11,0	CZ24	92070	
Grand Espace 3.0 dCi	JK0J, JK0V	3.0	130	6	11.02-08.06	P9X701	11,0	CZ24	92070	
Espace 4 3.0 dCi	JK0E	3.0	133	6	01.06-01.15	P9X715	11,0	CZ24	92070	
Grand Espace 3.0 dCi	JK0E	3.0	133	6	04.06-12.15	P9X715	11,0	CZ24	92070	

ESPACE 5

Espace 5 2.0 dCi	JRAM	2.0	118	4	10.18-	M9R650	4,5	Y1047AS	95340	
Espace 5 2.0 dCi	JRAL	2.0	147	4	10.18-	M9R650	4,5	Y1047AS	95340	

ESPACE PHASE IV

Espace 2.0 dCi (color code: Yellow)	JK01, JK02, JK04, JK1H, JK1J, JK1K	2.0	110	4	03.06-01.15	M9R858	4,5	Y1010AS	91210	88
-------------------------------------	------------------------------------	-----	-----	---	-------------	--------	-----	---------	-------	----

EXPRESS

Express		1.6	40	4	07.86-03.98	F8M720, F8M730, F8M736, F8M760	11,0	Y-913J	5317	15
Express		1.9	48	4	09.91-03.98	F8Q 684	11,0	Y-913J	5317	15
Express		1.9	48	4	09.91-03.98	F8Q 722	11,0	Y-913J	5317	15
Express		1.9	48	4	09.91-03.98	F8Q 724	11,0	Y-913J	5317	15
Express		1.9	48	4	09.91-03.98	F8Q 774	11,0	Y-913J	5317	15
Express		1.9	48	4	09.91-03.98	F8Q 776	11,0	Y-913J	5317	15
Express		1.9	48	4	09.94-11.98	F8Q 640	11,0	Y-927J	4916	19
Express		1.9	48	4	09.94-03.98	F8Q 644	11,0	Y-927J	4916	19
Express		1.9	48	4	09.94-03.98	F8Q 646	11,0	Y-927J	4916	19
Express		1.9	48	4	09.94-03.98	F8Q 648	11,0	Y-927J	4916	19
Express		1.9	48	4	07.95-11.98	F8Q 680	11,0	Y-927J	4916	19
Express		1.9	48	4	07.95-03.98	F8Q 682	11,0	Y-927J	4916	19

FLUENCE

Fluence 1.5 dCi		1.5	63	4	02.10-	K9K 830	4,4	Y1035AS	94103	77
Fluence 1.5 dCi		1.5	66	4	02.10-	K9K 834	4,4	Y1035AS	94103	77
Fluence 1.5 dCi		1.5	78	4	02.10-	K9K 832	4,4	Y1035AS	94103	77
Fluence 1.5 dCi		1.5	81	4	02.10-	K9K 836	4,4	Y1035AS	94103	77

FLUENCE DCI

Fluence 1.6 dCi	L339	1.6	96	4	06.13-	R9M402	4,5	Y1010AS	97618	88
-----------------	------	-----	----	---	--------	--------	-----	---------	-------	----

GRAND SCENIC PHASE IV

Grand Scenic 1.6 dCi (color code: Yellow)	R9A4	1.6	96	4	09.16-	R9M409	4,5	Y1010AS	91210	88
Grand Scenic 1.6 dCi (color code: Yellow)	R9A5	1.6	118	4	09.16-	R9M452	4,5	Y1010AS	91210	88

KADJAR

Kadjar 1.7 Blue dCi 150	HLA7	1.7	110	4	08.18-	R9N401	4,5	Y1047AS	95340	
-------------------------	------	-----	-----	---	--------	--------	-----	---------	-------	--





e kW C
y i



Stock-No
D-POWER™

RENAULT

KANGOO

Kangoo 1.5 Dci		1.5	42	4	12.02-	K9K 704		12,0	Y-732J	5605	4
Kangoo 1.5 dCi	KC07	1.5	45	4	04.05-06.10	K9K700		12,0	Y-732J	5605	4
Kangoo 1.5 dCi	KC07	1.5	45	4	04.05-06.10	K9K702		12,0	Y-732J	5605	4
Kangoo 1.5 Dci		1.5	48	4	06.01-	K9K 700		12,0	Y-732J	5605	4
Kangoo 1.5 Dci		1.5	48	4	06.01-	K9K 704		12,0	Y-732J	5605	4
Kangoo 1.5 Dci		1.5	50	4	06.05-	K9K 714		12,0	Y-732J	5605	4
Kangoo 1.5 Dci		1.5	50	4	02.08-	K9K 840		12,0	Y-732J	5605	4
Kangoo 1.5 Dci		1.5	60	4	07.02-	K9K 702		12,0	Y-732J	5605	4
Kangoo 1.5 Dci		1.5	60	4	07.02-	K9K 710		12,0	Y-732J	5605	4
Kangoo 1.5 Dci		1.5	62	4	06.05-	K9K 718		12,0	Y-732J	5605	4
Kangoo 1.5 Dci		1.5	63	4	02.08-	K9K800, K9K802		12,0	Y-732J	5605	4
Kangoo 1.5 dCi	KW0F	1.5	76	4	02.08-	K9K806		12,0	Y-732J	5605	4
Kangoo Express 1.5 dCi	FW0F	1.5	76	4	02.08-	K9K806		12,0	Y-732J	5605	4
Kangoo Rapid 1.5 dCi	FW0F	1.5	76	4	02.08-	K9K806		12,0	Y-732J	5605	4
Kangoo Be Bop 1.5 dCi	KW0F	1.5	76	4	02.09-12.12	K9K806		12,0	Y-732J	5605	4
Kangoo 1.5 dCi	KW0C	1.5	78	4	02.08-	K9K804		12,0	Y-732J	5605	4
Kangoo 1.5 dCi	KW0C	1.5	80	4	10.07-	K9K804		12,0	Y-732J	5605	4
Kangoo Be Bop 1.5 dCi	KW0C	1.5	80	4	06.09-12.12	K9K804		12,0	Y-732J	5605	4
Kangoo Express 1.5 dCi	FW0C	1.5	80	4	09.10-	K9K804		12,0	Y-732J	5605	4
Kangoo Rapid 1.5 dCi	FW0C	1.5	80	4	09.10-	K9K804		12,0	Y-732J	5605	4
Kangoo Express D		1.9	40	4	03.98-	F8Q 662		11,0	Y-506J	2419	7
Kangoo Express D		1.9	48	4	03.98-	F8Q 630		11,0	Y-506J	2419	7
Kangoo Express D		1.9	48	4	03.99-	F8Q 632		11,0	Y-516J	6416	12
Kangoo Dti		1.9	59	4	03.98-	F9Q 780		12,0	Y-732J	5605	4
Kangoo Rapid 1.9 dCi/DTi	FC0U, FC0V	1.9	59	4	09.99-06.08	F9Q790		12,0	Y-732J	5605	4
Kangoo Express 1.9 dCi	FC0V	1.9	59	4	10.01-06.03	F9Q790		12,0	Y-732J	5605	4
Kangoo Dci 4X4		1.9	59	4	11.01-			12,0	Y-732J	5605	4
Kangoo 1.9 dCi	KC0V	1.9	59	4	11.01-06.03	F9Q790		12,0	Y-732J	5605	4
Kangoo Express 1.9 dCi	FC0V	1.9	62	4	07.03-06.08	F9Q790		12,0	Y-732J	5605	4
Kangoo Rapid 1.9 dCi	FC0V	1.9	62	4	07.03-06.08	F9Q790		12,0	Y-732J	5605	4
Kangoo 1.9 dCi	KC0V	1.9	62	4	10.03-09.07	F9Q790		12,0	Y-732J	5605	4

KANGOO EXPRESS

Kangoo Express Dci		1.5	48	4	07.03-	K9K		12,0	Y-732J	5605	4
Kangoo Express Dci		1.5	59	4	.04-	K9K		12,0	Y-732J	5605	4
Kangoo Express Dci		1.9	62	4	.04-	F9Q		12,0	Y-732J	5605	4

KOLEOS

Koleos 1.6 dCi (color code: Yellow)	HCA4	1.6	96	4	08.16-	R9M409		4,5	Y1010AS	91210	88
Koleos 1.7 Blue dCi 150	HCA7	1.7	110	4	06.19-	R9N401		4,5	Y1047AS	95340	
Koleos 2.0 dCi	HY0A, HY0F, HY0G, HY0H, HY0J, HY0K, HY0L, HY0V	2.0	110	4	06.08-	M9R855		7,0	CZ167	91063	91
Koleos 2.0 dCi	HY0A, HY0F, HY0G, HY0H, HY0J, HY0K, HY0L, HY0V	2.0	110	4	06.08-	M9R856		7,0	CZ167	91063	91
Koleos 2.0 dCi	HY0A, HY0F, HY0G, HY0H, HY0J, HY0K, HY0L, HY0V	2.0	110	4	06.08-	M9R862		7,0	CZ167	91063	91





e kW C
y
i



Stock-No
D-POWER

RENAULT

KOLEOS

Koleos 2.0 dCi	HY0A, HY0F, HY0G, HY0H, HY0J, HY0K, HY0L, HY0V	2.0	110	4	06.08-	M9R865	7,0	CZ167	91063	91
Koleos 2.0 dCi	HY0A, HY0F, HY0G, HY0H, HY0J, HY0K, HY0L, HY0V	2.0	110	4	06.08-	M9R866	7,0	CZ167	91063	91
Koleos 2.0 dCi	HY0A, HY0F, HY0G, HY0H, HY0J, HY0K, HY0L, HY0V	2.0	110	4	09.08-	M9R832	7,0	CZ167	91063	91
Koleos 2.0 dCi	HY0A, HY0F, HY0G, HY0H, HY0J, HY0K, HY0L, HY0V	2.0	110	4	09.08-	M9R833	7,0	CZ167	91063	91
Koleos 2.0 dCi	HY0A, HY0F, HY0G, HY0H, HY0J, HY0K, HY0L, HY0V	2.0	110	4	09.08-	M9R834	7,0	CZ167	91063	91
Koleos 2.0 dCi	HY0A, HY0F, HY0G, HY0H, HY0J, HY0K, HY0L, HY0V	2.0	110	4	09.08-	M9R835	7,0	CZ167	91063	91
Koleos 2.0 dCi	HY0A, HY0F, HY0G, HY0H, HY0J, HY0K, HY0L, HY0V	2.0	110	4	09.08-	M9R836	7,0	CZ167	91063	91
Koleos 2.0 dCi	HY0A, HY0F, HY0G, HY0H, HY0J, HY0K, HY0L, HY0V	2.0	110	4	09.08-	M9R838	7,0	CZ167	91063	91
Koleos 2.0 dCi	HY0A, HY0F, HY0G, HY0H, HY0J, HY0K, HY0L, HY0V	2.0	110	4	09.08-	M9R850	7,0	CZ167	91063	91
Koleos 2.0 dCi	HY0B, HY0L, HY0W	2.0	127	4	06.08-	M9R830	7,0	CZ167	91063	91
Koleos 2.0 dCi	HY0B, HY0L, HY0W	2.0	127	4	07.13-	M9R830	7,0	CZ167	90646	91
Koleos 2.0 dCi	HY0B, HY0L, HY0W	2.0	127	4	07.13-	M9R864	7,0	CZ167	90646	91
Koleos 2.0 dCi	HY0B, HY0L, HY0W	2.0	127	4	07.13-	M9R865	7,0	CZ167	90646	91
Koleos 2.0 dCi	HY0B	2.0	130	4	09.08-03.13	M9R830	7,0	CZ167	91063	91
Koleos 2.0 dCi (color code: Yellow)	HCAK	2.0	130	4	08.16-	M9R868	4,5	Y1010AS	91210	88
Koleos 2.0 Blue dCi 190	HCAN	2.0	140	4	06.19-	M9R730	4,5	Y1047AS	95340	

LAGUNA

Laguna / Nevada D		2.2	62	4	09.94-	G8T706	11,0	Y-730U	6704	17
Laguna / Nevada D		2.2	62	4	09.94-	G8T752	11,0	Y-730U	6704	17
Laguna / Nevada DT Turbo		2.2	85	4	03.96-	G8T760	11,0	Y-730U	6704	17
Laguna 2		2.2	110	4	01.02-	G9T 702	11,0	Y-517J	91766	66

LAGUNA 2

Laguna 2 Estate/Break 1.9 dCi	KG05	1.9	66	4	08.03-09.07	F9Q664	12,0	Y-732J	5605	4
Laguna 2 1.9 Dci		1.9	68	4	10.03-05.05	F9Q 664	12,0	Y-732J	5605	4
Laguna 2 Dci		1.9	74	4	03.99-	F9Q 710	12,0	Y-732J	5605	4
Laguna 2 Dci		1.9	74	4	03.99-	F9Q 717	12,0	Y-732J	5605	4
Laguna 2 Dci		1.9	74	4	03.99-	F9Q 718	12,0	Y-732J	5605	4
Laguna 2 1.9 dCi	BG08	1.9	74	4	03.01-05.05	F9Q650	12,0	Y-732J	5605	4
Laguna 2 Estate/Break 1.9 dCi	KG08	1.9	74	4	03.01-05.05	F9Q650	12,0	Y-732J	5605	4
Laguna 2 1.9 Dci		1.9	77	4	06.01-05.05	F9Q 752	12,0	Y-732J	5605	4





e kW
C
y
i



Stock-No
D-POWER™

RENAULT

LAGUNA 2

Laguna 2 1.9 dCi	BG0R	1.9	79	4	03.01-09.07	F9Q754	12,0	Y-732J	5605	4
Laguna 2 Estate/Break 1.9 dCi	KG0R	1.9	79	4	03.01-09.07	F9Q754	12,0	Y-732J	5605	4
Laguna 2 1.9 Dci		1.9	81	4	01.05-08.07	F9Q 674	12,0	Y-732J	5605	4
Laguna 2 1.9 Dci		1.9	81	4	01.05-08.07	F9Q 758	12,0	Y-732J	5605	4
Laguna 2 Estate/Break 1.9 dCi	KG0G	1.9	85	4	08.05-09.07	F9Q750	12,0	Y-732J	5605	4
Laguna 2 1.9 dCi	BG0G	1.9	85	4	09.05-12.07	F9Q750	12,0	Y-732J	5605	4
Laguna 2 Dci		1.9	88	4	01.01-	F9QC 750	12,0	Y-732J	5605	4
Laguna 2 1.9 dCi	BG0G, BG10	1.9	88	4	03.01-09.07	F9Q670	12,0	Y-732J	5605	4
Laguna 2 1.9 dCi	BG0G, BG10	1.9	88	4	03.01-09.07	F9Q750	12,0	Y-732J	5605	4
Laguna 2 Estate/Break 1.9 dCi	KG0G, KG10	1.9	88	4	03.01-09.07	F9Q670	12,0	Y-732J	5605	4
Laguna 2 Estate/Break 1.9 dCi	KG0G, KG10	1.9	88	4	03.01-09.07	F9Q750	12,0	Y-732J	5605	4
Laguna 2 1.9 dCi	BG0G	1.9	92	4	09.05-12.07	F9Q750	12,0	Y-732J	5605	4
Laguna 2 Estate/Break 1.9 dCi	KG0G	1.9	92	4	09.05-12.07	F9Q750	12,0	Y-732J	5605	4
Laguna 2 1.9 Dci		1.9	96	4	03.05-12.07	F9Q758, F9Q759	12,0	Y-732J	5605	4
Laguna 2 Estate/Break 2.0 dCi	KG14, KG1S, BG14, BG1S	2.0	127	4	02.07-12.07	M9R760	7,0	CZ167	91063	91
Laguna 2 2.2 dCi 115		2.2	85	4	04.04-10.05	G9T 600	11,0	Y-517J	91766	66
Laguna 2 2.2 dCi 140		2.2	102	4	04.04-	G9T 706	11,0	Y-517J	91766	66
Laguna 2 2.2 dCi 140		2.2	102	4	04.04-	G9T 707	11,0	Y-517J	91766	66
Laguna 2 2.2 dCi 150		2.2	110	4	01.02-	G9T 710	11,0	Y-517J	91766	66

LAGUNA 3

Laguna 3		1.5	80	4	10.07-	K9K 780	12,0	Y-732J	5605	4
Laguna 3 1.5 dCi		1.5	81	4	02.08-	K9K782, K9K846, K9K849	4,4	Y1035AS	94103	77
Laguna 3 2.0 dCi	BT07, BT0J, BT14, BT1A, BT1S	2.0	96	4	10.07-12.15	M9R742	7,0	CZ167	91063	91
Laguna 3 2.0 dCi	BT07, BT0J, BT14, BT1A, BT1S	2.0	96	4	10.07-12.15	M9R744	7,0	CZ167	91063	91
Laguna 3 2.0 dCi	BT07, BT0J, BT14, BT1A, BT1S	2.0	96	4	10.07-12.15	M9R802	7,0	CZ167	91063	91
Laguna 3 Estate/Break 2.0 dCi	KT07, KT0J, KT14, KT1A, KT1S	2.0	96	4	10.07-12.15	M9R742	7,0	CZ167	91063	91
Laguna 3 Estate/Break 2.0 dCi	KT07, KT0J, KT14, KT1A, KT1S	2.0	96	4	10.07-12.15	M9R744	7,0	CZ167	91063	91
Laguna 3 Estate/Break 2.0 dCi	KT07, KT0J, KT14, KT1A, KT1S	2.0	96	4	10.07-12.15	M9R802	7,0	CZ167	91063	91
Laguna 3 2.0 dCi	BT01, BT08, BT09, BT0E, BT0K, BT12, BT1C, BT1D, BT1M, BT1W	2.0	110	4	09.07-12.15	M9R742	7,0	CZ167	91063	91
Laguna 3 2.0 dCi	BT01, BT08, BT09, BT0E, BT0K, BT12, BT1C, BT1D, BT1M, BT1W	2.0	110	4	09.07-12.15	M9R744	7,0	CZ167	91063	91
Laguna 3 2.0 dCi	BT01, BT08, BT09, BT0E, BT0K, BT12, BT1C, BT1D, BT1M, BT1W	2.0	110	4	09.07-12.15	M9R746	7,0	CZ167	91063	91





l kW C
y I



Stock-No
D-POWER

RENAULT

LAGUNA 3

Laguna 3 2.0 dCi	BT01, BT08, BT09, BT0E, BT0K, BT12, BT1C, BT1D, BT1M, BT1W DT01, DT08, DT09, DT0K, DT12, DT1C, DT1D, DT1M, DT1W	2.0	110	4	09.07-12.15	M9R748	7,0	CZ167	91063	91
Laguna 3 2.0 dCi	BT01, BT08, BT09, BT0E, BT0K, BT12, BT1C, BT1D, BT1M, BT1W DT01, DT08, DT09, DT0K, DT12, DT1C, DT1D, DT1M, DT1W	2.0	110	4	09.07-12.15	M9R754	7,0	CZ167	91063	91
Laguna 3 2.0 dCi	BT01, BT08, BT09, BT0E, BT0K, BT12, BT1C, BT1D, BT1M, BT1W DT01, DT08, DT09, DT0K, DT12, DT1C, DT1D, DT1M, DT1W	2.0	110	4	09.07-12.15	M9R802	7,0	CZ167	91063	91
Laguna 3 2.0 dCi	BT01, BT08, BT09, BT0E, BT0K, BT12, BT1C, BT1D, BT1M, BT1W DT01, DT08, DT09, DT0K, DT12, DT1C, DT1D, DT1M, DT1W	2.0	110	4	09.07-12.15	M9R805	7,0	CZ167	91063	91
Laguna 3 2.0 dCi	BT01, BT08, BT09, BT0E, BT0K, BT12, BT1C, BT1D, BT1M, BT1W DT01, DT08, DT09, DT0K, DT12, DT1C, DT1D, DT1M, DT1W	2.0	110	4	09.07-12.15	M9R808	7,0	CZ167	91063	91
Laguna 3 2.0 dCi	BT01, BT08, BT09, BT0E, BT0K, BT12, BT1C, BT1D, BT1M, BT1W DT01, DT08, DT09, DT0K, DT12, DT1C, DT1D, DT1M, DT1W	2.0	110	4	09.07-12.15	M9R814	7,0	CZ167	91063	91
Laguna 3 2.0 dCi	BT01, BT08, BT09, BT0E, BT0K, BT12, BT1C, BT1D, BT1M, BT1W DT01, DT08, DT09, DT0K, DT12, DT1C, DT1D, DT1M, DT1W	2.0	110	4	09.07-12.15	M9R845	7,0	CZ167	91063	91





e kW C
y i



Stock-No
D-POWER™

RENAULT

LAGUNA 3

Laguna 3 2.0 dCi	BT01, BT08, BT09, BT0E, BT0K, BT12, BT1C, BT1D, BT1M, BT1W	2.0	110	4	09.07-12.15	M9R854	7,0	CZ167	91063	91
Laguna 3 2.0 dCi	BT01, BT08, BT09, BT0E, BT0K, BT12, BT1C, BT1D, BT1M, BT1W	2.0	110	4	09.07-12.15	M9R858	7,0	CZ167	91063	91
Laguna 3 Estate/Break 2.0 dCi	KT01, KT08, KT09, KT0K, KT12, KT1D, KT1W	2.0	110	4	10.07-12.15	M9R742	7,0	CZ167	91063	91
Laguna 3 Estate/Break 2.0 dCi	KT01, KT08, KT09, KT0K, KT12, KT1D, KT1W	2.0	110	4	10.07-12.15	M9R744	7,0	CZ167	91063	91
Laguna 3 Estate/Break 2.0 dCi	KT01, KT08, KT09, KT0K, KT12, KT1D, KT1W	2.0	110	4	10.07-12.15	M9R802	7,0	CZ167	91063	91
Laguna 3 Estate/Break 2.0 dCi	KT01, KT08, KT09, KT0K, KT12, KT1D, KT1W	2.0	110	4	10.07-12.15	M9R805	7,0	CZ167	91063	91
Laguna 3 Estate/Break 2.0 dCi	KT01, KT08, KT09, KT0K, KT12, KT1D, KT1W	2.0	110	4	10.07-12.15	M9R845	7,0	CZ167	91063	91
Laguna 3 Estate/Break 2.0 dCi	KT01, KT08, KT09, KT0K, KT12, KT1D, KT1W	2.0	110	4	10.07-12.15	M9R854	7,0	CZ167	91063	91
Laguna 3 Estate/Break 2.0 dCi	KT01, KT08, KT09, KT0K, KT12, KT1D, KT1W	2.0	110	4	10.07-12.15	M9R858	7,0	CZ167	91063	91
Laguna 3 2.0 dCi	BT0M, BT0N, BT19 DT0M, DT0N, DT0S, DT19, DT1F	2.0	127	4	01.08-12.15	M9R800	7,0	CZ167	91063	91
Laguna 3 2.0 dCi	BT0M, BT0N, BT19 DT0M, DT0N, DT0S, DT19, DT1F	2.0	127	4	01.08-12.15	M9R809	7,0	CZ167	91063	91
Laguna 3 2.0 dCi	BT0M, BT0N, BT19 DT0M, DT0N, DT0S, DT19, DT1F	2.0	127	4	01.08-12.15	M9R815	7,0	CZ167	91063	91
Laguna 3 Estate/Break 2.0 dCi	KT0M, KT0N, KT0S, KT19, KT1F	2.0	127	4	01.08-12.15	M9R800	7,0	CZ167	91063	91
Laguna 3 Estate/Break 2.0 dCi	KT0M, KT0N, KT0S, KT19, KT1F	2.0	127	4	01.08-12.15	M9R809	7,0	CZ167	91063	91
Laguna 3 Estate/Break 2.0 dCi	KT0M, KT0N, KT0S, KT19, KT1F	2.0	127	4	01.08-12.15	M9R815	7,0	CZ167	91063	91
Laguna 3 2.0 dCi	DT0M, DT0N, DT0S, DT19, DT1F	2.0	127	4	09.08-12.15	M9R806	7,0	CZ167	91063	91
Laguna 3 2.0 dCi	BT11, BT1E, BT1N DT11, DT1E, DT1N	2.0	131	4	03.08-12.15	M9R816	7,0	CZ167	91063	91





e kW C
Y
I



Stock-No
D-POWER

RENAULT

LAGUNA 3

Laguna 3 2.0 dCi	BT11, BT1E, BT1N DT11, DT1E, DT1N	2.0	131	4	03.08-12.15	M9R820	7,0	CZ167	91063	91
Laguna 3 Estate/Break 2.0 dCi	KT11, KT1E, KT1N	2.0	131	4	03.08-12.15	M9R816	7,0	CZ167	91063	91
Laguna 3 Estate/Break 2.0 dCi	KT11, KT1E, KT1N	2.0	131	4	03.08-12.15	M9R820	7,0	CZ167	91063	91

LAGUNA PHASE II

Laguna / Nevada Phase2 Dti		1.9	74	4	10.97-	F9Q716, F9Q730, F9Q734	11,0	Y-740U	4818	22
Laguna / Nevada Phase 2		1.9	75	4	10.97-02.01	F9Q 716	11,0	Y-740U	4818	22
Laguna / Nevada Phase 2		1.9	75	4	02.99-02.01	F9Q 710	12,0	Y-732J	5605	4
Laguna / Nevada Phase2 DT		2.2	80	4	04.98-	G8T760	11,0	Y-730U	6704	17

LAGUNA PHASE III

Laguna PHASE III 2.0 dCi (color code: Yellow)	BT07, BT0J, BT14, BT1A, BT1S, KT07, KT0J, KT14, KT1A, KT1S	2.0	96	4	10.07-12.15	M9R854	4,5	Y1010AS	91210	88
Laguna PHASE III 2.0 dCi (color code: Yellow)	KT07, KT0J, KT14, KT1A, KT1S	2.0	96	4	10.07-12.15	M9R858	4,5	Y1010AS	91210	88
Laguna PHASE III 2.0 dCi (color code: Yellow)	BT01, BT08, BT09, BT0E, BT0K, BT12, BT1C, BT1D, BT1M, BT1W, DT01, DT08, DT09, DT0K, DT12, DT1C, DT1D, DT1M, DT1W	2.0	110	4	09.07-12.15	M9R858	4,5	Y1010AS	91210	88
Laguna PHASE III 2.0 dCi (color code: Yellow)	BT0M, BT0N, BT0S, BT19, BT1F	2.0	127	4	01.08-12.15	M9R858	4,5	Y1010AS	91210	88
Laguna PHASE III 2.0 dCi (color code: Yellow)	KT0M, KT0N, KT0S, KT19, KT1F, BT0M, BT0N, BT0S, BT19, BT1F, DT0M, DT0N, DT0S, DT19, DT1F	2.0	127	4	01.08-12.15	M9R857	4,5	Y1010AS	91210	88
Laguna PHASE III 2.0 dCi (color code: Yellow)	KT11, KT1E, KT1N, DT11, DT1E, DT1N, BT11, BT1E, BT1N	2.0	131	4	03.08-12.15	M9R828	4,5	Y1010AS	91210	88
Laguna PHASE III 3.0 dCi	DT03, KT03, KT13, DT0L, DT13, BT03, BT13	3.0	173	6	01.08-12.15	V9X891	7,0	CZ167	90646	91

LATITUDE

Latitude 2.0 dCi	L70C, L70V	2.0	96	4	12.13-	M9R756	7,0	CZ167	91063	91
Latitude 2.0 dCi	L70H	2.0	110	4	02.11-	M9R824	7,0	CZ167	91063	91
Latitude 2.0 dCi	L70H	2.0	110	4	02.11-	M9R846	7,0	CZ167	91063	91
Latitude 2.0 dCi	L70E, L70Y	2.0	127	4	02.11-	M9R804	7,0	CZ167	91063	91
Latitude 2.0 dCi	L70E, L70Y	2.0	127	4	02.11-	M9R817	7,0	CZ167	91063	91
Latitude 2.0 dCi	L70E, L70Y	2.0	127	4	02.11-	M9R844	7,0	CZ167	91063	91
Latitude 3.0 dCi	L70G	3.0	177	6	02.11-	V9X891	7,0	CZ167	90646	91

LOGAN

Logan I 1.5 dCi	LS0J	1.5	48	4	04.06-10.13	K9K790	12,0	Y-732J	5605	4
-----------------	------	-----	----	---	-------------	--------	------	--------	------	---





e kW y i



Stock-No
D-POWER

RENAULT

LOGAN

Logan MCV I 1.5 dCi	KS0K	1.5	50	4	04.07-11.12	K9K792	12,0	Y-732J	5605	4
---------------------	------	-----	----	---	-------------	--------	------	--------	------	---

MASTER

Master Dci		1.9	59	4	06.00-	F9Q 770	12,0	Y-732J	5605	4
Master T28 1.9 -/dCi	JD0P, JD1P, FD0P, FD8P	1.9	60	4	11.01-10.06	F9Q772	12,0	Y-732J	5605	4
Master T33 1.9 -/dCi	FD0P, FD8P	1.9	60	4	11.01-10.06	F9Q772	12,0	Y-732J	5605	4
Master T35 1.9 -/dCi	FD0P, FD8P, JD0P, JD1P	1.9	60	4	11.01-10.06	F9Q772	12,0	Y-732J	5605	4
Master T39 1.9 -/dCi	JD0P, JD1P	1.9	60	4	11.01-10.06	F9Q772	12,0	Y-732J	5605	4
Master D T30		2.1	45	4	11.81- .96	852	11,0	Y-924J	7906	1
Master Dci 16S		2.2	66	4	05.01-	G9T 720	11,0	Y-517J	91766	66
Master Dci 16S		2.2	66	4	05.01-	G9T 722	11,0	Y-517J	91766	66
Master Dci 16S		2.2	66	4	05.01-	G9T 750	11,0	Y-517J	91766	66
Master Dci		2.2	85	4	.00-	G9T 710	11,0	Y-517J	91766	66
Master 2.3 dCi 100 (color code: Red)	FV0B	2.3	74	4	12.12-	M9T890	4,5	Y1047AS	95340	
Master 2.3 dCi 100 (color code: Red)	JV0A, JV0B, JV0G, JV0H	2.3	74	4	12.12-	M9T870	4,5	Y1047AS	95340	
Master 2.3 dCi 110 (color code: Red)	FV0R, FV0W, JV0R, JV0W, EV0R, EV0W, HV0R, HV0W, UV0R, UV0W	2.3	81	4	07.14-	M9T704	4,5	Y1047AS	95340	
Master 2.3 dCi 110 (color code: Red)	EV0R, EV0W, FV0R, FV0W, HV0R, HV0W, JV0R, JV0W, UV0R, UV0W	2.3	81	4	07.14-	M9T870	4,5	Y1047AS	95340	
Master 2.3 dCi 125 (color code: Red)	JV0C, JV0D, JV0H, JV0J, EV0C, EV0D, EV0H, EV0J, EV0K, HV0C, HV0D, HV0G, HV0H, HV0J, HV0K, UV0C, UV0D, UV0G, UV0H, UV0J, UV0K, UV0M	2.3	92	4	12.12-	M9T880	4,5	Y1047AS	95340	
Master 2.3 dCi 125 (color code: Red)	EV0C, EV0D, EV0H, EV0J, EV0K, HV0C, HV0D, HV0G, HV0H, HV0J, HV0K, JV0C, JV0D, JV0J, UV0C, UV0D, UV0G, UV0H, UV0J, UV0K, UV0M	2.3	92	4	12.12-	M9T870	4,5	Y1047AS	95340	
Master 2.3 dCi 125 (color code: Red)	HV0A, HV0C, HV0D, HV0H, HV0J, HV0K, UV0A, UV0C, UV0D, UV0H, UV0J, UV0K	2.3	92	4	06.13-	M9T896	4,5	Y1047AS	95340	
Master 2.3 dCi 130 (color code: Red)	FV0Y, EV0Y, HV0Y, UV0Y	2.3	96	4	07.15-	M9T704	4,5	Y1047AS	95340	
Master 2.3 dCi 130 (color code: Red)	HV01, HV11, UV01, UV11	2.3	96	4	07.15-	M9T710	4,5	Y1047AS	95340	
Master 2.3 dCi 135 (color code: Red)	FV08, FV0N, JV0N, EV08, EV0N, HV08, HV0N, UV08, UV0N	2.3	100	4	07.14-	M9T702	4,5	Y1047AS	95340	





l kW C
y i



Stock-No
D-POWER

RENAULT

MASTER

Master 2.3 dCi 135 (color code: Red)	EV08, EV0N, FV08, FV0N, HV08, HV0N, UV08, UV0N	2.3	100	4	07.14-	M9T716	4,5	Y1047AS	95340	
Master 2.3 dCi 135 (color code: Red)	HV0N, UV0N, FV0N	2.3	100	4	07.14-	M9T700	4,5	Y1047AS	95340	
Master 2.3 dCi 145 (color code: Red)	JV0S, JV0T	2.3	107	4	07.15-	M9T706	4,5	Y1047AS	95340	
Master 2.3 dCi 145 (color code: Red)	JV0S, JV0T	2.3	107	4	07.15-	M9T708	4,5	Y1047AS	95340	
Master 2.3 dCi 150 (color code: Red)	EV03, EV0F, FV03, FV0F, HV03, HV0F, JV0F, JV03, UV03, UV0F	2.3	110	4	03.13-	M9T880	4,5	Y1047AS	95340	
Master 2.3 dCi 150 (color code: Red)	FV0F, HV0F, UV0F	2.3	110	4	03.13-	M9T896	4,5	Y1047AS	95340	
Master 2.3 dCi 150 (color code: Red)	FV0F, HV0F, UV0F	2.3	110	4	03.13-	M9T898	4,5	Y1047AS	95340	
Master 2.3 dCi 150 (color code: Red)	EV03, EV0F, FV03, FV0F, HV03, HV0F, JV03, JV0F, UV03, UV0F	2.3	110	4	03.13-	M9T716	4,5	Y1047AS	95340	
Master 2.3 dCi 165 (color code: Red)	FV0P, FV0U, JV0P, EV0P, EV0U, HV0P, HV0U, UV0P, UV0U	2.3	120	4	07.14-	M9T702	4,5	Y1047AS	95340	
Master 2.3 dCi 165 (color code: Red)	HV0P, HV0U, UV0P, UV0U, FV0P, FV0U	2.3	120	4	07.14-	M9T700	4,5	Y1047AS	95340	
Master 2.3 dCi 165 (color code: Red)	HV0P, HV0U, UV0P, UV0U, FV0P, FV0U	2.3	120	4	07.14-	M9T710	4,5	Y1047AS	95340	
Master 2.3 dCi 165 (color code: Red)	EV0P, EV0U, FV0P, FV0U, HV0P, HV0U, JV0U, UV0P, UV0U, UV0U	2.3	120	4	07.14-	M9T708	4,5	Y1047AS	95340	
Master 2.3 dCi 170 (color code: Red)	FV0L, JV0L, EV0L, HV0L, UV0L	2.3	125	4	07.15-	M9T706	4,5	Y1047AS	95340	
Master 2.3 dCi 180 (color code: Red)	EV04, HV04, UV04, FV04, JV04	2.3	132	4	07.19-	M9T716	4,5	Y1047AS	95340	
Master Turbo D T35		2.5	55	4	06.82- .96	S9U	11,0	Y-924J	7906	1
Master D		2.5	59	4	07.98-	S8U 770	11,0	Y-502R	3852	
Master D		2.5	59	4	07.98-	S8U 772	11,0	Y-502R	3852	
Master D		2.5	69	4	09.97-	S8V 748	11,5	Y-910J	3617	3
Master 2.5 dCi 100 T28, T33, T35		2.5	73	4	10.03-	G9U 754	11,0	Y-517J	91766	66
Master 2.5 dCi 100 T28, T33, T35		2.5	74	4	08.06-	G9U 754	11,0	Y-517J	91766	66
Master 2.5 Dci 115 T28, T35, T39		2.5	84	4	10.01-	G9U720, G9U750	11,0	Y-517J	91766	66
Master Dci 16S		2.5	88	4	10.00-	G9U720, G9U754	11,0	Y-517J	91766	66
Master 2.5 Dci 120 T28, T35, T39		2.5	88	4	08.06-	G9U 650	11,0	Y-517J	91766	66
Master 2.5 Dci 150 T28, T35, T39		2.5	107	4	08.06-	G9U 632	11,0	Y-517J	91766	66
Master Dti		2.8	85	4	09.97-	S8W700, S8W702	11,0	Y-502R	3852	
Master Dci		3.0	96	4	01.07-	ZD30CDTi	11,0	Y-522J	5939	
Master T28, T33, T35				4	07.98-		11,0	Y-502R	3852	
Master PHASE III 2.3 dCi 100	FV0B, FV0H, FV0K	2.3	74	4	02.10-11.12	M9T890	7,0	CZ167	90646	91





e kW C y i



Stock-No
D-POWER™

RENAULT

MASTER

Master PHASE III 2.3 dCi 100	EV0A, EV0B, EV0H, EV0K, FV0A, FV0B, FV0G, FV0H, FV0K, HV0A, HV0B, HV0G, HV0H, HV0K, JV0A, JV0B, JV0G, JV0H, UV0A, UV0B, UV0G, UV0H, UV0K	2.3	74	4	02.10-	M9T676	7,0	CZ167	90646	91
Master PHASE III 2.3 dCi 100	EV0A, EV0B, EV0H, EV0K, FV0A, FV0B, FV0G, FV0H, FV0K, JV0A, JV0B, JV0C, JV0D, JV0G, JV0H, JV0J, HV0A, HV0B, HV0G, HV0H, HV0K, UV0A, UV0B, UV0G, UV0H, UV0K	2.3	74	4	02.10-	M9T670	7,0	CZ167	90646	91
Master PHASE III 2.3 dCi 100	FV0B, FV0G, FV0K, FV0A, FV0H, EV0A, EV0B, EV0H, EV0K, HV0A, HV0B, HV0G, HV0H, HV0K, UV0A, UV0B, UV0G, UV0H, JV0A, JV0B, JV0G, JV0H	2.3	74	4	02.10-	M9T672	7,0	CZ167	90646	91
Master PHASE III 2.3 dCi 100	EV0A, EV0B, EV0H, EV0K, FV0A, FV0B, FV0G, FV0H, FV0K, HV0A, HV0B, HV0G, HV0H, HV0K, JV0A, JV0B, JV0G, JV0H, UV0A, UV0B, UV0G, UV0H, UV0K	2.3	74	4	02.10-	M9T870	7,0	CZ167	90646	91
Master PHASE III 2.3 dCi 100	HV0B, HV0H, HV0K, UV0B, UV0H, UV0K, FV0B, , FV0H, FV0K	2.3	74	4	02.10-	M9T690	7,0	CZ167	90646	91
Master PHASE III 2.3 dCi 100	HV0B, HV0H, HV0K, UV0B, UV0H, UV0K, FV0B, , FV0H, FV0K	2.3	74	4	02.10-	M9T892	7,0	CZ167	90646	91
Master PHASE III 2.3 dCi 125	FV0C, FV0D, FV0G, FV0H, FV0J, FV0K, FV0M, JV0C, JV0D, JV0H, JV0J, HV0C, HV0D, HV0G, HV0H, HV0J, HV0K, UV0C, UV0D, UV0G, UV0H, UV0J, UV0K, UV0M, EV0C, EV0D, EV0H, EV0J, EV0K,	2.3	92	4	02.10-	M9T670	7,0	CZ167	90646	91





l kW C
y I



Stock-No
D-POWER

RENAULT

MASTER

Master PHASE III 2.3 dCi 125	FV0C, FV0D, FV0G, FV0H, FV0J, FV0K, FV0M, JV0C, JV0D, JV0H, JV0J, HV0C, HV0D, HV0G, HV0H, HV0J, HV0K, UV0C, UV0D, UV0G, UV0H, UV0J, UV0K, UV0M, EV0C, EV0D, EV0H, EV0J, EV0K	2,3	92	4	02.10-	M9T672	7,0	CZ167	90646	91
Master PHASE III 2.3 dCi 125	EV0C, EV0D, EV0H, EV0J, EV0K, FV0C, FV0D, FV0G, FV0H, FV0J, FV0K, FV0M, HV0C, HV0D, HV0G, HV0H, HV0J, HV0K, JV0C, JV0D, JV0H, JV0J, UV0C, UV0D, UV0G, UV0H, UV0J, UV0K, UV0M	2,3	92	4	02.10-	M9T676	7,0	CZ167	90646	91
Master PHASE III 2.3 dCi 125	FV0C, FV0D, FV0G, FV0H, FV0J, FV0K, FV0M, EV0C, EV0D, EV0H, EV0J, EV0K, HV0C, HV0D, HV0G, HV0H, HV0J, HV0K, UV0C, UV0D, UV0G, UV0H, UV0J, UV0K, UV0M, JV0C, JV0D, JV0H, JV0J	2,3	92	4	02.10-	M9T680	7,0	CZ167	90646	91
Master PHASE III 2.3 dCi 125	EV0C, EV0D, EV0H, EV0J, EV0K, FV0C, FV0D, FV0G, FV0H, FV0J, FV0K, HV0C, HV0D, HV0G, HV0H, HV0J, HV0K, JV0C, JV0D, JV0H, JV0J, UV0C, UV0D, UV0G, UV0H, UV0J, UV0K, UV0M	2,3	92	4	02.10-	M9T870	7,0	CZ167	90646	91
Master PHASE III 2.3 dCi 125	EV0C, EV0D, EV0H, EV0J, EV0K, FV0C, FV0D, FV0G, FV0H, FV0J, FV0K, FV0M, HV0C, HV0D, HV0G, HV0H, HV0J, HV0K, , UV0C, UV0D, UV0G, UV0H, UV0J, UV0K, UV0M	2,3	92	4	02.10-	M9T872	7,0	CZ167	90646	91





e kW C y i



Stock-No
D-POWER™

RENAULT

MASTER

Master PHASE III 2.3 dCi 125	EV0C, EV0D, EV0H, EV0J, EV0, FV0C, FV0D, FV0G, FV0H, FV0J, FV0K, FV0M, HV0C, HV0D, HV0G, HV0H, HV0J, HV0K, UV0C, UV0D, UV0G, UV0H, UV0J, UV0K, UV0M	2.3	92	4	02.10-	M9T876	7,0	CZ167	90646	91
Master PHASE III 2.3 dCi 125	EV0C, EV0D, EV0H, EV0J, EV0K, FV0C, FV0D, FV0G, FV0H, FV0J, FV0K, FV0M, HV0C, HV0D, HV0G, HV0H, HV0J, HV0K, UV0C, UV0D, UV0G, UV0H, UV0J, UV0K, UV0M	2.3	92	4	02.10-	M9T880	7,0	CZ167	90646	91
Master PHASE III 2.3 dCi 125	EV0C, EV0D, EV0H, EV0J, EV0K, FV0C, FV0D, FV0G, FV0H, FV0J, FV0K, FV0M, HV0C, HV0D, HV0G, HV0H, HV0J, HV0K, UV0C, UV0D, UV0G, UV0H, UV0J, UV0K, UV0M	2.3	92	4	02.10-	M9T882	7,0	CZ167	90646	91
Master PHASE III 2.3 dCi 125	FV0A, FV0C, FV0D, FV0H, FV0J, FV0K, HV0A, HV0C, HV0D, HV0H, HV0J, HV0K, UV0A, UV0C, UV0D, UV0H, UV0J, UV0K	2.3	92	4	02.10-	M9T686	7,0	CZ167	90646	91
Master PHASE III 2.3 dCi 125	FV0A, FV0C, FV0D, FV0H, FV0J, FV0K, HV0A, HV0C, HV0D, HV0H, HV0J, HV0K, UV0A, UV0C, UV0D, UV0H, UV0J, UV0K	2.3	92	4	02.10-	M9T690	7,0	CZ167	90646	91
Master PHASE III 2.3 dCi 125	FV0A, FV0C, FV0D, FV0H, FV0J, FV0K, HV0A, HV0C, HV0D, HV0H, HV0J, HV0K, UV0A, UV0C, UV0D, UV0H, UV0J, UV0K	2.3	92	4	02.10-	M9T692	7,0	CZ167	90646	91





l kW C
Y I



Stock-No
D-POWER

RENAULT

MASTER

Master PHASE III 2.3 dCi 125	FV0A, FV0C, FV0D, FV0H, FV0J, FV0K, HV0A, HV0C, HV0D, HV0H, HV0J, HV0K, UV0A, UV0C, UV0D, UV0H, UV0J, UV0K	2.3	92	4	02.10-	M9T696	7,0	CZ167	90646	91
Master PHASE III 2.3 dCi 125	FV0A, FV0C, FV0D, FV0H, FV0J, FV0K, HV0A, HV0C, HV0D, HV0H, HV0J, HV0K, UV0A, UV0C, UV0D, UV0H, UV0J, UV0K	2.3	92	4	02.10-	M9T698	7,0	CZ167	90646	91
Master PHASE III 2.3 dCi 125	FV0A, FV0C, FV0D, FV0H, FV0J, FV0K, HV0A, HV0C, HV0D, HV0H, HV0J, HV0K, UV0A, UV0C, UV0D, UV0H, UV0J, UV0K	2.3	92	4	02.10-	M9T890	7,0	CZ167	90646	91
Master PHASE III 2.3 dCi 125	FV0A, FV0C, FV0D, FV0H, FV0J, FV0K, HV0A, HV0C, HV0D, HV0H, HV0J, HV0K, UV0A, UV0C, UV0D, UV0H, UV0J, UV0K	2.3	92	4	02.10-	M9T892	7,0	CZ167	90646	91
Master PHASE III 2.3 dCi 125	FV0A, FV0C, FV0D, FV0H, FV0J, FV0K, HV0A, HV0C, HV0D, HV0H, HV0J, HV0K, UV0A, UV0C, UV0D, UV0H, UV0J, UV0K	2.3	92	4	02.10-	M9T896	7,0	CZ167	90646	91
Master PHASE III 2.3 dCi 125	FV0A, FV0C, FV0D, FV0H, FV0J, FV0K, HV0A, HV0C, HV0D, HV0H, HV0J, HV0K, UV0A, UV0C, UV0D, UV0H, UV0J, UV0K	2.3	92	4	02.10-	M9T898	7,0	CZ167	90646	91
Master PHASE III 2.3 dCi 145	FV0E, FV0F, FV0T, HV0F, HV0T, UV0E, UV0F, UV0T	2.3	107	4	02.10-	M9T694	7,0	CZ167	90646	91
Master PHASE III 2.3 dCi 145	FV0E, FV0F, FV0T, HV0F, HV0T, UV0E, UV0F, UV0T	2.3	107	4	02.10-	M9T696	7,0	CZ167	90646	91
Master PHASE III 2.3 dCi 145	FV0E, FV0F, FV0T, HV0F, HV0T, UV0E, UV0F, UV0T	2.3	107	4	02.10-	M9T698	7,0	CZ167	90646	91
Master PHASE III 2.3 dCi 145	FV0E, FV0F, FV0T, HV0F, HV0T, UV0E, UV0F, UV0T	2.3	107	4	02.10-	M9T710	7,0	CZ167	90646	91





e kW C
y i



Stock-No
D-POWER™

RENAULT

MASTER

Master PHASE III 2.3 dCi 145	FV0E, FV0F, FV0H, FV0M, FV0S, FV0T, JV0F, JV0H, JV0S	2.3	107	4	02.10-	M9T672	7,0	CZ167	90646	91
Master PHASE III 2.3 dCi 145	FV0E, FV0F, FV0H, FV0M, FV0S, FV0T, EVOE, EV0F, EV0S, EV0T, HVOE, HVOF, HV0S, HV0T, UV0E, UV0F, UV0M, UV0S, UV0T	2.3	107	4	02.10-	M9T678	7,0	CZ167	90646	91
Master PHASE III 2.3 dCi 145	FV0E, FV0F, FV0H, FV0M, FV0S, FV0T, EVOE, EV0F, EV0S, EV0T, HVOE, HVOF, HV0S, HV0T, UV0E, UV0F, UV0M, UV0S, UV0T, JV0F, JV0H, JV0S	2.3	107	4	02.10-	M9T680	7,0	CZ167	90646	91
Master PHASE III 2.3 dCi 145	FV0E, FV0F, FV0H, FV0M, FV0S, FV0T, EVOE, EV0F, EV0S, EV0T, HVOE, HVOF, HV0S, HV0T, UV0E, UV0F, UV0M, UV0S, UV0T, JV0F, JV0H, JV0S	2.3	107	4	02.10-	M9T706	7,0	CZ167	90646	91
Master PHASE III 2.3 dCi 145	FV0E, FV0F, FV0H, FV0M, FV0S, FV0T, EVOE, EV0F, EV0S, EV0T, HVOE, HVOF, HV0S, HV0T, UV0E, UV0F, UV0M, UV0S, UV0T	2.3	107	4	02.10-	M9T708	7,0	CZ167	90646	91
Master PHASE III 2.3 dCi 150	FV03, FV0F	2.3	110	4	03.13-05.13	M9T716	7,0	CZ167	90646	91
Master PHASE III 2.3 dCi 150	FV03, FV0F, JV0F	2.3	110	4	03.13-05.13	M9T880	7,0	CZ167	90646	91
Master PHASE III 2.3 dCi 150	HV0F, UV0F, FV0F	2.3	110	4	03.13-	M9T896	7,0	CZ167	90646	91
Master PHASE III 2.3 dCi 150	HV0F, UV0F	2.3	110	4	03.13-	M9T898	7,0	CZ167	90646	91

MEGANE

Megane / Classic D		1.9	48	4	01.96-	F8Q 620	11,0	Y-927J	4916	19
Megane / Classic D		1.9	48	4	01.96-	F8Q 624	11,0	Y-927J	4916	19
Megane / Classic D		1.9	48	4	03.98-	F8Q 788	11,0	Y-506J	2419	7
Megane / Classic D		1.9	48	4	03.99-02.01	F8Q 622	11,0	Y-516J	6416	12
Megane Classic 1.9 dCi/DTi	LA01, LA08, LA1U	1.9	59	4	02.00-07.03	F9Q738	12,0	Y-732J	5605	4
Megane 1.9 dCi/DTi	SA01, SA1U	1.9	59	4	10.00-07.03	F9Q738	12,0	Y-732J	5605	4
Megane 1.9 Dti		1.9	59	4	02.01-	F9Q 744	12,0	Y-732J	5605	4
Megane Estate/Break 1.9 dCi/DTi	KA01, KA1U	1.9	59	4	02.01-08.03	F9Q738	12,0	Y-732J	5605	4
Megane / Classic Di		1.9	66	4	01.96-08.99	F9Q 730	11,0	Y-740U	4818	22
Megane / Classic Di		1.9	66	4	01.96-08.99	F9Q 734	11,0	Y-740U	4818	22





ℓ kW C
Y I



Stock-No
D-POWER

RENAULT

MEGANE

Megane / Classic DT		1.9	66	4	01.96-	F8Q 784	11,0	Y-933J	7947	25
Megane / Classic DT		1.9	66	4	01.96-	F8Q 786	11,0	Y-933J	7947	25
Megane / Classic Dti		1.9	74	4	01.96-	F9Q716, F9Q730, F9Q734	11,0	Y-740U	4818	22
Megane / Classic Dci		1.9	77	4	03.99-	F9Q731, F9Q732, F9Q736, F9Q740	12,0	Y-732J	5605	4
Megane / Classic Dci		1.9	77	4	03.99-	F9Q 732	12,0	Y-732J	5605	4
Megane / Classic Dci		1.9	77	4	03.99-	F9Q 736	12,0	Y-732J	5605	4
Megane Classic 1.9 dCi	LA05	1.9	77	4	03.99-07.03	F9Q733	12,0	Y-732J	5605	4
Megane Coupe 1.9 dCi	DA05	1.9	77	4	03.99-07.03	F9Q733	12,0	Y-732J	5605	4

MEGANE 2

Megane 2 1.5 Dci		1.5	59	4	09.02-	K9K 722	12,0	Y-732J	5605	4
Megane 2 1.5 Dci Berline		1.5	59	4	09.03-	K9K 722	12,0	Y-732J	5605	4
Megane 2 1.5 Dci Break		1.5	59	4	09.03-	K9K 722	12,0	Y-732J	5605	4
Megane 2 1.5 dCi	SM0F	1.5	60	4	08.03-02.08	K9K722	12,0	Y-732J	5605	4
Megane Van 1.5 dCi	KM0F	1.5	60	4	08.03-07.09	K9K722	12,0	Y-732J	5605	4
Megane 2 1.5 Dci		1.5	63	4	05.05-02.08	K9K 724	12,0	Y-732J	5605	4
Megane 2 1.5 dCi	SM1F	1.5	63	4	05.05-02.08	K9K724	12,0	Y-732J	5605	4
Megane Van 1.5 dCi	KM1F	1.5	63	4	05.05-07.09	K9K724	12,0	Y-732J	5605	4
Megane 2 1.5 dCi	SM02	1.5	74	4	08.03-02.08	K9K728	12,0	Y-732J	5605	4
Megane Van 1.5 dCi	KM02	1.5	74	4	08.03-07.09	K9K728	12,0	Y-732J	5605	4
Megane 2 Coupe		1.5	74	4	.04-	K9K	12,0	Y-732J	5605	4
Megane 2 1.5 Dci		1.5	76	4	05.05-07.09	K9K 728	12,0	Y-732J	5605	4
Megane 2 1.5 dCi	SM16	1.5	76	4	01.07-03.09	K9K734	12,0	Y-732J	5605	4
Megane Van 1.5 dCi	KM1E	1.5	78	4	08.03-07.09	K9K732	12,0	Y-732J	5605	4
Megane 2 1.5 Dci		1.5	78	4	05.05-07.09	K9K 732	12,0	Y-732J	5605	4
Megane 2 1.5 Dci		1.5	78	4	05.05-07.09	K9K 734	12,0	Y-732J	5605	4
Megane 2 1.5 dCi	SM1E	1.5	78	4	05.05-02.08	K9K732	12,0	Y-732J	5605	4
Megane 2 1.9 dCi	BM00, CM00, LM00	1.9	66	4	11.02-12.05	F9Q808	12,0	Y-732J	5605	4
Megane Estate/Break 1.9 dCi	KM00	1.9	66	4	04.04-12.05	F9Q808	12,0	Y-732J	5605	4
Megane Estate/Break 1.9 dCi	KM00	1.9	68	4	08.03-02.07	F9Q808	12,0	Y-732J	5605	4
Megane 2 1.9 dCi	BM00, CM00, LM00	1.9	68	4	03.04-08.06	F9Q808	12,0	Y-732J	5605	4
Megane 2 1.9 Dci		1.9	81	4	05.05-	F9Q 803	12,0	Y-732J	5605	4
Megane 2 1.9 Dci		1.9	81	4	05.05-	F9Q 804	12,0	Y-732J	5605	4
Megane 2 1.9 Dci		1.9	81	4	05.05-	F9Q 818	12,0	Y-732J	5605	4
Megane 2 1.9 Dci		1.9	85	4	11.02-03.09	F9Q 818	12,0	Y-732J	5605	4
Megane 2 Coupe Dci		1.9	88	4	09.02-	F9Q 800	12,0	Y-732J	5605	4
Megane 2 1.9 Dci		1.9	96	4	05.05-	F9Q803, F9Q816	12,0	Y-732J	5605	4
Megane Estate/Break 1.9 dCi	KM14	1.9	96	4	02.06-10.06	F9Q804	12,0	Y-732J	5605	4
Megane 2 2.0 dCi	BM1K, CM1K	2.0	110	4	02.07-02.08	M9R722	7,0	CZ167	91063	91
Megane 2 Estate/Break 2.0 dCi	KM1K	2.0	110	4	02.07-07.09	M9R700	7,0	CZ167	91063	91
Megane 2 Estate/Break 2.0 dCi	KM1K	2.0	110	4	02.07-07.09	M9R722	7,0	CZ167	91063	91
Megane 2 CC 2.0 dCi	EM1K	2.0	110	4	02.07-03.09	M9R700	7,0	CZ167	91063	91
Megane 2 CC 2.0 dCi	EM1K	2.0	110	4	02.07-03.09	M9R722	7,0	CZ167	91063	91
Megane 2 2.0 dCi	LM1K, BM1K, CM1K	2.0	110	4	02.07-11.08	M9R700	7,0	CZ167	91063	91
Megane 2 2.0 dCi	BM1W, CM1W	2.0	127	4	02.07-02.08	M9R724	7,0	CZ167	91063	91





e kW
C
y
i



Stock-No
D-POWER™

RENAULT

MEGANE 3

Megane 3 1.5 dCi		1.5	63	4	12.09-	K9K 830		4,4	Y1035AS	94103	77
Megane 3 1.5 dCi		1.5	66	4	11.08-	K9K 834		4,4	Y1035AS	94103	77
Megane 3 1.5 dCi		1.5	78	4	02.09-	K9K 832		4,4	Y1035AS	94103	77
Megane 3 1.5 dCi		1.5	81	4	02.09-	K9K 836		4,4	Y1035AS	94103	77
Megane 1.6 dCi		1.6	96	4	04.11-	R9M402		4,5	Y1010AS	97618	88
Megane 1.6 dCi		1.6	96	4	04.11-	R9M404		4,5	Y1010AS	97618	88
Megane 1.6 dCi CC		1.6	96	4	04.11-	R9M402		4,5	Y1010AS	97618	88
Megane 1.6 dCi Coupe		1.6	96	4	04.11-	R9M402		4,5	Y1010AS	97618	88
Megane 1.6 dCi Coupe		1.6	96	4	04.11-	R9M404		4,5	Y1010AS	97618	88
Megane Estate/Break		1.6	96	4	04.11-	R9M402		4,5	Y1010AS	97618	88
Megane Estate/Break		1.6	96	4	04.11-	R9M404		4,5	Y1010AS	97618	88
Megane Estate/Break		1.6	96	4	04.11-	R9M414		4,5	Y1010AS	97618	88
Megane 1.6 dCi		1.6	96	4	11.15-	R9M409		4,5	Y1010AS	97618	88
Megane 1.6 dCi		1.6	96	4	11.15-	R9M410		4,5	Y1010AS	97618	88
Megane 1.6 dCi		1.6	96	4	11.15-	R9M412		4,5	Y1010AS	97618	88
Megane 1.6 dCi		1.6	96	4	11.15-	R9M452		4,5	Y1010AS	97618	88
Megane 3 1.9 dCi		1.9	96	4	06.08-	F9Q 870		4,4	Y1036AS	96062	
Megane 3 1.9 dCi		1.9	96	4	06.08-	F9Q 872		4,4	Y1036AS	96062	
Megane 3 2.0 dCi	BZ0Y	2.0	110	4	06.09-08.15	M9R615		7,0	CZ167	91063	91
Megane 3 Coupe 2.0 dCi	DZ0Y	2.0	110	4	06.09-08.15	M9R615		7,0	CZ167	91063	91
Megane 3 Estate/Break 2.0 dCi	KZ0Y	2.0	110	4	08.09-08.15	M9R615		7,0	CZ167	91063	91
Megane 3 2.0 dCi	BZ0L	2.0	118	4	04.09-08.15	M9R610		7,0	CZ167	91063	91
Megane 3 Coupe 2.0 dCi	DZ0L, DZ27	2.0	118	4	04.09-08.15	M9R610		7,0	CZ167	91063	91
Megane 3 Estate/Break 2.0 dCi	KZ0L, KZ27	2.0	118	4	04.09-08.15	M9R610		7,0	CZ167	91063	91
Megane 3 CC 2.0 dCi	EZ0L	2.0	118	4	06.10-08.15	M9R610		7,0	CZ167	91063	91
Megane 3 2.0 dCi	BZ0L, BZ27	2.0	120	4	07.12-08.15	M9R610		7,0	CZ167	91063	91
Megane 3 Coupe 2.0 dCi	DZ0L, DZ27	2.0	120	4	07.12-08.15	M9R610		7,0	CZ167	91063	91
Megane 3 Estate/Break 2.0 dCi	KZ0L, KZ27	2.0	120	4	07.12-08.15	M9R610		7,0	CZ167	91063	91

MEGANE 4

Megane 4 1.7 Blue dCi 150	B9A7, K9A7	1.7	110	4	02.19-	R9N401		4,5	Y1047AS	95340	
---------------------------	-------------------	-----	-----	---	--------	--------	--	-----	---------	-------	--

MEGANE PHASE II

Megane Phase 2 D		1.9	48	4	03.99-	F8Q622, F8Q790		11,0	Y-516J	6416	12
Megane Phase 2 D		1.9	48	4	09.99-	F8Q620, F8Q624		11,0	Y-927J	4916	19
Megane Phase 2 Dti		1.9	59	4	04.01-	F9QT 770		12,0	Y-732J	5605	4
Megane Phase 2 Dti		1.9	74	4	01.96-	F9Q716, F9Q730, F9Q734		11,0	Y-740U	4818	22
Megane Phase 2 Dci		1.9	77	4	03.99-	F9Q718, F9Q722, F9Q731, F9Q736, F9Q780		12,0	Y-732J	5605	4

MEGANE PHASE IV

Megane PHASE IV 1.6 dCi (color code: Yellow)	K9A4	1.6	96	4	04.16-	R9M409		4,5	Y1010AS	91210	88
Megane PHASE IV 1.6 dCi (color code: Yellow)	K9A4	1.6	96	4	04.16-	R9M412		4,5	Y1010AS	91210	88
Megane PHASE IV 1.6 dCi (color code: Yellow)	B9A5, K9A5	1.6	120	4	11.15-	R9M452		4,5	Y1010AS	91210	88

MEGANE SCENIC

Megane Scenic		1.9	48	4	10.96-08.99	F8Q620, F8Q624		11,0	Y-927J	4916	19
Megane Scenic		1.9	48	4	03.98-	F8Q 788		11,0	Y-506J	2419	7
Megane Scenic		1.9	48	4	03.99-	F8Q622, F8Q790		11,0	Y-516J	6416	12





l kW C
Y
I



Stock-No
D-POWER

RENAULT

MEGANE SCENIC

Megane Scenic	1.9	66	4	01.96-	F8Q784, F8Q786	11,0	Y-933J	7947	25
Megane Scenic Di	1.9	66	4	10.96-08.99	F9Q716, F9Q730, F9Q734	11,0	Y-740U	4818	22
Megane Scenic Dti	1.9	74	4	01.96-	F9Q716, F9Q730, F9Q734	11,0	Y-740U	4818	22

MODUS

Modus 1.5 Dci	1.5	48	4	09.04-	K9K 752	12,0	Y-732J	5605	4	
Grand Modus 1.5 dCi	JPOG	1.5	48	4	08.07-12.13	K9K762	12,0	Y-732J	5605	4
Modus 1.5 Dci	1.5	50	4	12.04-	K9K 768	12,0	Y-732J	5605	4	
Modus 1.5 Dci 75	1.5	55	4	10.10-	K9K 770	4,4	Y1035AS	94103	77	
Modus 1.5 Dci	1.5	60	4	09.04-	K9K 750	12,0	Y-732J	5605	4	
Modus 1.5 Dci	1.5	63	4	12.04-	K9K 766	12,0	Y-732J	5605	4	
Modus 1.5 dCi	FPOF, JPOF, JP17	1.5	63	4	12.04-12.13	K9K760	12,0	Y-732J	5605	4
Grand Modus 1.5 dCi	JPOF, JP17	1.5	63	4	08.07-12.13	K9K760	12,0	Y-732J	5605	4
Modus 1.5 Dci 90	1.5	65	4	10.10-	K9K 770	4,4	Y1035AS	94103	77	
Modus 1.5 Dci	1.5	76	4	05.07-	K9K 772	12,0	Y-732J	5605	4	
Modus 1.5 dCi	FPOF, JPOF, JPOH	1.5	78	4	04.05-12.13	K9K760	12,0	Y-732J	5605	4
Modus 1.5 Dci	1.5	78	4	05.05-	K9K 764	12,0	Y-732J	5605	4	

R 19

R 19 D	1.9	48	4	06.88-02.91	F8Q	11,0	Y-924J	7906	1
R 19 D	1.9	48	4	03.91-12.95	F8Q706, F8Q742, F8Q764	11,0	Y-913J	5317	15
R 19 TD	1.9	66	4	09.90-06.96	F8Q610, F8Q740, F8Q744, F8Q768	11,0	Y-933J	7947	25

R 21

R 21 D / Nevada	1.9	48	4	09.89-02.91	F8Q	11,0	Y-924J	7906	1
R 21 D / Nevada	1.9	48	4	03.91- .95	F8Q 710	11,0	Y-924J	7906	1
R 21 D / Nevada	2.1	53	4	09.89-12.93	J8S	11,0	Y-924J	7906	1
R 21 TD / Nevada	2.1	65	4	03.86-12.93	J8S	11,0	Y-924J	7906	1

R 25

R 25 D	2.1	47	4	01.84-12.92	J8S 736	11,0	Y-924J	7906	1
R 25 TD	2.1	63	4	01.84-12.92	J8S708, J8S738	11,0	Y-924J	7906	1

RAPID

Rapid Express	1.9	34	4	09.94-	F8Q 640	11,0	Y-927J	4916	19
Rapid	1.9		4	03.86-		11,0	Y-913J	5317	15

SAFRANE

Safrane DT	2.1	65	4	06.92-09.96	J8S 760	11,0	Y-924J	7906	1
Safrane DT	2.5	83	4	03.93-09.96	S8U762, S8U763	11,0	Y-924J	7906	1

SAFRANE PHASE II

Safrane Phase 2 DT	2.2	85	4	10.96-11.00	G8T 740	11,0	Y-730U	6704	17
--------------------	-----	----	---	-------------	---------	------	--------	------	----

SCENIC

Scenic 3 1.6 dCi	1.6	96	4	04.11-	R9M414	4,5	Y1010AS	97618	88
Scenic D	1.9	48	4	10.96-08.99	F8Q620, F8Q624	11,0	Y-927J	4916	19
Scenic D	1.9	48	4	03.98-	F8Q 788	11,0	Y-506J	2419	7
Scenic D	1.9	48	4	03.99-	F8Q 622	11,0	Y-516J	6416	12
Scenic D	1.9	48	4	03.99-	F8Q 790	11,0	Y-516J	6416	12
Scenic DT	1.9	66	4	01.96-	F8Q784, F8Q786	11,0	Y-933J	7947	25
Scenic Di	1.9	66	4	10.96-08.99	F9Q716, F9Q730, F9Q734	11,0	Y-740U	4818	22





e kW
C
y
i



Stock-No
D-POWER™

RENAULT

SCENIC

Scenic Dti	1.9	74	4	01.96-	F9Q716, F9Q730, F9Q734	11,0	Y-740U	4818	22
Scenic dci RX4	1.9	75	4	.99-		12,0	Y-732J	5605	4

SCENIC 2

Scenic 2 1.5 Dci	1.5	59	4	.03-	K9K	12,0	Y-732J	5605	4	
Scenic 2 1.5 Dci	1.5	63	4	05.05-11.08	K9K 722	12,0	Y-732J	5605	4	
Scenic 2 1.5 Dci	1.5	63	4	05.05-11.08	K9K 724	12,0	Y-732J	5605	4	
Scenic 2 1.5 Dci	1.5	74	4	04.04-	K9K 728	12,0	Y-732J	5605	4	
Scenic 2 1.5 Dci	1.5	74	4	04.04-	K9K 729	12,0	Y-732J	5605	4	
Scenic 2 1.5 Dci	1.5	74	4	.04-	K9K	12,0	Y-732J	5605	4	
Grand Scenic 2 1.5 dCi	JM16	1.5	76	4	06.06-11.08	K9K734	12,0	Y-732J	5605	4
Scenic 2 1.9 Dci	1.9	81	4	05.05-	F9Q 803	12,0	Y-732J	5605	4	
Scenic 2 1.9 Dci	1.9	81	4	05.05-	F9Q 812	12,0	Y-732J	5605	4	
Grand Scenic 2 1.9 dCi	JM0G, JM12, JM15, JM1D, JM2C	1.9	85	4	05.05-01.09	F9Q803	12,0	Y-732J	5605	4
Grand Scenic 2 1.9 dCi	JM0G, JM12, JM15, JM1D, JM2C	1.9	85	4	05.05-01.09	F9Q804	12,0	Y-732J	5605	4
Grand Scenic 2 1.9 dCi	JM0G, JM12, JM15, JM1D, JM2C	1.9	85	4	05.05-01.09	F9Q812	12,0	Y-732J	5605	4
Scenic 2 1.9 Dci	1.9	88	4	04.04-	F9Q 812	12,0	Y-732J	5605	4	
Scenic 2 1.9 Dci	1.9	96	4	05.05-02.08	F9Q 804	12,0	Y-732J	5605	4	
Scenic 2 1.9 Dci	1.9	96	4	05.05-02.08	F9Q 816	12,0	Y-732J	5605	4	
Scenic 2 1.9 Dci	1.9	96	4	05.05-02.08	F9Q 818	12,0	Y-732J	5605	4	
Scenic 2 1.9 dCi	JM14, JM15, JM17, JM1D	1.9	97	4	10.05-12.09	F9Q804	12,0	Y-732J	5605	4
Scenic 2 2.0 -/dCi	JM1K	2.0	110	4	02.07-11.08	M9R700	7,0	CZ167	91063	91
Scenic 2 2.0 -/dCi	JM1K	2.0	110	4	02.07-11.08	M9R721	7,0	CZ167	91063	91
Scenic 2 2.0 -/dCi	JM1K	2.0	110	4	02.07-11.08	M9R722	7,0	CZ167	91063	91
Grand Scenic 2 2.0 -/dCi	JM1K	2.0	110	4	02.07-11.08	M9R700	7,0	CZ167	91063	91
Grand Scenic 2 2.0 -/dCi	JM1K	2.0	110	4	02.07-11.08	M9R721	7,0	CZ167	91063	91
Grand Scenic 2 2.0 -/dCi	JM1K	2.0	110	4	02.07-11.08	M9R722	7,0	CZ167	91063	91

SCENIC 3

Scenic 3 1.5 dCi	1.5	63	4	04.09-	K9K 830	4,4	Y1035AS	94103	77	
Scenic 3 1.5 dCi	1.5	70	4	11.10-	K9K 846	4,4	Y1035AS	94103	77	
Scenic 3 1.5 dCi	1.5	78	4	02.09-	K9K 832	4,4	Y1035AS	94103	77	
Scenic 3 1.5 dCi	1.5	81	4	04.09-	K9K 836	4,4	Y1035AS	94103	77	
Scenic 3 1.6 dCi	1.6	96	4	04.11-	R9M 402	4,5	Y1010AS	97618	88	
Scenic 3 1.6 dCi	1.6	96	4	04.11-	R9M 404	4,5	Y1010AS	97618	88	
Scenic 3 1.9 dCi	1.9	96	4	12.08-	F9Q 870	4,4	Y1036AS	96062		
Scenic 3 2.0 dCi	JZ0Y, JZ26	2.0	110	4	12.08-	M9R615	7,0	CZ167	91063	91
Grand Scenic 3 2.0 dCi	JZ0Y, JZ26	2.0	110	4	02.09-	M9R615	7,0	CZ167	91063	91
Scenic 3 2.0 dCi	JZ0L, JZ25	2.0	118	4	04.09-	M9R610	7,0	CZ167	91063	91
Grand Scenic 3 2.0 dCi	JZ0L, JZ25	2.0	118	4	04.09-	M9R610	7,0	CZ167	91063	91

SCENIC 4

Scenic 4 1.7 Blue dCi/dCi	R9A7, R9A8, J9A7, J9A8	1.7	88	4	08.18-	R9N401	4,5	Y1047AS	95340	
Scenic 4 1.7 Blue dCi/dCi	R9A7, R9A8, J9A7, J9A8	1.7	110	4	08.18-	R9N401	4,5	Y1047AS	95340	



e kW C
Y IStock-No
D-POWER**RENAULT****SCENIC PHASE II**

Scenic Phase 2 D		1.9	48	4	09.99-		11,0	Y-927J	4916	19
Scenic Phase 2 Dti		1.9	59	4	06.01-	F9Q T770	12,0	Y-732J	5605	4
Scenic Phase 2 Dti		1.9	74	4	09.99-	F9Q730, F9Q734, F9Q744	11,0	Y-740U	4818	22
Scenic Phase 2 Dti		1.9	74	4	09.99-	F9Q 734	11,0	Y-740U	4818	22
Scenic Phase 2 Dti		1.9	74	4	09.99-	F9Q 744	11,0	Y-740U	4818	22
Scenic Phase 2 Dci		1.9	77	4	03.99-	F9Q718, F9Q736, F9Q740	12,0	Y-732J	5605	4
Scenic Phase 2 Dci		1.9	77	4	03.99-	F9Q 731	12,0	Y-732J	5605	4
Scenic Phase 2 Dci RX4		1.9	77	4	09.00-	F9Q 740	12,0	Y-732J	5605	4

SCENIC PHASE IV

Scenic PHASE IV 1.6 dCi (color code: Yellow)	J9A4	1.6	96	4	09.16-	R9M409	4,5	Y1010AS	91210	88
Scenic PHASE IV 1.6 dCi (color code: Yellow)	J9A5	1.6	118	4	09.16-	R9M452	4,5	Y1010AS	91210	88

SCENIC XMOD

Scenic Xmod 1.6 dCi	JZ00, JZ12, JZ2A	1.6	96	4	06.13-	R9M402	4,5	Y1010AS	97618	88
Scenic Xmod 1.6 dCi	JZ00, JZ12, JZ2A	1.6	96	4	06.13-	R9M404	4,5	Y1010AS	97618	88

SYMBOL

Symbol 1.5 dCi	LB0, LB1, LB2	1.5	47	4	06.05-	K9K740	12,0	Y-732J	5605	4
Symbol 1.5 dCi	LB0, LB1, LB2	1.5	48	4	04.02-10.05	K9K700	12,0	Y-732J	5605	4
Symbol 1.5 dCi	LB0, LB1, LB2	1.5	50	4	02.03-	K9K700, K9K714	12,0	Y-732J	5605	4
Symbol 1.5 dCi	LB0, LB1, LB2	1.5	60	4	06.01-	K9K702	12,0	Y-732J	5605	4
Symbol 1.9 D	LB0, LB1, LB2	1.9	48	4	02.98-05.01	F8Q 630	11,0	Y-506J	2419	7

SYMBOL II

Symbol II 1.5 dCi	LU1, 2	1.5	47	4	09.08-	K9K 740	12,0	Y-732J	5605	4
Symbol II 1.5 dCi	LU1, 2	1.5	62	4	09.08-	K9K 718	12,0	Y-732J	5605	4

TALISMAN

Talisman 1.6 dCi (color code: Yellow)	LPA4, KPA4	1.6	96	4	11.15-	R9M409	4,5	Y1010AS	91210	88
Talisman 1.6 dCi (color code: Yellow)	LPA5, KPA5	1.6	118	4	11.15-	R9M452	4,5	Y1010AS	91210	88
Talisman 1.6 dCi (color code: Yellow)	LPA5	1.6	118	4	11.15-	R9M453	4,5	Y1010AS	91210	88
Talisman 1.7 Blue dCi	LPA7, KPA7	1.7	88	4	09.18-	R9N401	4,5	Y1047AS	95340	
Talisman 1.7 Blue dCi	LPA8, KPA8	1.7	110	4	09.18-	R9N401	4,5	Y1047AS	95340	
Talisman 2.0 Blue dCi	LPAM, KPAM	2.0	118	4	01.19-	M9R650	4,5	Y1047AS	95340	
Talisman 2.0 Blue dCi	LPAL, KPAL	2.0	147	4	01.19-	M9R650	4,5	Y1047AS	95340	

THALIA

Thalia 1.5 dCi	LB0, LB1, LB2	1.5	47	4	06.05-	K9K740	12,0	Y-732J	5605	4
Thalia 1.5 dCi	LU1, 2	1.5	47	4	09.08-	K9K 740	12,0	Y-732J	5605	4
Thalia 1.5 dCi	LB0, LB1, LB2	1.5	48	4	04.02-10.05	K9K700	12,0	Y-732J	5605	4
Thalia 1.5 dCi	LB0, LB1, LB2	1.5	50	4	02.03-	K9K700, K9K714	12,0	Y-732J	5605	4
Thalia 1.5 dCi	LB0, LB1, LB2	1.5	60	4	06.01-	K9K702	12,0	Y-732J	5605	4
Thalia 1.5 dCi	LU1, 2	1.5	62	4	09.08-	K9K 718	12,0	Y-732J	5605	4
Thalia 1.9 D	LB0, LB1, LB2	1.9	48	4	02.98-05.01	F8Q630	11,0	Y-506J	2419	7

TRAFIC

Trafic D T 1000		1.9	45	4	11.97-	F8Q600, F8Q606	11,0	Y-506J	2419	7
-----------------	--	-----	----	---	--------	----------------	------	--------	------	---





e kW C
y i



Stock-No
D-POWER™

RENAULT

TRAFIC

Trafic Dci		1.9	60	4	05.01-	F9Q 762		12,0	Y-732J	5605	4
Trafic 1.9 Dci		1.9	74	4	05.01-	F9Q 760		12,0	Y-732J	5605	4
Trafic D T800, T1000, T1200		2.1	43	4	09.80-10.97	J8S620, J8S758		11,0	Y-924J	7906	1
Trafic D P1000, P1200, 4x4		2.1	43	4	11.81-10.97	852, 720, 750		11,0	Y-924J	7906	1
Trafic D T 1000		2.1	56	4	11.97-	S8U758, S8U780, S8U782		11,5	Y-910J	3617	3
Trafic D		2.5	52	4	10.82-10.97	S8U		11,0	Y-208T	1250	
Trafic D		2.5	55	4	03.90-10.97	Sofim 8140		11,0	Y-924J	7906	1
Trafic 2.5 dCi 115		2.5	84	4	08.07-	G9U 630		11,0	Y-517J	91766	66
Trafic 2.5 dCi 135		2.5	99	4	03.03-	G9U 730		11,0	Y-517J	91766	66
Trafic 2.5 dCi 150		2.5	107	4	08.06-	G9U 630		11,0	Y-517J	91766	66

TRAFIC II

Trafic II 1.9 dCi	JL0B, FLOB, ELOB	1.9	59	4	04.01-07.03	F9Q762		12,0	Y-732J	5605	4
Trafic II 1.9 dCi	FLOC	1.9	75	4	01.06-	F9Q760		12,0	Y-732J	5605	4
Trafic II 2.0 dCi	JL00, JL01, JLOH, JLOM, JLOP, JLOS FLO0, FL01, FLOH, FLOM, FLOP, FLOS	2.0	66	4	02.07-12.11	M9R630		7,0	CZ167	91063	91
Trafic II 2.0 dCi	JL00, JL01, JLOH, JLOM, JLOP, JLOS FLO0, FL01, FLOH, FLOM, FLOP, FLOS ELO0, EL01, ELOH, ELOM, ELOP, ELOS	2.0	66	4	02.07-	M9R782		7,0	CZ167	91063	91
Trafic II 2.0 dCi	FLO0, FL01, FLOH, FLOM, FLOP, FLOS ELO0, EL01, ELOH, ELOM, ELOP, ELOS	2.0	66	4	02.07-	M9R780		7,0	CZ167	91063	91
Trafic II 2.0 dCi	JL00, JL01, JLOH, JLOM, JLOU ELO0, EL01, ELOH, ELOM	2.0	84	4	02.07-	M9R692		7,0	CZ167	91063	91
Trafic II 2.0 dCi	JL00, JL01, JLOH, JLOM, JLOU ELO0, EL01, ELOH, ELOM	2.0	84	4	02.07-	M9R780		7,0	CZ167	91063	91
Trafic II 2.0 dCi	JL00, JL01, JLOH, JLOM, JLOU ELO0, EL01, ELOH, ELOM	2.0	84	4	02.07-	M9R782		7,0	CZ167	91063	91
Trafic II 2.0 dCi	JL00, JL01, JLOH, JLOM, JLOU ELO0, EL01, ELOH, ELOM	2.0	84	4	02.07-	M9R786		7,0	CZ167	91063	91

TRAFIC III

Trafic III 1.6 dCi	FGMD, FGME	1.6	66	4	06.14-	R9M408		4,5	Y1010AS	97618	88
Trafic III 1.6 dCi	FGMD, FGME	1.6	85	4	06.14-	R9M408		4,5	Y1010AS	97618	88
Trafic III 1.6 dCi	JGMA, JGMB, JGMC	1.6	88	4	06.14-	R9M450		4,5	Y1010AS	97618	88
Trafic III 1.6 dCi	JGMA, JGMB, JGMC	1.6	103	4	06.14-	R9M450		4,5	Y1010AS	97618	88
Trafic III 2.0 dCi 120	JGMN, FGMN	2.0	88	4	06.19-	M9R710		4,5	Y1047AS	95340	





e kW C
Y I



Stock-No
D-POWER

RENAULT

TRAFIC III

Trafic III 2.0 dCi 145	JGML, EGML, FGML	2.0	107	4	06.19-	M9R710	4,5	Y1047AS	95340	
Trafic III 2.0 dCi 170	JGMM, EGMM, FGMM	2.0	125	4	06.19-	M9R710	4,5	Y1047AS	95340	

TRAFIC PHASE II

Trafic PHASE II 2.0 dCi/ dCi 90 (color code: Yellow)	FL00, FL01, FLOH, FLOM, FLOP, FLOS, JL00, JL01, JLOH, JLOM, JLOP, JLOS	2.0	66	4	08.06-	M9R692	4,5	Y1010AS	91210	88
Trafic PHASE II 2.0 dCi (color code: Yellow)	FL00, FL01, FLOH, FLOM, FLOP, FLOS, JL00, JL01, JLOH, JLOM, JLOP, JLOS	2.0	66	4	01.12-	M9R630	4,5	Y1010AS	91210	88
Trafic PHASE II 2.0 dCi (color code: Yellow)	EL00, EL01, ELOH, ELOM	2.0	84	4	08.06-	M9R630	4,5	Y1010AS	91210	88
Trafic PHASE II 2.0 dCi (color code: Yellow)	EL00, EL01, ELOH, ELOM	2.0	84	4	08.06-	M9R692	4,5	Y1010AS	91210	88
Trafic PHASE II 2.0 dCi (color code: Yellow)	EL00, EL01, ELOH, ELOM	2.0	84	4	08.06-	M9R780	4,5	Y1010AS	91210	88
Trafic PHASE II 2.0 dCi (color code: Yellow)	EL00, EL01, ELOH, ELOM	2.0	84	4	08.06-	M9R782	4,5	Y1010AS	91210	88
Trafic PHASE II 2.0 dCi (color code: Yellow)	EL00, EL01, ELOH, ELOM	2.0	84	4	08.06-	M9R786	4,5	Y1010AS	91210	88

TRAFIC PHASE III

Trafic PHASE III 1.6 dCi 95 (color code: Yellow)	FGMJ, FGMR	1.6	70	4	07.15-	R9M413	4,5	Y1010AS	91210	88
Trafic PHASE III 1.6 dCi 95 (color code: Yellow)	FGMJ, FGMR	1.6	70	4	07.15-	R9M415	4,5	Y1010AS	91210	88
Trafic PHASE III 1.6 dCi 120 (color code: Yellow)	EGMB, EGMC	1.6	88	4	06.14-	R9M450	4,5	Y1010AS	91210	88
Trafic PHASE III 1.6 dCi 120 (color code: Yellow)	FGMK	1.6	89	4	07.15-	R9M413	4,5	Y1010AS	91210	88
Trafic PHASE III 1.6 dCi 125 (color code: Yellow)	FGMH, EGMH	1.6	92	4	07.15-	R9M452	4,5	Y1010AS	91210	88
Trafic PHASE III 1.6 dCi 140 (color code: Yellow)	EGMA, EGMC	1.6	103	4	06.14-	R9M450	4,5	Y1010AS	91210	88
Trafic PHASE III 1.6 dCi 145 (color code: Yellow)	FGMG, EGMG	1.6	107	4	07.15-	R9M452	4,5	Y1010AS	91210	88

TWINGO

Twingo 1.5 dCi	CN0E, GNOE	1.5	47	4	03.07-09.14	K9K740	12,0	Y-732J	5605	4
Twingo 1.5 dCi	CN00, CN03	1.5	55	4	10.10-09.14	K9K820	4,4	Y1035AS	94103	77
Twingo 1.5 dCi	CN0U	1.5	62	4	04.08-09.14	K9K718	12,0	Y-732J	5605	4
Twingo 1.5 dCi	CN03	1.5	63	4	10.10-09.14	K9K820	4,4	Y1035AS	94103	77

VEL SATIS

Vel Satis 2.0 dCi	BJ03, BJ0B	2.0	110	4	02.07-08.09	M9R760	7,0	CZ167	91063	91
Vel Satis 2.0 dCi	BJ03, BJ0B	2.0	127	4	02.07-08.09	M9R762	7,0	CZ167	91063	91
Vel Satis 2.0 dCi	BJ03, BJ0B	2.0	127	4	02.07-08.09	M9R763	7,0	CZ167	91063	91
Vel Satis Dci	BJ0	2.2	85	4	03.02-12.03	G9T600	11,0	Y-517J	91766	66
Vel Satis 2.2 dCi	BJ00, BJ0E, BJ0F, BJ0G, BJ0H, BJ0M	2.2	102	4	06.02-08.09	G9T702	11,0	Y-517J	91766	66
Vel Satis 3.0 dCi	BJ0J, BJ0N	3.0	130	6	06.02-06.06	P9X701	11,0	CZ24	92070	
Vel Satis 3.0 dCi	BJ0S	3.0	133	6	06.06-08.09	P9X715	11,0	CZ24	92070	





l kW C
y i



Stock-No
D-POWER™

ROVER

115

115 SD/CSD	1.5	57	4	01.95- .98	TUD 5	11,0	Y-503J	1009	10
------------	-----	----	---	------------	-------	------	--------	------	----

217

217 SD, 218 SD/SLD	1.9	49	4	09.91-	XUD 9	11,0	Y-924J	7906	1
--------------------	-----	----	---	--------	-------	------	--------	------	---

218

218 TD	1.8	65	4	09.91-	XUD 7 TE	11,0	Y-924J	7906	1
--------	-----	----	---	--------	----------	------	--------	------	---

218 D	1.9	49	4	09.91-	XUD 9	11,0	Y-924J	7906	1
-------	-----	----	---	--------	-------	------	--------	------	---

220

220 SDi	2.0	63	4	10.95-	20 T2R	11,0	Y-730U	6704	17
---------	-----	----	---	--------	--------	------	--------	------	----

220 SDi	2.0	77	4	10.95-	20T2N (Intercooled)	11,0	Y-730U	6704	17
---------	-----	----	---	--------	---------------------	------	--------	------	----

2400

2400 TD			4	.82-		11,0	Y-924J	7906	1
---------	--	--	---	------	--	------	--------	------	---

25

25 2.0 iDT	2.0	74	4	11.99-		11,0	Y-730U	6704	17
------------	-----	----	---	--------	--	------	--------	------	----

418

418 SLD/GSD TD	1.8	65	4	09.91-03.96	XUD 7 T	11,0	Y-924J	7906	1
----------------	-----	----	---	-------------	---------	------	--------	------	---

420

420 SDi, SLDi TD	2.0		4	10.95- .99	20 T2R, 20T2N (Intercooled)	11,0	Y-730U	6704	17
------------------	-----	--	---	------------	-----------------------------	------	--------	------	----

420D

420 D / SD	2.0	63	4	07.95-		11,0	Y-730U	6704	17
------------	-----	----	---	--------	--	------	--------	------	----

420 Di / Sdi	2.0	77	4	07.95-		11,0	Y-730U	6704	17
--------------	-----	----	---	--------	--	------	--------	------	----

45

45 TD	2.0	73	4	11.99-		11,0	Y-730U	6704	17
-------	-----	----	---	--------	--	------	--------	------	----

620

620 SDi, SLDi TD	2.0		4	10.95- .99	20 T2R, 20T2N (Intercooled)	11,0	Y-730U	6704	17
------------------	-----	--	---	------------	-----------------------------	------	--------	------	----

75

75 2.0 CDT	2.0	85	4	.99-	M47R (BMW)	11,0	Y-507J	2691	32
------------	-----	----	---	------	------------	------	--------	------	----

75	2.0		4	02.99-	M47R (BMW)	11,0	Y-507J	2691	32
----	-----	--	---	--------	------------	------	--------	------	----

825

825 SD TD	2.5	87	4	01.93-	VM HR-492, VM 425 SLIRR	11,0	Y-924J	7906	1
-----------	-----	----	---	--------	-------------------------	------	--------	------	---

825 D/SD/SLD	2.5		4	.90-03.96	VM	11,0	Y-924J	7906	1
--------------	-----	--	---	-----------	----	------	--------	------	---

825	2.5		4	03.96-10.99	VM	11,0	Y-741U	6943	20
-----	-----	--	---	-------------	----	------	--------	------	----

90

90, 110 D			4	01.83-		11,0	Y-208T	1250	
-----------	--	--	---	--------	--	------	--------	------	--

FL 2

FL 2 / R (Hire Car) D				08.83-		11,0	Y-208T	1250	
-----------------------	--	--	--	--------	--	------	--------	------	--

FX 4R

FX 4R Taxi D				08.83-		11,0	Y-208T	1250	
--------------	--	--	--	--------	--	------	--------	------	--

MAESTRO

Maestro Van TD	2.0	60	4	01.86-		11,0	Y-924J	7906	1
----------------	-----	----	---	--------	--	------	--------	------	---

Maestro TD	2.0	60	4	07.89-	Perkins-Prima 80 T	11,0	Y-924J	7906	1
------------	-----	----	---	--------	--------------------	------	--------	------	---

METRO

Metro D	1.4	39	4	01.92-01.95	Peugeot TUD 3	11,5	Y-910J	3617	3
---------	-----	----	---	-------------	---------------	------	--------	------	---

MONTEGO

Montego TD	2.0	60	4	09.88-	Perkins-Prima 80 T	11,0	Y-924J	7906	1
------------	-----	----	---	--------	--------------------	------	--------	------	---





l kW
C
Y
I



Stock-No
D-POWER

ROVER

STREETWISE

Streetwise 2.0 TD	2,0		4	07.03-		11,0	Y-730U	6704	17
-------------------	-----	--	---	--------	--	------	--------	------	----

SAAB

9-3 1

9-3 2.2 TiD	YS3D	2,2	85	4	02.98-11.00	D223L, X22DTH Opel	11,0	Y-748U	6649	14
9-3 2.2 TiD	YS3D	2,2	92	4	11.00-09.02	D223L	11,0	Y-523J	6298	37

9-3 2

9-3 1.9 TiD	YS3F	1,9	88	4	03.05-07.12	Z19DT Fiat	11,0	Y-534J	3413	36
9-3 1.9 TTiD	YS3F	1,9	96	4	12.07-07.12	A19DTR	4,4	Y9003AS	94251	78
9-3 1.9 TiD	YS3F	1,9	110	4	03.05-07.12	Z19DTH	11,0	YE07	6092	
9-3 1.9 TTiD	YS3F	1,9	118	4	12.07-07.12	A19DTR	4,4	Y9003AS	94251	78
9-3 1.9 TTiD	YS3F	1,9	132	4	02.08-07.12	Z19DTR	4,4	Y9003AS	94251	78
9-3 2.2 TiD	YS3F	2,2	92	4	09.02-	D223L	11,0	Y-523J	6298	37

9-3X

9-3X 1.9 TTiD	YS3F	1,9	132	4	02.09-07.12	Z19DTR	4,4	Y9003AS	94251	78
---------------	------	-----	-----	---	-------------	--------	-----	---------	-------	----

9-5 1

9-5 1.9 TiD	YS3E	1,9	110	4	01.06-05.10	Z19DTH	11,0	YE07	6092	
9-5 2.2 TiD	YS3E	2,2	88	4	01.02-08.05	D223L	11,0	Y-748U	6649	14

SEAT

ALHAMBRA 1995

Alhambra 1.9 TDI	7V8, 7V9	1,9	66	4	04.95-07.96	1Z	12,0	Y-732J	5605	4
Alhambra 1.9 TDI	7V8, 7V9	1,9	66	4	07.96-02.00	AHU	12,0	Y-732J	5605	4
Alhambra 1.9 TDI	7V8, 7V9	1,9	81	4	09.97-02.00	AFN	12,0	Y-732J	5605	4

ALHAMBRA 2000

Alhambra 1.9 TDI	7V8, 7V9	1,9	66	4	06.00-03.10	ANU	12,0	Y-732J	5605	4
Alhambra 1.9 TDI	7V8, 7V9	1,9	85	4	06.00-03.10	AUY	12,0	Y-732J	5605	4
Alhambra 1.9 TDI	7V8, 7V9	1,9	96	4	11.02-11.08	ASZ	11,0	Y-741U	6943	20
Alhambra 1.9 TDI	7V8, 7V9	1,9	110	4	05.05-05.07	BTB	11,0	Y-741U	6943	20
Alhambra 2.0 TDI	7V8, 7V9	2,0	103	4	11.05-03.10	BRT	7,0	CZ104	9826	52

ALHAMBRA 2010

Alhambra 2.0 TDI	710	2,0	85	4	06.11-	CFFE	4,4	Y1002AS	8888	57
Alhambra 2.0 TDI	710	2,0	100	4	06.10-	CFFA	4,4	Y1002AS	8888	57
Alhambra 2.0 TDI	710	2,0	103	4	06.10-	CFFB	4,4	Y1002AS	8888	57
Alhambra 2.0 TDI	710	2,0	125	4	06.10-	CFGB	4,4	Y1002AS	8888	57
Alhambra 2.0 TDI	710	2,0	130	4	11.12-	CFGC	4,4	Y1002AS	8888	57

ALTEA

Altea 1.6 TDI	5P1	1,6	77	4	10.09-	CAYC	4,4	Y1002AS	8888	57
Altea 1.9 TDI	5P1	1,9	66	4	08.09-	BXF	5,0	Y-607AS	7560	50
Altea 1.9 TDI	5P1	1,9	77	4	04.04-09.05	BJB	5,0	Y-607AS	7560	50
Altea 1.9 TDI	5P1	1,9	77	4	04.04-05.06	BKC	5,0	Y-607AS	7560	50
Altea 1.9 TDI	5P1	1,9	77	4	10.05-	BLS	7,0	CZ104	9826	52
Altea 1.9 TDI	5P1	1,9	77	4	02.06-	BXE	5,0	Y-607AS	7560	50
Altea 2.0 TDI 16V	5P1	2,0	100	4	04.04-05.09	AZV	4,4	YE14	7768	48
Altea 2.0 TDI	5P5	2,0	103	4	03.04-	CFHC	4,4	Y1002AS	8888	57
Altea 2.0 TDI 16V	5P1	2,0	103	4	03.04-	BKD	4,4	YE14	7768	48



e kW C
y
iStock-No
D-POWER™**SEAT****ALTEA**

Altea 2.0 TDI	5P1	2.0	103	4	11.05-	BMM	5,0	Y-607AS	7560	50
Altea 2.0 TDI	5P1	2.0	125	4	02.06-	BMN	7,0	CZ304	9864	55
Altea 2.0 TDI	5P1	2.0	125	4	03.09-09.10	CEGA	4,4	Y-609AS	5849	49

ALTEA XL

Altea XL 1.6 TDI	5P5	1.6	77	4	10.09-	CAYC	4,4	Y1002AS	8888	57
Altea XL 2.0 TDI 16V 4x4	5P5	2.0	103	4	09.10-	CFHC	4,4	Y1002AS	8888	57

AROSA

Arosa 1.4 TDI (VIN→6H-2-009 700)	6H	1.4	55	3	09.99-06.04	AMF	12,0	Y-732J	5605	4
Arosa 1.4 TDI (VIN 6H-2-009 701→)	6H	1.4	55	3	09.99-06.04	AMF	11,0	Y-741U	6943	20
Arosa 1.7 SDI	6H	1.7	44	4	08.97-10.03	AKU	12,0	Y-732J	5605	4
Arosa 1.7 SDi (color code: Black)	6H1	1.7	44	4	08.97-10.03	AKU	12,0	Y-918J	6285	2

CORDOBA

Cordoba TDI		1.4	51	3	05.05-	BNM	11,0	Y-741U	6943	20
Cordoba TDI		1.4	55	3	10.02-04.04	AMF	11,0	Y-741U	6943	20
Cordoba TDI		1.4	58	3	05.05-	BNV	11,0	Y-741U	6943	20
Cordoba TDI PD		1.4	59	3	06.06-12.06	BMS	7,0	CZ104	9826	52
Cordoba / Vario D		1.9	47	4	02.93-	1Y	12,0	Y-918J	6285	2
Cordoba / Vario SDI		1.9	47	4	07.96-	AEY	12,0	Y-732J	5605	4
Cordoba SDI		1.9	47	4	09.02-04.04	ASY	12,0	Y-732J	5605	4
Cordoba SDI		1.9	50	4	04.99-08.02	AGP	12,0	Y-732J	5605	4
Cordoba SDI		1.9	50	4	06.99-08.02	AQM	12,0	Y-732J	5605	4
Cordoba / Vario TD		1.9	55	4	02.93-08.97	AAZ	12,0	Y-918J	6285	2
Cordoba / Vario TDI		1.9	66	4	07.95-12.96	1Z	12,0	Y-732J	5605	4
Cordoba / Vario TDI		1.9	66	4	12.96-	AHU	12,0	Y-732J	5605	4
Cordoba TDI		1.9	66	4	04.99-08.02	AGR	12,0	Y-732J	5605	4
Cordoba TDI		1.9	66	4	10.99-05.01	ALH	12,0	Y-732J	5605	4
Cordoba TDI		1.9	74	4	09.02-04.04	ATD	11,0	Y-741U	6943	20
Cordoba TDI		1.9	74	4	05.05-	AXR	11,0	Y-741U	6943	20
Cordoba TDI		1.9	74	4	09.06-12.06	BMT	7,0	CZ104	9826	52
Cordoba / Vario TDI		1.9	81	4	03.97-	AFN	12,0	Y-732J	5605	4
Cordoba TDI		1.9	81	4	03.99-08.02	ASV	12,0	Y-732J	5605	4
Cordoba TDI		1.9	96	4	10.02-04.04	ASZ	11,0	Y-741U	6943	20
Cordoba TDI		1.9	96	4	05.05-	BLT	11,0	Y-741U	6943	20

EXEO

Exeo 2.0 TDI	3R2, 3R5	2.0	88	4	12.08-05.13	CAGC	4,4	Y1002AS	8888	57
Exeo 2.0 TDI	3R2, 3R5	2.0	88	4	12.08-05.13	CJCC	4,4	Y1002AS	8888	57
Exeo 2.0 TDI	3R2, 3R5	2.0	105	4	12.08-05.13	CAGA	4,4	Y1002AS	8888	57
Exeo 2.0 TDI	3R2, 3R5	2.0	105	4	12.08-05.13	CJCA	4,4	Y1002AS	8888	57
Exeo 2.0 TDI	3R2, 3R5	2.0	125	4	02.09-05.13	CAHA	4,4	Y1002AS	8888	57
Exeo 2.0 TDI	3R2, 3R5	2.0	125	4	02.09-05.13	CGLB	4,4	Y1002AS	8888	57

IBIZA 1

Ibiza 1 1.7 D	021A	1.7	42	4	09.87-05.93	022A5000	11,0	Y-924J	7906	1
---------------	------	-----	----	---	-------------	----------	------	--------	------	---

IBIZA 2

Ibiza 2 1.9 D	6K1	1.9	47	4	02.93-08.96	1Y	12,0	Y-918J	6285	2
Ibiza 2 1.9 SDI	6K1	1.9	47	4	07.96-08.99	AEY	12,0	Y-732J	5605	4



e kW C
Y
IStock-No
D-POWER™**SEAT****IBIZA 2**

Ibiza 2 1.9 TD	6K1	1.9	55	4	02.93-08.96	AAZ	12,0	Y-918J	6285	2
Ibiza 2 1.9 TDI	6K1	1.9	66	4	07.96-12.96	1Z	12,0	Y-732J	5605	4
Ibiza 2 1.9 TDI	6K1	1.9	66	4	12.96-08.99	AHU	12,0	Y-732J	5605	4
Ibiza 2 1.9 TDI	6K1	1.9	81	4	03.97-08.99	AFN	12,0	Y-732J	5605	4

IBIZA 3

Ibiza 3 1.9 SDI	6K1	1.9	50	4	04.99-05.02	AGP	12,0	Y-732J	5605	4
Ibiza 3 1.9 SDI	6K1	1.9	50	4	05.99-05.02	AQM	12,0	Y-732J	5605	4
Ibiza 3 1.9 TDI	6K1	1.9	66	4	04.99-05.02	AGR	12,0	Y-732J	5605	4
Ibiza 3 1.9 TDI	6K1	1.9	66	4	05.99-05.02	ALH	12,0	Y-732J	5605	4
Ibiza 3 1.9 TDI	6K1	1.9	81	4	03.99-05.02	ASV	12,0	Y-732J	5605	4

IBIZA 4

Ibiza 4 1.4 TDI	6L1	1.4	51	3	05.05-11.09	BNM	11,0	Y-741U	6943	20
Ibiza 4 1.4 TDI (VIN 6L-2-001 501→)	6L1	1.4	55	3	05.05-12.05	AMF	11,0	Y-741U	6943	20
Ibiza 4 1.4 TDI	6L1	1.4	59	3	05.05-11.09	BNV	11,0	Y-741U	6943	20
Ibiza 4 1.9 SDI	6L1	1.9	47	4	05.05-12.05	ASY	12,0	Y-732J	5605	4
Ibiza 4 1.9 TDI	6L1	1.9	74	4	05.05-11.09	AXR	11,0	Y-741U	6943	20
Ibiza 4 1.9 TDI	6L1	1.9	74	4	05.05-05.05	ATD	11,0	Y-741U	6943	20
Ibiza 4 1.9 TDI	6L1	1.9	74	4	09.06-11.09	BMT	7,0	CZ104	9826	52
Ibiza 4 1.9 TDI	6L1	1.9	96	4	05.05-11.09	BLT	11,0	Y-741U	6943	20
Ibiza 4 1.9 TDI (VIN 6L-2-001 501→)	6L1	1.9	96	4	05.05-09.05	ASZ	11,0	Y-741U	6943	20
Ibiza 4 1.9 TDI Cupra R	6L1	1.9	118	4	03.04-02.08	BPX	11,0	Y-741U	6943	20
Ibiza 4 1.9 TDI Cupra R	6L1	1.9	118	4	11.05-02.08	BUK	11,0	Y-741U	6943	20

IBIZA 5

Ibiza 5 1.2 TDI	6J5	1.2	55	3	05.10-	CFWA	4,4	Y1002AS	8888	57
Ibiza 5 1.4 TDI	6J5	1.4	59	3	07.08-06.10	BMS	7,0	CZ104	9826	52
Ibiza 5 1.6 TDI	6J5	1.6	55	4	05.10-	CAYA	4,4	Y1002AS	8888	57
Ibiza 5 1.6 TDI	6J5	1.6	66	4	05.09-	CAYB	4,4	Y1002AS	8888	57
Ibiza 5 1.6 TDI	6J5	1.6	77	4	05.09-	CAYC, CLNA	4,4	Y1002AS	8888	57
Ibiza 5 1.9 TDI	6J5	1.9	66	4	06.08-06.10	BXJ	5,0	Y-607AS	7560	50
Ibiza 5 1.9 TDI	6J5	1.9	77	4	02.08-06.10	BLS	7,0	CZ104	9826	52
Ibiza 5 2.0 TDI	6J5	2.0	105	4	01.10-	CFHD	4,4	Y1002AS	8888	57

INCA

Inca D	6K9	1.7	42	4	07.96-09.00	AHB	12,0	Y-918J	6285	2
Inca SDI	6K9	1.9	47	4	11.95-09.00	AEY	12,0	Y-732J	5605	4
Inca D	6K9	1.9	47	4	11.95-06.03	1Y	12,0	Y-918J	6285	2
Inca SDI	6K9	1.9	47	4	09.00-06.03	AYQ	12,0	Y-732J	5605	4

LEÓN 1

León 1 1.9 SDI	1M1	1.9	50	4	03.00-10.03	AQM	12,0	Y-732J	5605	4
León 1 1.9 TDI	1M1	1.9	66	4	03.99-10.05	ALH	12,0	Y-732J	5605	4
León 1 1.9 TDI	1M1	1.9	66	4	04.99-09.02	AGR	12,0	Y-732J	5605	4
León 1 1.9 TDI	1M1	1.9	74	4	10.05-06.06	AXR	11,0	Y-741U	6943	20
León 1 1.9 TDI	1M1	1.9	81	4	10.98-09.02	AHF	12,0	Y-732J	5605	4
León 1 1.9 TDI	1M1	1.9	81	4	11.99-10.05	ASV	12,0	Y-732J	5605	4
León 1 1.9 TDI	1M1	1.9	96	4	05.03-06.06	ASZ	11,0	Y-741U	6943	20
León 1 1.9 TDI (VIN→1M-2-062000)	1M1	1.9	110	4	09.00-	ARL	12,0	Y-732J	5605	4





e kW C y l

Stock-No
D-POWER™**SEAT****LEÓN 1**

León 1 1.9 TDI (VIN 1M-2-062001->)	1M1	1.9	110	4	09.00-12.05	ARL	11,0	Y-741U	6943	20
------------------------------------	-----	-----	-----	---	-------------	-----	------	--------	------	----

LEÓN 2

León 2 1.6 TDI	1P1	1.6	77	4	02.10-	CAYC	4,4	Y1002AS	8888	57
León 2 1.9 TDI	1P1	1.9	66	4	06.07-	BXF	5,0	Y-607AS	7560	50
León 2 1.9 TDI	1P1	1.9	77	4	07.05-02.06	BKC	5,0	Y-607AS	7560	50
León 2 1.9 TDI	1P1	1.9	77	4	11.05-	BLS	7,0	CZ104	9826	52
León 2 1.9 TDI	1P1	1.9	77	4	02.06-	BXE	5,0	Y-607AS	7560	50
León 2 2.0 TDI	1P1	2.0	100	4	07.05-03.09	AZV	4,4	YE14	7768	48
León 2 2.0 TDI 16V	1P1	2.0	103	4	07.05-	BKD	4,4	YE14	7768	48
León 2 2.0 TDI	1P1	2.0	103	4	10.05-	BMM	5,0	Y-607AS	7560	50
León 2 2.0 TDI	1P1	2.0	125	4	05.06-03.09	BMN	7,0	CZ304	9864	55
León 2 2.0 TDI	1P1	2.0	125	4	03.09-09.10	CEGA	4,4	Y-609AS	5849	49

LEÓN 3

León 3 1.6 TDI (only for cyl. without pressure sensor; Euro 5)	5F1, 5F5, 5F8	1.6	66	4	11.12-	CLHB	4,4	Y1002AS	8888	57
León 3 1.6 TDI (only for cyl. without pressure sensor; Euro 5)	5F1, 5F5, 5F8	1.6	77	4	09.12-	CLHA	4,4	Y1002AS	8888	57
León 3 1.6 TDI (only for cyl. without pressure sensor)	5F1, 5F5, 5F8	1.6	81	4	09.13-	CRKB	4,4	Y1002AS	8888	57
León 3 2.0 TDI (only for cyl. without pressure sensor; Euro 5)	5F1, 5F5, 5F8	2.0	81	4	02.13-	CRVA	4,4	Y1002AS	8888	57
León 3 2.0 TDI (only for cyl. without pressure sensor; Euro 5)	5F1, 5F5, 5F8	2.0	105	4	05.13-	CRVC	4,4	Y1002AS	8888	57
León 3 2.0 TDI (only for cyl. without pressure sensor; Euro 5)	5F1, 5F5, 5F8	2.0	110	4	10.12-	CKFC	4,4	Y1002AS	8888	57
León 3 2.0 TDI (only for cyl. without pressure sensor; Euro 5)	5F1, 5F5, 5F8	2.0	110	4	10.12-	CRMB	4,4	Y1002AS	8888	57
León 3 2.0 TDI (only for cyl. without pressure sensor; Euro 5)	5F1, 5F5, 5F8	2.0	110	4	10.12-	CRBC	4,4	Y1002AS	8888	57
León 3 2.0 TDI (only for cyl. without pressure sensor; Euro 5)	5F1, 5F5, 5F8	2.0	110	4	10.12-	CRLB	4,4	Y1002AS	8888	57
León 3 2.0 TDI (only for cyl. without pressure sensor; Euro 5)	5F1, 5F5, 5F8	2.0	135	4	02.13-	CUPA	4,4	Y1002AS	8888	57
León 3 2.0 TDI (only for cyl. without pressure sensor; Euro 5)	5F1, 5F5, 5F8	2.0	135	4	03.13-	CUNA	4,4	Y1002AS	8888	57

MALAGA

Malaga D		1.7		4	09.87-08.91		11,0	Y-924J	7906	1
----------	--	-----	--	---	-------------	--	------	--------	------	---

TERRA

Terra Kombi D		1.4		4	10.91-	1W	12,0	Y-918J	6285	2
---------------	--	-----	--	---	--------	----	------	--------	------	---

TOLEDO 1

Toledo 1 1.9 D	1L	1.9	47	4	03.91-03.99	1Y	12,0	Y-918J	6285	2
Toledo 1 1.9 TD	1L	1.9	55	4	03.91-04.97	AAZ	12,0	Y-918J	6285	2
Toledo 1 1.9 TDI	1L	1.9	66	4	08.93-12.96	1Z	12,0	Y-732J	5605	4
Toledo 1 1.9 TDI	1L	1.9	81	4	12.96-03.99	AFN	12,0	Y-732J	5605	4

TOLEDO 2

Toledo 2 1.9 SDI	1M2	1.9	50	4	05.01-10.03	AQM	12,0	Y-732J	5605	4
Toledo 2 1.9 TDI	1M2	1.9	66	4	03.99-10.05	ALH	12,0	Y-732J	5605	4
Toledo 2 1.9 TDI	1M2	1.9	66	4	05.99-09.02	AGR	12,0	Y-732J	5605	4
Toledo 2 1.9 TDI	1M2	1.9	81	4	05.99-09.02	AHF	12,0	Y-732J	5605	4
Toledo 2 1.9 TDI	1M2	1.9	81	4	10.99-10.05	ASV	12,0	Y-732J	5605	4
Toledo 2 1.9 TDI	1M2	1.9	110	4	10.00-12.05	ARL	12,0	Y-732J	5605	4

TOLEDO 3

Toledo 3 1.9 TDI	5P2	1.9	77	4	09.04-09.05	BJB	5,0	Y-607AS	7560	50
------------------	-----	-----	----	---	-------------	-----	-----	---------	------	----





l kW C
Y I



Stock-No
D-POWER

SEAT

TOLEDO 3

Toledo 3 1.9 TDI	5P2	1.9	77	4	09.04-02.06	BKC	5,0	Y-607AS	7560	50
Toledo 3 1.9 TDI	5P2	1.9	77	4	10.05-05.09	BLS	7,0	CZ104	9826	52
Toledo 3 1.9 TDI	5P2	1.9	77	4	02.06-05.09	BXE	5,0	Y-607AS	7560	50
Toledo 3 2.0 TDI	5P2	2.0	100	4	09.04-05.09	AZV	4,4	YE14	7768	48
Toledo 3 2.0 TDI 16V	5P2	2.0	103	4	04.04-05.09	BKD	4,4	YE14	7768	48
Toledo 3 2.0 TDI	5P2	2.0	103	4	11.05-05.09	BMM	5,0	Y-607AS	7560	50
Toledo 3 2.0 TDI	5P2	2.0	125	4	01.06-05.09	BMN	7,0	CZ304	9864	55
Toledo 3 2.0 TDI	5P2	2.0	125	4	03.09-05.09	CEGA	4,4	Y-609AS	5849	49

TOLEDO 4

Toledo 4 1.6 TDI	KG3	1.6	77	4	10.12-	CAYC	4,4	Y1002AS	8888	57
Toledo 4 1.6 TDI	KG3	1.6	77	4	10.12-	CLNA	4,4	Y1002AS	8888	57

SKODA

FABIA 1

Fabia 1 1.4 TDI	6Y2, 6Y5	1.4	55	3	04.03-10.05	AMF	11,0	Y-741U	6943	20
Fabia 1 1.9 SDI	6Y2, 6Y5	1.9	47	4	11.99-03.08	ASY	12,0	Y-732J	5605	4
Fabia 1 1.9 TDI	6Y2, 6Y5	1.9	74	4	01.00-10.05	ATD →6Y-2-451087	12,0	Y-732J	5605	4
Fabia 1 1.9 TDI	6Y2, 6Y5	1.9	74	4	01.00-10.05	ATD 6Y-2-451088 →	11,0	Y-741U	6943	20
Fabia 1 1.9 TDI	6Y2, 6Y5	1.9	74	4	10.05-12.07	AXR	11,0	Y-741U	6943	20
Fabia 1 1.9 TDI RS	6Y2	1.9	96	4	06.03-10.05	ASZ	11,0	Y-741U	6943	20
Fabia 1 1.9 TDI RS	6Y2	1.9	96	4	10.05-04.07	BLT	11,0	Y-741U	6943	20

FABIA 2

Fabia 2 1.2 TDI	542, 545	1.2	55	3	03.10-	CFWA	4,4	Y1002AS	8888	57
Fabia 2 1.2 TDI	542, 545	1.2	55	4	03.10-	CFWA	4,4	Y1002AS	8888	57
Fabia 2 1.4 TDI	542, 545	1.4	51	3	10.05-03.10	BNM	11,0	Y-741U	6943	20
Fabia 2 1.4 TDI	542, 545	1.4	59	3	10.05-03.10	BNV	11,0	Y-741U	6943	20
Fabia 2 1.4 TDI	542, 545	1.4	59	3	01.07-03.10	BMS	7,0	CZ104	9826	52
Fabia 2 1.6 TDI	542, 545	1.6	55	4	04.10-	CAYA	4,4	Y1002AS	8888	57
Fabia 2 1.6 TDI	542, 545	1.6	66	4	03.10-	CAYB	4,4	Y1002AS	8888	57
Fabia 2 1.6 TDI	542, 545	1.6	77	4	03.10-	CAYC	4,4	Y1002AS	8888	57
Fabia 2 1.9 TDI	542, 545	1.9	77	4	04.07-03.10	BLS	7,0	CZ104	9826	52
Fabia 2 1.9 TDI	542, 545	1.9	77	4	04.07-03.10	BSW	11,0	Y-741U	6943	20

FABIA 3

Fabia 3 1.4 TDI (only for cyl. without pressure sensor)	NJ3, NJ5	1.4	66	3	10.14-	CUSB	4,4	Y1002AS	8888	57
Fabia 3 1.4 TDI (only for cyl. without pressure sensor)	NJ3, NJ5	1.4	77	3	10.14-	CUTA	4,4	Y1002AS	8888	57

FELICIA

Felicia D		1.9	47	4	10.95-08.01	AEF	12,0	Y-918J	6285	2
Felicia D		1.9	47	4	.97-	AEY	12,0	Y-732J	5605	4

OCTAVIA

Octavia TDI		1.6	77	4	06.09-	CAYC	4,4	Y1002AS	8888	57
Octavia TD	SK	1.9	50	4	.97-		12,0	Y-918J	6285	2

OCTAVIA 1

Octavia 1 1.9 SDI	1U2, 1U5	1.9	47	4	09.96-	AEY	12,0	Y-732J	5605	4
Octavia 1 1.9 SDI	1U2, 1U5	1.9	50	4	05.97-12.03	AGP	12,0	Y-732J	5605	4
Octavia 1 1.9 SDI	1U2, 1U5	1.9	50	4	08.00-12.03	AQM	12,0	Y-732J	5605	4



e kW C
iStock-No
D-POWER™**SKODA****OCTAVIA 1**

Octavia 1 1.9 TDI	1U2, 1U5	1.9	66	4	10.96-03.10	AGR	12,0	Y-732J	5605	4
Octavia 1 1.9 TDI	1U2, 1U5	1.9	66	4	.97-	1Z	12,0	Y-732J	5605	4
Octavia 1 1.9 TDI	1U2, 1U5	1.9	66	4	08.00-03.10	ALH	12,0	Y-732J	5605	4
Octavia 1 1.9 TDI 4x4	1U5	1.9	74	4	08.00-01.06	ATD	12,0	Y-732J	5605	4
Octavia 1 1.9 TDI (VIN→1U-22598796; VIN→1U-28558122)	1U2, 1U5	1.9	74	4	10.05-12.10	AXR	12,0	Y-732J	5605	4
Octavia 1 1.9 TDI (VIN 1U-22598797→; VIN 1U-28558123→)	1U2, 1U5	1.9	74	4	10.05-12.10	AXR	11,0	Y-741U	6943	20
Octavia 1 1.9 TDI	1U2, 1U5	1.9	81	4	08.97-01.06	AHF	12,0	Y-732J	5605	4
Octavia 1 1.9 TDI	1U2, 1U5	1.9	81	4	.97-	AFN	12,0	Y-732J	5605	4
Octavia 1 1.9 TDI	1U2, 1U5	1.9	81	4	10.00-01.06	ASV	12,0	Y-732J	5605	4
Octavia 1 1.9 TDI	1U2, 1U5	1.9	96	4	09.02-09.04	ASZ	11,0	Y-741U	6943	20

OCTAVIA 2

Octavia 2 1.6 TDI	1Z3, 1Z5	1.6	77	4	06.09-	CAYC	4,4	Y1002AS	8888	57
Octavia 2 1.9 TDI	1Z3, 1Z5	1.9	77	4	05.04-12.10	BJB	5,0	Y-607AS	7560	50
Octavia 2 1.9 TDI	1Z3, 1Z5	1.9	77	4	05.04-02.06	BKC	5,0	Y-607AS	7560	50
Octavia 2 1.9 TDI	1Z3, 1Z5	1.9	77	4	03.06-12.10	BXE	5,0	Y-607AS	7560	50
Octavia 2 1.9 TDI	1Z3, 1Z5	1.9	77	4	05.06-12.10	BLS	5,0	Y-607AS	7560	50
Octavia 2 2.0 TDI	1Z3, 1Z5	2.0	81	4	03.10-06.13	CFHF	4,4	Y1002AS	8888	57
Octavia 2 2.0 TDI	1Z3, 1Z5	2.0	81	4	03.10-06.13	CLCA	4,4	Y1002AS	8888	57
Octavia 2 2.0 TDI	1Z3, 1Z5	2.0	100	4	05.04-10.08	AZV	4,4	YE14	7768	48
Octavia 2 2.0 TDI 16V	1Z3, 1Z5	2.0	100	4	05.04-	BKD	4,4	YE14	7768	48
Octavia 2 2.0 TDI	1Z3, 1Z5	2.0	103	4	01.06-05.10	BMM	5,0	Y-607AS	7560	50
Octavia 2 2.0 TDI 16V	1Z3, 1Z5	2.0	103	4	02.10-	CLCB	4,4	Y1002AS	8888	57
Octavia 2 2.0 TDI 16V	1Z3, 1Z5	2.0	103	4	03.10-	CFHC	4,4	Y1002AS	8888	57
Octavia 2 2.0 TDI RS	1Z3, 1Z5	2.0	125	4	04.06-05.08	BMN	7,0	CZ304	9864	55
Octavia 2 2.0 TDI RS	1Z3, 1Z5	2.0	125	4	04.06-	CEGA	4,4	Y1002AS	8888	57
Octavia 2 2.0 TDI RS	1Z3, 1Z5	2.0	125	4	06.08-	BMN	4,4	Y1002AS	8888	57

OCTAVIA 3

Octavia 3 1.6 TDI (only for cyl. without pressure sensor)	5E3, 5E5	1.6	66	4	11.12-	CLHB	4,4	Y1002AS	8888	57
Octavia 3 1.6 TDI (only for cyl. without pressure sensor)	5E3, 5E5	1.6	66	4	11.12-	CRKA	4,4	Y1002AS	8888	57
Octavia 3 1.6 TDI (only for cyl. without pressure sensor)	5E3, 5E5	1.6	77	4	11.12-	CLHA	4,4	Y1002AS	8888	57
Octavia 3 1.6 TDI (only for cyl. without pressure sensor)	5E3, 5E5	1.6	81	4	05.13-	CRKB	4,4	Y1002AS	8888	57
Octavia 3 2.0 TDI (only for cyl. without pressure sensor)	5E3, 5E5	2.0	105	4	11.12-	CKFB	4,4	Y1002AS	8888	57
Octavia 3 2.0 TDI (only for cyl. without pressure sensor)	5E3, 5E5	2.0	105	4	11.12-	CRVC	4,4	Y1002AS	8888	57
Octavia 3 2.0 TDI (only for cyl. without pressure sensor)	5E3, 5E5	2.0	110	4	11.12-	CKFC	4,4	Y1002AS	8888	57
Octavia 3 2.0 TDI RS (only for cyl. with- out pressure sensor)	5E3, 5E5	2.0	135	4	06.13-	CUNA	4,4	Y1002AS	8888	57
Octavia 3 2.0 TDI RS (only for cyl. with- out pressure sensor)	5E3, 5E5	2.0	135	4	06.13-	CUPA	4,4	Y1002AS	8888	57

PICKUP

Pickup		1.9	47	4	.97-	AEY	12,0	Y-732J	5605	4
--------	--	-----	----	---	------	-----	------	--------	------	---

RAPID 2012

Rapid 1.6 TDI	NH1, NH3	1.6	66	4	10.12-	CAYB	4,4	Y1002AS	8888	57
Rapid 1.6 TDI	NH1, NH3	1.6	77	4	07.12-	CAYC	4,4	Y1002AS	8888	57





€ kW C
y
i



Stock-No
D-POWER

SKODA

ROOMSTER

Roomster TDI	5J	1.2	55	3	03.10-	CFWA	4,4	Y1002AS	8888	57
Roomster TDI	5J	1.4	50	3	07.06-	BNM	11,0	Y-741U	6943	20
Roomster TDI	5J	1.4	59	3	05.06-	BNV	11,0	Y-741U	6943	20
Roomster TDI	5J	1.4	59	3	07.06-	BMS	7,0	CZ104	9826	52
Roomster TDI	5J	1.6	66	4	03.10-	CAYB	4,4	Y1002AS	8888	57
Roomster TDI	5J	1.6	77	4	03.10-	CAYC	4,4	Y1002AS	8888	57
Roomster TDI	5J	1.9	74	4	03.06-05.06	AXR	11,0	Y-741U	6943	20
Roomster TDI	5J	1.9	77	4	05.06-	BSW	11,0	Y-741U	6943	20
Roomster TDI	5J	1.9	77	4	11.06-	BLS	7,0	CZ104	9826	52

SUPERB 1

Superb 1 1.9 TDI	3U4	1.9	74	4	06.02-10.05	AVB	11,0	Y-741U	6943	20
Superb 1 1.9 TDI	3U4	1.9	77	4	10.05-05.07	BSV	7,0	CZ104	9826	52
Superb 1 1.9 TDI	3U4	1.9	85	4	01.07-03.08	BPZ	7,0	CZ104	9826	52
Superb 1 1.9 TDI	3U4	1.9	96	4	10.01-03.08	AWX	11,0	Y-741U	6943	20
Superb 1 1.9 TDI	3U4	1.9	96	4	01.04-03.08	AVF	11,0	Y-741U	6943	20
Superb 1 2.0 TDI	3U4	2.0	103	4	10.05-03.08	BSS	7,0	CZ104	9826	52
Superb 1 2.5 V6 TDI	3U4	2.5	114	6	12.01-08.03	AYM	11,0	Y-501U	4187	31
Superb 1 2.5 V6 TDI	3U4	2.5	120	6	06.03-03.08	BDG	11,0	Y-501U	4187	31

SUPERB 2

Superb 2 1.9 TDI	3T4, 3T5	1.9	77	4	03.08-	BXE	5,0	Y-607AS	7560	50
Superb 2 1.9 TDI	3T4, 3T5	1.9	77	4	07.08-	BLS	5,0	Y-607AS	7560	50
Superb 2 2.0 TDI	3T4, 3T5	2.0	103	4	03.08-03.10	BMP	7,0	CZ104	9826	52
Superb 2 2.0 TDI (VIN No 3T-99006001- ->)	3T4, 3T5	2.0	103	4	03.08-03.10	BMP	7,0	CZ104	9826	52
Superb 2 2.0 TDI (VIN No-> >3T-99006000)	3T4, 3T5	2.0	103	4	03.08-03.10	BMP	7,0	CZ104	9826	52
Superb 2 2.0 TDI	3T4, 3T5	2.0	103	4	01.09-	CFFB	4,4	Y1002AS	8888	57
Superb 2 2.0 TDI	3T4, 3T5	2.0	103	4	01.09-	CLJA	4,4	Y1002AS	8888	57
Superb 2 2.0 TDI	3T4, 3T5	2.0	103	4	01.09-	BKD	4,4	YE14	7768	48
Superb 2 2.0 TDI	3T4, 3T5	2.0	125	4	06.08-05.10	CBBB	4,4	Y1002AS	8888	57
Superb 2 2.0 TDI	3T4, 3T5	2.0	125	4	05.10-	CFGB	4,4	Y1002AS	8888	57

YETI (5L)

Yeti 1.6 TDI	5L	1.6	77	4	11.10-	CAYC	4,4	Y1002AS	8888	57
Yeti 2.0 TDI	5L	2.0	81	4	11.09-	CFHA	4,4	Y1002AS	8888	57
Yeti 2.0 TDI 4x4	5L	2.0	81	4	11.09-	CFHF	4,4	Y1002AS	8888	57
Yeti 2.0 TDI	5L	2.0	103	4	05.09-11.09	CBDB	4,4	Y1002AS	8888	57
Yeti 2.0 TDI	5L	2.0	103	4	11.09-	CFHC	4,4	Y1002AS	8888	57
Yeti 2.0 TDI 4x4	5L	2.0	125	4	11.09-05.10	CEGA	4,4	Y1002AS	8888	57
Yeti 2.0 TDI 4x4	5L	2.0	125	4	11.09-	CFJA	4,4	Y1002AS	8888	57

SMART

SMART

Smart CDI	450	0.8	29	3	07.98-01.04	OM 660 DE 08 LA	11,0	Y-543J	5618	46
-----------	-----	-----	----	---	-------------	-----------------	------	--------	------	----

SMART 450

Smart fortwo Cdi	450	0.8	30	3	01.04-01.07	OM 660	11,0	Y-543J	5618	46
------------------	-----	-----	----	---	-------------	--------	------	--------	------	----

SMART 451

Smart fortwo 2 Cdi	451	0.8	33	3	03.07-	OM 660.950	11,0	Y-543J	5618	46
--------------------	-----	-----	----	---	--------	------------	------	--------	------	----





e kW
C
y
i



Stock-No
D-POWER

SMART

SMART 451

Smart fortwo 2 Cdi	451	0.8	40	3	01.09-08.14	OM 660.951	7,0	CZ158	94171	
--------------------	-----	-----	----	---	-------------	------------	-----	-------	-------	--

SMART 454

Smart forfour 1 Cdi	454	1.5	50	3	09.04-06.06	OM 639.939	11,5	YE13	8643	
Smart forfour 1 Cdi	454	1.5	70	3	09.04-06.06	OM 639.939	11,5	YE13	8643	

SSANGYONG

ACTYON

Actyon 200 Xdi		2.0	100	4	07.07-	D20DT	11,0	Y-536J	95061	81
Actyon Sports 200 Xdi		2.0	104	4	10.06-	D20DT	11,0	Y-536J	95061	81
Actyon 200xdi		2.0	104	4	11.06-	D20DT	11,5	Y-745U	6346	11

KORANDO

Korando 2.2 D		2.2	51	4	01.93-12.96	DC 23	11,0	Y-710J	7880	
Korando 2.3 D		2.3	55	4	03.97-	OM 601 DM	11,5	Y-916J	5906	6
Korando 2.3 TD		2.3	73	4	03.99-03.00		11,5	Y-916J	5906	6
Korando 2.9 D		2.9	73	5	12.96-	MB-OM 602	11,5	Y-916J	5906	6
Korando 2.9 TD		2.9	88	5	03.99-03.00		11,5	Y-916J	5906	6

KYRON

Kyron 2.0 Xdi		2.0	100	4	01.10-	D20DT	11,0	Y-536J	95061	81
Kyron 2.0 Xdi		2.0	104	4	05.05-	D20DT	11,0	Y-536J	95061	81
Kyron 2.7 Xdi		2.7	120	5	03.06-	D27DT	11,0	Y-536J	95061	81
Kyron 2.7 Xdi		2.7	121	5	05.05-	D27DT	11,0	Y-536J	95061	81

MUSO

Musso 2.3 D		2.3	58	4	07.93-01.00	MB-OM 601	11,5	Y-916J	5906	6
Musso 2.3 TD		2.3	73	4	03.99-03.00		11,5	Y-916J	5906	6
Musso 2.9 D		2.9	73	5	07.93-01.00	MB-OM 602	11,5	Y-916J	5906	6
Musso 2.9 TD		2.9	88	5	03.99-		11,5	Y-916J	5906	6
Musso Sports 2.9 TD		2.9	88	5	03.04-		11,5	Y-916J	5906	6

REXTON

Rexton 2.7 Xdi 4x4		2.7	118	5	03.11-	D27DT	11,0	Y-536J	95061	81
Rexton 2.7 Xdi		2.7	120	5	07.04-	D27DT	11,0	Y-536J	95061	81
Rexton 2.7 Xdi (Glow plug for 11Volt)		2.7	121	5	03.05-08.06	D27DT	11,0	Y-536J	95061	81
Rexton 2.7 Xdi (Glow plug for 5.5Volt)		2.7	121	5	03.05-08.06	D27DT	5,0	Y-537AS	9994	
Rexton 2.7 Xdi Turbo 4x4		2.7	132	5	03.11-	D27DTP	11,0	Y-536J	95061	81
Rexton 2.7 D 4x4 (Glow plug for 11Volt)		2.7	137	5	05.06-	D27DTP	11,0	Y-536J	95061	81
Rexton 2.7 D 4x4 (Glow plug for 5.5Volt)		2.7	137	5	05.06-	D27DTP	5,0	Y-537AS	9994	

RODIUS

Rodius 2.7 Xdi		2.7	120	5	05.05-	D27DT	11,0	Y-536J	95061	81
Rodius 2.7 Xdi		2.7	121	5	05.05-	D27DT	11,0	Y-536J	95061	81

STEYR

290

Puch 290 GD		2.9	72	5	08.93-	OM602	11,5	Y-916J	5906	6
-------------	--	-----	----	---	--------	-------	------	--------	------	---

300

Puch 300 GD		3.0	83	6	09.89-	OM617, 603	11,5	Y-916J	5906	6
-------------	--	-----	----	---	--------	------------	------	--------	------	---

350

Puch 350 GTD		3.5	100	6	09.91-	OM617, 603	11,5	Y-916J	5906	6
--------------	--	-----	-----	---	--------	------------	------	--------	------	---





kw
C
y
i



Stock-No
D-POWER

SUBARU

FORESTER

Forester 2.0 Tdi	S12SH	2.0	108	4	09.08-09.13	EE20Z	11,0	Y-606J	92828	
------------------	-------	-----	-----	---	-------------	-------	------	--------	-------	--

IMPREZA

Impreza 2.0 TDi	G12GH	2.0	80	4	01.09-02.10	EE20Z	11,0	Y-606J	92828	
-----------------	-------	-----	----	---	-------------	-------	------	--------	-------	--

Impreza 2.0 TDi	G12GH	2.0	110	4	01.09-02.10	EE20Z	11,0	Y-606J	92828	
-----------------	-------	-----	-----	---	-------------	-------	------	--------	-------	--

LEGACY IV

Legacy 2.0 TDi	B13BL, B13BP	2.0	110	4	02.08-12.09	EE20Z	11,0	Y-606J	92828	
----------------	-----------------	-----	-----	---	-------------	-------	------	--------	-------	--

OUTBACK

Outback 2.0 TDi	B13BP	2.0	110	4	09.08-04.09	EE20Z	11,0	Y-606J	92828	
-----------------	-------	-----	-----	---	-------------	-------	------	--------	-------	--

SUZUKI

BALENO

Baleno D		1.9	46	4	.98-		11,0	Y-924J	7906	1
----------	--	-----	----	---	------	--	------	--------	------	---

Baleno TD		1.9	55	4	.98-		11,0	Y-924J	7906	1
-----------	--	-----	----	---	------	--	------	--------	------	---

GRAND VITARA

Grand Vitara 1.9 DDIS	JB419D	1.9	95	4	10.05-	F9Q	12,0	Y-732J	5605	4
-----------------------	--------	-----	----	---	--------	-----	------	--------	------	---

Grand Vitara 1.9 DDIS (Euro 5)	JT	1.9	95	4	03.06-08.08	F9QB	4,4	Y1036AS	96062	
--------------------------------	----	-----	----	---	-------------	------	-----	---------	-------	--

Grand Vitara TDiC	SQ420D	2.0	64	4	05.00-	RF	11,0	Y-701J	1566	39
-------------------	--------	-----	----	---	--------	----	------	--------	------	----

Grand Vitara Tdi II	SQ420D	2.0	80	4	03.01-	RHZ	11,0	Y-504J	1441	24
---------------------	--------	-----	----	---	--------	-----	------	--------	------	----

Grand Vitara TD XL7	JA420D	2.0	80	4	.04-	RHW	11,0	Y-504J	1441	24
---------------------	--------	-----	----	---	------	-----	------	--------	------	----

Grand Vitara D		2.0	81	4	04.01-	HDi PSA	11,0	Y-504J	1441	24
----------------	--	-----	----	---	--------	---------	------	--------	------	----

IGNIS II

Ignis II 1.3 DDiS	RM413D	1.3	51	4	09.03-	Z13DT	11,0	Y8003J	97256	62
-------------------	--------	-----	----	---	--------	-------	------	--------	-------	----

JIMNY

Jimny DDiS	SN415D	1.5	48	4	12.03-	K9K	12,0	Y-732J	5605	4
------------	--------	-----	----	---	--------	-----	------	--------	------	---

Jimny DDiS	SN415D	1.5	63	4	08.05-	K9K 266	12,0	Y-732J	5605	4
------------	--------	-----	----	---	--------	---------	------	--------	------	---

LIANA

Liana DDiS	RH414D	1.4	66	4	07.04-	DV4 8HY	11,0	YE04	1684	40
------------	--------	-----	----	---	--------	---------	------	------	------	----

SAMURAI

Samurai TD		1.9	46	4	09.98-	XUD9	11,0	Y-924J	7906	1
------------	--	-----	----	---	--------	------	------	--------	------	---

SPLASH

Splash 1.3 DDiS	A5B413D	1.3	55	4	01.08-	D13A	11,0	Y8003J	97256	62
-----------------	---------	-----	----	---	--------	------	------	--------	-------	----

SWIFT III

Swift III 1.3 DDiS	RS413D	1.3	52	4	08.05-	Z13DT	11,0	Y8003J	97256	62
--------------------	--------	-----	----	---	--------	-------	------	--------	-------	----

Swift III 1.3 DDiS	RS413D	1.3	55	4	10.07-	D13A, Z13DTJ	11,0	Y8003J	97256	62
--------------------	--------	-----	----	---	--------	--------------	------	--------	-------	----

SX4 I

SX4 I 1.9 DDiS	RW419D	1.9	88	4	06.06-	D19AA	11,0	Y1030J	90828	70
----------------	--------	-----	----	---	--------	-------	------	--------	-------	----

SX4 I 2.0 DDiS	RW420D	2.0	99	4	07.09-	D20AA	4,4	Y9003AS	94251	78
----------------	--------	-----	----	---	--------	-------	-----	---------	-------	----

SX4 II

SX4 II 1.6 DDiS S-Cross	AKK416D	1.6	88	4	08.13-	D16AA	4,4	Y9003AS	94251	78
-------------------------	---------	-----	----	---	--------	-------	-----	---------	-------	----

VITARA

Vitara TD		1.9	50	4	04.96-03.98	XUD9A	11,0	Y-924J	7906	1
-----------	--	-----	----	---	-------------	-------	------	--------	------	---

Vitara TD		1.9	55	4	.97- .98		11,0	Y-924J	7906	1
-----------	--	-----	----	---	----------	--	------	--------	------	---

Vitara TD		1.9	66	4	05.00-	XUD... PSA Group	11,0	Y-924J	7906	1
-----------	--	-----	----	---	--------	------------------	------	--------	------	---

Vitara D		2.0	52	4	12.94-03.98	RFL-4	11,0	Y-701J	1566	39
----------	--	-----	----	---	-------------	-------	------	--------	------	----





e kW y i

Stock-No
D-POWER™**SUZUKI****WAGON**

Wagon R+ DDiS	RB413D	1.3	51	4	09.03-	Z13DT	11,0	Y8003J	97256	62
---------------	--------	-----	----	---	--------	-------	------	--------	-------	----

TALBOT**EXPRESS**

Express D		1.9	51	4	11.87-	XUD 9 A	11,0	Y-924J	7906	1
Express D		2.5	55	4	09.81-10.93	CRD 93	11,0	Y-208T	1250	
Express TD		2.5	70	4	09.81-10.93	CRD 93 LS	11,0	Y-208T	1250	

HORIZON

Horizon D		1.9	51	4	11.87-	XUD9A	11,0	Y-924J	7906	1
-----------	--	-----	----	---	--------	-------	------	--------	------	---

TOYOTA**4 RUNNER**

4 Runner TD		2.4		4	01.90-12.96	2LT	11,0	Y-715R	5376	
4 Runner D		2.5		4	01.93-	2LT	11,0	Y-715R	5376	
4 Runner D		2.8		4	01.93- .96	3L	11,0	Y-715R	5376	
4 Runner		2.8		4	.93- .96	3L	11,0	Y-715R	5376	
4 Runner	KZN130_, KZN185	3.0	92	4	10.93-03.96	1KZT	11,0	Y1013J	94470	63

AURIS I

Auris I 1.4 D-4D	ADE150, ADE157, NDE150, NDE151	1.4	66	4	03.07-09.12	1ND-TV	11,0	Y-542J	5513	45
Auris I 2.0 D-4D	ADE150	2.0	93	4	10.06-09.12	1ADFTV	11,0	Y1012J	92083	65
Auris I 2.2 D-4D	ADE157	2.2	130	4	02.07-09.12	2ADFHV	11,0	Y1012J	92083	65

AVENSIS

Avensis	CT220	2.0	66	4	01.98-	2C-T	11,0	Y-532J	7782	
Avensis	CT220	2.0	66	4	01.98-	2C-TE	11,0	Y-532J	7782	
Avensis	CDT220, CDT250	2.0	81	4	08.99-01.03	1CD-FTV	11,0	Y-531J	5467	44

AVENSIS 2

Avensis 2 D- Cat	CDT250	2.0	85	4	03.03-04.06	1CD-FTV	11,0	Y-531J	5467	44
Avensis 2 2.0 D-4D	ADT250, ADT270	2.0	93	4	03.06-10.18	1ADFTV	11,0	Y1012J	92083	65
Avensis 2 2.2 D-4D	ADT251	2.2	110	4	04.05-10.08	2ADFTV	11,0	Y1012J	92083	65
Avensis 2 2.2 D-4D	ADT251	2.2	130	4	04.05-10.08	2ADFHV	11,0	Y1012J	92083	65

AVENSIS 3

Avensis 3 2.0 D-4D	ADT270	2.0	91	4	11.11-10.18	1ADFTV	11,0	Y1012J	92083	65
Avensis 3 2.2 D-4D	ADT271	2.2	110	4	02.09-10.18	2ADFTV	11,0	Y1012J	92083	65
Avensis 3 2.2 D-4D	ADT271	2.2	130	4	02.09-10.18	2ADFHV	11,0	Y1012J	92083	65

CAMRY

Camry		2.0	62	4	.90- .91	2C-T	11,0	Y-703R	3782	
Camry		2.0		4	- .92	1-CT	7,0	Y-146R	7492	

CARINA E

Carina E		2.0		4	02.92-	2C	11,0	Y-703R	3782	
----------	--	-----	--	---	--------	----	------	--------	------	--

CARINA II

Carina II		2.0		4	.93-	2C	11,0	Y-703R	3782	
Carina II		2.0		4	- .92	2C	7,0	Y-146R	7492	

COASTER

Coaster		4.0		6	05.82-	2H	14,0	Y-197R	2188	
---------	--	-----	--	---	--------	----	------	--------	------	--





l kW C
y
i



Stock-No
D-POWER

TOYOTA

COROLLA

Corolla Luna D-4D		1.4	66	4	.04- .07	1ND-TV		11,0	Y-542J	5513	45
Corolla		1.8		4	12.92-	1C		11,0	Y-703R	3782	
Corolla		1.8		4	- .92	1C		7,0	Y-146R	7492	
Corolla 2.0 D-4D	E11, CDE110	2.0	66	4	09.00-01.02	1CD-FTV		11,0	Y-531J	5467	44
Corolla 2.0 D-4D	E12, CDE120	2.0	66	4	01.02-05.04	1CD-FTV		11,0	Y-531J	5467	44
Corolla 2.0 D-4D	E12, CDE120	2.0	81	4	11.01-04.03	1CD-FTV		11,0	Y-531J	5467	44
Corolla 2.0 D-4D	E12, CDE120	2.0	85	4	05.03-05.08	1CD-FTV		11,0	Y-531J	5467	44
Corolla 2.0 D-4D	ADE150	2.0	93	4	11.06-07.14	1AD-FTV		11,0	Y1012J	92083	65
Corolla 2.0 D-4D	ADE150	2.0	93	4	11.06-07.14	1ADF-TV		11,0	Y1012J	92083	65
Corolla 2.2 D-4D	AUR10	2.2	100	4	09.05-03.09	2AD-FTV		11,0	Y1012J	92083	65
Corolla 2.2 D-4D	AUR10	2.2	100	4	09.05-03.09	2ADF-TV		11,0	Y1012J	92083	65
Corolla 2.2 D-4D	AUR10	2.2	130	4	07.05-03.09	2AD-FHV		11,0	Y1012J	92083	65
Corolla 2.2 D-4D	AUR10	2.2	130	4	07.05-03.09	2ADFHV		11,0	Y1012J	92083	65

COROLLA VERSO

Corolla Verso D-4D	D-4DE12, CDE120	2.0	66	4	01.02-05.04	1CD-FTV		11,0	Y-531J	5467	44
Corolla Verso D-4D	D-4DCE120, CDE120	2.0	85	4	10.01- .07	1CD-FTV		11,0	Y-531J	5467	44
Corolla Verso D-4D	D-4DZER, CUR10	2.0	85	4	04.04-08.05	1CD-FTV		11,0	Y-531J	5467	44

CORONA

Corona Super Glow System		2.2		4	08.82-	L		7,0	Y-118R	2187	
--------------------------	--	-----	--	---	--------	---	--	-----	--------	------	--

CRESSIDA

Cressida Super Glow System		2.2		4	08.82-	L		7,0	Y-118R	2187	
----------------------------	--	-----	--	---	--------	---	--	-----	--------	------	--

CROWN

Crown Super Glow System		2.2		4	08.80-	L		7,0	Y-118R	2187	
Crown		2.2		4	08.80-	L		11,0	Y-118T1	2951	
Crown		2.5		4	.93-	2L		11,0	Y-715R	5376	

DYNA

Dyna	KDY220, KDY230, KDY250, KDY260	2.5	65	4	08.01-08.06	2KD-FTV		11,0	Y-531J	5467	44
Dyna	KDY220, KDY230, KDY250, KDY260	2.5	75	4	08.01-	2KD-FTV		11,0	Y-531J	5467	44

DYNA 100

Dyna 100 2.4	LY100	2.4	58	4	05.95-07.01	2L		11,0	Y-715R	5376	
--------------	-------	-----	----	---	-------------	----	--	------	--------	------	--

DYNA 2500

Dyna 2500					.93-	2L		11,0	Y-715R	5376	
-----------	--	--	--	--	------	----	--	------	--------	------	--

DYNA 3000

Dyna 3000		3.0		4	.90- .91	B		20,5	Y-178T	3030	
Dyna 3000		3.0		4	.93-	B, 11B		10,5	Y-147T	7493	
Dyna 3000		3.0		4	.93-	B, 11B		23,0	Y-197T	2190	

DYNA 3700

Dyna 3700					.93-	14B		10,5	Y-147T	7493	
Dyna 3700					.93-	14B		23,0	Y-197T	2190	

ECHO NLP10

Echo NLP10		1.4	55	4	.02-	1ND-TV		11,0	Y-542J	5513	45
------------	--	-----	----	---	------	--------	--	------	--------	------	----





e kW C
y
i



Stock-No
D-POWER

TOYOTA

ECHO VERSO NLP20/22

Echo Verso NLP20/22	1.4		4	.02-	1ND-TV		11,0	Y-542J	5513	45
---------------------	-----	--	---	------	--------	--	------	--------	------	----

HIACE

Hiace 2.4	LXH12, LXH22	2.4	55	4	09.97-08.01	2L		11,0	Y-715R	5376	
Hiace 2.4	LXH12, LXH22	2.4	58	4	09.97-08.01	2L		11,0	Y-715R	5376	
Hiace 2.4 TD	LXH12, LXH22, LXH18, LXH28	2.4	66	4	08.95-04.98	2LT		11,0	Y-715R	5376	
Hiace 2500	LH102- LH104, LH112- LH115, LH125	2.4		4	.93-	2L		11,0	Y-715R	5376	
Hiace	KLH12, KLH18, KLH22, KLH28	2.5	65	4	08.01-08.06	2KD-FTV		11,0	Y-531J	5467	44
Hiace 2.5 D-4D		2.5	70	4	09.06-	2KD-FTV		11,0	Y-531J	5467	44
Hiace	KLH12, KLH18, KLH22, KLH28	2.5	75	4	08.01-08.06	2KD-FTV		11,0	Y-531J	5467	44
Hiace 2.5 D-4D	KLH12, KLH22	2.5	86	4	09.06-	2KD-FTV		11,0	Y-531J	5467	44
Hiace	LH102- LH104, LH112- LH115, LH125	2.5		4	.98-	2L		11,0	Y-715R	5376	
Hiace 2800		2.8		4	.93-	3L		11,0	Y-715R	5376	
Hiace	LH102- LH104, LH112- LH115, LH125	2.8		4	.98-	3L		11,0	Y-715R	5376	
Hiace 3000		3.0		4	.93-	B, 11B 12V		10,5	Y-147T	7493	
Hiace 3000		3.0		4	.93-	B, 11B 24V		23,0	Y-197T	2190	

HILUX

Hilux 2.4	LN145, LN150	2.4	58	4	08.97-07.05	2L		11,0	Y-715R	5376	
Hilux 2.4	LN145, LN150	2.4	61	4	08.97-08.01	2L		11,0	Y-715R	5376	
Hilux 2.4 TD	LN165, LN170	2.4	66	4	08.98-07.01	2LT		11,0	Y-715R	5376	
Hilux 2500		2.4		4	.93-	2L		11,0	Y-715R	5376	
Hilux		2.4		4	- .92	2L 12V		7,0	Y-118R	2187	
Hilux 2.5 D-4D	KDN145, KDN150, KDN165, KDN170, KDN190	2.5	65	4	08.01-08.05	2KD-FTV		11,0	Y-531J	5467	44
Hilux 2.5 D-4D	KUN15	2.5	75	4	06.06-	2KD-FTV		11,0	Y-531J	5467	44
Hilux 2.5 D-4D	KUN15	2.5	88	4	06.06-	2KD-FTV		11,0	Y-531J	5467	44
Hilux 2.5 D-4D	KUN25	2.5	106	4	12.07-	2KD-FTV		11,0	Y-531J	5467	44
Hilux 2800		2.8		4	.93-	3L		11,0	Y-715R	5376	
Hilux 3.0 D-4D	KUN26	3.0	126	4	08.05-	1KD-FTV		11,0	Y-531J	5467	44

IQ

iQ 1.4 D-4D	NUJ10	1.4	66	4	11.08-	1ND-TV		11,0	Y-542J	5513	45
-------------	-------	-----	----	---	--------	--------	--	------	--------	------	----





l kW C
Y
I



Stock-No
D-POWER

TOYOTA

LAND CRUISER

Land Cruiser		2.5		4	.90-	2L	11,0	Y-715R	5376	
Land Cruiser		2.5		4	.93-	2LT	11,0	Y-715R	5376	
Land Cruiser		2.8		4	.93-	3L	11,0	Y-715R	5376	
Land Cruiser	KZJ90, KZJ95	2.8		4	.98-	3L	11,0	Y-715R	5376	
Land Cruiser	LJ90, LJ95	2.8		4	.98-	3L	11,0	Y-715R	5376	
Land Cruiser	KZJ90, KZJ95	3.0	92	4	.98-	1KZT	11,0	Y1013J	94470	63
Land Cruiser	KZJ90, KZJ95	3.0	92	4	.98-	1KZTE	11,0	Y1013J	94470	63
Land Cruiser	LJ90, LJ95	3.0	92	4	.98-	1KZT	11,0	Y1013J	94470	63
Land Cruiser	LJ90, LJ95	3.0	92	4	.98-	1KZTE	11,0	Y1013J	94470	63
Land Cruiser D-4D	KDJ90, KDJ95, J9	3.0	120	4	10.00-08.02	1KD-FTV	11,0	Y-531J	5467	44
Land Cruiser 3.0 D-4D	KDJ120, KDJ125, J12	3.0	120	4	09.02-10.06	1KD-FTV	11,0	Y-531J	5467	44
Land Cruiser 3.0 D-4D	KDJ125, J12	3.0	122	4	08.04-10.06	1KD-FTV	11,0	Y-531J	5467	44
Land Cruiser 3.0 D-4D	KDJ120, KDJ125, J12	3.0	127	4	01.07-	1KD-FTV	11,0	Y-531J	5467	44
Land Cruiser 3.0 D-4D	KDJ150, J15	3.0	127	4	01.10-	1KD-FTV	11,0	Y-531J	5467	44
Land Cruiser 3.0 D-4D	KDJ150, KDJ155, J15	3.0	140	4	01.10-	1KD-FTV	11,0	Y-531J	5467	44
Land Cruiser	KZJ120	3.0		4	09.02-	1KD-FTV	11,0	Y-531J	5467	44
Land Cruiser	LJ120, LJ125	3.0		4	09.02-	1KD-FTV	11,0	Y-531J	5467	44
Land Cruiser	HDJ100	4.2		6	.98-	1HD-T	11,0	Y-532J	7782	
Land Cruiser	HZJ105	4.2		6	.98-	1HD-FTE	11,0	Y-532J	7782	
Land Cruiser	HZJ105	4.2		6	.98-	1HD-T	11,0	Y-532J	7782	
Land Cruiser 4.5 D-4D	VDJ200	4.5	171	8	01.13-	1VD-FTV	11,0	Y1012J	92083	65
Land Cruiser 4.5 D-4D	VDJ200	4.5	171	8	01.13-	1VDFTV	11,0	Y1012J	92083	65
Land Cruiser 4.5 D-4D	VDJ200	4.5	173	8	06.07-	1VD-FTV	11,0	Y1012J	92083	65
Land Cruiser 4.5 D-4D	VDJ200	4.5	173	8	06.07-	1VDFTV	11,0	Y1012J	92083	65
Land Cruiser 4.5 D-4D	VDJ200	4.5	183	8	08.15-	1VD-FTV	11,0	Y1012J	92083	65
Land Cruiser 4.5 D-4D	VDJ200	4.5	183	8	08.15-	1VDFTV	11,0	Y1012J	92083	65
Land Cruiser 4.5 D-4D	VDJ200	4.5	195	8	09.07-	1VD-FTV	11,0	Y1012J	92083	65
Land Cruiser 4.5 D-4D	VDJ200	4.5	195	8	09.07-	1VDFTV	11,0	Y1012J	92083	65
Land Cruiser 4.5 D-4D	VDJ200	4.5	200	8	01.12-	1VD-FTV	11,0	Y1012J	92083	65
Land Cruiser 4.5 D-4D	VDJ200	4.5	200	8	01.12-	1VDFTV	11,0	Y1012J	92083	65
Land Cruiser 4.5 D-4D	VDJ200	4.5	210	8	08.07-	1VD-FTV	11,0	Y1012J	92083	65
Land Cruiser 4.5 D-4D	VDJ200	4.5	210	8	08.07-	1VDFTV	11,0	Y1012J	92083	65
Land Cruiser					10.81-	2B	14,0	Y-197R	2188	
Land Cruiser				6	05.82-	H, 2H	14,0	Y-197R	2188	

PICNIC

Picnic TD	CXM10	2.2	66	4	.98-	3C-TE	11,0	Y1013J	94470	63
-----------	-------	-----	----	---	------	-------	------	--------	-------	----

PREVIA

Previa 2.0 D-4D	ACR3, CLR30	2.0	85	4	03.01-12.05	1CD-FTV	11,0	Y-531J	5467	44
-----------------	-------------	-----	----	---	-------------	---------	------	--------	------	----

RAV 4

RAV 4 2.0 D		2.0	85	4	06.01-10.05	1CD-FTV	11,0	Y-531J	5467	44
RAV 4 2.2 D-4D	ALA30	2.2	98	4	11.05-12.10	2AD-FTV	11,0	Y1012J	92083	65
RAV 4 2.2 D-4D	ALA30	2.2	100	4	02.06-12.12	2AD-FTV	11,0	Y1012J	92083	65



e kW C
y iStock-No
D-POWER™**TOYOTA****RAV 4**

RAV 4 2.2 D-4D	ALA30, ALA35, ALA49	2.2	110	4	12.08-06.13	2AD-FTV	11,0	Y1012J	92083	65
RAV 4 2.2 D-4D	ALA30, ALA49	2.2	130	4	02.06-06.13	2AD-FHV	11,0	Y1012J	92083	65

STARLET

Starlet		1.5		4	.90- .92	1N	11,0	Y-715R	5376	
Starlet		1.5		4	.93-	1N	11,0	Y-715R	5376	

TOWNACE

Townace	CR41	2.0		4	10.96-	2C	11,0	Y-532J	7782	
---------	------	-----	--	---	--------	----	------	--------	------	--

TOYO-ACE

Toyo-Ace Super Glow System		2.2		4	03.79-	L	7,0	Y-118R	2187	
Toyo-Ace		2.2		4	03.79-	L	11,0	Y-118T1	2951	
Toyo-Ace 3.0	LY225, LY235	3.0	65	4	08.01-06.11	5L	11,0	Y-715R	5376	
Toyo-Ace		3.0		4	01.82-	B	14,0	Y-197R	2188	

URBAN CRUISER

Urban Cruiser 1.4 D-4D	NSP110	1.4	66	4	01.09-	1ND-TV	11,0	Y-542J	5513	45
------------------------	--------	-----	----	---	--------	--------	------	--------	------	----

VERSO

Verso 2.0 D-4D	AUR20	2.0	93	4	04.09-08.18	1AD-FTV	11,0	Y1012J	92083	65
Verso 2.0 D-4D	AUR20	2.0	93	4	04.09-08.18	1ADFTV	11,0	Y1012J	92083	65
Verso 2.2 D-4D	AUR21	2.2	100	4	04.09-08.18	2AD-FHV	11,0	Y1012J	92083	65
Verso 2.2 D-4D	AUR21	2.2	100	4	04.09-08.18	2ADFHV	11,0	Y1012J	92083	65
Verso 2.2 D-4D	AUR21	2.2	110	4	04.09-08.18	2AD-FHV	11,0	Y1012J	92083	65
Verso 2.2 D-4D	AUR21	2.2	110	4	04.09-08.18	2ADFHV	11,0	Y1012J	92083	65
Verso 2.2 D-4D	AUR21	2.2	130	4	04.09-08.18	2AD-FHV	11,0	Y1012J	92083	65
Verso 2.2 D-4D	AUR21	2.2	130	4	04.09-08.18	2ADFHV	11,0	Y1012J	92083	65

YARIS

Yaris 1.4 D-4D	NLP10	1.4	55	4	12.01-	1ND-TV	11,0	Y-542J	5513	45
Yaris 1.4	NLP90	1.4	55	4	11.05-	1ND-TV	11,0	Y-542J	5513	45
Yaris 1.4 D-4D		1.4	66	4	02.06-	1ND-TV	11,0	Y-542J	5513	45

UAZ**425**

425 PP Promiscuo D				4	08.81-	Peugeot	11,0	Y-924J	7906	1
--------------------	--	--	--	---	--------	---------	------	--------	------	---

VOLKSWAGEN**AMAROK**

Amarok 2.0 TDI /BlueMotion	2HA, 2HB	2.0	90	4	09.10-10.13	CDBA	4,4	Y1002AS	8888	57
Amarok 2.0 TDI /BlueMotion	2HA, 2HB	2.0	90	4	09.10-10.13	CNFA	4,4	Y1002AS	8888	57
Amarok 2.0 TDI /BlueMotion	2HA, 2HB	2.0	103	4	05.12-	CNFB	4,4	Y1002AS	8888	57
Amarok 2.0 BiTDI	2HA, 2HB	2.0	120	4	11.09-08.12	CDCA	4,4	Y1002AS	8888	57
Amarok 2.0 BiTDI 4motion	2HA, 2HB	2.0	132	4	11.11-	CNEA	4,4	Y1002AS	8888	57
Amarok 2.0 BiTDI 4motion	2HA, 2HB	2.0	132	4	11.11-	CSHA	4,4	Y1002AS	8888	57

BEETLE

Beetle 2 TDi BlueMotion (only for cyl. without pressure sensor)	5C1	2.0	110	4	07.14-	DELA	4,4	Y1002AS	8888	57
---	-----	-----	-----	---	--------	------	-----	---------	------	----

BEETLE (9C1/1C1)

Beetle 1.9 TDI	9C1, 1C1	1.9	66	4	01.98-06.04	ALH	12,0	Y-732J	5605	4
Beetle 1.9 TDI (VIN->1J-2-600000)	9C1, 1C1	1.9	74	4	10.00-10.01	ATD	12,0	Y-732J	5605	4





el kW C
Y
I



Stock-No
D-POWER

VOLKSWAGEN

BEETLE (9C1/1C1)

Beetle 1.9 TDI (VIN 6L-2-001 501-→)	9C1, 1C1	1.9	74	4	10.00-	ATD	11,0	Y-741U	6943	20
Beetle 1.9 TDI	9C1, 1C1	1.9	74	4	06.03-	AXR	11,0	Y-741U	6943	20
Beetle 1.9 TDI	9C1, 1C1	1.9	74	4	07.05-12.06	BEW	7,0	CZ104	9826	52
Beetle 1.9 TDI	9C1, 1C1	1.9	77	4	07.05-	BSW	11,0	Y-741U	6943	20

BEETLE 2 (5C1)

Beetle 2 1.6 TDI / Blue Motion	5C1, 5C7	1.6	77	4	10.11-	CAYC	4,4	Y1002AS	8888	57
Beetle 2 2.0 TDI (only for cyl. without pressure sensor)	5C1, 5C7	2.0	81	4	12.14-	CUUA	4,4	Y1002AS	8888	57
Beetle 2 2.0 TDI (only for cyl. without pressure sensor)	5C1, 5C7	2.0	103	4	04.11-	CFFB	4,4	Y1002AS	8888	57
Beetle 2 2.0 TDI (only for cyl. without pressure sensor)	5C1, 5C7	2.0	103	4	04.11-	CJAA	4,4	Y1002AS	8888	57
Beetle 2 2.0 TDI (only for cyl. without pressure sensor)	5C1, 5C7	2.0	110	4	07.14-	CUUB	4,4	Y1002AS	8888	57
Beetle 2 2.0 TDI (only for cyl. without pressure sensor)	5C1, 5C7	2.0	110	4	07.14-	CVCA	4,4	Y1002AS	8888	57

BORA (1J1/1J6)

Bora 1.9 SDI	1J2, 1J6	1.9	50	4	11.98-05.05	AGP	12,0	Y-732J	5605	4
Bora 1.9 SDI	1J2, 1J6	1.9	50	4	11.98-05.05	AQM	12,0	Y-732J	5605	4
Bora 1.9 TDI	1J2, 1J6	1.9	66	4	09.98-05.03	ALH	12,0	Y-732J	5605	4
Bora 1.9 TDI	1J2, 1J6	1.9	66	4	10.98-05.05	AGR	12,0	Y-732J	5605	4
Bora 1.9 TDI (VIN→1J-2-600000)	1J2, 1J6	1.9	74	4	01.00-05.05	ATD	12,0	Y-732J	5605	4
Bora 1.9 TDI (VIN 1J-2-600001-→)	1J2, 1J6	1.9	74	4	05.00-05.05	ATD	11,0	Y-741U	6943	20
Bora 1.9 TDI (VIN→1J-2-600000)	1J2, 1J6	1.9	74	4	05.01-05.05	AXR	12,0	Y-732J	5605	4
Bora 1.9 TDI (VIN 1J-2-600001-→)	1J2, 1J6	1.9	74	4	05.01-05.05	AXR	11,0	Y-741U	6943	20
Bora 1.9 TDI	1J2, 1J6	1.9	81	4	09.98-05.05	AHF	12,0	Y-732J	5605	4
Bora 1.9 TDI	1J2, 1J6	1.9	81	4	05.99-05.05	ASV	12,0	Y-732J	5605	4
Bora 1.9 TDI	1J2, 1J6	1.9	85	4	11.98-07.01	AJM	12,0	Y-732J	5605	4
Bora 1.9 TDI	1J2, 1J6	1.9	85	4	11.98-07.01	AUY	12,0	Y-732J	5605	4
Bora 1.9 TDI (VIN→1J-2-600000)	1J2, 1J6	1.9	96	4	04.01-05.05	ASZ	12,0	Y-732J	5605	4
Bora 1.9 TDI (VIN 1J-2-600001-→)	1J2, 1J6	1.9	96	4	04.01-05.05	ASZ	11,0	Y-741U	6943	20
Bora 1.9 TDI (VIN→1J-2-600000)	1J2, 1J6	1.9	110	4	09.00-05.05	ARL	12,0	Y-732J	5605	4
Bora 1.9 TDI (VIN 1J-2-600001-→)	1J2, 1J6	1.9	110	4	09.00-05.05	ARL	11,0	Y-741U	6943	20

CADDY

Caddy		1.7	42	4	07.96-09.00	AHB	12,0	Y-918J	6285	2
Caddy 2 1.9 TDI	9K9	1.9	66	4	10.96-06.03	1Z	12,0	Y-732J	5605	4
Caddy 4 2.0 TDI BlueMotion (only for cyl. without pressure sensor)	SAA	2.0	55	4	05.15-	CUUC	4,4	Y1002AS	8888	57
Caddy 4 2.0 TDI BlueMotion (only for cyl. without pressure sensor)	SAA	2.0	55	4	05.15-	CUUF	4,4	Y1002AS	8888	57
Caddy 3 2.0 TDI	2CA	2.0	62	4	11.10-05.15	CFHE	4,4	Y1002AS	8888	57
Caddy 4 2.0 TDI BlueMotion (only for cyl. without pressure sensor)	SAA	2.0	75	4	05.15-	CUUD	4,4	Y1002AS	8888	57
Caddy 3 2.0 TDI	2CA	2.0	81	4	08.10-05.15	CLCA	4,4	Y1002AS	8888	57
Caddy 4 2.0 TDI BlueMotion (only for cyl. without pressure sensor)	SAA	2.0	90	4	05.15-	CUUE	4,4	Y1002AS	8888	57
Caddy 3 2.0 TDI	2CA	2.0	103	4	11.10-05.15	CLCB	4,4	Y1002AS	8888	57
Caddy 4 2.0 TDI BlueMotion (only for cyl. without pressure sensor)	SAA	2.0	110	4	05.15-	CUUB	4,4	Y1002AS	8888	57

CADDY I (14)

Caddy I 1.6 D	14	1.6	40	4	08.90-07.92	ME	12,0	Y-918J	6285	2
---------------	----	-----	----	---	-------------	----	------	--------	------	---





e kW C
y
i



Stock-No
D-POWER

VOLKSWAGEN

CADDY II (9K9A/9K9B)

Caddy II 1.7 SDi (color code: Black)	9K9A, 9K9B	1.7	42	4	10.96-09.00	AHB	12,0	Y-918J	6285	2
Caddy II 1.9 SDi	9K9A, 9K9B	1.9	47	4	11.95-01.04	AEY	12,0	Y-732J	5605	4
Caddy II 1.9 SDi	9K9A, 9K9B	1.9	47	4	11.95-01.04	AYQ	12,0	Y-732J	5605	4
Caddy II 1.9 D	9K9A, 9K9B	1.9	47	4	11.95-06.03	1Y	12,0	Y-918J	6285	2
Caddy II 1.9 -/SDi (color code: Black)	9K9A, 9K9B	1.9	47	4	11.95-01.04	AEY	12,0	Y-918J	6285	2
Caddy II 1.9 -/SDi (color code: Black)	9K9A, 9K9B	1.9	47	4	11.95-01.04	AYQ	12,0	Y-918J	6285	2
Caddy II 1.9 D	9K9A, 9K9B	1.9	47	4	06.96-12.00	AEF	12,0	Y-918J	6285	2
Caddy II 1.9 TDI	9K9A, 9K9B	1.9	66	4	10.96-06.03	AHU	12,0	Y-732J	5605	4
Caddy II 1.9 TDI	9K9A, 9K9B	1.9	66	4	10.96-06.03	ALE	12,0	Y-732J	5605	4
Caddy II 1.9 TDI	9K9A, 9K9B	1.9	66	4	10.96-06.03	ALH	12,0	Y-732J	5605	4
Caddy II 1.9 TDi	9K9A, 9K9B	1.9	66	4	10.96-06.03	1Z	12,0	Y-918J	6285	2
Caddy II 1.9 TDi	9K9A, 9K9B	1.9	66	4	10.96-06.03	AHU	12,0	Y-918J	6285	2
Caddy II 1.9 TDi	9K9A, 9K9B	1.9	66	4	10.96-06.03	ALE	12,0	Y-918J	6285	2
Caddy II 1.9 TDi	9K9A, 9K9B	1.9	66	4	10.96-06.03	ALH	12,0	Y-918J	6285	2

CADDY III (2KB/2KJ/2KA/2KH)

Caddy III 1.6 TDI	2KB, 2KJ, 2KA, 2KH	1.6	55	4	08.10-	CAYE	4,4	Y1002AS	8888	57
Caddy III 1.6 TDI	2KB, 2KJ, 2KA, 2KH	1.6	75	4	08.10-	CAYD	4,4	Y1002AS	8888	57
Caddy III 1.9 TDI	2KB, 2KJ, 2KA, 2KH	1.9	55	4	09.05-08.10	BSU	5,0	Y-607AS	7560	50
Caddy III 1.9 TDI	2KB, 2KJ, 2KA, 2KH	1.9	77	4	04.04-08.10	BJB	5,0	Y-607AS	7560	50
Caddy III 1.9 TDI	2KB, 2KJ, 2KA, 2KH	1.9	77	4	06.05-08.10	BLS	5,0	Y-607AS	7560	50
Caddy III 2.0 SDI	2KB, 2KJ, 2KA, 2KH	2.0	52	4	02.04-08.10	BDJ	11,0	Y-741U	6943	20
Caddy III 2.0 SDI	2KB, 2KJ, 2KA, 2KH	2.0	52	4	02.04-08.10	BST	11,0	Y-741U	6943	20
Caddy III 2.0 TDI 4motion	2KB, 2KJ, 2KA, 2KH	2.0	81	4	08.10-05.15	CFHF	4,4	Y1002AS	8888	57
Caddy III 2.0 TDI	2KB, 2KJ, 2KA, 2KH	2.0	103	4	09.07-08.10	BMM	5,0	Y-607AS	7560	50
Caddy III 2.0 TDI	2KB, 2KJ, 2KA, 2KH	2.0	103	4	05.15-	CFHC	4,4	Y1002AS	8888	57
Caddy III 2.0 TDI	2KB, 2KJ, 2KA, 2KH	2.0	125	4	05.12-05.15	CFJA	4,4	Y1002AS	8888	57

CC

CC 2.0 TDI	358	2.0	100	4	11.11-	CFFA	4,4	Y1002AS	8888	57
CC 2.0 TDI	358	2.0	103	4	11.11-	CFFB	4,4	Y1002AS	8888	57
CC TDI BlueMotion (only for cyl. without pressure sensor)	358	2.0	110	4	05.15-	CUVC	4,4	Y1002AS	8888	57
CC 2.0 TDI	358	2.0	125	4	11.11-	CFGB	4,4	Y1002AS	8888	57
CC 2.0 TDI	358	2.0	125	4	11.11-	CLLA	4,4	Y1002AS	8888	57
CC 2.0 TDI	358	2.0	130	4	12.12-	CFGC	4,4	Y1002AS	8888	57
CC TDI BlueMotion (only for cyl. without pressure sensor)	358	2.0	135	4	05.15-	CUWA	4,4	Y1002AS	8888	57

CRAFTER

Crafter 2.0 TDI	2E, 2F	2.0	80	4	05.11-	CKTB	4,4	Y1002AS	8888	57
Crafter 2.0 TDI	2E, 2F	2.0	100	4	05.11-	CKTC	4,4	Y1002AS	8888	57
Crafter 2.0 TDI	2E, 2F	2.0	105	4	10.11-	CKUC	4,4	Y1002AS	8888	57
Crafter 2.0 TDI	2E, 2F	2.0	120	4	07.11-	CKUB	4,4	Y1002AS	8888	57
Crafter 2.5 TDI only for engine with ceramic glow plug	2E, 2F	2.5	65	5	04.06-07.11	BJJ	7,0	CZ104	9826	52
Crafter 2.5 TDI	2E, 2F	2.5	65	5	04.06-07.11	BJJ	5,0	Y-607AS	7560	50





l kW
C
Y
I



Stock-No
D-POWER

VOLKSWAGEN

CRAFTER

Crafter 2.5 TDI only for engine with ceramic glow plug	2E, 2F	2.5	65	5	05.09-07.11	CEBA	7,0	CZ104	9826	52
Crafter 2.5 TDI	2E, 2F	2.5	65	5	05.09-07.11	CEBA	5,0	Y-607AS	7560	50
Crafter 2.5 TDI only for engine with ceramic glow plug	2E, 2F	2.5	80	5	04.06-07.11	BJK	7,0	CZ104	9826	52
Crafter 2.5 TDI	2E, 2F	2.5	80	5	04.06-05.13	BJK	5,0	Y-607AS	7560	50
Crafter 2.5 TDI only for engine with ceramic glow plug	2E, 2F	2.5	80	5	05.09-07.11	CEBB	7,0	CZ104	9826	52
Crafter 2.5 TDI	2E, 2F	2.5	80	5	05.09-07.11	CEBB	5,0	Y-607AS	7560	50
Crafter 2.5 TDI only for engine with ceramic glow plug	2E, 2F	2.5	100	5	04.06-	BJL	7,0	CZ104	9826	52
Crafter 2.5 TDI	2E, 2F	2.5	100	5	04.06-05.13	BJL	5,0	Y-607AS	7560	50
Crafter 2.5 TDI only for engine with ceramic glow plug	2E, 2F	2.5	100	5	05.09-	CECA	7,0	CZ104	9826	52
Crafter 2.5 TDI	2E, 2F	2.5	100	5	05.09-	CECA	5,0	Y-607AS	7560	50
Crafter 2.5 TDI only for engine with ceramic glow plug	2E, 2F	2.5	120	5	04.06-07.11	BJM	7,0	CZ104	9826	52
Crafter 2.5 TDI	2E, 2F	2.5	120	5	04.06-07.11	BJM	5,0	Y-607AS	7560	50
Crafter 2.5 TDI only for engine with ceramic glow plug	2E, 2F	2.5	120	5	05.09-07.11	CECB	7,0	CZ104	9826	52
Crafter 2.5 TDI	2E, 2F	2.5	120	5	05.09-07.11	CECB	5,0	Y-607AS	7560	50

CRAFTER 30

Crafter TDi/BlueMotion	2EB, 2EE	2.0	120	4	07.11-	CSNA	4,4	Y1002AS	8888	57
------------------------	----------	-----	-----	---	--------	------	-----	---------	------	----

CRAFTER 32

Crafter TDi/BlueMotion	2EH, 2EX	2.0	84	4	11.13-	CSLB	4,4	Y1002AS	8888	57
------------------------	----------	-----	----	---	--------	------	-----	---------	------	----

EOS

Eos 2.0 TDI	1F8	2.0	100	4	11.10-	CFFA	4,4	Y1002AS	8888	57
Eos 2.0 TDI	1F8	2.0	100	4	11.10-	CFHB	4,4	Y1002AS	8888	57
Eos 2.0 TDI	1F7	2.0	103	4	05.06-05.08	BMM	5,0	Y-607AS	7560	50
Eos 2.0 TDI	1F7	2.0	103	4	05.08-11.10	CBAB	4,4	Y-609AS	5849	49
Eos 2.0 TDI	1F8	2.0	103	4	11.10-	CFFB	4,4	Y1002AS	8888	57
Eos 2.0 TDI	1F8	2.0	103	4	11.10-	CFHC	4,4	Y1002AS	8888	57

FOX

Fox 1.4 TDI	5Z1	1.4	51	3	04.05-	BNM	11,0	Y-741U	6943	20
-------------	-----	-----	----	---	--------	-----	------	--------	------	----

GOLF I

Golf I D, TD		1.6	40	4	08.80-10.91		12,0	Y-918J	6285	2
--------------	--	-----	----	---	-------------	--	------	--------	------	---

GOLF II

Golf II 1.6 D	19E, 1G1	1.6	40	4	01.84-10.91	JP	12,0	Y-918J	6285	2
Golf II 1.6 TD	19E, 1G1	1.6	44	4	08.89-07.92	1V	12,0	Y-918J	6285	2
Golf II 1.6 TD	19E, 1G1	1.6	51	4	08.83-10.91	JR	12,0	Y-918J	6285	2
Golf II 1.6 TD	19E, 1G1	1.6	59	4	04.89-10.91	RA	12,0	Y-918J	6285	2
Golf II 1.6 TD	19E, 1G1	1.6	59	4	08.89-10.91	SB	12,0	Y-918J	6285	2

GOLF III

Golf III 1.9 SDI	1H1, 1H5	1.9	47	4	08.91-09.97	AEY	12,0	Y-732J	5605	4
Golf III 1.9 -/SDi (color code: Black)	1H1	1.9	47	4	11.91-12.97	AEY	12,0	Y-918J	6285	2
Golf III 1.9 D	1H1, 1H5	1.9	48	4	08.91-12.97	1Y	12,0	Y-918J	6285	2
Golf III 1.9 TD	1H1, 1H5	1.9	55	4	08.91-09.97	AAZ	12,0	Y-918J	6285	2
Golf III 1.9 TDI	1H1, 1H5	1.9	66	4	07.93-07.96	1Z	12,0	Y-732J	5605	4
Golf III 1.9 TDI	1H1, 1H5	1.9	66	4	05.96-12.01	ALE	12,0	Y-732J	5605	4
Golf III	1H1, 1H5	1.9	66	4	07.96-06.00	AHU	12,0	Y-732J	5605	4





e kW C
y
i



Stock-No
D-POWER™

VOLKSWAGEN

GOLF III

Golf III 1.9 TDI	1H1, 1H5	1.9	66	4	07.96-06.00	AHU	12,0	Y-732J	5605	4
Golf III 1.9 TDI	1H1, 1H5	1.9	81	4	02.96-08.99	AFN	12,0	Y-732J	5605	4

GOLF IV

Golf IV 1.9 SDI	1J1, 1J5	1.9	50	4	10.97-05.04	AGP	12,0	Y-732J	5605	4
Golf IV 1.9 SDI	1J1, 1J5	1.9	50	4	10.97-05.06	AQM	12,0	Y-732J	5605	4
Golf IV 1.9 TDI	1J1, 1J5	1.9	66	4	10.97-05.06	AGR	12,0	Y-732J	5605	4
Golf IV 1.9 TDI	1J1, 1J5	1.9	66	4	10.97-05.03	ALH	12,0	Y-732J	5605	4
Golf IV 1.9 TDI (VIN→1J-2-600000)	1J1, 1J5	1.9	74	4	02.00-06.06	ATD	12,0	Y-732J	5605	4
Golf IV 1.9 TDI (VIN 1J-2-600001→)	1J1, 1J5	1.9	74	4	02.00-06.06	ATD	11,0	Y-741U	6943	20
Golf IV 1.9 TDI (VIN→1J-2-600000)	1J1, 1J5	1.9	74	4	05.01-06.06	AXR	12,0	Y-732J	5605	4
Golf IV 1.9 TDI (VIN 1J-2-600001→)	1J1, 1J5	1.9	74	4	05.01-06.06	AXR	11,0	Y-741U	6943	20
Golf IV 1.9 TDI	1J1, 1J5	1.9	81	4	10.97-05.06	AHF	12,0	Y-732J	5605	4
Golf IV 1.9 TDI	1J1, 1J5	1.9	81	4	10.97-05.06	ASV	12,0	Y-732J	5605	4
Golf IV 1.9 TDI	1J1, 1J5	1.9	81	4	08.99-10.00	AVG	12,0	Y-732J	5605	4
Golf IV 1.9 TDI	1J1, 1J5	1.9	85	4	05.99-04.02	AJM	12,0	Y-732J	5605	4
Golf IV 1.9 TDI	1J1, 1J5	1.9	85	4	05.99-07.01	AUY	12,0	Y-732J	5605	4
Golf IV 1.9 TDI (VIN→1J-2-600000)	1J1, 1J5	1.9	96	4	04.01-05.06	ASZ	12,0	Y-732J	5605	4
Golf IV 1.9 TDI (VIN 1J-2-600001→)	1J1, 1J5	1.9	96	4	04.01-05.06	ASZ	11,0	Y-741U	6943	20
Golf IV 1.9 TDI (VIN→1J-2-600000)	1J1, 1J5	1.9	110	4	09.00-05.06	ARL	12,0	Y-732J	5605	4
Golf IV 1.9 TDI (VIN 1J-2-600001→)	1J1, 1J5	1.9	110	4	09.00-05.06	ARL	11,0	Y-741U	6943	20

GOLF V

Golf V 1.9 TDI	1K1, 1K5	1.9	66	4	05.04-11.08	BRU	5,0	Y-607AS	7560	50
Golf V 1.9 TDI	1K1, 1K5	1.9	66	4	02.06-01.09	BXF	5,0	Y-607AS	7560	50
Golf V 1.9 TDI	1K1, 1K5	1.9	66	4	05.07-01.09	BXJ	5,0	Y-607AS	7560	50
Golf V 1.9 TDI	1K1, 1K5	1.9	77	4	10.03-11.08	BXE	5,0	Y-607AS	7560	50
Golf V 1.9 TDI	1K1, 1K5	1.9	77	4	10.03-11.08	BKC	5,0	Y-607AS	7560	50
Golf V 1.9 TDI	1K1, 1K5	1.9	77	4	10.03-07.09	BLS	5,0	Y-607AS	7560	50
Golf V 2.0 SDI	1K1, 1K5	2.0	55	4	01.04-05.07	BDK	5,0	Y-607AS	7560	50
Golf V 2.0 TDI	1K1, 1K5	2.0	100	4	10.03-07.09	AZV	4,4	YE14	7768	48
Golf V 2.0 TDI	1K1, 1K5	2.0	100	4	10.08-11.09	CBAA	4,4	Y1002AS	8888	57
Golf V 2.0 TDI	1K1, 1K5	2.0	100	4	07.09-07.13	CBDA	4,4	Y1002AS	8888	57
Golf V 2.0 TDI	1K1, 1K5	2.0	103	4	10.03-07.09	BKD	4,4	YE14	7768	48
Golf V 2.0 TDI	1K1, 1K5	2.0	103	4	12.04-11.08	BMM	5,0	Y-607AS	7560	50
Golf V 2.0 TDI	1K1, 1K5	2.0	125	4	11.05-11.08	BMN	7,0	CZ304	9864	55

GOLF VI

Golf VI 1.6 TDI	5K1, AJ5	1.6	66	4	02.09-11.12	CAYB	4,4	Y1002AS	8888	57
Golf VI 1.6 TDI	5K1, AJ5	1.6	77	4	01.09-11.12	CAYC	4,4	Y1002AS	8888	57
Golf VI 2.0 TDI	5K1, AJ5	2.0	81	4	10.08-11.12	CBDC	4,4	Y1002AS	8888	57
Golf VI 2.0 TDI	5K1, AJ5	2.0	81	4	01.09-08.14	CLCA	4,4	Y1002AS	8888	57
Golf VI 2.0 TDI	5K1, AJ5	2.0	100	4	10.08-11.12	CBAA	4,4	Y1002AS	8888	57
Golf VI 2.0 TDI	5K1, AJ5	2.0	100	4	10.08-11.12	CFFA	4,4	Y1002AS	8888	57
Golf VI 2.0 TDI	5K1, AJ5	2.0	100	4	07.09-07.13	CFHB	4,4	Y1002AS	8888	57
Golf VI 2.0 TDI	1K5	2.0	103	4	05.07-07.09	CBDB	4,4	Y1002AS	8888	57
Golf VI 2.0 TDI	5K1, AJ5	2.0	103	4	10.08-11.12	CFFB	4,4	Y1002AS	8888	57
Golf VI 2.0 TDI/ BlueMotion	5K1, AJ5	2.0	103	4	10.08-11.12	CBAB	4,4	Y1002AS	8888	57



e kW C
Y IStock-No
D-POWER**VOLKSWAGEN****GOLF VI**

Golf VI 2.0 TDI	AJ5	2.0	103	4	07.09-07.13	CFHC	4,4	Y1002AS	8888	57
Golf VI 2.0 TDI GTD	5K1	2.0	125	4	04.09-11.12	CBBB	4,4	Y1002AS	8888	57
Golf VI 2.0 TDI GTD	5K1	2.0	125	4	04.09-11.12	CFGB	4,4	Y1002AS	8888	57

GOLF VII

Golf VII 1.6 TDI (only for cyl. without pressure sensor)	5G1, BA5	1.6	66	4	04.13-	CLHB	4,4	Y1002AS	8888	57
Golf VII 1.6 TDI (only for cyl. without pressure sensor)	5G1, BA5	1.6	66	4	04.13-	CRKA	4,4	Y1002AS	8888	57
Golf VII 1.6 TDI (only for cyl. without pressure sensor)	5G1, BA5	1.6	66	4	04.13-	CXXA	4,4	Y1002AS	8888	57
Golf VII 1.6 TDI (only for cyl. without pressure sensor)	5G1, BA5	1.6	77	4	08.12-	CLHA	4,4	Y1002AS	8888	57
Golf VII 1.6 TDI (only for cyl. without pressure sensor)	5G1, BA5	1.6	81	4	01.13-	CRKB	4,4	Y1002AS	8888	57
Golf VII AllTrack 1.6 TDI (only for cyl. without pressure sensor)	5G1, BA5	1.6	81	4	01.13-	CRKB	4,4	Y1002AS	8888	57
Golf VII 1.6 TDI BlueMotion (only for cyl. without pressure sensor)	5G1	1.6	81	4	01.13-	CVRA	4,4	Y1002AS	8888	57
Golf VII 1.6 TDI (only for cyl. without pressure sensor)	5G1, BA5	1.6	81	4	05.13-	CXXB	4,4	Y1002AS	8888	57
Golf VII 1.6 TDI (only for cyl. without pressure sensor)	BA5	1.6	81	4	05.13-	DBKA	4,4	Y1002AS	8888	57
Golf VII 2.0 TDI (only for cyl. without pressure sensor)	5G1, BA5	2.0	81	4	08.12-	CRVC	4,4	Y1002AS	8888	57
Golf VII 2.0 TDI (only for cyl. without pressure sensor)	5G1, BA5	2.0	81	4	11.12-	CRVA	4,4	Y1002AS	8888	57
Golf VII 2.0 TDI BlueMotion (only for cyl. without pressure sensor)	5G1	2.0	81	4	11.12-	CYKB	4,4	Y1002AS	8888	57
Golf VII 2.0 TDi/TDi BlueMotion (only for cyl. without pressure sensor)	517	2.0	81	4	11.13-	CUUA	4,4	Y1002AS	8888	57
Golf VII 2.0 TDI (only for cyl. without pressure sensor)	5G1, BA5	2.0	105	4	08.12-	CRBB	4,4	Y1002AS	8888	57
Golf VII 2.0 TDI (only for cyl. without pressure sensor)	5G1, BA5	2.0	110	4	08.12-	CRBC	4,4	Y1002AS	8888	57
Golf VII 2.0 TDI (only for cyl. without pressure sensor)	5G1, BA5	2.0	110	4	08.12-	CRLB	4,4	Y1002AS	8888	57
Golf VII 2.0 TDI BlueMotion (only for cyl. without pressure sensor)	5G1	2.0	110	4	08.12-	CKFC	4,4	Y1002AS	8888	57
Golf VII Alltrack 2.0 TDI 4Motion (only for cyl. without pressure sensor)	BA5	2.0	110	4	04.13-	CRBC	4,4	Y1002AS	8888	57
Golf VII Alltrack 2.0 TDI BlueMotion (only for cyl. without pressure sensor)	BA5	2.0	110	4	12.14-	CRLB	4,4	Y1002AS	8888	57
Golf VII 2.0 GTD (only for cyl. without pressure sensor)	5G1	2.0	135	4	04.13-	CUNA	4,4	Y1002AS	8888	57
Golf VII Alltrack 2.0 TDI 4Motion (only for cyl. without pressure sensor)	BA5	2.0	135	4	12.14-	CUNA	4,4	Y1002AS	8888	57

GOLF PLUS

Golf Plus 1.6 TDI	521	1.6	66	4	02.09-08.14	CAYB	4,4	Y1002AS	8888	57
Golf Plus 1.6 TDI	521	1.6	77	4	02.09- .13	CAYC	4,4	Y1002AS	8888	57
Golf Plus 1.9 TDI	5M1	1.9	66	4	05.05-12.08	BRU	5,0	Y-607AS	7560	50
Golf Plus 1.9 TDI	5M1	1.9	66	4	02.06-12.08	BXF	5,0	Y-607AS	7560	50
Golf Plus 1.9 TDI	5M1	1.9	66	4	05.07-12.08	BXJ	5,0	Y-607AS	7560	50
Golf Plus 1.9 TDI	5M1	1.9	77	4	01.05-01.09	BKC	5,0	Y-607AS	7560	50
Golf Plus 1.9 TDI	5M1	1.9	77	4	01.05-01.09	BXE	5,0	Y-607AS	7560	50
Golf Plus 1.9 TDI	5M1	1.9	77	4	01.05-01.09	BLS	5,0	Y-607AS	7560	50
Golf Plus 2.0 TDI	521	2.0	81	4	01.09-08.14	CLCA	4,4	Y1002AS	8888	57
Golf Plus 2.0 TDI	521	2.0	81	4	03.09-05.11	CBDC	4,4	Y1002AS	8888	57
Golf Plus 2.0 TDI	5M1	2.0	96	4	05.05-05.07	BEE	4,4	YE14	7768	48
Golf Plus 2.0 TDI	521	2.0	100	4	01.05-08.14	CBDA	4,4	Y1002AS	8888	57
Golf Plus 2.0 TDI	5M1	2.0	100	4	05.05-05.07	AZV	4,4	YE14	7768	48





e kW y i



Stock-No
D-POWER™

VOLKSWAGEN

GOLF PLUS

Golf Plus 2.0 TDI	5M1	2.0	100	4	01.09-	CFHB	4,4	Y1002AS	8888	57
Golf Plus 2.0 TDI	5M1	2.0	103	4	10.03-01.05	BKD	4,4	YE14	7768	48
Golf Plus 2.0 TDI	521	2.0	103	4	01.05-08.14	CBDB	4,4	Y1002AS	8888	57
Golf Plus 2.0 TDI	5M1	2.0	103	4	12.05-05.09	BMM	5,0	Y-607AS	7560	50
Golf Plus 2.0 TDI	521	2.0	103	4	10.08- .13	CFHC	4,4	Y1002AS	8888	57

GOLF SPORTSVAN

Golf Sportsvan 1.6 TDI (only for cyl. without pressure sensor)	AM1	1.6	66	4	02.14-	CRKA	4,4	Y1002AS	8888	57
Golf Sportsvan 1.6 TDI (only for cyl. without pressure sensor)	AM1	1.6	81	4	02.14-	CRKB	4,4	Y1002AS	8888	57
Golf Sportsvan 2.0 TDI (only for cyl. without pressure sensor)	AM1	2.0	81	4	05.14-	CRVA	4,4	Y1002AS	8888	57
Golf Sportsvan 2.0 TDI (only for cyl. without pressure sensor)	AM1	2.0	110	4	02.14-	CRLB	4,4	Y1002AS	8888	57

JETTA II

Jetta II 1.6 D	19E, 1G2	1.6	40	4	01.84-10.91	JP	12,0	Y-918J	6285	2
Jetta II 1.6 TD	19E, 1G2	1.6	44	4	01.90-10.91	1V	12,0	Y-918J	6285	2
Jetta II 1.6 TD	19E, 1G2	1.6	51	4	01.84-10.91	JR	12,0	Y-918J	6285	2
Jetta II 1.6 TD	19E, 1G2	1.6	59	4	04.89-10.91	RA	12,0	Y-918J	6285	2
Jetta II 1.6 TD	19E, 1G2	1.6	59	4	04.89-10.91	SB	12,0	Y-918J	6285	2

JETTA III

Jetta III 2.0 TDI	1K2	2.0	100	4	05.05-10.10	CBDB	4,4	Y1002AS	8888	57
Jetta III 2.0 TDI	1K2	2.0	100	4	09.05-10.10	CBDA	4,4	Y1002AS	8888	57
Jetta III 2.0 TDI	1K2	2.0	125	4	06.06-10.10	CEGA	4,4	Y1002AS	8888	57
Jetta III 1.9 TDI (For USA)	1K2	1.9	74	4	01.05-	BRM	7,0	CZ104	9826	52
Jetta III 1.9 TDI	1K2	1.9	77	4	08.05-10.10	BKC	7,0	CZ104	9826	52
Jetta III 1.9 TDI	1K2	1.9	77	4	08.05-10.10	BLS	7,0	CZ104	9826	52
Jetta III 1.9 TDI	1K2	1.9	77	4	09.05-10.10	BXE	7,0	CZ104	9826	52
Jetta III 2.0 TDI	1K2	2.0	100	4	09.05-10.10	AZV	4,4	YE14	7768	48
Jetta III 2.0 TDI	1K2	2.0	103	4	08.05-10.10	BKD	4,4	YE14	7768	48
Jetta III 2.0 TDI	1K2	2.0	103	4	10.05-06.08	BMM	5,0	Y-607AS	7560	50
Jetta III 2.0 TDI	1K2	2.0	125	4	06.06-06.08	BMN	7,0	CZ304	9864	55

JETTA IV

Jetta IV 1.6 TDI	1K2	1.6	77	4	07.09-10.10	CAYC	4,4	Y1002AS	8888	57
Jetta IV 2.0 TDi BlueMotion (only for cyl. without pressure sensor)	163	2.0	110	4	07.14-	DELA	4,4	Y1002AS	8888	57
Jetta IV 2.0 TSi	162, 163	2.0	155	4	12.12-10.10	CPLA	4,4	Y1002AS	8888	57
Jetta IV 1.6 TDI	162	1.6	77	4	02.11-	CAYC	4,4	Y1002AS	8888	57
Jetta IV 2.0 TDI	162	2.0	81	4	10.10-	CLCA	4,4	Y1002AS	8888	57
Jetta IV 2.0 TDI (only for cyl. without pressure sensor)	163	2.0	81	4	10.10-	CUUA	4,4	Y1002AS	8888	57
Jetta IV 2.0 TDI	162	2.0	103	4	10.10-	CFFB	4,4	Y1002AS	8888	57
Jetta IV 2.0 TDI	162	2.0	103	4	10.10-	CLCB	4,4	Y1002AS	8888	57
Jetta IV 2.0 TDI (only for cyl. without pressure sensor)	163	2.0	110	4	12.10-	CUUB	4,4	Y1002AS	8888	57
Jetta IV 2.0 TDI (only for cyl. without pressure sensor)	163	2.0	110	4	07.14-	CVCA	4,4	Y1002AS	8888	57

LT

LT		2.4	51	5	08.89-03.96		12,0	Y-918J	6285	2
LT		2.4	51	6	08.92-12.95	ACT	12,0	Y-918J	6285	2
LT		2.4	55	5	08.78-03.96		12,0	Y-918J	6285	2





l kW C
y
i



Stock-No
D-POWER

VOLKSWAGEN

LT

LT TD	2.4	55	5	08.78-03.96		12,0	Y-918J	6285	2
LT TD	2.4	55	6	12.82-07.92	DW	12,0	Y-918J	6285	2
LT TD 4X4	2.4	55	5	09.85-03.96		12,0	Y-918J	6285	2
LT TD	2.4	68	5	12.82-03.96		12,0	Y-918J	6285	2
LT Td	2.4	68	6	08.88-07.91	1G	12,0	Y-918J	6285	2
LT TD	2.4	70	6	08.91-12.95	ACL	12,0	Y-918J	6285	2
LT TD	2.4	75	6	12.82-07.92	DV	12,0	Y-918J	6285	2
LT TDI	2.5	61	5	04.01-07.06	BBE	12,0	Y-732J	5605	4
LT	2.5	65	5	04.06-	BJJ	7,0	CZ104	9826	52
LT TDI	2.5	66	5	05.99-05.03	APA	12,0	Y-732J	5605	4
LT TDI	2.5	70	5	04.01-07.06	BBF	12,0	Y-732J	5605	4
LT TDI	2.5	75	5	05.96-05.99	AHD	12,0	Y-732J	5605	4
LT TDI	2.5	80	5	05.96-07.06	ANJ	12,0	Y-732J	5605	4
LT TDI	2.5	80	5	05.96-06.06	AVR	12,0	Y-732J	5605	4
LT TDI	2.5	80	5	04.06-	BJK	7,0	CZ104	9826	52
LT TDI	2.5	100	5	04.06-	BJL	7,0	CZ104	9826	52
LT TDI	2.5	120	5	04.06-	BJM	7,0	CZ104	9826	52

LT 28

LT 28 D	2.4	51	6	08.88-12.95	1S	12,0	Y-918J	6285	2
LT 28 D	2.4	55	6	08.78-		12,0	Y-918J	6285	2
LT 28 D TD	2.4	68	6	12.82-		12,0	Y-918J	6285	2
LT 28 SDI	2.5	55	5	05.96-04.01	AGX	12,0	Y-732J	5605	4
LT 28 TDi	2.8	92	6	05.96-		12,0	Y-732J	5605	4

LT 31

LT 31 D	2.4	51	6	08.88-12.95	1S	12,0	Y-918J	6285	2
LT 31 D	2.4	55	6	08.78-		12,0	Y-918J	6285	2
LT 31 D TD	2.4	68	6	12.82-		12,0	Y-918J	6285	2

LT 35

LT 35 SDI	2.5	55	5	05.96-04.01	AGX	12,0	Y-732J	5605	4
LT 35 TDi	2.8	92	5	05.96-		12,0	Y-732J	5605	4

LT 40

LT 40 D	2.4	51	6	08.88-12.95	1S	12,0	Y-918J	6285	2
LT 40 D	2.4	55	6	08.78-		12,0	Y-918J	6285	2
LT 40 D / TD 4X4	2.4	55	4	09.85-		12,0	Y-918J	6285	2
LT 40 D TD	2.4	68	4	12.82-		12,0	Y-918J	6285	2

LT 45

LT 45 D / TD 4X4	2.4	55	4	08.78-		12,0	Y-918J	6285	2
LT 45 D / TD	2.4	55	4	09.85-		12,0	Y-918J	6285	2

LT 50

LT 50 D / TD	2.4	55	4	08.78-		12,0	Y-918J	6285	2
--------------	-----	----	---	--------	--	------	--------	------	---

LT 55

LT 55 D / TD	2.4	55	4	08.78-		12,0	Y-918J	6285	2
--------------	-----	----	---	--------	--	------	--------	------	---

LUPO

Lupo 1.2 TDI 3L	6X1, 6E1	1.2	45	3	06.99-07.05	ANY	12,0	Y-732J	5605	4
Lupo 1.2 TDI 3L (N10140105) (VIN No->6x-2-005 000)	6X1, 6E1	1.2	45	3	11.00-07.05	AYZ	12,0	Y-732J	5605	4



e kW C
y iStock-No
D-POWER™**VOLKSWAGEN****LUPU**

Lupo 1.2 TDI 3L (N10579202) (VIN No 6x-2-005 001→)	6X1, 6E1	1.2	45	3	11.00-07.05	AYZ	11,0	Y-741U	6943	20
Lupo 1.4 TDI (N10140102) (VIN->6x-2-005 000)	6X1, 6E1	1.4	55	3	05.99-07.05	AMF	12,0	Y-732J	5605	4
Lupo 1.4 TDI (N10579202) (VIN 6x-2-005 001→)	6X1, 6E1	1.4	55	3	05.99-07.05	AMF	11,0	Y-741U	6943	20
Lupo 1.7 SDI	6X1, 6E1	1.7	42	3	10.98-07.05	AKU	12,0	Y-732J	5605	4
Lupo 1.7 SDi (color code: Black)	6X1	1.7	44	4	10.98-07.05	AKU	12,0	Y-918J	6285	2

PASSAT III

Passat III 1.6 TD	35i, 3A2, 3A5	1.6	59	4	08.89-10.93	SB	12,0	Y-918J	6285	2
Passat III 1.9 D	35i, 3A2, 3A5	1.9	47	4	05.89-10.93	1Y	12,0	Y-918J	6285	2
Passat III 1.9 TD	35i, 3A2, 3A5	1.9	55	4	03.91-12.96	AAZ	12,0	Y-918J	6285	2
Passat III 1.9 TDI	35i, 3A2, 3A5	1.9	66	4	10.93-12.96	1Z	12,0	Y-732J	5605	4
Passat III 1.9 TDI	35i, 3A2, 3A5	1.9	66	4	10.93-08.00	AHU	12,0	Y-732J	5605	4
Passat III 1.9 TDI	35i, 3A2, 3A5	1.9	81	4	10.96-08.00	AFN	12,0	Y-732J	5605	4

PASSAT IV

Passat IV 1.9 TDI	3B2, 3B5	1.9	66	4	10.96-08.00	AHH	12,0	Y-732J	5605	4
Passat IV 1.9 TDI (VIN→3B-2-350-000)	3B2, 3B3, 3B5, 3B6	1.9	74	4	10.00-05.05	AVB	12,0	Y-732J	5605	4
Passat IV 1.9 TDI (VIN 3B-2-350-001→)	3B2, 3B3, 3B5, 3B6	1.9	74	4	10.00-05.05	AVB	11,0	Y-741U	6943	20
Passat IV 1.9 TDI	3B2, 3B5	1.9	81	4	08.99-08.00	AVG	12,0	Y-732J	5605	4
Passat IV 1.9 TDI	3B2, 3B5	1.9	85	4	01.99-08.00	AJM	12,0	Y-732J	5605	4
Passat IV 1.9 TDI	3B2, 3B5	1.9	85	4	01.00-08.00	ATJ	12,0	Y-732J	5605	4
Passat IV 1.9 TDI (VIN→3B-2-350-000)	3B3, 3B6	1.9	96	4	10.00-05.05	AVF	12,0	Y-732J	5605	4
Passat IV 1.9 TDI (VIN→3B-2-350-000)	3B3, 3B6	1.9	96	4	10.00-05.05	AWX	12,0	Y-732J	5605	4
Passat IV 1.9 TDI (VIN 3B-2-350-001→)	3B3, 3B6	1.9	96	4	10.00-05.05	AVF	11,0	Y-741U	6943	20
Passat IV 1.9 TDI (VIN 3B-2-350-001→)	3B3, 3B6	1.9	96	4	10.00-05.05	AWX	11,0	Y-741U	6943	20
Passat IV 2.5 TDI V6	3B2, 3B3, 3B5, 3B6	2.5	110	6	07.98-05.03	AKN	11,0	Y-501U	4187	31
Passat IV 2.5 TDI V6	3B2, 3B3, 3B5, 3B6	2.5	110	6	08.98-05.03	AFB	11,0	Y-501U	4187	31
Passat IV 2.5 TDI V6	3B3, 3B6	2.5	120	6	05.03-05.05	BDG	11,0	Y-501U	4187	31
Passat IV 2.5 TDI V6 4motion	3B3, 3B6	2.5	132	6	01.03-05.05	BAU	11,0	Y-501U	4187	31
Passat IV 2.5 TDI V6 4motion	3B3, 3B6	2.5	132	6	01.03-05.05	BDH	11,0	Y-501U	4187	31

PASSAT V

Passat V 1.6 TDI	3C2, 3C5	1.6	77	4	08.09-11.10	CAYC	4,4	Y1002AS	8888	57
Passat V 1.6 TDI	362	1.6	77	4	08.10-12.14	CAYC	4,4	Y1002AS	8888	57
Passat V 1.9 TDI	3C2, 3C5	1.9	77	4	03.05-02.06	BKC	5,0	Y-607AS	7560	50
Passat V 1.9 TDI	3C2, 3C5	1.9	77	4	06.05-05.07	BLS	5,0	Y-607AS	7560	50
Passat V 1.9 TDI	3C2, 3C5	1.9	77	4	02.06-11.08	BXE	5,0	Y-607AS	7560	50
Passat V 2.0 TDI	3C2, 3C5	2.0	81	4	11.08-12.11	CBDC	4,4	Y1002AS	8888	57
Passat V 2.0 TDI	3C2, 3C5	2.0	88	4	11.05-05.07	BWV	7,0	CZ304	9864	55
Passat V 2.0 TDI	3C2, 3C5	2.0	90	4	06.05-	BVD	7,0	CZ104	9826	52
Passat V 2.0 TDI	3C2, 3C5	2.0	90	4	06.05-02.06	BVE	7,0	CZ304	9864	55
Passat V 2.0 TDI (OE Ref N10579803)	3C2, 3C5	2.0	100	4	03.05-05.07	BMA	7,0	CZ304	9864	55
Passat V 2.0 TDI	3C2, 3C5	2.0	100	4	03.05-12.11	CBAA	4,4	Y1002AS	8888	49
Passat V 2.0 TDI (OE Ref N10579802)	3C2, 3C5	2.0	100	4	06.07-04.09	BMA	4,4	YE14	7768	48
Passat V 2.0 TDI	3C2, 3C5	2.0	100	4	08.10-12.14	CFFA	4,4	Y1002AS	8888	57
Passat V 2.0 TDI	3C2, 3C5	2.0	103	4	03.05-05.09	BMP	7,0	CZ104	9826	52





kw
C
Y
I



Stock-No
D-POWER

VOLKSWAGEN

PASSAT V

Passat V 2.0 TDI (OE Ref N10579803)	3C2, 3C5	2.0	103	4	03.05-05.07	BKP	7,0	CZ304	9864	55
Passat V 2.0 TDI	3C2, 3C5	2.0	103	4	03.05-11.11	CBAB	4,4	Y1002AS	8888	49
Passat V 2.0 TDI (OE Ref N10579802)	3C2, 3C5	2.0	103	4	06.07-11.10	BKP	4,4	YE14	7768	48
Passat V 2.0 TDI	3C2, 3C5	2.0	103	4	08.10-12.14	CFFB	4,4	Y1002AS	8888	57
Passat V 2.0 TDI TDi BlueMotion	365	2.0	103	4	08.10-12.14	CFFB	4,4	Y1002AS	8888	57
Passat V 2.0 TDI	3C2, 3C5	2.0	105	4	06.08-11.10	CBAC	4,4	Y1002AS	8888	57
Passat V 2.0 TDI	3C2, 3C5	2.0	120	4	10.05-05.09	BUZ	7,0	CZ304	9864	55
Passat V 2.0 TDI	3C2, 3C5	2.0	125	4	02.06-11.10	BMR	7,0	CZ304	9864	55
Passat V 2.0 TDI	3C2, 3C5	2.0	125	4	02.06-11.10	CBBB	4,4	Y1002AS	8888	49
Passat V 2.0 TDI	3C2, 3C5	2.0	125	4	08.10-	CFGB	4,4	Y1002AS	8888	57
Passat V 2.0 TDI	3C2, 3C5	2.0	125	4	08.10-12.14	CLLA	4,4	Y1002AS	8888	57
Passat V 2.0 TDI TDi BlueMotion	365	2.0	125	4	11.10-01.13	CFGB	4,4	Y1002AS	8888	57
Passat V 2.0 TDI	3C2, 3C5	2.0	130	4	12.12-12.14	CFGC	4,4	Y1002AS	8888	57

PASSAT VI

Passat VI 1.6 TDI (only for cyl. without pressure sensor)	3G2, 3G5	1.6	88	4	08.14-	DCXA	4,4	Y1002AS	8888	57
Passat VI 1.6 TDI (only for cyl. without pressure sensor)	3G2, 3G5	1.6	88	4	08.14-	DCZA	4,4	Y1002AS	8888	57
Passat VI 2.0 TDI (only for cyl. without pressure sensor)	3G2, 3G5	2.0	110	4	08.14-	CRLB	4,4	Y1002AS	8888	57
Passat VI 2.0 TDi BlueMotion (only for cyl. without pressure sensor)	3G5	2.0	110	4	05.15-	CRLB	4,4	Y1002AS	8888	57
Passat VI 2.0 TDI (only for cyl. without pressure sensor)	3G2, 3G5	2.0	140	4	11.14-	DDAA	4,4	Y1002AS	8888	57
Passat VI 2.0 TDi BlueMotion (only for cyl. without pressure sensor)	3G2	2.0	140	4	11.14-	DFCA	4,4	Y1002AS	8888	57
Passat VI 2.0 TDi BlueMotion (only for cyl. without pressure sensor)	3G5	2.0	140	4	05.15-	DDAA	4,4	Y1002AS	8888	57
Passat VI 2.0 BiTDI (only for cyl. without pressure sensor)	3G2, 3G5	2.0	176	4	08.14-	CUAA	4,4	Y1002AS	8888	57
Passat VI 2.0 BiTDI (only for cyl. without pressure sensor)	3G2, 3G5	2.0	176	4	08.14-	DBGA	4,4	Y1002AS	8888	57
Passat VI 2.0 TDi BlueMotion (only for cyl. without pressure sensor)	3G5	2.0	176	4	05.15-	CUAA	4,4	Y1002AS	8888	57
Passat VI 2.0 TDi BlueMotion (only for cyl. without pressure sensor)	3G5	2.0	176	4	05.15-	CUPA	4,4	Y1002AS	8888	57

PASSAT B5

Passat B5 1.9 TDi (color code: Black)	3B2	1.9	66	4	10.96-08.00	AHH	12,0	Y-918J	6285	2
Passat B5 1.9 TDi (color code: Black)	3B2	1.9	66	4	10.96-08.00	AHU	12,0	Y-918J	6285	2
Passat B5 1.9 TDi (color code: Black)	3B2	1.9	81	4	10.96-08.00	AFN	12,0	Y-918J	6285	2
Passat B5 1.9 TDi (color code: Black)	3B2	1.9	81	4	10.96-08.00	AVG	12,0	Y-918J	6285	2
Passat B5 1.9 TDi (color code: Black)	3B5	1.9	81	4	10.96-08.00	AVG	12,0	Y-918J	6285	2
Passat B5 1.9 TDi (color code: Black)	3B5	1.9	81	4	06.97-08.00	AVG	12,0	Y-918J	6285	2

PHAETON

Phaeton 3.0 V6 TDI	3D1, 3D4, 3D6, 3D9	3.0	176	6	06.08-	CARB	4,4	Y-609AS	5849	49
--------------------	--------------------	-----	-----	---	--------	------	-----	---------	------	----

PHAETON (3D2)

Phaeton 3.0 V6 TDI	3D2	3.0	165	6	09.04-05.07	BMK	4,4	Y-609AS	5849	49
Phaeton 3.0 V6 TDI	3D2	3.0	171	6	06.07-11.08	CARA	4,4	Y-609AS	5849	49
Phaeton 3.0 V6 TDI	3D2	3.0	176	6	05.08-05.10	CEXA	4,4	Y-609AS	5849	49
Phaeton 3.0 V6 TDI	3D2	3.0	180	6	11.13-	CEXB	4,4	Y1002AS	8888	57
Phaeton 5.0 V10 TDI	3D2	5.0	230	10	12.02-10.06	AJS	11,0	Y-741U	6943	20



e kW C
y
iStock-No
D-POWER™**VOLKSWAGEN****POLO II**

Passat II 1.4 D	86C	1.4	35	4	10.90-07.94	1W	12,0	Y-918J	6285	2
-----------------	-----	-----	----	---	-------------	----	------	--------	------	---

POLO III

Passat III 1.4 TDI	6N2	1.4	55	3	10.99-05.05	AMF	11,0	Y-741U	6943	20
Passat III 1.4 TDI	6N2	1.4	66	3	01.00-04.00	ATL	11,0	Y-741U	6943	20
Passat III 1.7 SDI	6N1	1.7	42	4	04.97-12.99	AHG	12,0	Y-732J	5605	4
Passat III 1.7 SDi (color code: Black)	6N1	1.7	42	4	04.97-10.99	AHG	12,0	Y-918J	6285	2
Passat III 1.7 SDI	6N1, 6N2	1.7	42	3	08.97-04.00	AKU	12,0	Y-732J	5605	4
Passat III 1.7 SDi (color code: Black)	6N1, 6N2	1.7	44	4	08.97-09.01	AKU	12,0	Y-918J	6285	2
Passat III 1.7 SDI Classic / Variant	6KV2, 6KV5	1.7	44	4	11.97-08.99	AKW	12,0	Y-732J	5605	4
Passat III 1.7 SDi (color code: Black)	6V2, 6V5	1.7	44	4	11.97-08.99	AKW	12,0	Y-918J	6285	2
Passat III 1.9 D	6N1, 6N2	1.9	47	4	10.94-12.99	AEF	12,0	Y-918J	6285	2
Passat III 1.9 -/SDi (color code: Black)	6N1, 6N2	1.9	47	4	10.94-09.01	AGD	12,0	Y-918J	6285	2
Passat III 1.9 -/SDi (color code: Black)	6N1, 6N2	1.9	47	4	10.94-09.01	ASX	12,0	Y-918J	6285	2
Passat III 1.9 SDI Classic / Variant	6KV2, 6KV5	1.9	47	4	12.95-08.99	AEY	12,0	Y-732J	5605	4
Passat III	6_	1.9	47	4	01.96-10.96	1Y	12,0	Y-918J	6285	2
Passat III 1.9 SDi (color code: Black)	6V5	1.9	47	4	05.96-08.99	AEY	12,0	Y-918J	6285	2
Passat III 1.9 SDI	6N1, 6N2	1.9	47	4	07.96-09.01	AGD	12,0	Y-732J	5605	4
Passat III 1.9 SDI	6N2	1.9	47	4	10.99-09.01	ASX	12,0	Y-732J	5605	4
Passat III 1.9 SDI Classic / Variant	6KV2, 6KV5	1.9	50	4	10.99-09.01	AGP	12,0	Y-732J	5605	4
Passat III 1.9 SDI Classic / Variant	6KV2, 6KV5	1.9	50	4	10.99-09.01	AQM	12,0	Y-732J	5605	4
Passat III 1.9 TDI Classic / Variant	6KV2, 6KV5	1.9	66	4	01.97-08.99	AHU	12,0	Y-732J	5605	4
Passat III 1.9 TDI Variant	6KV5	1.9	66	4	11.97-08.99	ALE	12,0	Y-732J	5605	4
Passat III 1.9 TDI Classic / Variant	6KV2, 6KV5	1.9	66	4	10.99-09.01	AGR	12,0	Y-732J	5605	4
Passat III 1.9 TDI Classic / Variant	6KV2, 6KV5	1.9	66	4	10.99-09.01	ALH	12,0	Y-732J	5605	4
Passat III 1.9 TDI Classic / Variant	6KV2, 6KV5	1.9	81	4	06.98-09.01	AFN	12,0	Y-732J	5605	4
Passat III 1.9 TDI Classic / Variant	6KV2, 6KV5	1.9	81	4	10.99-09.01	ASV	12,0	Y-732J	5605	4

POLO IV

Passat IV 1.4 TDI	9N	1.4	51	3	04.05-11.09	BNM	11,0	Y-741U	6943	20
Passat IV 1.4 TDI	9N	1.4	51	3	05.06-11.09	BWB	7,0	CZ104	9826	52
Passat IV 1.4 TDI	9N	1.4	55	3	11.01-05.05	BAY	11,0	Y-741U	6943	20
Passat IV 1.4 TDI	9N	1.4	59	3	04.05-11.09	BNV	11,0	Y-741U	6943	20
Passat IV 1.4 TDI	9N	1.4	59	3	10.05-11.09	BMS	7,0	CZ104	9826	52
Passat IV TDI	9N	1.6	55	4	06.09-	CAYA	4,4	Y1002AS	8888	57
Passat IV TDI	9N	1.6	66	4	06.09-05.14	CAYB	4,4	Y1002AS	8888	57
Passat IV TDI	9N	1.6	77	4	06.09-05.14	CAYC	4,4	Y1002AS	8888	57
Passat IV 1.9 SDI	9N	1.9	47	4	11.01-11.09	ASY	12,0	Y-732J	5605	4
Passat IV 1.9 TDI	9N	1.9	74	4	11.01-11.09	AXR	11,0	Y-741U	6943	20
Passat IV 1.9 TDI	9N	1.9	74	4	11.01-11.09	ATD	11,0	Y-741U	6943	20
Passat IV 1.9 TDI (Ceramic GP)	9N	1.9	74	4	05.06-11.09	BMT	7,0	CZ104	9826	52
Passat IV 1.9 TDI (Metal GP)	9N	1.9	74	4	05.06-11.09	BMT	5,0	Y-607AS	7560	50
Passat IV 1.9 TDI	9N	1.9	96	4	11.03-11.09	ASZ	11,0	Y-741U	6943	20
Passat IV 1.9 TDI	9N	1.9	96	4	05.04-11.09	BLT	11,0	Y-741U	6943	20

POLO V

Passat V 1.2 TDI	6R	1.2	55	3	10.09- .14	CFWA	4,4	Y1002AS	8888	57
Passat V 1.4 TDI (only for cyl. without pressure sensor)	6R	1.4	55	3	03.14-	CUSA	4,4	Y1002AS	8888	57





l kW C
Y I



Stock-No
D-POWER

VOLKSWAGEN

POLO V

Passat V 1.4 TDI (only for cyl. without pressure sensor)	6R	1.4	55	3	03.14-	CYZB	4,4	Y1002AS	8888	57
Passat V 1.4 TDI (only for cyl. without pressure sensor)	6R	1.4	66	3	03.14-	CUSB	4,4	Y1002AS	8888	57
Passat V 1.4 TDI (only for cyl. without pressure sensor)	6R	1.4	77	3	03.14-	CUTA	4,4	Y1002AS	8888	57
Passat V 1.6 TDI	6R	1.6	55	4	05.09- .14	CAYA	4,4	Y1002AS	8888	57
Passat V 1.6 TDI	6R	1.6	66	4	06.09- .14	CAYB	4,4	Y1002AS	8888	57
Passat V 1.6 TDI	6R	1.6	77	4	05.09- .14	CAYC	4,4	Y1002AS	8888	57
Passat V 1.6 TDI	6R	1.6	77	4	05.09- .14	CLNA	4,4	Y1002AS	8888	57

SCIROCCO III (137)

Scirocco III 2.0 TDI	137	2.0	100	4	11.10-05.14	CFHB	4,4	Y1002AS	8888	57
Scirocco III 2.0 TDI	137	2.0	100	4	11.10-05.14	CFHC	4,4	Y1002AS	8888	57
Scirocco III 2.0 TDI	137	2.0	125	4	05.09-05.14	CFGB	4,4	Y1002AS	8888	57
Scirocco III 2.0 TDI	137	2.0	103	4	08.08-	CBDB	4,4	Y1002AS	8888	57
Scirocco III 2.0 TDI	137	2.0	125	4	05.09-	CBBB	4,4	Y1002AS	8888	57
Scirocco III 2.0 TDI	137	2.0	130	4	01.13-	CFGC	4,4	Y1002AS	8888	57

SCIROCCO IV (138)

Scirocco IV 2.0 TDi BlueMotion Cylinder (only for cyl. without pressure sensor)	138	2.0	110	4	11.13-	CUUB	4,4	Y1002AS	8888	57
Scirocco IV 2.0 TDi BlueMotion Cylinder (only for cyl. without pressure sensor)	138	2.0	132	4	11.13-	CUXA	4,4	Y1002AS	8888	57
Scirocco IV 2.0 Tdi/ BlueMotion DI Cylinder (only for cyl. without pressure sensor)	138	2.0	135	4	05.14-	CUWA	4,4	Y1002AS	8888	57

SHARAN I

Sharan I 1.9 TDI	7M6, 7M8, 7M9	1.9	66	4	09.95-03.96	1Z	12,0	Y-732J	5605	4
Sharan I 1.9 TDI	7M6, 7M8, 7M9	1.9	66	4	08.96-02.00	AHU	12,0	Y-732J	5605	4
Sharan I 1.9 TDI	7M6, 7M8, 7M9	1.9	66	4	03.99-03.00	ANU	11,0	Y-741U	6943	20
Sharan I 1.9 TDI	7M8	1.9	81	4	02.96-02.00	AFN	12,0	Y-732J	5605	4
Sharan I 1.9 TDI	7M8	1.9	81	4	08.99-02.00	AVG	12,0	Y-732J	5605	4

SHARAN II

Sharan II 1.9 TDI	7M6, 7M9	1.9	85	4	04.00-03.10	AUY	11,0	Y-741U	6943	20
Sharan II 1.9 TDI	7M6, 7M9	1.9	85	4	11.05-03.10	BVK	11,0	Y-741U	6943	20
Sharan II 1.9 TDI	7M6, 7M9	1.9	96	4	11.02-03.10	ASZ	11,0	Y-741U	6943	20
Sharan II 1.9 TDI	7M6	1.9	110	4	01.05-05.07	BTB	11,0	Y-741U	6943	20
Sharan II 2.0 TDI	7M6	2.0	100	4	11.05-03.10	BVH	7,0	CZ104	9826	52
Sharan II 2.0 TDI	7M6	2.0	103	4	11.05-03.10	BRT	7,0	CZ104	9826	52

SHARAN III

Sharan III 2.0 TDI BlueMotion	7N1, 7N2	2.0	85	4	05.11-	CUVA	4,4	Y1002AS	8888	57
Sharan III 2.0 TDI	7N1	2.0	85	4	06.11-	CFFE	4,4	Y1002AS	8888	57
Sharan III 2.0 TDI	7N1	2.0	100	4	05.10-	CFFA	4,4	Y1002AS	8888	57
Sharan III 2.0 TDI	7N1	2.0	103	4	05.10-	CFFB	4,4	Y1002AS	8888	57
Sharan III 2.0 TDI (only for cyl. without pressure sensor)	7N1	2.0	110	4	.15-	CUVC	4,4	Y1002AS	8888	57
Sharan III 2.0 TDI	7N1	2.0	125	4	08.10-	CFGB	4,4	Y1002AS	8888	57
Sharan III 2.0 TDI	7N1	2.0	130	4	01.13-	CFGC	4,4	Y1002AS	8888	57
Sharan III 2.0 TDI (only for cyl. without pressure sensor)	7N1	2.0	135	4	.15-	CUWA	4,4	Y1002AS	8888	57





e kW C
y
i



Stock-No
D-POWER™

VOLKSWAGEN

T 3

T 3 1.7 D	1.7	42	4	10.86-07.92	KY	12,0	Y-918J	6285	2
-----------	-----	----	---	-------------	----	------	--------	------	---

T 4

T 4 D	1.9	44	4	09.90-12.95	1X	12,0	Y-918J	6285	2
T 4 TD	1.9	50	4	10.92-04.02	ABL	12,0	Y-918J	6285	2
T 4	2.4	55	5	04.97-06.03	AJA	12,0	Y-918J	6285	2
T 4 D	2.4	57	5	09.90-04.98	AAB	12,0	Y-918J	6285	2
T 4	2.5	65	5	05.98-09.03	AJT	12,0	Y-732J	5605	4
T 4	2.5	65	5	10.01-09.03	AYY	12,0	Y-732J	5605	4
T 4 TDI	2.5	75	5	09.95-06.03	ACV	12,0	Y-732J	5605	4
T 4	2.5	75	5	11.99-09.03	AUF	12,0	Y-732J	5605	4
T 4	2.5	75	5	04.01-09.03	AXL	12,0	Y-732J	5605	4
T 4 TDI	2.5	75	5	04.01-09.03	AYC	12,0	Y-732J	5605	4
T 4	2.5	111	5	07.99-09.00	AHY	12,0	Y-732J	5605	4
T 4 TDI	2.5	111	5	09.00-09.03	AXG	12,0	Y-732J	5605	4

T 5

T 5 1.9 TDI	1.9	62	4	01.06-	BRR	5,0	Y-607AS	7560	50	
T 5 1.9 TDI	1.9	63	4	04.03-05.07	AXC	11,0	Y-741U	6943	20	
T 5 1.9 TDI	1.9	75	4	01.06-	BRS	5,0	Y-607AS	7560	50	
T 5 1.9 TDI	1.9	77	4	04.03-05.07	AXB	11,0	Y-741U	6943	20	
T 5 2.0 TDI	2.0	84	4	05.11-08.15	CAAD	4,4	Y1002AS	8888	57	
T 5 2.0 TDI	2.0	100	4	05.10-08.15	CAAE	4,4	Y1002AS	8888	57	
T 5 2.0 TDI	2.0	100	4	05.10-08.15	CCHB	4,4	Y1002AS	8888	57	
T 5 2.0 TDI	2.0	103	4	08.09-08.15	CCHA	4,4	Y1002AS	8888	57	
T5 2.0 TDi/TDi BlueMotion	7EC, 7EF, 7EG	2.0	132	4	09.09-08.15	CFCA	4,4	Y1002AS	8888	57
T 5 2.5 TDI	2.5	96	5	05.07-11.09	BNZ	7,0	CZ104	9826	52	
T 5 2.5 TDI	2.5	96	5	05.07-11.09	AXD	11,0	Y-741U	6943	20	
T 5 2.5 TDI	2.5	120	5	05.07-11.09	BLJ	11,0	Y-741U	6943	20	
T 5 2.5 TDI	2.5	128	5	05.07-11.09	BPC	7,0	CZ104	9826	52	
T 5 2.5 TDI	2.5	128	5	05.07-11.09	AXE	11,0	Y-741U	6943	20	

T5

T5 2.0 Tdi BlueMotion	7EF, 7EG	2.0	62	4	09.09-08.15	CAAA	4,4	Y1002AS	8888	57
T5 2.0 TDi	7EC, 7EF, 7EG	2.0	75	4	08.09-08.15	CAAB	4,4	Y1002AS	8888	57

T5 2.0

T5 2.0 TDi/TDi BlueMotion	7EC, 7EF, 7EG	2.0	103	4	10.09-08.15	CAAC	4,4	Y1002AS	8888	57
---------------------------	---------------	-----	-----	---	-------------	------	-----	---------	------	----

TIGUAN (5N)

Tiguan 2.0 TDI	5N	2.0	81	4	05.10-	CFFD	4,4	Y1002AS	8888	57
Tiguan 2.0 TDI für (only for cyl. without pressure sensor)	5N	2.0	81	4	05.15-	CUVE	4,4	Y1002AS	8888	57
Tiguan 2.0 TDI	5N	2.0	100	4	11.07-05.10	CBAA	4,4	Y1002AS	8888	57
Tiguan 2.0 TDI	5N	2.0	100	4	05.10-	CFFA	4,4	Y1002AS	8888	57
Tiguan 2.0 TDI	5N	2.0	103	4	11.07-	CBAB	4,4	Y1002AS	8888	57
Tiguan 2.0 TDI	5N	2.0	103	4	11.09-	CFFB	4,4	Y1002AS	8888	57
Tiguan 2.0 TDI	5N	2.0	103	4	11.10-	CLJA	4,4	Y1002AS	8888	57
Tiguan 2.0 TDI für (only for cyl. without pressure sensor)	5N	2.0	110	4	05.15-	CUVC	4,4	Y1002AS	8888	57
Tiguan 2.0 TDI	5N	2.0	120	4	02.08-05.10	CBBA	4,4	Y1002AS	8888	57





e kW C
y I



Stock-No
D-POWER

VOLKSWAGEN

TIGUAN (5N)

Tiguan 2.0 TDI	5N	2.0	125	4	02.08-07.09	CBBB	4,4	Y1002AS	8888	57
Tiguan 2.0 TDI	5N	2.0	125	4	05.10-	CFGB	4,4	Y1002AS	8888	57
Tiguan 2.0 TDI	5N	2.0	130	4	11.12-	CFGC	4,4	Y1002AS	8888	57
Tiguan 2.0 TDI	5N	2.0	135	4	05.15-	CUWA	4,4	Y1002AS	8888	57

TOUAREG

Touareg Tdi/ BlueMotion	7P5, 7P6	3.0	150	6	01.10-	CASD	4,4	Y-609AS	5849	49
Touareg TDi/ BlueMotion	7P5	3.0	176	6	01.10-12.14	CNRB	4,4	Y1002AS	8888	57

TOUAREG I

Touareg I 2.5 TDI	7LA, 7L6, 7L7	2.5	120	5	07.03-11.06	BLK	11,0	Y-741U	6943	20
Touareg I 2.5 TDI	7LA, 7L6, 7L7	2.5	120	5	01.06-05.10	BPD	7,0	CZ104	9826	52
Touareg I 2.5 TDI	7LA, 7L6, 7L7	2.5	128	5	01.03-11.06	BAC	11,0	Y-741U	6943	20
Touareg I 2.5 TDI	7LA, 7L6, 7L7	2.5	128	5	01.06-05.10	BPE	7,0	CZ104	9826	52
Touareg I 3.0 TDI	7LA, 7L6, 7L7	3.0	150	6	05.11-	CJMA	4,4	Y1002AS	8888	57
Touareg I 3.0 TDI	7LA, 7L6, 7L7	3.0	155	6	04.06-11.07	BUN	4,4	Y-609AS	5849	49
Touareg I 3.0 TDI	7LA, 7L6, 7L7	3.0	155	6	11.07-05.10	CASB	4,4	Y-609AS	5849	49
Touareg I 3.0 TDI	7LA, 7L6, 7L7	3.0	165	6	11.04-05.08	BKS	4,4	Y-609AS	5849	49
Touareg I 3.0 TDI (only for cyl. without pressure sensor)	7LA, 7L6, 7L7	3.0	165	6	05.10-	CATA	4,4	Y1002AS	8888	57
Touareg I 3.0 TDI	7LA, 7L6, 7L7	3.0	176	6	01.08-05.10	CASC	4,4	Y-609AS	5849	49
Touareg I 3.0 TDI	7LA, 7L6, 7L7	3.0	177	6	11.07-05.10	CASA	4,4	Y-609AS	5849	49
Touareg I 5.0 V10 TDI	7LA, 7L6, 7L7	5.0	230	10	11.02-11.06	AYH	11,0	Y-741U	6943	20
Touareg I 5.0 V10 TDI	7LA, 7L6, 7L7	5.0	230	10	11.04-05.10	BLE	7,0	CZ104	9826	52
Touareg I 5.0 V10 TDI	7LA, 7L6, 7L7	5.0	258	10	08.07-	CBWA	7,0	CZ104	9826	52

TOUAREG II

Touareg II 3.0 TDI (only for cyl. without pressure sensor)	7P5	3.0	165	6	05.12-	CATA	4,4	Y1002AS	8888	57
Touareg II 3.0 TDI	7P5	3.0	180	6	05.11-	CJGD	4,4	Y1002AS	8888	57
Touareg II 3.0 TDI	7P5	3.0	180	6	05.11-	CRCA	4,4	Y1002AS	8888	57
Touareg II 4.2 V8 TDI	7P5	4.2	250	8	01.10-	CKDA	4,4	Y1002AS	8888	57

TOUAREG III

Touareg III 3.0 TDI	7P6	3.0	193	6	08.14-	CVWA	4,4	Y1002AS	8888	57
---------------------	-----	-----	-----	---	--------	------	-----	---------	------	----

TOURAN I

Touran I 1.6 TDI	1T3	1.6	66	4	05.10- .15	CAYB	4,4	Y1002AS	8888	57
Touran I 1.6 TDI	1T3	1.6	77	4	05.10- .15	CAYC	4,4	Y1002AS	8888	57
Touran I 1.9 TDI	1T1, 1T2	1.9	66	4	11.04-02.06	BRU	5,0	Y-607AS	7560	50
Touran I 1.9 TDI	1T1, 1T2	1.9	66	4	02.06-05.10	BXF	5,0	Y-607AS	7560	50
Touran I 1.9 TDI	1T1, 1T2	1.9	66	4	06.06-05.10	BXJ	5,0	Y-607AS	7560	50
Touran I 1.9 TDI	1T1	1.9	74	4	02.03-05.04	AVQ	5,0	Y-607AS	7560	50
Touran I 1.9 TDI	1T1, 1T2	1.9	77	4	08.03-02.06	BKC	5,0	Y-607AS	7560	50
Touran I 1.9 TDI	1T1, 1T2	1.9	77	4	06.05-05.10	BLS	5,0	Y-607AS	7560	50
Touran I 1.9 TDI	1T1, 1T2	1.9	77	4	02.06-05.10	BXE	5,0	Y-607AS	7560	50
Touran I 2.0 TDI	1T3	2.0	81	4	05.10-	CLCA	4,4	Y1002AS	8888	57





e kW C
y
i



Stock-No
D-POWER

VOLKSWAGEN

TOURAN I

Touran I 2.0 TDI	1T1, 1T2	2.0	100	4	02.03-05.10	AZV	4,4	YE14	7768	48
Touran I 2.0 TDI	1T1, 1T2	2.0	103	4	08.03-05.10	BKD	4,4	YE14	7768	48
Touran I 2.0 TDI	1T1, 1T2	2.0	103	4	12.05-05.10	BMM	5,0	Y-607AS	7560	50
Touran I 2.0 TDI	1T3	2.0	103	4	05.10-	CFHC	4,4	Y1002AS	8888	57
Touran I 2.0 TDI	1T1, 1T2	2.0	125	4	12.05-05.10	BMN	7,0	CZ304	9864	55
Touran I 2.0 TDI	1T3	2.0	125	4	05.10-01.13	CFJA	4,4	Y1002AS	8888	57
Touran II 2.0 TDI	1T3	2.0	130	4	01.13- .15	CFJB	4,4	Y1002AS	8888	57

TOURAN II

Touran II 2.0 TDI	1T3	2.0	81	4	05.10-05.15	CFHF	4,4	Y1002AS	8888	57
Touran II 1.6 TDI (only for cyl. without pressure sensor)		1.6	81	4	.15-	CRKB	4,4	Y1002AS	8888	57

TOURAN III

Touran III 2.0 TDI (only for cyl. without pressure sensor)		2.0	110	4	.15-	DFEA	4,4	Y1002AS	8888	57
Touran III 2.0 TDI (only for cyl. without pressure sensor)		2.0	140	4	.15-	DFHA	4,4	Y1002AS	8888	57

TRANSPORTER

Transporter TDI		2.0	62	4	09.09-	CAAA	4,4	Y1002AS	8888	57
Transporter TDI		2.0	75	4	09.09-	CAAB	4,4	Y1002AS	8888	57
Transporter TDI		2.0	84	4	05.11-	CAAD	4,4	Y1002AS	8888	57
Transporter TDI		2.0	100	4	05.10-	CAAE	4,4	Y1002AS	8888	57
Transporter TDI		2.0	100	4	05.10-	CCHB	4,4	Y1002AS	8888	57
Transporter TDI		2.0	103	4	09.09-	CAAC	4,4	Y1002AS	8888	57
Transporter TDI		2.0	103	4	09.09-	CCHA	4,4	Y1002AS	8888	57
Transporter TDI		2.0	132	4	09.09-	CFCA	4,4	Y1002AS	8888	57

VENTO

Vento 1.9 SDI	1H2	1.9	47	4	07.95-12.97	AEY	12,0	Y-732J	5605	4
Vento 1.9 D	1H2	1.9	48	4	01.92-12.97	1Y	12,0	Y-918J	6285	2
Vento 1.9 TD	1H2	1.9	55	4	01.92-12.97	AAZ	12,0	Y-918J	6285	2
Vento 1.9 TDI	1H2	1.9	66	4	07.93-07.96	1Z	12,0	Y-732J	5605	4
Vento 1.9 TDI	1H2	1.9	66	4	05.96-12.01	ALE	12,0	Y-732J	5605	4
Vento 1.9 TDI	1H2	1.9	66	4	08.96-12.97	AHU	12,0	Y-732J	5605	4
Vento 1.9 TDI	1H2	1.9	81	4	02.96-12.97	AFN	12,0	Y-732J	5605	4
Vento 1.9 SDi (color code: Black)	1H2	1.9	47	4	08.95-12.97	AEY	12,0	Y-918J	6285	2

VOLVO

240

240 D		2.4	60	4	08.79-08.93	D 24	12,0	Y-918J	6285	2
-------	--	-----	----	---	-------------	------	------	--------	------	---

340

340 D		1.6	40	4	09.84-07.91	D 16	11,0	Y-913J	5317	15
-------	--	-----	----	---	-------------	------	------	--------	------	----

360

360 D		1.6		4	07.84-	D 16	11,0	Y-913J	5317	15
-------	--	-----	--	---	--------	------	------	--------	------	----

440

440 TD		1.9	66	4	01.93-12.96	Renault F8Q Turbo	11,0	Y-933J	7947	25
--------	--	-----	----	---	-------------	-------------------	------	--------	------	----

460

460 TD		1.9	66	4	06.94-08.97	D 19 T	11,0	Y-933J	7947	25
--------	--	-----	----	---	-------------	--------	------	--------	------	----

740

740 D		2.4	60	6	04.84-07.92	D 24	12,0	Y-918J	6285	2
-------	--	-----	----	---	-------------	------	------	--------	------	---





l kW C
y I



Stock-No
D-POWER

VOLVO

740

740 TD	2.4	80	6	04.87-07.92	D 24 T	12,0	Y-918J	6285	2
740 TD (air condition)	2.4	85	6	08.87-07.92	D 24 TIC	12,0	Y-918J	6285	2

760

760 TD	2.4	85	6	08.87-07.92	D 24 TIC	12,0	Y-918J	6285	2
--------	-----	----	---	-------------	----------	------	--------	------	---

780

780 TD	2.4	85	6	08.85-	D 24 TIC	12,0	Y-918J	6285	2
--------	-----	----	---	--------	----------	------	--------	------	---

940

940 TD	2.4	80	6	09.90-08.93	D 24 T	12,0	Y-918J	6285	2
940 GL, GLE TD	2.4	85	6	09.90-	D 24 TIC	12,0	Y-918J	6285	2
940 TD Interc., Kombi	2.4	90	6	01.94-	D 24 T	12,0	Y-918J	6285	2

960

960 TD Interc.	2.4	85	6	09.91-	D 24 TIC	12,0	Y-918J	6285	2
----------------	-----	----	---	--------	----------	------	--------	------	---

C 30

C 30 1.6 D	1.6	80	4	11.06-	D4164T	11,0	YE04	1684	40
C 30 2.0 D	2.0	100	4	11.06-	D4204T	11,0	Y1005J	7957	56
C 30 D 5 (Chassis No→62745)	2.4	120	5	11.06-07.10	D5244T9	4,4	Y8008AS	91440	74
C 30 D 5 (Chassis No→62745)	2.4	132	5	11.06-07.10	D5244T8, T13	4,4	Y8008AS	91440	74

C 70 2

C 70 2.0 D	2.0	100	4	03.07-	D4204T	11,0	Y1005J	7957	56
C 70 D5 (Chassis No→49640)	2.4	132	5	03.06-	D5244T8, T13	4,4	Y8008AS	91440	74

S 40 1

S 40 1.9D	1.9	66	4	07.95-08.99	D4192T	11,0	Y-933J	7947	25
S 40 1.9D	1.9	75	4	07.00-12.03	D4192T4, Di	12,0	Y-732J	5605	4
S 40 1.9D	1.9	85	4	07.00-12.03	D4192T3, DI	12,0	Y-732J	5605	4

S 40 2

S 40 II 1.6 D (Engine No→16125)	1.6	81	4	01.05-12.11	D4164T	11,0	YE04	1684	40
S 40 II 1.6 D (Engine No 16126→)	1.6	81	4	01.05-12.11	D4164T	11,0	YE05	91322	73
S 40 II 2.0 D	2.0	98	4	07.05-12.06	D4204T2	11,0	Y1005J	7957	56
S 40 II 2.0 D	2.0	100	4	01.04-09.10	D4204T	11,0	Y1005J	7957	56
S 40 II 2.4 D5 (Chassis No→380303)	2.4	132	5	03.06-07.10	D5244T8	4,4	Y8008AS	91440	74

S 60 1

S 60 2.4 D (For OE-No. 8653880)	2.4	93	5	09.05-03.10	D5244T7	4,4	Y8008AS	91440	74
S 60 2.4 D	2.4	96	5	12.01-	D5244T2	11,0	YE12	7794	
S 60 2.4 D	2.4	120	5	07.01-	D5244T	11,0	YE12	7794	
S 60 2.4 D (For OE-No. 8653880)	2.4	120	5	01.07-03.10	D5244T5	4,4	Y8008AS	91440	74
S 60 2.4 D5 (For OE-No. 8653880)	2.4	136	5	09.05-03.10	D5244T4	4,4	Y8008AS	91440	74

S 60 II

S 60 II D3 (For OE-No. 8653880)	2.0	100	5	05.12-	D5204T7	4,4	Y8008AS	91440	74
S 60 II D5 (For OE-No. 8653880)	2.4	151	5	04.10-07.11	D5244T10	4,4	Y8008AS	91440	74
S 60 II D5 (For OE-No. 8653880)	2.4	158	5	06.11-	D5244T11, T15	4,4	Y8008AS	91440	74

S 70

S 70	2.5	103	5	01.97-	D5252T	12,0	Y-732J	5605	4
S 70 2.5 TDi	2.5	103	5	01.97-	D5252 (Audi)	12,0	Y-732J	5605	4

S 80 I

S 80 2.4 D	2.4	96	5	10.01-07.06	D5244T2	11,0	YE12	7794	
------------	-----	----	---	-------------	---------	------	------	------	--





e kW C
y i



Stock-No
D-POWER

VOLVO

S 80 I

S 80 2.4 D	2.4	120	5	08.01-07.06	D5244T	11,0	YE12	7794	
S 80 2.5 D	2.5	103	5	01.99-07.06	D5252T	12,0	Y-732J	5605	4

S 80 II

S 80 II 2.0 D	AS	2.0	100	4	11.07-	D4204T	11,0	Y1005J	7957	56
S 80 II 2.4 D (For OE-No. 8653880)	AS	2.4	120	5	03.06-03.11	D5244T5, T19	4,4	Y8008AS	91440	74
S 80 II D5 (For OE-No. 8653880)	AS	2.4	136	5	03.06-05.09	D5244T4	4,4	Y8008AS	91440	74

V 40 1

V 40 1.9 D	VW	1.9	66	4	02.96-06.04	D4192T	11,0	Y-933J	7947	25
V 40 1.9 DI	VW	1.9	70	4	03.99-07.00	D4192T2	11,0	Y-740U	4818	22
V 40 1.9 D	VW	1.9	75	4	07.00-06.04	D4192T4, DI	12,0	Y-732J	5605	4
V 40 1.9 D	VW	1.9	85	4	07.00-06.04	D4192T3, DI	12,0	Y-732J	5605	4
V 40 1.9 DCI	VW	1.9		4	07.00-06.04	dCi Renault	12,0	Y-732J	5605	4

V 50

V 50 1.6 D (Chassis No→16125)	MW	1.6	80	4	01.05-	D4164T	11,0	YE04	1684	40
V 50 1.6 D (Chassis No 16126→)	MW	1.6	80	4	01.05-	D4164T	11,0	YE05	91322	73
V 50 2.0 D	MW	2.0	98	4	07.05-12.06	D4204T2	11,0	Y1005J	7957	56
V 50 2.0 D	MW	2.0	100	4	04.04-09.10	D4204T	11,0	Y1005J	7957	56
V 50 2.4 D (Chassis No→396178)	MW	2.4	120	5	05.07-09.10	D5244T9	4,4	Y8008AS	91440	74
V 50 2.4 D5 (Chassis No→396178)	MW	2.4	132	5	03.06-	D5244T8, T13	4,4	Y8008AS	91440	74

V 60

V 60 D3 (For OE-No. 8653880)		2.0	100	5	12.12-	D5204T7	4,4	Y8008AS	91440	74
V 60 D4 AWD (For OE-No. 8653880)		2.4	120	5	12.12-	D5244T17	4,4	Y8008AS	91440	74
V 60 D5 (For OE-No. 8653880)		2.4	151	5	09.10-	D5244T10	4,4	Y8008AS	91440	74
V 60 2.4 D5 (For OE-No. 8653880)		2.4	158	5	06.11-	D5244T11, T15	4,4	Y8008AS	91440	74

V 70 1

V 70 2.5 D		2.5	103	5	01.97-03.00	D5252T	12,0	Y-732J	5605	4
------------	--	-----	-----	---	-------------	--------	------	--------	------	---

V 70 2

V 70 II 2.4 D (For OE-No. 8653880)		2.4	93	5	05.05-07.07	D5244T7	4,4	Y8008AS	91440	74
V 70 II 2.4 D		2.4	96	5	12.01-	D5244T2	11,0	YE12	7794	
V 70 II 2.4 D5		2.4	120	5	08.01-07.06	D5244T	11,0	YE12	7794	
V 70 II 2.4 D5 (For OE-No. 8653880)		2.4	120	5	08.06-07.07	D5244T5	4,4	Y8008AS	91440	74
V 70 II 2.4 D5 (For OE-No. 8653880)		2.4	136	5	12.05-07.07	D5244T4	4,4	Y8008AS	91440	74

V 70 3

V 70 III 2.0 D		2.0	100	4	08.07-12.10	D4204T	11,0	Y1005J	7957	56
V 70 III 2.4 D (For OE-No. 8653880)		2.4	120	5	08.07-	D5244T5	4,4	Y8008AS	91440	74
V 70 III 2.4 D (For OE-No. 8653880)		2.4	129	5	05.09-12.10	D5244T14	4,4	Y8008AS	91440	74
V 70 III D5 (For OE-No. 8653880)		2.4	136	5	08.07-	D5244T4	4,4	Y8008AS	91440	74
V 70 III D5 (For OE-No. 8653880)		2.4	158	5	06.11-	D5244T11, T15	4,4	Y8008AS	91440	74

XC 60

XC60 2.4 D (Euro 3 / Euro 4)		2.4	120	5	05.08-	D5244T5, T16	4,4	Y8008AS	91440	74
XC60 2.4 D (Euro 3 / Euro 4)		2.4	129	5	05.09-12.10	D5244T14	4,4	Y8008AS	91440	74
XC60 D5 AWD (Euro 3 / Euro 4)		2.4	136	5	05.08-12.09	D5244T4	4,4	Y8008AS	91440	74
XC60 D5 AWD (Euro 3 / Euro 4)		2.4	151	5	05.09-	D5244T10	4,4	Y8008AS	91440	74

XC 70 1

XC70 2.4D5		2.4	120	5	09.02-	D5244T5	11,0	YE12	7794	
------------	--	-----	-----	---	--------	---------	------	------	------	--





l kW C
y
i



Stock-No
D-POWER

VOLVO

XC 70 1

XC70 2.4 D5 AWD (For OE-No. 8653880)	2,4	136	5	05.05-07.07	D5244T4	4,4	Y8008AS	91440	74
--------------------------------------	-----	-----	---	-------------	---------	-----	---------	-------	----

XC 70 2

XC70 II 2.4 D AWD (For OE-No. 8653880)	2,4	120	5	08.07-	D5244T5, T16	4,4	Y8008AS	91440	74
XC70 II 2.4 D (For OE-No. 8653880)	2,4	129	5	01.10-12.10	D5244T14	4,4	Y8008AS	91440	74
XC70 II D5 AWD (For OE-No. 8653880)	2,4	136	5	08.07-	D5244T4	4,4	Y8008AS	91440	74
XC70 II D5 AWD (For OE-No. 8653880)	2,4	158	5	06.11-	D5244T11, T15	4,4	Y8008AS	91440	74

XC 90

XC90 D5	2,4	120	5	02.03-	D5244T	11,0	YE12	7794	
XC90 D5 (For OE-No. 8653880)	2,4	120	5	03.11-	D5244T5	4,4	Y8008AS	91440	74
XC90 D5 (For OE-No. 8653880)	2,4	136	5	05.05-	D5244T4	4,4	Y8008AS	91440	74
XC90 D5 (For OE-No. 8653880)	2,4	147	5	11.10-	D5244T18	4,4	Y8008AS	91440	74



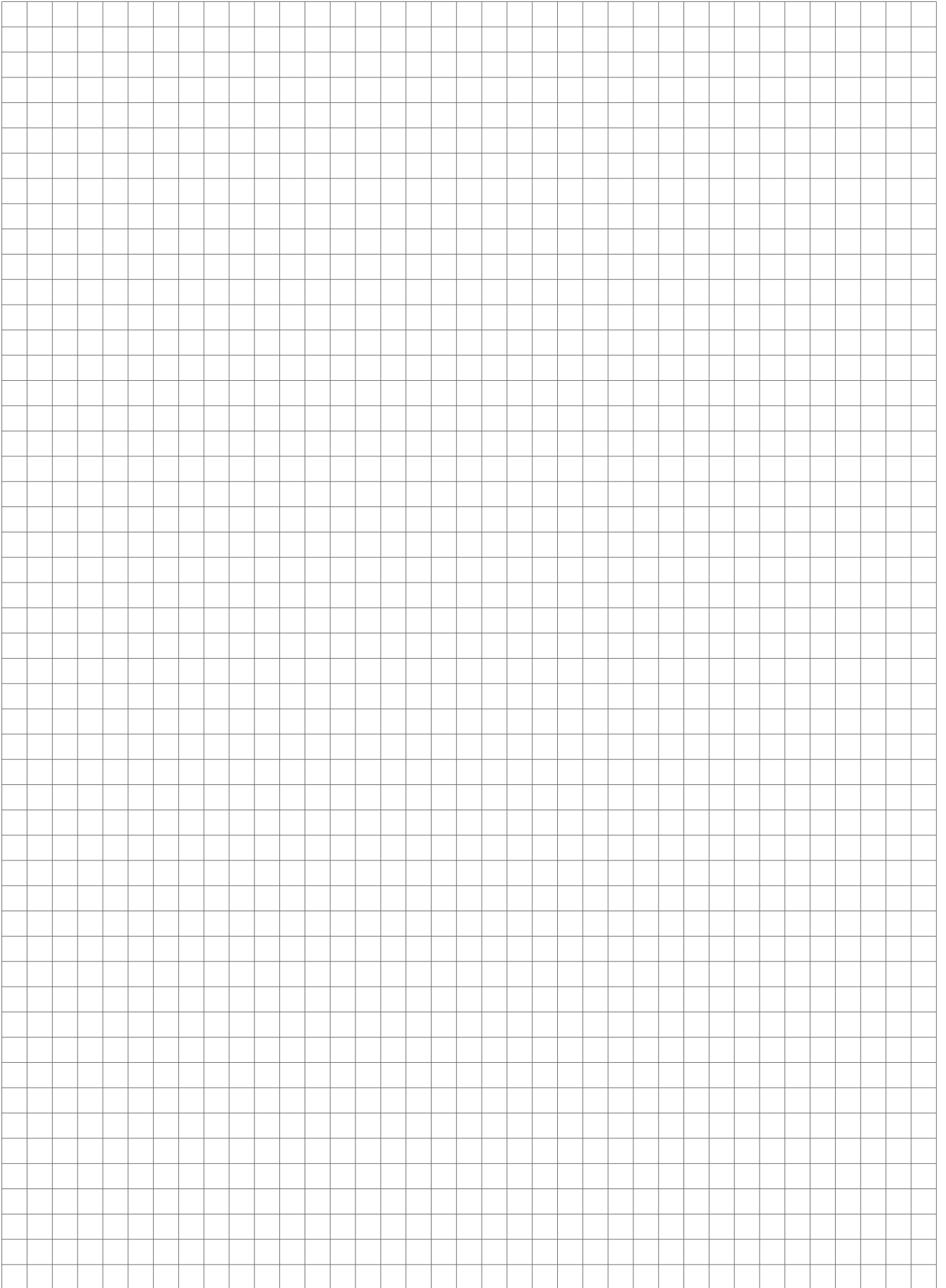

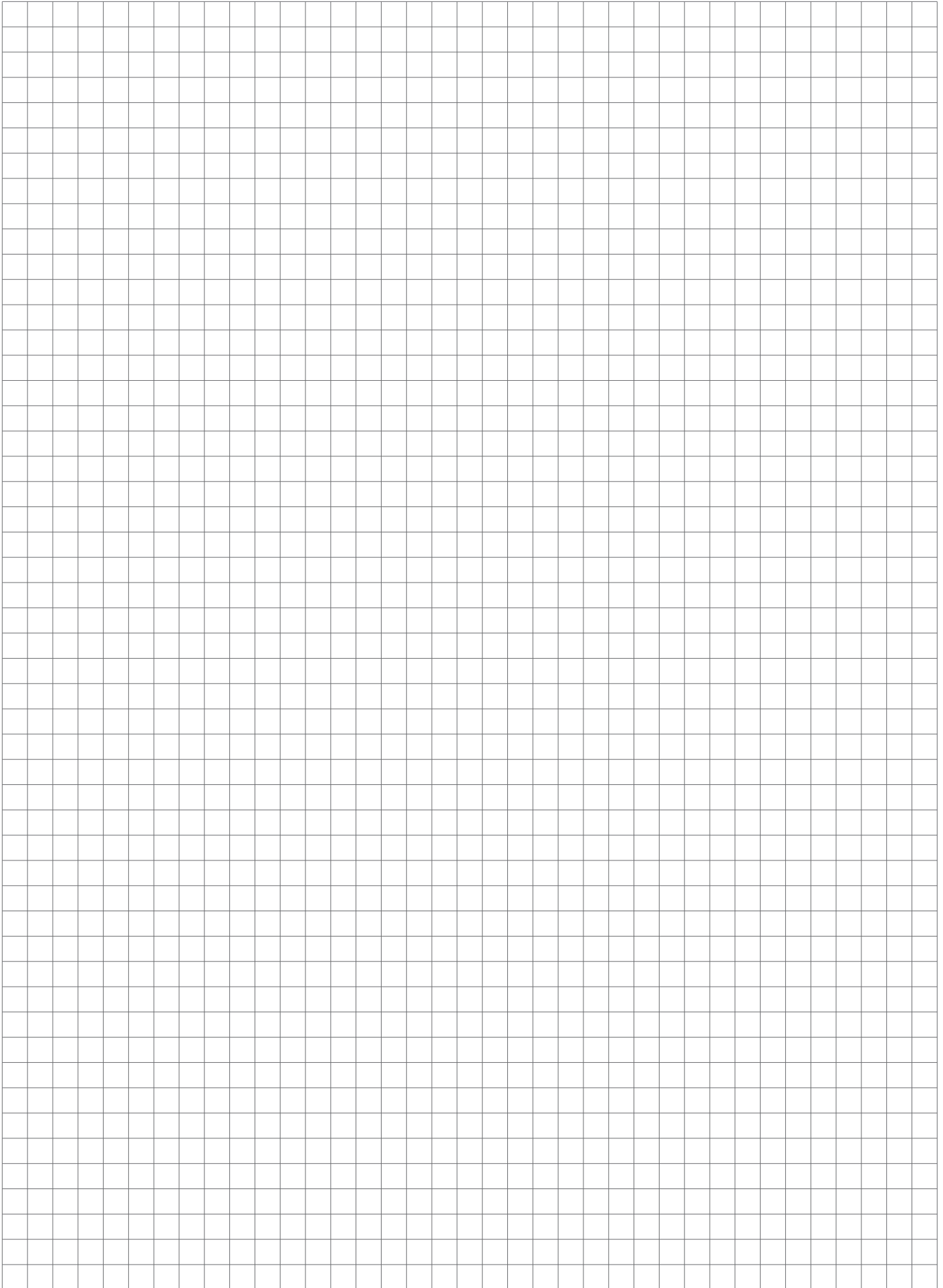



CROSS REFERENCE GUIDE

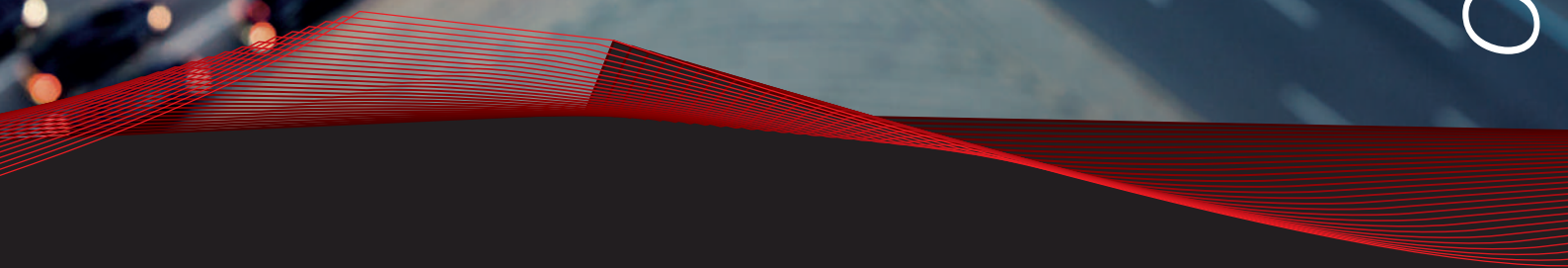

IGNITION
PARTS

ASTON MARTIN	→ NGK	V-Line
710 056	IFR7N10	
723 116	BCPR6E	12
2W93-12405-CCA	IFR7N10	
2W93-12405-CCB	IFR7N10	
6G430710056PK	IFR7N10	
CD3312405AA	SITR7A11G	
CD3312405AAPK	SITR7A11G	
BMW	→ NGK	V-Line
12 12 0 022 902	DCPR8EKP	
12 12 0 030 548	BKR6EQUP	30
12 12 0 031 708	BKR7EQUP	
12 12 0 032 134	IZFR6H11	
12 12 0 032 136	BKR6EQU	
12 12 0 032 137	ILZFR6D11	
12 12 0 032 273	LKR8AP	
12 12 0 034 091	ZKBR7A-HTU	
12 12 0 034 094	R6601-9	
12 12 0 034 097	PLZKBR7B8G	
12 12 0 034 098	PLZKBR7B8G	
12 12 0 034 677	PLZKBR7B8G	
12 12 0 035 531	ILZKBR7B8G	
12 12 0 035 747	PFR7B	
12 12 0 035 915	PLZFR6A-11S	
12 12 0 035 933	PLZKBR7B8G	
12 12 0 037 581	SILZKBR8D8S	
12 12 0 037 607	BKR6EQUP	30
12 12 0 037 608	BKR6EQUP	30
12 12 0 037 663	LZFR6AP11GS	
12 12 0 038 349	ZKBR7A-HTU	
12 12 0 038 507	SIZKBR8A8HS	
12 12 0 039 664	SILZKBR8D8S	
12 12 0 040 551	SILZKGR8B8S	
12 12 0 040 552	SILZKGR8C8S	
12 12 0 041 666	SILZKGR8B8S	
12 12 0 141 871	BKR6EQUP	30
12 12 1 342 836	BKR7EKC	
12 12 1 404 310	PKR7A	
12 12 1 435 955	BKR6EQUP	30
12 12 1 435 956	BKR6EQUP	30
12 12 1 704 399	BKR6EK	20
12 12 2 158 165	PLZKBR7B8G	
12 12 2 158 252	IZFR6H11	
12 12 2 158 253	PLZFR6A-11S	
12 12 7 521 111	PLZFR6A-11S	
12 12 7 521 112	ILZFR6D11	
12 12 7 523 457	BKR6EQU	
12 12 7 526 799	IZFR6H11	
12 12 7 534 226	PLZKBR7B8G	
12 12 7 550 011	ZKBR7A-HTU	
12 12 7 550 011 02	ZKBR7A-HTU	
12 12 7 556 979	BKR7EQUP	
12 12 7 570 106	ILZKBR7B8G	

BMW	→ NGK	V-Line
12 12 7 570 106.02	ILZKBR7B8G	
12 12 7 600 474	LZFR6AP11GS	
12 12 7 600 994	SIZKBR8A8HS	
12 12 7 650 676	BKR7EKC	
12 12 7 650 676.3	BKR7EKC	
12 12 7 653 771	BKR7EKC	
12 12 7 671 301	DCPR8EKC	
12 12 7 671 302	BKR7EKC	
12 12 7 677 560	DCPR8EKC	
12 12 7 681 415	BKR7EKC	
12 12 7 728 634	DCPR8EKC	
12 12 7 830 787	DCPR8EKP	
12 12 7 830 787.3	DCPR8EKP	
12 12 7 835 198	LKR8AP	
12 12 9 061 870	ZFR5F	53
12 12 9 063 428	BKR6EK	20
12 12 9 064 617	BKR6EK	20
12 12 9 064 619	BKR6EK	20
12 12 9 064 656	BKR6EK	20
12 12 9 065 366	BKR6EK	20
12 12 9 069 048	PKR7A	
12 12 9 071 003	BKR6EQUP	30
75 34 2 26A I04	PLZKBR7B8G	
91 47 1 210 043	PFR7B	
CHRYSLER	→ NGK	V-Line
04606 402 AB	LZTR4A-11	
04606 591 AB	ZFR5LP-13G	
04886 204	BP5HS	
04886 205	BP5ES-A	
04886 206	BP6ES	4
04886 207	BP5FS	
04886 208	BP4FS	
04886 210	BP5EFS	
04886 211	TR4	
04886 213	BPR5ES-11	
04886 214	BPR4ES-11	
04886 215	BCPR5ES	32
04886 217	BPR5ES-A	
04886 219	BKR6ES	28
04887 030	ZFR5F-11	40
04887 031	BKR5ES-11	33
04887 032	PFR5J-11	
051 490 50AB	LZFR5CI-11	
680 798 88AB	LZFR5CI-11	
681 438 77AA	LZFR5CI-11	
681 438 77AB	LZFR5CI-11	
S2LZT R4A 11	LZTR4A-11	
SP0 798 88AB	LZFR5CI-11	
SP1 438 77AA	LZFR5CI-11	
SP1 438 77AB	LZFR5CI-11	
SP1 481 83AB	LZFR5CI-11	
SP1 481 83AC	LZFR5CI-11	



CHRYSLER	→ NGK	V-Line
SP 149125 AD	ILZKR7B11GS	
SP 149125 AE	ILZKR7B11GS	
SPL ZFR 5C11	LZFR5CI-11	
DAIHATSU	→ NGK	V-Line
90048-51006-000	B8ES	
90048-51008-000	B7ES	
90048-51015-000	B6ES	
90048-51022-000	B6HS	
90048-51033-000	B5ES	
90048-51034-000	BP6ES	4
90048-51034-010	BP6ES	4
90048-51035-000	BP6EY	
90048-51038-000	B6ES	
90048-51039-000	BPR6EK-A	
90048-51040-000	BPR6EK-A	
90048-51041-000	BPR6EY	
90048-51044-000	BPR5EY	9
90048-51047-010	BP5EY	
90048-51048-000	BPR5EY	9
90048-51049-000	BPR4EY-11	
90048-51050-000	BPR5EY-11	
90048-51053	BP5EY	
90048-51053-000	BP5EY	
90048-51054	BPR5EY	9
90048-51054-000	BPR5EY	9
90048-51055-000	BP6ES	4
90048-51058-000	BE527Y-11	
90048-51059	BPR6EY	
90048-51059-000	BPR6EY	
90048-51062-000	BPR5EY-11	
90048-51063	BPR5EY-11	
90048-51063-000	BPR5EY-11	
90048-51068-000	BPR6EY-11	10
90048-51069-000	BP6EY	
90048-51072-000	BP5ES	8
90048-51073-000	BPR6EK-A	
90048-51074-000	BPR6EK-A	
90048-51077-000	BPR6EKN	
90048-51079-000	BKR7E-11	
90048-51081-000	BPR5EY-11	
90048-51082-000	BPR5EY	9
90048-51084-000	BPR7EKN	
90048-51086-000	BPR6EK-A	
90048-51087-000	BPR6EK-A	
90048-51091-000	BPR5EY-11	
90048-51092-000	BPR6EY-11	10
90048-51093-000	BPR5EY-11	
90048-51093-A	BPR5EY-11	
90048-51095-000	BPR6ES	2
90048-51096-000	BPR6ES	2
90048-51099-000	BKR6E-11	14
90048-51100	BKR6E-11	14

DAIHATSU	→ NGK	V-Line
90048-51100-000	BKR6E-11	14
90048-51101-000	BPR5EY	9
90048-51102-000	BPR6EKN	
90048-51103-000	BPR7EKN	
90048-51104-000	BPR6EKN	
90048-51105-000	BPR7EKN	
90048-51114	BPR5ES	6
90048-51114-000	BPR5ES	6
90048-51117-000	PFR6B-11	
90048-51118-000	PFR6B-11	
90048-51121-000	BPR4EY	
90048-51123	BKR6EY-11	
90048-51123-000	BKR6EY-11	
90048-51125-000	BPR5EJ	
90048-51126	BPR5EJ	
90048-51126-000	BPR5EJ	
90048-51133-000	BCPR6EKD	
90048-51134	BCPR6EKD	
90048-51134-000	BCPR6EKD	
90048-51134-1	BCPR6EKD	
90048-51136-000	BKUR6EK	
90048-51137	BKUR6EK	
90048-51137-000	BKUR6EK	
90048-51143-000	BKUR7EK	
90048-51144	BKUR7EK	
90048-51144-000	BKUR7EK	
90048-51145	BKR4E	
90048-51151-000	BKR6E	28
90048-51152	BKR6E	28
90048-51152-000	BKR6E	28
90048-51154-000	BKR6EKC	26
90048-51155	BKR7EKC	
90048-51155-000	BKR6EKC	26
90048-51156-000	R7433-9	
90048-51158-000	BKR5E-11	33
90048-51158-008	BKR5E-11	33
90048-51159-000	BKUR6EK-9	
90048-51160	BKUR6EK-9	
90048-51160-000	BKUR6EK-9	
90048-51161	BKR7E	
90048-51161-000	BKR7E	
90048-51162	IFR7F-6D	
90048-51163-000	BKR6EYA-11	
90048-51165	BKR5EKC	
90048-51165-000	BKR5EKC	
90048-51166	PFR6G	
90048-51166-000	PFR6G	
90048-51167-000	BKR6EIX-P	
90048-51168	BKUR6ETB-10	
90048-51168-000	BKUR6ETB-10	
90048-51169-000	BKUR6ETB-10	
90048-51172-000	BKR6EIX-11P	



DAIHATSU	→ NGK	V-Line
90048-51173	IFR6J11	
90048-51173-000	IFR6J11	
90048-51175-000	BKR6EKPA	
90048-51185-000	ILFR6T11	
90048-51187	IKR7C	
90048-51196	DCPR7EA-9	
90048-51197	DCPR7EA-9	
90048-51200	IKR7D	
90919-01026-000	BP5EY	
90919-01056-000	BP4EY	
90919-01059-000	BP5EY	
90919-01060-000	BP4EY	
90919-01061-000	BP5EY	
90919-01065-000	BPR4EY	
90919-01085-000	BP4EY-11	
90919-01086-000	BP4EY-11	
90919-01087-000	BPR5EIX-11	
90919-01106-000	BP4EY-11	
90919-01115-000	BPR5EP-11	
90919-01116-000	BPR5EP-11	
90919-01117-000	BE529Y-11	
90919-01118-000	BE529Y-11	
90919-01177-000	BKR5EYA	
90919-01181-000	BKR6EP-8	
90919-01202-000	BKR6EKB-11	
99113-39236-10	AB-6	
99113-39236-200	AB-6	
99123-11236-100	AB-7	
99123-11236-220	AB-7	
99251-30200-100	B-4	
99520-21236-132	B8HS	
99906-850P9-006	BPR6HS	3
99906-850P9-009	BR7ES	
99906-850P9-011	BPR5ES-11	
99906-850P9-012	BPR6ES-11	13
99906-850P9-013	BPR5ES-13	
99906-850P9-015	BPR5EIX-11	
99906-850P9-017	BRE527Y-11	
99906-850P9-018	BRE529Y-11	
99906-910P9-004	BPR5HS	
99906-910P9-005	BPR6HS	3
99906-910P9-006	BR5ES	
99906-910P9-007	BR6ES	
99906-910P9-008	BR7ES	
99906-910P9-009	BR8ES	
99906-910P9-011	BPR5ES-11	
99906-910P9-012	BPR6ES-11	13
99906-910P9-013	BPR5EIX-11	
99906-910P9-015	BPR4EY-11	
99906-910P9-017	BPR6EY-11	10
99906-910P9-020	BPR6E	2
99906-910P9-021	BCPR5E-11	

DAIHATSU	→ NGK	V-Line
99906-910P9-022	BCPR5EY-11	
99906-910P9-023	BCPR6E-11	11
99906-910P9-024	BCPR6EY-11	
99906-910X9-001	BPR5EIX-11	
99906-910X9-002	BPR6EIX-11	
99906-910X9-003	BPR7EIX	
99906-910X9-004	BCPR5EIX-11	
99906-910X9-005	BCPR6EIX-11	
99906-910X9-006	BKR5EIX-11	
99906-910X9-007	BKR6EIX-11	
99906-910X9-008	BPR6HIX	
99906-910X9-009	BPR7HIX	
99906-910X9-010	BR6HIX	
99906-910X9-011	BR7HIX	
99906-910X9-012	BR8EIX	
99906-910X9-013	BR9EIX	
99906-910X9-014	DR8EIX	
99906-910X9-015	DR9EIX	
99906-910X9-018	DCPR7EIX	
99906-910X9-019	ZFR5FIX-11	
99906-910X9-020	ZFR6FIX-11	
99906-910X9-022	CR9EHIX-9	
99906-910X9-023	CR8EIX	
99906-910X9-025	IRIWAY7	
99906-910X9-026	BPR5EIX	
99906-910X9-027	BPR6EIX	
99906-910X9-028	BKR5EIX	
99906-910X9-029	BKR6EIX	
99906-910X9-030	BKR7EIX-11	
99906-910X9-031	BCPR7EDIX	
99906-910X9-032	BKR5EIX-P	
99906-910X9-033	BKR5EIX-11P	
99906-910X9-034	BKR6EIX-P	
99906-910X9-035	BKR6EIX-11P	
99934-00691-100	BPR6EIX	
99934-01691-100	BPR5EIX	
99934-03691-100	BR7EIX	
99934-05691-100	BP5ES-11	
99934-06691-100	BP6ES-11	
99934-07685-100	BP5EY-11	
99934-07691-100	BP5HS	
99934-08685-100	BP6EY-11	
99934-08691-100	BP5ES-13	
99934-09685-100	BP6HS	18
99934-09691-100	BP6HS	18
99934-10691-100	BP4EY	
99934-12685-100	BP5HS	
99934-13685-100	BP6ES-11	
99934-14685-100	BP5ES-13	
NDIK 16	BKR5EIX-11	
NDIK 16 A	BKR5EIX-11	
NDIK 20	BKR6EIX-11	



DAIHATSU	→ NGK	V-Line
NDIK 20 A	BKR6EIX-11	
NDIK 22	IRIWAY7	
NDIK 22 A	IRIWAY7	
NDIK 24 A	IRIWAY8	
NDIK 27 A	IRIWAY9	
NDIQ 16	BCPR5EIX-11	
NDIQ 16 A	BCPR5EIX-11	
NDIQ 20	BCPR6EIX-11	
NDIQ 20 A	BCPR6EIX-11	
NDIQ 22	IRITOP7	
NDIQ 22 A	IRITOP7	
NDIQ 24 A	IRITOP8	
NDIQ 27 A	IRITOP9	
NDIW 16	BPR5EIX-11	
NDIW 16 A	BPR5EIX-11	
NDIW 20	BPR6EIX-11	
NDIW 20 A	BPR6EIX-11	
NDIW 22	BPR7EIX	
NDIW 22 A	BPR7EIX	
NDIXU 22	DCPR7EIX	
NDIXU 22 A	DCPR7EIX	
NDVK 16	BKR5EIX-11P	
NDVK 16 A	BKR5EIX-11P	
NDVK 20	BKR6EIX-11P	
NDVK 20 A	BKR6EIX-11P	
NDVK 22	BKR7EIX-P	
NDVK 22 A	BKR7EIX-P	
NDVQ 16	BCPR5EIX-11P	
NDVQ 16 A	BCPR5EIX-11P	
NDVQ 20	BCPR6EIX-11P	
NDVQ 20 A	BCPR6EIX-11P	
NDVXU 22	DCPR7EIX-P	
NDVXU 22 A	DCPR7EIX-P	
FIAT Group	→ NGK	V-Line
0 00 00 55 24 98 68	IKR9J8	
55 24 98 68	IKR9J8	
15 57 43	PKR9B	
16 83 25	PMR8A	
16 94 83	PMR7A	
19 26 37	PMR8B	
19 45 03	PMR8C-H	
23 92 42	PMR8C-H	
24 66 15	SPMR8A6HDG	
25 47 71	MR8AP8HJS	
31 02 35	SILKAR8C6DS	
31 2A 20 00	ILKR9G8	
31 32 53 225	DCPR8E	
46 14 47 31	DCPR8E	
46 22 92 51	BP6ES	4
46 41 33 860	BKR6EKC	26
46 41 70 10	BKR6E	28
46 44 96 90	BKR6EKPA	

FIAT Group	→ NGK	V-Line
46 46 38 01	BKR6EKC	26
46 47 10 78	BKUR6ETB	
46 47 20 21	BKR6EKC	26
46 47 51 64	BCPR7ET	
46 48 03 07	BKR6EKC	26
46 48 03 09	BKR5EKC	
46 48 03 62	BKR6E	28
46 48 12 73	DCPR8E	
46 48 42 73	DCPR8E	
46 52 15 29	BKR6EKPA	
46 52 15 30	PMR7A	
46 53 19 17	DCPR8EKC	
46 53 19 18	BKR5EZ	36
46 54 84 78	BKR6EZ	38
46 54 95 76	BKR6EKPA	
46 54 95 77	PMR7A	
46 55 09 91	BKUR6ETB	
46 55 09 92	CR7EKC	
46 75 05 45	DCPR8E-N	
46 75 96 88	BP6E	4
46 82 32 99	DCPR7E-N-10	43
50 05 14 91	ILZKR7G7G	
50 05 14 910	ILZKR7G7G	
50 40 82 651	IFR7F-6D	
55 18 26 23	FR5CP	
55 18 88 57	DCPR7E-N-10	43
55 19 07 88	ZKR7A-10	42
55 21 06 85	IKR9J8	
55 21 72 32	ILKAR7D6G	
55 23 23 60	ZKR7AI-8	
00 55 23 39 97	ILKR9G8	
55 24 00 46	LKR7DI-12	
55 24 21 87	ILKR9G8	
55 25 95 65	ZKR7BI-10	
58 94 58 5	BPR7ES	19
58 94 58 6	BKR6E	28
58 94 58 8	BCPR7ES	
58 96 17 7	BKR6EKC	26
58 96 82 4	BKR6EKC	26
58 96 82 41	BKR6EKC	26
59 84 03 6	BPR6ES	2
60 33 02 211	BP7HS	
60 50 45 63	BP6ES	4
60 51 28 48	BCP6ET	
60 51 29 29	B7ES	
60 56 90 86	PGR6A	
60 56 99 57	PFR6B	
60 57 99 03	PFR6B	
60 59 74 90	BCP7ES	
60 59 94 95	PMR7A	
60 80 03 25	BPR7ES	19
60 80 60 24	BUR6ET	1

FIAT Group	→ NGK	V-Line
60 81 06 89	PFR6B	
67 00 50 892	LKAR8AP7JDS	
71 71 16 38	BKR6E	28
71 71 16 39	BPR6ES	2
71 71 16 40	BPR6ES	2
71 71 18 06	BPR6ES	2
71 71 18 08	BKR6E	28
71 73 98 67	ZFR5F-11	40
71 75 02 23	IFR6J11	
75 46 51 9	BKR6E	28
75 54 43 6	BPR7ES	19
75 54 44 2	BP6ES	4
75 54 44 4	BPR6ES	2
75 54 44 5	BP6HS	18
75 65 47 6	BR8ES	
76 86 64 3	BUR6ET	1
77 60 38 1	BPR7ES	19
77 60 38 2	BPR6ES	2
77 60 38 3	BKR6E	28
77 60 38 4	BCPR7ES	
77 69 24 3	BKR6EKC	26
77 72 45 3	BKR6E	28
77 72 51 5	BPR7ES	19
79 10 24 72 04	BPR6EFS	7
7FY SR	BPR7ES	19
7FY SSR	BPR7ES	19
7GB YSR4	BCPR7ET	
7GY SSR	BCPR7ES	
96 02 46 07 80	BKR6EKC	26
96 04 08 24 80	BKR6EKC	26
96 08 86 69 80	BKR6EKC	26
96 08 92 20 80	BKR6EKC	26
96 14 73 86 80	BKR6EKC	26
96 18 49 45 80	BKR6EKC	26
96 18 57 18 80	BKR6EKC	26
96 19 62 45 80	BKR6EKC	26
96 26 575 480	BKR6EKC	26
96 28 00 0280	BKR6EKC	26
96 38 10 57 80	BKR6EKC	26
96 39 81 43 80	BKR6EKC	26
9FY SSR	BPR6ES	2
9GY SSR	BKR6E	28
FORD	→ NGK	V-Line
1032 705	BKR5EKUP	
1077 002	PTR5A-13	25
1120 170	PZFR5D-11	34
1202 935	PLTR6A-10G	
1204 572	PTR6F-13	
1219 309	TR5B-13	45
1255 464	TR5B-13	45
1307 093	PTR6D-13G	
1315 691	ITR6F13	

FORD	→ NGK	V-Line
1362 012	TR5B-13	45
1369 704	TR6AP-13	
1379 739	ILTR5A-13G	
1493 001	TR5B-13	45
1505 812	PLFR6A	
1542 499	ZKR7A-10	42
1685 720	ILZTR6A8G	
1770 305	SILZNR8C7H	
1787 829	TR5B-13	45
1835 546	LZNR7AI-8G	
3539 125	PTR5D-10	31
4331 810	PTR5D-13	
5100 429	ILTR6G8G	
1583 231	ILFR6B	
1680 406	LTR6A-10	
1802 090	ILZNR8A7G	
1M5O-12405-CA	PLTR6A-10G	
1S7J-12405-DA	PTR6F-13	
1S7J-12405-EB	PTR6D-13G	
1S7J-18344-EB	PTR6D-13G	
2249 260	ILTR6R8G	
2350 564	ILTR6S8	
3S4J-12405-AB	ITR6F13	
3S4J-18344-AB	ITR6F13	
4M5G-12405-AA	TR5B-13	45
4M5G-12405-XC	TR5B-13	45
4M5G-12405-XE	TR5B-13	45
5166 347	LTR6A-10	
5425 858	ILTR6R8G	
5M5G-12405-AA	TR6AP-13	
5M5G-18344-AA	TR6AP-13	
6118-61240-5BB	ILTR5A-13G	
6M5J-12405-AA	PLFR6A	
6M8G-12405-BB	ILTR5A-13G	
7G9N-12405-AA	ILFR6B	
95VW-12405-DA	BKR5EKUP	
9A6G-12405-AA	ILTR6G8G	
9A6G-12405-BA	ILTR6H8G	
9A6G-12405-CA	ILTR6H8G	
9S51-12405-AA	ZKR7A-10	42
AYFS-092FE-C	PLTR6A-10G	
BL3E-12405-CA	LTR6AI-9	
BM5G-12405-CA	ILZTR6A8G	
CA6G-12405-AB	LZNR7AI-8G	
CB5E-12405-AA	LTR6DI-8	
CM5E-12405-BA	LTR6BI-9	
CM5G-12405-CE	SILZNR8C7H	
CS6G12405AA	LTR6A-10	
CV6E-12405-AA	ILTR5K13	
DS7G-12405-BA	ILZNR8A7G	
F43E-12405-EB	PTR5D-13	
HL3E12405AA	ILTR6R8G	



FORD	→ NGK	V-Line
HX7G12405BA	ILTR6R8G	
ML3E12405EA	ILTR6S8	
XS4F-12405-DA	PTR5A-13	25
YM21-12405-AA	PZFR5D-11	34
YN2F-12405-A2A	TR5B-13	45
YN2J-12405-AA	TR5B-13	45
GM	→ NGK	V-Line
12 14 046	PFR6T-G	
12 14 060	PFR6D10G	
12 14 065	DILFR7B10G	
12 14 066	IFR7X7G	
12 14 528	ZFR6BP-G	
48 11 581	ILTR5D	
5 958 780	BCPR5EIX	
9 399 866	PFR6H-10	
12 14 000	BKR5EK	23
12 14 011	BKR5EQUPA	
12 14 013	LTR6B-10T	
1 214 114	SILZNR6D9	
12 556 183	PTR5C-13	
12 561 466	PTR5C-13	
12 563 707	PZTR5A-15	
12 565 030	ITR4A15	
12 568 387	ITR4A15	
12 571 535	PTR5C-13	
12 578 277	PZTR5A-15	
12 620 540	ILTR5D	
12 622 561	ILTR6E11	
12 637 197	SILZNR6D9	
12 659 684	SILZNR6D9	
12 787 099	PFR6T-10G	
12 788 884	PLFR6C-10G	
24 504 873	ITR4A15	
25 186 682	ZFR6U-9	
25 197 812	IZFR5R7G	
30 520 467	BCPR6ES-11	11
32 000 330	BCPR7ES-11	
55 182 623	FR5CP	
55 486 272	SILNAR7B7	
55 490 097	ILNAR8B7G	
55 562 534	PFR6T-G	
55 564 215	BKR7ESC-11	
55 564 748	DILFR7B10G	
55 564 763	ZFR6BP-G	
55 565 219	ZFR6V-G	
55 571 391	PFR6D10G	
55 576 026	IFR7X7G	
91 95 109	BKR5EK	23
91 95 868	BKR5EQUPA	
91 99 038	LTR6B-10T	
93 161 199	PFR6G-9	
93 176 801	ZFR5F	53

GM	→ NGK	V-Line
94 535 748	BPR5EY-11	
95 528 735	IZFR5R7G	
96 464 000	DCPR8E	
HONDA	→ NGK	V-Line
12260-RL6-G010	ILZKR7B11GS	
12290-59B003	ILZKAR8H8S	
122905-A2A01	DILKAR7G11GS	
12290-5B0Y01	ILKAR7K11S	
12290-5R0003	DILZKAR7C11S	
12290-P5M-A000	PZFR6F-11	
12290-P73-J001	PFR7G-11	
12290-PCX-0000	PFR7G-11S	
12290-PCX-9999-TA	PFR7G-11S	
12290-PCX-J000	PFR7G-11S	
12290-PFD-J000	IFR6C	
12290-PGE-A01	PZFR6F-11	
12290-PNA-0030	IZFR6K13	
12290-PND-A01	IZFR6K11	
12290-PND-A010-M1	IZFR6K11	
12290-PNE-0030	ZFR6K-11	
12290-PRB-A010-M1	IFR7G-11KS	
12290-R1A-H01	SILZKR7C11S	
12290-R1A-H011-M1	SILZKR7C11S	
12290-R2C-T01	SILZKR7C11DS	
12290-R41-L01	DILZKR7B11GS	
12290-R41-L011	DILZKR7B11GS	
12290-R41-L011M1	DILZKR7B11GS	
12290-R60-U010-M1	IZFR6K11NS	
12290-R71L01	DILZKR7A11G	
12290-R71-L010-M1	DILZKR7A11G	
12290-RB0-J01	DIFR6D13	
12290-RB0-J11	DIFR6D13	
12290-RB0-J110-M1	DIFR6D13	
12290-RB0-JB11	DIFR6D13	
12290-RB1-0030	IZFR6K13	
12290-RB1-0031	IZFR6K13	
12290-RL6-G01	ILZKR7B11GS	
12290-RL6-G010-M1	ILZKR7B11GS	
12290-RMX-0030	ILFR6J-11K	
12290-RMX-0130	ILFR6J-11K	
12290-RSH-0030	IFR6G-11K	
12290-RW0-003	DILFR6J11	
12290-RW0-003	DILFR6J11	
31901-NN2-0030	BR6ES	
31901-NX4-7020-M1	R7376-10	
31901-NX4-9010	R7376-10	
31916-KWB-601	CPR6EA-9S	
3191W-Z0M-5400	BPR4ES	
3191W-Z0M-5500	BPR5ES	6
3191W-Z0M-5600	BPR6ES	2
89819-99010	BPR5ES	6
89839-99010	BPR6ES	2



HONDA	→ NGK	V-Line
98056-57918	CR7HSA-9	
98059-5991F	CR9EHIX-9	
98061-57611	DPR7Z	
98061-57616	DPR7Z	
98069-5697Q	DCPR6E	
98069-5797Q	DCPR7E	
98069-59717	D9EA	
98073-54710	B-4	
98076-55711	BP5HS	
98076-55717	BPR5HS	
98076-55719	BP5HS	
98076-55747	BPR5HS	
98076-56710	B6HS	
98076-56711	B6HS	
98076-56717	BPR6HS	3
98076-56719	BP6HS	18
98076-56719-02	BP6HS	18
98076-56721	BP6HS	18
98076-56729	BPR6HS	3
98076-56740	B6HS	
98076-56741	B6HS	
98076-56747	BPR6HS	3
98076-56756	BPR6HS	3
98076-57710	B7HS	
98076-57711	BP7HS	
98076-57716	BR7HS	
98076-57717	BPR7HS	
98076-57719	BP7HS	
98076-57719-01	BP7HS	
98076-57740	B7HS	
98076-58710	B8HS	
98076-58740	B8HS	
98076-59710	B9HS	
98076-59740	B9HS	
98078-561BW	IZFR6K-11S	
98078-561CW	IZFR6K-11S	
98079-54148	BCPR4ES-11	
98079-5414G	ZFR4F-11	
98079-54817	BPR4ES	
98079-54841	BP4ES	
98079-54846	BPR4ES	
98079-55132	BPR5EY-11	
98079-55140	BCPR5EY-11	
98079-55141	BP5EY-11	
98079-55144	BP5ES-11	
98079-55145	BPR5ES-11	
98079-55146	BPR5EY-11	
98079-55147	BCPR5ES-11	
98079-55148	BCPR5E-11	
98079-55149	BCPR5EY-11	
98079-5514B	BCPR5E-11	
98079-5514E	BKR5E-11	33

HONDA	→ NGK	V-Line
98079-5514E-H0	BKR5E-11	33
98079-5514F	BCPR5EIX-11	
98079-5514G	ZFR5F-11	40
98079-5514G-01	ZFR5F-11	40
98079-5514H	PFR5G-11	
98079-5514J	BKR5E-N-11	
98079-5514N	PZFR5F-11	
98079-5514N-01	PZFR5F-11	
98079-5514P	ZFR5J-11	
98079-5514P-H0	ZFR5J-11	
98079-55155	BPR5E-11	
98079-55158	BCPR5E-11	
98079-5515E	BKR5E-11	33
98079-5515G	ZFR6F-11	
98079-5515H	PFR5G-11	
98079-5515J	BKR5E-N-11	
98079-5515N	PZFR5F-11	
98079-55173	BUR5EB-11	
98079-55174	BUR5EB-11	
98079-55176	BUR5EB-11	
98079-55178	BUR5EB-11	
98079-5517S	PFR5L-11	
98079-5517V	IFR5G-11K	
98079-55183	BUR5EB-11	
98079-55810	B5ES	
98079-55811	BP5ES	8
98079-55816	BR5ES	
98079-55817	BPR5ES	6
98079-55840	B5ES	
98079-55841	BP5ES	8
98079-55841-03	BP5ES	8
98079-55844	BPR5EIX	
98079-55846	BPR5ES	6
98079-55847	BR5ES	
98079-55848	BR5ES	
98079-55849	BR5ES	
98079-55855	BPR5E	6
98079-5585C	BKR5E	35
98079-5585V	ZGR5A	15
98079-55876	BPR5ES	6
98079-55876-H0	BPR5ES	6
98079-5587G	ZFR5F	53
98079-5587V	ZGR5A	15
98079-55941	BP5EY	
98079-55946	BPR5EY	9
98079-55A4N	PZFR5F-13	
98079-55A5N	PZFR5F-13	
98079-56115	BPR6ES-11	13
98079-5611R-00	ZFR6F-11	
98079-56132	BPR6EY-11	10
98079-56140	BKR6E-11	14
98079-56144	BP6ES-11	



HONDA	→ NGK	V-Line
98079-56145	BPR6ES-11	13
98079-56146	BPR6EY-11	10
98079-56147	BCPR6ES-11	11
98079-56148	BCPR6E-11	11
98079-56149	BCPR6EY-11	
98079-5614A	BCPR6EY-N-11	
98079-5614B	BKR6E-11	14
98079-5614E	BKR6E-11	14
98079-5614F	BCPR6EIX-11	
98079-5614G	ZFR6F-11	
98079-5614G-01	ZFR6F-11	
98079-5614H	PFR6G-11	
98079-5614J	BKR6E-N-11	
98079-5614J-01	BKR6E-N-11	
98079-5614N	PZFR6F-11	
98079-5614P	ZFR6J-11	
98079-5614P-00	ZFR6J-11	
98079-56155	BPR6ES-11	13
98079-56158	BCPR6EY-11	
98079-5615E	BKR6E-11	14
98079-5615F	BCPR6EIX-11	
98079-5615G	ZFR6F-11	
98079-5615H	PFR6G-11	
98079-5615J	BKR6E-N-11	
98079-5615N	PZFR6F-11	
98079-56173	BUR6EB-11	
98079-56174	BUR6EB-11	
98079-56175	BP6EY-11	
98079-56179	BUR6EB-11	
98079-5617T	PFR6N-11	
98079-5617V	IFR6G-11K	
98079-56183	BUR6EB-11	
98079-56810	B6ES	
98079-56811	BP6ES	4
98079-56817	BR6ES	
98079-56832	BPR6EY	
98079-56840	B6ES	
98079-56841	BP6ES	4
98079-56844	BPR6EIX	
98079-56846	BPR6ES	2
98079-56847	BR6ES	
98079-56849	BR6ES	
98079-56854	BP6ES	4
98079-56855	BPR6ES	2
98079-5685C	BKR6E	28
98079-56871-H0	BP6ES	4
98079-56876-H0	BPR6ES	2
98079-5687V	BPR6EY	
98079-56941	BP6EY	
98079-56946	BPR6EY	
98079-5695U	IFR6C	
98079-5697U	IFR6C	

HONDA	→ NGK	V-Line
98079-569BE	BKR6E-9S	
98079-569CE	BKR6E-9S	
98079-56A7H	PFR6G-13	
98079-56A7S	PFR6L-13	
98079-57144	BP7ES-11	
98079-57145	BPR7ES-11	
98079-57146	BPR7EY-11	
98079-57147	BCPR7ES-11	
98079-57148	BCPR7E-11	
98079-5714A	BCPR7EY-N-11	
98079-5714B	BCPR7E-11	
98079-5714E	BKR7E-11	
98079-5714F	BKR7EIX-11	
98079-5714G	ZFR7F-11	
98079-5714H	PFR7G-11	
98079-5714J	BKR7E-N-11	
98079-5714P	ZFR7J-11	
98079-57155-01	BPR7ES-11	
98079-57158	BCPR7E-11	
98079-5715E	BKR7E-11	
98079-5715F	BKR7EIX-11	
98079-5715G	ZFR7F-11	
98079-5715H	PFR7G-11	
98079-5715J	BKR7E-N-11	
98079-5715V	IFR7G-11KS	
98079-57171	BPR7EY-11	
98079-57173	BUR7EB-11	
98079-57174	BUR7EB-11	
98079-57176	BR6ES	
98079-57177	BUR7EB-11	
98079-57178	BUR7EB-11	
98079-57179	BPR7EY-11	
98079-5717V	IFR7G-11KS	
98079-57183	BUR7EB-11	
98079-571BH	PFR7G-11S	
98079-571BV	IFR7G-11KS	
98079-571CH	PFR7G-11S	
98079-571CV	IFR7G-11KS	
98079-57614	BR7EIX	
98079-57810	B7ES	
98079-57811	BP7ES	
98079-57811-01	BP7ES	
98079-57816	BR7ES	
98079-57840	B7ES	
98079-57841	BP7ES	
98079-57846	BPR7ES	19
98079-57847	BR7ES	
98079-57848	BR7ES	
98079-57849	BR7ES	
98079-57855	BPR7ES	19
98079-5785C	BKR7E	
98079-5785G	ZFR7F	

HONDA	→ NGK	V-Line
98079-57874	BR7EIX	
98079-57876	BR7ES	
98079-57877	BR7ES	
98079-5787G	ZFR7F	
98079-57941	BP7EY	
98079-57946	BPR7EIX	
98079-5814E	BKR8E-11	
98079-5815E	BKR8E-11	
98079-58644	BR8EIX	
98079-58646	BR8EIX	
98079-58648	B8EG	
98079-58678	B8EG	
98079-58810	B8ES	
98079-58810-01	B8ES	
98079-58816	BR8ES	
98079-58840	B8ES	
98079-58841	BP8ES	
98079-58842	B8ECS	
98079-58846	BR8ES	
98079-58847	BPR8ES	
98079-58857	BR8ES	
98079-58870	B8ES	
98079-58872	B8ECS	
98079-58876	BR8ES	
98079-59644	BR9EIX	
98079-59646	BR9EIX	
98079-59810	B9ES	
98079-59811	B9ES	
98079-59840	B9ES	
98079-59870	B9ES	
98079-60616	BR10EIX	
98079-60646	BR10EIX	
98079-60676	BR10EIX	
9807B-5515W	IZFR5K11	
9807B-5517W	IZFR5K11	
9807B-5615P	ZFR6K-11	
9807B-5615W	IZFR6K11	
9807B-5617P	ZFR6K-11	
9807B-5617P-00	ZFR6K-11	
9807B-5617W	IZFR6K11	
9807B-561BW	IZFR6K-11S	
9807B-56A5W	IZFR6K13	
9807B-56A7W	IZFR6K13	
98179-56841	BP6ES	4
9861-5515J	ZFR5FIX-11	
9861-5515K	BKR5EIX-11	
9861-5615J	ZFR6FIX-11	
9861-5615K	BKR6EIX-11	
9861-5615Q	BCPR6EIX-11	
9868-5615K	BKR6EIX-11	
9879-5518J	ZFR5FIX-11P	
9879-5518K	BKR5EIX-11P	

HONDA	→ NGK	V-Line
9879-5518Q	BCPR5EIX-11P	
9879-5618J	ZFR6FIX-11P	
9879-5618K	BKR6EIX-11P	
9879-5618Q	BCPR6EIX-11P	
9879-5718K	BKR7EIX-P	
9880-5518J	ZFR5FIX-11P	
9880-5518K	BKR5EIX-11P	
9880-5518Q	BCPR5EIX-11P	
9880-5618J	ZFR6FIX-11P	
9880-5618K	BKR6EIX-11P	
9880-5618Q	BCPR6EIX-11P	
9880-5718K	BKR7EIX-P	
9881-5515K	BKR5EIX-11P	
9881-5615J	ZFR6FIX-11P	
9881-5615K	BKR6EIX-11P	
9888-5618K	BKR6EIX-11P	
H9861-5515J	ZFR5FIX-11	
H9861-5515K	BKR5EIX-11	
H9861-5615J	ZFR6FIX-11	
H9861-5615K	BKR6EIX-11	
H9861-5615Q	BCPR6EIX-11	
H9868-5615K	BKR6EIX-11	
H9879-5518J	ZFR5FIX-11P	
H9879-5518K	BKR5EIX-11P	
H9879-5518Q	BCPR5EIX-11P	
H9879-5618J	ZFR6FIX-11P	
H9879-5618K	BKR6EIX-11P	
H9879-5618Q	BCPR6EIX-11P	
H9879-5718K	BKR7EIX-P	
H9880-5518J	ZFR5FIX-11P	
H9880-5518K	BKR5EIX-11P	
H9880-5518Q	BCPR5EIX-11P	
H9880-5618J	ZFR6FIX-11P	
H9880-5618K	BKR6EIX-11P	
H9880-5618Q	BCPR6EIX-11P	
H9880-5718K	BKR7EIX-P	
H9881-5515K	BKR5EIX-11P	
H9881-5615J	ZFR6FIX-11P	
H9881-5615K	BKR6EIX-11P	
H9888-5618K	BKR6EIX-11P	
HYUNDAI/KIA	→ NGK	V-Line
00259-18110	BP6ES	4
08914-18110	BPR5ES	6
09482-00538	IFR5G11	
0F287-18110	ZFR5F-11	40
0K01A-18110	BKR5E	35
0K01C-18110	BKR6E-11	14
0K23A-18110	BKR5E-11	33
0K2A1-18110	BPR5EY	9
0K2AA-18110	BKR6E	28
0K558-18110	PFR6N-11	
18811-08051	BPR5ES	6

HYUNDAI/KIA	→ NGK	V-Line
18811-08061	BPR6ES	2
18811-11051	BPR5ES-11	
18811-11061	BPR6ES-11	13
18814-08051	BKR5ES	35
18814-08061	BKR6ES	28
18814-08062	BKR6ES	28
18814-11051	BKR5ES-11	33
18814-11061	BKR6ES-11	14
18814-11062	BKR6ES-11	14
18814-25000	IFR5E11	
18817-11051	PFR5N-11	
18818-11051	PGR5C-11	
18822-08091	BP6ES-11	
18823-11091	BKR5ES-11	33
18827-09080	PLKR7A	
18829-08050	ZFR5F	53
18829-11050	ZFR5F-11	40
18838-11051	IZFR5B	
18840-11051	ILFR5B11	
18841-11051	LFR5A-11	
18842-08061	PLFR6A	
18843-10062	LKR6D-10E	
18844-10060	SILKR6C10E	
18846-10060	SILZKR6B10E	
18846-10061	SILZKR6B10E	
18846-11070	SILZKR7B11	
18847-11160	DILKR6A11	
18851-11060	DILKR6A11	
18854-10080	LZKR6B-10E	49
18855-10060	LZKR6B-10E	49
18858-10090	LZKR6B-10E	49
27400-18110	BKR6E	28
27410-23700	IFR5G11	
AA101-18110	BP5EY	
AA13A-18110AS	BP6EY	
KK150-18110	BP5ES-11	
PS100-4	BP6ES-11	
PS100-8	BKR5ES-11	33
PS101-7	ZFR5F-11	40
PS102-5	SILZKR7B11	
S18829-11050	ZFR5F-11	40
S18855-10060	LZKR6B-10E	49
ISUZU	→ NGK	V-Line
5-8138-0001-0	BPR5ES	6
5-8138-0003-0	BPR5EIX	
5-8138-0004-0	BPR6EIX	
5-8138-0005-0	BP5ES	8
5-8138-0006-0	BP6ES	4
5-8138-0007-0	BP5EY	
5-8138-0008-0	BP6EY	
5-8138-0012-0	BP5EY	
5-8138-0013-0	BP6EY	

ISUZU	→ NGK	V-Line
5-8600-3122-0	ZFR5F-11	40
5-8600-3124-0	ZFR6F-11	
5-8600-7635-0	BKR5E-11	33
5-8600-7636-0	ZFR5J-11	
5-8600-7639-0	ZFR6J-11	
5-8600-7642-0	ZFR7J-11	
5-8601-3957-0	PZFR5F-13	
5-8610-3379-0	BPR4ES-11	
5-8610-3380-0	BPR5ES-11	
5-8610-3381-0	BPR6ES-11	13
5-8610-3382-0	BPR7ES-11	
5-8610-3385-0	PFR5B-11	
5-8610-3386-0	PFR6B-11	
5-8610-3387-0	PFR7B-11	
5-8610-3389-0	PGR5A-11	
5-8610-3390-0	PGR6A-11	
5-8612-1749-0	BKR5ES-11	33
5-8612-1750-0	BKR6ES-11	14
5-8612-3951-0	BKR5E-11	33
5-8612-3952-0	BKR6E-11	14
5-8612-3953-0	BKR7E-11	
8-9412-0560-0	BPR5ES-11	
8-9412-0561-0	BPR5EY-11	
8-9412-0562-0	BPR6EY-11	10
8-9416-0627-0	BPR6EY	
8-9421-7232-0	BPR6ES-11	13
8-9421-9943-0	BPR6ES	2
8-9423-5966-0	BP5ES-11	
8-9423-7203-0	BP5EY-11	
8-9424-1059-0	BP6ES-11	
8-9425-2270-0	BP6EY-11	
8-9432-8372-0	BKR6E-11	14
8-9432-8373-0	BKR7E-11	
8-9432-8374-0	BKR6E-11	14
8-9432-8375-0	BKR7E-11	
8-9701-2928-0	BKR6E	28
8-9701-2930-0	BKR6E	28
8-9701-2931-0	BKR7E	
8-9711-1376-0	PFR5B-11	
8-9717-0268-0	BKR5EIX-11	
9-8251-3103-0	BP6ES	4
9-8251-3105-0	B6ES	
9-8251-3106-0	BP5ES	8
9-8251-3107-0	B5ES	
9-8251-3113-0	B7ES	
IVECO	→ NGK	V-Line
50 40 82 651	IFR7F-6D	
5 801 655 585	IFER7B4D	
88 03 24 15	IFR7F-6D	
88 03 34 33	IGR7E-3D	
JAGUAR	→ NGK	V-Line
7R83-12405-AA	TR6AP-13E	



JAGUAR	→ NGK	V-Line
8W-12405-AAA	ILKAR7C10	
8W93-12405-ABB	ILKAR7C10	
AJ 84575	IFR5N10	
AJ 812146	ILKAR7C10	
AJ 812988	SILZKAR7E8S	
C2A 1535	IFR5N10	
C2P 23089	ILKAR7C10	
C2S 46895	TR6AP-13E	
EAC 8554	BR7EFS	
EBC 004021	BR7EF	
EBC 4021	BR7EF	
LR 019 484	ILKAR7C10	
NCA 3850 DA / 2	BKR6EIX-11	
NCA 3850 FA / 2	PFR6G-13E	
NCA 3850 HA / 2	PFR6G-13E	
LAND ROVER	→ NGK	V-Line
4550 157	IFR5N10	
LR 005 483	ILFR6B	
LR 019 484	ILKAR7C10	
LR 025605	ILTR6G8G	
LR 032 080	ILKAR7C10	
LOTUS	→ NGK	V-Line
A 100 E 6277 S	BKR6E	28
A 910 E 7009 F	BPR6EKN	
MAN	→ NGK	V-Line
88 032 415	IFR7F-6D	
88 033 433	IGR7E-3D	
MAZDA	→ NGK	V-Line
0000-18-1690	BPR6ES	2
0000-18-3648	BR7ET	
0000-18-3649	BR8ET	
0000-18-8914	BPR5ES	6
0000-18-B601	BPR5ES-11	
0000-18-BP01	BKR5E-11	33
0000-18-BP03	BKR6E-11	14
0000-18-BP47	BKR5E	35
0000-18-F201	ZFR6A-11	
0000-18-F203	ZFR5A-11	
0000-18-F285	ZFR6F-11	
0000-18-F287	ZFR5F-11	40
0000-18-JE41	BKR5EIX-11	
0000-18-KJ11	PZFR6F	
0000-18-KJ13	PZFR5F	
0000-18-L3Y1	ILTR6A-13G	
0000-18-L3Y2	ILTR5A-13G	
0000-18-L3Y3	ILTR6A-8G	
0000-18-N201	BR8EQ-14	
0000-18-N203	BR9EQ-14	
0000-18-N328	BUR8EQ	
0000-18-N329	BUR6EQ	
0000-18-N342	BUR9EQ	
0000-18-N343	BUR7EQ	

MAZDA	→ NGK	V-Line
0000-18-N3A1	BUR9EQP	
0000-18-N3A2	BUR7EQP	
0000-18-N3A3	BUR8EQP	
0000-18-N3Y1	RE9B-T	
0000-18-N3Y2L	RE7C-L	
0000-18-N3Y8	RE7C-L	
0190-18-110	B6HS	
0222-18-110	BP6EY	
0259-18-110	BP6ES	4
0370-18-110	BPR6EIX	
0371-18-110	BPR5EIX	
0376-18-110	BPR7EIX	
0418-18-110A	B7ES	
0419-18-110	B7ES	
0420-18-110	B8ES	
0512-18-110	B6ES	
0660-18-110	BP5ES	8
0745-18-110	BP7ES	
0802-18-600	B7EM	
0866-18-600	B7EM	
1001-77-550	BP4EY	
1002-77-550	BP5EY	
1003-77-550	BP6EY	
1409-18-110	BP5ES-13	
1410-18-110	BP5ES-13	
1482-18-600A	BR8EQ	
1483-18-600	BR8EQ	
1534-18-110	BP5EY	
1690-18-110	BPR6ES	2
1A01-18-110	PGR5A	
1A02-18-110	KR7AI	
1A03-18-110	IKR7A	
1A04-18-110	DCPR6E	
1A06-18-110	DCPR8E	
1A08-18-110	ZGR5A	15
1A10-18-110	GR5AI-10	
1A50-18-110	BKR6E	28
1A53-18-110	BKR6E-11	14
1A61-18-110	DCPR7EIX	
1N00-18-110	BKR4E-11	
1N04-18-110	BKR5EY-11	
1N06-18-110	BKR6EY-11	
1N07-18-110	PFR4G-11	
1N08-18-110	PFR5G-11	
1N09-18-110	PFR6G-11	
1N11-18-110	FR7AI-D	
1N15-18-110	LFR5A-11	
1N19-18-110	LZKAR6AP-11	
1N21-18-110	LFR4AP-11	
1N22-18-110	LFR5AP-11	
1UD0-18-110	BPR5EIX-11	
1UD1-18-110	BPR6EIX-11	



MAZDA	→ NGK	V-Line
1UD2-18-110	BPR7EIX	
1UD3-18-110	BKR5EIX-11	
1UD4-18-110	BKR6EIX-11	
1UD6-18-110	BCPR5EIX-11	
1UD7-18-110	BCPR6EIX-11	
1UD9-18-110	DCPR7EIX	
1UN0-18-110	BPR5EIX	
1UN1-18-110	BPR6EIX	
1UN2-18-110	BPR7EIX	
1UN3-18-110	BPR5EIX-11	
1UN4-18-110	BPR6EIX-11	
1UN6-18-110	BKR5EIX	
1UN7-18-110	BKR6EIX	
1UN9-18-110	BKR5EIX-11	
1UNA-18-110	BKR6EIX-11	
1UNC-18-110	BCPR5EIX-11	
1UND-18-110	BCPR6EIX-11	
1UNF-18-110	DCPR7EIX	
1UNG-18-110	ZFR5FIX-11	
1UNH-18-110	ZFR6FIX-11	
1UT3-18-110	BKR5EIX-11P	
1UT4-18-110	BKR6EIX-11P	
1UT6-18-110	BCPR5EIX-11P	
1UT7-18-110	BCPR6EIX-11P	
1UT9-18-110	DCPR7EIX-P	
1UX6-18-110	BKR5EIX-P	
1UX7-18-110	BKR6EIX-P	
1UX9-18-110	BKR5EIX-11P	
1UXA-18-110	BKR6EIX-11P	
1UXC-18-110	BCPR5EIX-11P	
1UXD-18-110	BCPR6EIX-11P	
1UXF-18-110	DCPR7EIX-P	
1UXG-18-110	ZFR5FIX-11P	
1UXH-18-110	ZFR6FIX-11P	
1UXJ-18-110	BPR5EIX-13P	
1Y00-18-110	BPR5ES	6
1Y01-18-110	BPR6ES	2
1Y03-18-110	BPR5ES-11	
1Y06-18-110	BKR5E	35
1Y07-18-110	BKR6E	28
1Y09-18-110	BKR5E-11	33
1Y0A-18-110	BKR6E-11	14
1Y0B-18-110	BKR7E-11	
1Y0F-18-110	DCPR7E	
1Y0G-18-110	ZFR5F-11	40
1Y0H-18-110	ZFR6F-11	
1Y0K-18-110	BPR5ES-13	
1Y0L-18-110	BRE527Y-11	
1YR7-18-110	BKR6EIX-P	
1YR9-18-110	BKR5EIX-11P	
1YRA-18-110	BKR6EIX-11P	
1YRF-18-110	DCPR7EIX-P	

MAZDA	→ NGK	V-Line
1YRG-18-110	ZFR5FIX-11P	
1YRH-18-110	ZFR6FIX-11P	
2182-18-600	B7EM	
2328-18-600	B7EM	
3648-18-600	BR7ET	
3649-18-600	BR8ET	
3710-18-110	BPR6EIX-11	
3743-18-600	BR7ET	
3744-18-600	BR8ET	
3953-18-110	BPR5EY	9
3954-18-110	BPR6EY	
4075-18-110	BP4ES	
4095-18-110	BP4EY	
4096-18-110A	BPR4ES-13	
418-18-110	B7ES	
6M8G-12-405BB	ILTR5A-13G	
8042-18-110	BPR6EIX-11	
8248-18-600	BR8ET	
8344-18-600	BR9ET	
8914-18-110	BPR5ES	6
A501-18-110	BP6E	4
A502-18-110	BP6ES	4
AY02-18-110	DCP7E	
AY01-18-110	DCP7E	
AZ08-18-110	BPR5E	6
AZ09-18-110	BPR5E	6
AZ28-18-110	DCPR7EIX	
AZ29-18-110	DCPR7EIX	
B601-18-110	BPR5ES-11	
B602-18-110	BPR5EY-11	
B64N-18-110	BRE527Y-11	
B64P-18-110	BRE527Y-11	
B660-18-110	BKR6E-11	14
B667-18-110	BKR6E-11	14
B672-18-110	BPR5ES	6
B695-18-110	BCPR6E	12
B696-18-110	BCPR6E	12
B6B3-18-110	BCPR5E-11	
B6B4-18-110	BCPR5E-11	
BBYV-18-110	R7436-10	
BBYV-18-11Z	R7436-9	
BP01-18-110	BKR5E-11	33
BP02-18-110	BKR5E-11	33
BP03-18-110	BKR6E-11	14
BP04-18-110	BKR6E-11	14
BP05-18-110	BKR7E-11	
BP06-18-110	BKR7E-11	
BP07-18-110	BKR6ES-11	14
BP09-18-110	BKR6ES-11	14
BP47-18-110	BKR5E	35
BP47-18-110P00	BKR5E	35
BP48-18-110	BKR5E	35

MAZDA	→ NGK	V-Line
BP49-18-110	BKR6E	28
BP50-18-110	BKR6E	28
BP51-18-110	BKR7E	
BPY1-18-110	BKR5E-11	33
BPY3-18-110	BKR6E-11	14
E356-18-110	BE527Y-11	
E357-18-110	BE527Y-11	
F201-18-110	ZFR6A-11	
F202-18-110A	ZFR6A-11	
F203-18-110	ZFR5A-11	
F204-18-110	ZFR5A-11	
F205-18-110	ZFR7F-11	
F210-18-110	BCPR5E	32
F211-18-110	BCPR5E	32
F220-18-110	BCPR6E-11	11
F221-18-110	BCPR6EY-11	
F261-18-110	ZFR6F-11	
F285-18-110	ZFR6F-11	
F286-18-110	ZFR6J-11	
F287-18-110	ZFR5F-11	40
F288-18-110	ZFR5J-11	
F289-18-110	ZFR7F-11	
F293-18-110	ZFR5F-11	40
F2C5-18-110	ZFR6F-11	
F2C7-18-110	ZFR6F-11	
F806-18-110	BPR4ES-13	
F8B1-18-110	ZFR6A-11	
F8B2-18-110A	ZFR6A-11	
F8B3-18-110	ZFR5F-11	40
F8B5-18-110	ZFR7F-11	
F8B7-18-110	ZFR4F-11	
F8L6-18-110	ZFR4F-11	
F8L7-18-110	ZFR4F-11	
F8L8-18-110	BPR4ES-13	
F8L9-18-110	BPR4ES-13	
FE3N-18-110	BCPR7E-11	
FE6E-18-110	BCPR7E-11	
FE6F-18-110	BCPR7E-11	
FE79-18-110	BPR6ES-11	13
FE82-18-110	BPR6EY-11	10
FEDK-18-110	BPR5ES-13	
FEDM-18-110	BPR5ES-13	
FEEG-18-110	BPR6EIX-11	
FEEH-18-110	BPR6EIX-11	
FEFB-18-110	BPR6ES-11	13
JE03-18-110	BCPR7E	
JE26-18-110	BCPR5EIX-11	
JE27-18-110	BCPR6EIX-11	
JE28-18-110	BCPR5EIX-11	
JE41-18-110	BKR5EIX-11	
JE42-18-110	BKR5EIX-11	
JE43-18-110	BKR6EIX-11	

MAZDA	→ NGK	V-Line
JE44-18-110	BKR6EIX-11	
JE45-18-110	BKR7EIX-11	
JE46-18-110	BKR7EIX-11	
JF03-18-110	BCPR5E-11	
JF04-18-110	BCPR5E-11	
KJ11-18-110	PZFR6F	
KJ12-18-110	PZFR6F	
KJ13-18-110	PZFR5F	
KJ14-18-110	PZFR5F	
L303-18-110	TR5AI-13	
L341-18-110	ITR6F13	
L3BD-18-110	SILTR6A7G	
L3G2-18-110	ILTR6A-13G	
L3K9-18-110	ILTR6A-8G	
L3K9-18-110A	ILTR6A-8G	
L3Y1-18-110	ILTR6A-13G	
L3Y2-18-110	ILTR5A-13G	
L3Y3-18-110	ILTR6A-8G	
L3Y4-18-110	ITR6F13	
L3YD-18-110	SILTR6A7G	
L813-18-110	ITR6F13	
L814-18-110	BPR6EF-13	
L845-18-110	TR5AI-13	
LFG1-18-110	ILTR5A-13G	
LFY1-18-110	TR5B-13	45
LFY3-18-110	BPR5EFS-13	
N201-18-600	BR8EQ-14	
N202-18-600	BR8EQ-14	
N203-18-600	BR9EQ-14	
N212-18-600	BR7EQ-14	
N212-18-600A	BR7EQ-14	
N218-18-600	BR8EQ-14	
N225-18-600A	BUR9EQ	
N236-18-600	BUR9EQ	
N238-18-600	BUR8EQ	
N245-18-600	BUR7EQ	
N246-18-600	BR9EQ-14	
N253-18-600	BR9EQ-14	
N322-18-110	BR10ET	
N328-18-110	BUR8EQ	
N329-18-110	BUR6EQ	
N331-18-110	BUR7EQ	
N333-18-110	BUR9EQ	
N335-18-110	SD9A	
N338-18-110	BUR9EQ	
N339-18-110	BUR7EQ	
N340-18-110	BUR9EQ	
N341-18-110	BUR7EQ	
N342-18-110	BUR9EQ	
N343-18-110	BUR7EQ	
N3A1-18-110	BUR9EQP	
N3A2-18-110	BUR7EQP	



MAZDA	→ NGK	V-Line
N3A3-18-110	BUR8EQP	
N3H1-18-110C	RE9B-T	
N3H1-18-110D	RE9B-T	
N3H2-18-110C	RE7C-L	
N3H5-18-110	RE7C-L	
N3H5-18-110A	RE7C-L	
N3H8-18-110A	RE9B-T	
N3H8-18-110B	RE9B-T	
N3H9-18-110A	RE8C-L	
N3J1-18-110	RE8C-L	
N3J1-18-110A	RE8C-L	
N3M1-18-1BXA	RE7C-L	
N3M1-18-1BXB	RE7C-L	
N3Y1-18-110	RE9B-T	
N3Y1-18-110A	RE9B-T	
N3Y1-18-110A9U	RE9B-T	
N3Y1-18-S30	RE7C-L	
N3Y1-18-S30	RE9B-T	
N3Y1-18-S30L	RE7C-L	
N3Y1-18-S30T	RE9B-T	
N3Y2-18-110	RE7C-L	
N3Y2-18-110L	RE7C-L	
N3Y2-18-S30	RE8C-L	
N3Y2-18-S30	RE9B-T	
N3Y2-18-S30L	RE8C-L	
N3Y2-18-S30T	RE9B-T	
N3Y3-18-S30	RE7C-L	
N3Y3-18-S30	RE9B-T	
N3Y4-18-110	RE9B-T	
N3Y4-18-110A	RE9B-T	
N3Y4-18-S30	RE8C-L	
N3Y4-18-S30	RE9B-T	
N3Y5-18-110	RE8C-L	
N3Y5-18-110L	RE8C-L	
N3Y6-18-110	RE7C-L	
N3Y6-18-110L	RE7C-L	
N3Y8-18-110	RE7C-L	
N3Y8-18-110A	RE7C-L	
N3Y8-18-110A9U	RE7C-L	
N3Z1-18-110	RE8C-L	
N3Z1-18-110A	RE8C-L	
N3Z2-18-110	RE7C-L	
N3Z2-18-110A	RE7C-L	
N3Z4-18-110	RE7C-L	
N3Z5-18-110	RE8C-L	
N3ZZ2-18-110A	RE7C-L	
PBP01-18-110AA	BKR5E-11	33
PE5R-18-110	ILKAR7L11	
PE5S-18-110	ILKAR7L11	
TF50-18-110	BKR6EIX	
Z601-18-110	BKR5EIX-11P	
ZJY6-18-110	IFR5E13	

MAZDA	→ NGK	V-Line
ZR03-18-110	R6725-115	
ZZS1-18-110	DCPR7E	
ZZS2-18-110	DCPR7E	
ZZS3-18-110	BPR5EY	9
ZZS4-18-110	BPR5EY	9
ZZSI-18-110	DCPR7E	
MERCEDES	→ NGK	V-Line
1822 A036	LKR7B-9	
004 159 76 03	SILZKFR8D7G	
A 002 159 18 03	BP7ES	
A 002 159 22 03	BP5ES	8
A 002 159 24 03	BP6ES	4
A 002 159 27 03	BP7ES	
A 002 159 28 03	BP6ES	4
A 002 159 29 03	BP5ES	8
A 002 159 31 03	BP5ES	8
A 002 159 41 03	BP6ES	4
A 002 159 42 03	BP6ES	4
A 002 159 48 03	BP5ES	8
A 002 159 49 03	BP6EFS	5
A 002 159 56 03	BP6EFS	5
A 002 159 57 03	BP5EFS	
A 002 159 58 03	BP5EFS	
A 002 159 64 03	BP7EFS	
A 002 159 65 03	BP7EFS	
A 002 159 68 03	BP6EFS	5
A 002 159 69 03	BP6EFS	5
A 002 159 76 03	BP5EFS	
A 002 159 77 03	BCP5ES	16
A 003 159 04 03	BP5EFS	
A 003 159 05 03	BP5EFS	
A 003 159 06 03	BP6EFS	5
A 003 159 07 03	BP6EFS	5
A 003 159 08 03	BP7EFS	
A 003 159 10 03	BP5ESZ	
A 003 159 11 03	BP5ESZ	
A 003 159 12 03	BP6ESZ	
A 003 159 13 03	BP6ESZ	
A 003 159 14 03	BP7ES	
A 003 159 16 03	BCP6ES	17
A 003 159 30 03	BCP5ES	16
A 003 159 31 03	BCP6ES	17
A 003 159 33 03	BP7EFS	
A 003 159 34 03	BP6EFS	5
A 003 159 35 03	BP6EFS	5
A 003 159 36 03	BP5EFS	
A 003 159 37 03	BCP5ES	16
A 003 159 40 03	BP5EFS	
A 003 159 41 03	BP5EFS	
A 003 159 42 03	BCP5ES	16
A 003 159 45 03	BP6ESZ	
A 003 159 46 03	BP5ESZ	



MERCEDES	→ NGK	V-Line
A 003 159 47 03	BP5ESZ	
A 003 159 56 03	BP7ES	
A 003 159 57 03	BP6ESZ	
A 003 159 75 03	BKUR5ET	29
A 003 159 76 03	BKUR5ET	29
A 003 159 78 03	BKR6ES	28
A 003 159 81 03	PFR5R-11	
A 003 159 90 03	BKUR5ET	29
A 003 159 91 03	BKR5EKUP	
A 003 159 92 03	BKR6EKE	
A 003 159 94 03	PFR5R-11	
A 003 159 96 03	IFR5D10	
A 003 159 96 03 26	IFR5D10	
A 003 159 97 03	IFR6D10	
A 003 159 97 03 26	IFR6D10	
A 004 159 13 03	ILFR6A	
A 004 159 14 03	IFR6Q-G	
A 004 159 15 03	LKR8A	
A 004 159 18 03	PLKR7A	
A 004 159 19 03	PFR5R-11	
A 004 159 25 03	SILZKR7A-S	
A 004 159 25 63	SILZKR7A-S	
A 004 159 30 03	BKR6EZB	
A 004 159 34 03	PLKR6A	
A 004 159 36 03	BKR6EZB	
A 004 159 39 03	ILZKAR7A10	
A 004 159 44 03	PLKR7B8E	
A 004 159 45 03	ILFR6A	
A 004 159 49 03	PLKR7A	
A 004 159 50 03	PFR5R-11	
A 004 159 58 03	PLKR7B8E	
A 004 159 65 03	SILZKFR8D7S	
A 004 159 68 03	SILZKFR8D7S	
A 004 159 70 03	SILZKFR8E7S	
A 004 159 72 03	SILZKFR8D7S	
A 004 159 75 03	SILZKFR8D7S	
A 004 159 76 03	SILZKFR8D7G	
A 004 159 79 03	SILZKFR8E7S	
A 122 159 00 03	ILZFR6C-K	
A 132 159 00 03	LKR7B-9	
A 270 159 07 00	SILZKFR8E7S	
A 376 159 72 03	T7204A	
A 476 159 72 03	T7016A	
MN 195 922	ILZFR6C-11K	
QO 003 085 V005 000 000	BKR6EKE	
QO 012 468 V001 00 0000	LKR8A	
QO 012 468 V002 00 0000	LKR8A	
MITSUBISHI	→ NGK	V-Line
1822 A002	IFR6B-K	
1822 A005	ILZFR6C-K	
1822 A011	ILKR7B8	
1822 A021	ILKR8E6	

MITSUBISHI	→ NGK	V-Line
1822 A022	ILFR7H	
1822 A030	FR5EI	
1822 A 067	DILKR7C11	
1822 A068	DIFR5C11	
1822 A069	DIFR6C11	
1822 A 071	DILFR6A11	
1822 A075	LZFR6BI-11	
1822 A079	DILKR8B6	
1822 A085	DILFR5A11	
1822 A086	LZFR5BI-11	
1822 A088	DILKR6D11G	
1822A154	DIFR5E11	
1822-A154	DIFR5E11	
801 001	B-4	
801 033	B7HS	
MD 313 442	PFR5G-11	
MD 313 443	PFR6G-11	
MD 314 766	BKR7EKC-N	
MD 319 517	PFR6G	
MD 320 543	BKR7EKC-N-11	
MD 320 572	BKR5E	35
MD 321 150	BKR6EKC-N-11	
MD 322 771	PFR6B-11	
MD 331 057	ZFR5F-11	40
MD 336 367	IZFR6B	
MD 338 492	BPR4ES	
MD 338 991	PGR7A	
MD 342 386	PZFR5F-11	
MD 343 277	PGR6A	
MD 348 296	PZFR5B	
MD 351 467	PZFR5C	
MD 355 067	BKR6EKUC	
MD 357 531	PFR6J	
MD 358 200	ZFR6F-11	
MD 358 201	ZFR6F-11	
MD 358 202	ZFR6F-11	
MD 360 019	IZFR6B	
MD 360 383	IZFR5B	
MD 361 067	IFR5E11	
MD 362 097	ZFR5F-11	40
MD 362 098	ZFR5F-11	40
MD 362 902	BKR5EKUC	
MD 365 108	BPR5EKU	
MD 366 819	IZFR5C	
MD 371 434	IGR7A	
MD 371 435	IGR7A	
MD 372 421	BKR5EKUD	
MD 372 422	BKR6EKUD	
MD 372 553	IFR5E11	
MD 372 588	IFR6E11	
MD 373 645	IFR6E11	
MD 374 841	IGR7A-G	

mitsubishi	→ NGK	V-Line
MD 375 642	BKR5ETUA	
MD 378 582	IFR6B	
MN 119 256	ILZFR5B	
MN 119 487	IFR6S	
MN 119 500	IGR6A11	
MN 122 257	BKR6EIX-P	
MN 128 362	LFR6C-11	48
MN 158 596	LZFR6AI	
MN 163 235	FR5EI	
MN 163 236	FR6EI	
MN 163 807	FR6EI	
MN 176 628	ILZFR6C-11K	
MN 182 2A0 02	IFR6B-K	
MN 195 922	ILZFR6C-11K	
MS 851 022	BP5ES	8
MS 851 023	BP6ES	4
MS 851 024	BP7ES	
MS 851 027	BP5ES-11	
MS 851 028	BP6ES-11	
MS 851 029	BP7ES-11	
MS 851 097	BP5EY	
MS 851 101	BP4EY	
MS 851 102	BP5EY	
MS 851 104	BP6EY	
MS 851 106	BP4EY-11	
MS 851 107	BP5EY-11	
MS 851 108	BP6EY-11	
MS 851 111	B-4	
MS 851 113	B6S	
MS 851 126	BPR6E	2
MS 851 132	B5HS	
MS 851 133	B6HS	
MS 851 134	B7HS	
MS 851 162	B5ES	
MS 851 163	B6ES	
MS 851 164	B7ES	
MS 851 165	B8ES	
MS 851 174	BR7ES	
MS 851 181	BP4ES	
MS 851 182	BP5ES	8
MS 851 182 A	BP5ES	8
MS 851 183	BP6ES	4
MS 851 184	BP7ES	
MS 851 187	BP5ES-11	
MS 851 188	BP6ES-11	
MS 851 189	BP7ES-11	
MS 851 192	BP6ES	4
MS 851 207	BP5ES-11	
MS 851 208	BP6ES-11	
MS 851 212	BP5ES	8
MS 851 213	BP6ES	4
MS 851 215	BP7ES	

mitsubishi	→ NGK	V-Line
MS 851 217	BPR5ES	6
MS 851 218	BPR6ES	2
MS 851 219	BPR7ES	19
MS 851 227	BPR5ES-11	
MS 851 228	BPR6ES-11	13
MS 851 229	BPR7ES-11	
MS 851 230	BPR4ES-11	
MS 851 232	BPR5ES	6
MS 851 233	BPR6ES	2
MS 851 234	BPR7ES	19
MS 851 235	BPR5ES	6
MS 851 236	BPR6ES	2
MS 851 237	BPR5ES-11	
MS 851 238	BPR6ES-11	13
MS 851 239	BPR7ES-11	
MS 851 242	BP4EY	
MS 851 243	BP5EY	
MS 851 244	BP6EY	
MS 851 246	BP4EY-11	
MS 851 247	BP5EY-11	
MS 851 248	BP6EY-11	
MS 851 253	BUR6EA-11	
MS 851 254	BUR7EA-11	
MS 851 273	BUR6EA-11	
MS 851 274	BUR7EA-11	
MS 851 283	BP6E	4
MS 851 286	BP5EY	
MS 851 287	BP6EY	
MS 851 292	PGR6A-11	
MS 851 301	PGR5A-11	
MS 851 302	PGR6A-11	
MS 851 316	DCPR6E	
MS 851 317	DCPR7E	
MS 851 327	DCPR7EIX	
MS 851 332	PFR6B-11	
MS 851 335	PFR5J-11	
MS 851 336	PFR6J-11	
MS 851 346	PFR6M	
MS 851 347	PFR7M	
MS 851 351	BK5E	
MS 851 352	BK6E	
MS 851 353	BK6E	
MS 851 354	BK5E	
MS 851 357	BKR5E-11	33
MS 851 358	BKR6E-11	14
MS 851 359	BKR7E-11	
MS 851 361	BK5E-11	
MS 851 362	BK6E-11	
MS 851 363	BKR7E-11	
MS 851 364	BK5E-11	
MS 851 365	BK6E-11	
MS 851 366	BKR7E-11	

MITSUBISHI	→ NGK	V-Line
MS 851 367	BKR5E	35
MS 851 368	BKR6E	28
MS 851 382	BKR6E	28
MS 851 387	BKR5E-11	33
MS 851 388	BKR6E-11	14
MS 851 396	DCPR6E	
MS 851 397	DCPR7E	
MS 851 402	BPR5E	6
MS 851 403	BPR6ES-11	13
MS 851 408	BPR6ES-11	13
MS 851 412	BPR5ES	6
MS 851 413	BPR6ES	2
MS 851 414	BPR7ES	19
MS 851 417	BPR5ES-11	
MS 851 418	BPR6ES-11	13
MS 851 419	BPR7ES-11	
MS 851 428	BUR6EA-11	
MS 851 429	BUR7EA-11	
MS 851 437	BP5EY	
MS 851 438	BP6ES	4
MS 851 439	BP7ES	
MS 851 447	BUR6EA-11	
MS 851 454	BR7ES	
MS 851 463	PGR6A-11	
MS 851 473	PFR6B-11	
MS 851 478	BPR6ES-11	13
MS 851 486	DCPR6E	
MS 851 487	DCPR7E	
MS 851 497	DCPR7EIX	
MS 851 501	PFR5J-11	
MS 851 502	PFR6J-11	
MS 851 506	PFR6J	
MS 851 721	BK5E	
MS 851 722	BK6E	
MS 851 727	BKR5E-11	33
MS 851 728	BKR6E-11	14
MS 851 729	BKR7E-11	
MS 851 732	BK6E-11	
MS 851 737	BKR5E	35
MS 851 738	BKR6E	28
MS 851 783	BK7EK-N-11	
MS 851 861	PFR6J	
MS 851 872	BK7EK-N-11	
MS 851 881	BPR6EKN	
MS 851 882	BPR7EKN	
MZ 602 020	BKR5EIX-11	
MZ 602 021	BKR6EIX-11	
MZ 602 022	IRIWAY7	
MZ 602 023	IRIWAY8	
MZ 602 024	IRIWAY9	
MZ 602 026	BCPR5EIX-11	
MZ 602 027	BCPR6EIX-11	

MITSUBISHI	→ NGK	V-Line
MZ 602 028	IRITOP7	
MZ 602 029	IRITOP8	
MZ 602 030	IRITOP9	
MZ 602 032	BPR5EIX-11	
MZ 602 033	BPR6EIX-11	
MZ 602 034	BPR7EIX	
MZ 602 035	BR8EIX	
MZ 602 036	BR9EIX	
MZ 602 037	DCPR7EIX	
MZ 602 039	IRIMAC9	
MZ 602 040	BKR5EIX-11P	
MZ 602 041	BKR6EIX-11P	
MZ 602 042	BKR7EIX-P	
MZ 602 043	BCPR5EIX-11P	
MZ 602 044	BCPR6EIX-11P	
MZ 602 049	DCPR7EIX-P	
MZ 602 060	BPR5EIX-11	
MZ 602 061	BPR6EIX-11	
MZ 602 062	BPR7EIX	
MZ 602 063	BCPR5EIX-11	
MZ 602 064	BCPR6EIX-11	
MZ 602 065	BKR5EIX-11	
MZ 602 066	BKR6EIX-11	
MZ 602 067	DCPR7EIX	
MZ 602 068	ZFR5FIX-11	
MZ 602 069	ZFR6FIX-11	
MZ 602 070	BPR5EIX	
MZ 602 071	BPR6EIX	
MZ 602 072	BKR5EIX	
MZ 602 073	BKR6EIX	
MZ 602 074	LPG2	
MZ 602 075	LPG1	
MZ 602 076	BKR5EIX-11P	
MZ 602 077	BKR6EIX-11P	
MZ 602 078	BCPR5EIX-11P	
MZ 602 079	BCPR6EIX-11P	
MZ 602 080	DCPR7EIX-P	
MZ 602 081	BKR7EIX-11	
MZ 602 082	BKR5EIX-P	
MZ 602 083	BKR6EIX-P	
MZ 602 084	ZFR5FIX-11P	
MZ 602 085	ZFR6FIX-11P	
S MD 313 443	PFR6G-11	
S MN 158 596	LZFR6AI	
SS MS 851 364	BK5E-11	
Z2 152 944	BPR6ES-11	13
Z2 152 945	BPR6ES	2
Z2 152 946	BR7ES	
Z2 152 947	BPR7ES	19
Z2 152 948	BPR7ES-11	
Z2 152 949	BCPR7ES-11	
Z2 152 950	BCPR6ES-11	11

NISSAN	→ NGK	V-Line
22401-00Q0K	ILKAR7F7G	
22401-01B14	BPR5ES-11	
22401-01P14	BCPR4ES-11	
22401-01P15	BCPR5ES-11	
22401-01P16	BCPR6ES-11	11
22401-01P17	BCPR7ES-11	
22401-01P75	BCPR5ES-11	
22401-01P76	BCPR6ES-11	11
22401-01P90	BCPR5ES-11	
22401-01P91	BCPR6ES-11	11
22401-02P15	BCPR5E-11	
22401-02P16	BCPR6E-11	11
22401-02P17	BCPR7E-11	
22401-03300	B-4	
22401-08U15	PFR5K-11	
22401-08U75	PFR5K-11	
22401-10F14	BCPR4ES-11	
22401-10F15	BCP5ES	16
22401-10F16	BCP6ES	17
22401-10F17	BCP7ES	
22401-10P15	BCPR5E-11	
22401-10P16	BKR6E-11	14
22401-10P17	BCPR7E-11	
22401-11200	BC6ES	
22401-12E14	BCPR4ES-11	
22401-12E15	BCPR5ES	32
22401-12E16	BCPR6ES	12
22401-12E17	BCPR7ES	
22401-12E76	BCPR6ES	12
22401-18V15	PGR5A	
22401-18V16	PGR6A	
22401-18V17	PGR7A	
22401-19V15	BCP5ES	16
22401-19V16	BCP6ES	17
22401-19V17	BCP7ES	
22401-19V65	BCPR5ES	32
22401-19V66	BCPR6ES	12
22401-1A50A	ILFR5B11	
22401-1F720	BKR5E-11	33
22401-1HA1C	DILKAR7E11HS	
22401-1HC1B	LZKAR6AP-11	
22401-1KC1C	DILKAR7C9H	
22401-1KC7C	DILKAR7C9H	
22401-1KT1B	DILZKAR6A11	
22401-1KT7B	DILZKAR6A11	
22401-1LA1C	DILKAR7B11	
22401-1LA7C	DILKAR7B11	
22401-1N506	BKR6E-N	
22401-1N516	BKR6E-N	
22401-1N517	BKR7E	
22401-1N567	PFR7G-11	
22401-1P114	PFR4G-11	

NISSAN	→ NGK	V-Line
22401-1P115	PFR5G-11	
22401-1P116	PFR6G-11	
22401-1P117	PFR7G-11	
22401-1P175	PFR5G-11	
22401-1P175-Q0	PFR5G-11	
22401-1P175-VA	PFR5G-11	
22401-1P176	PFR6G-11	
22401-1P176-VA	PFR6G-11	
22401-1P176-WS	PFR6G-11	
22401-1TT1C	DILKAR7E9HS	
22401-1VA1C	DILKAR7D11H	
22401-1VA7C	DILKAR7D11H	
22401-1W615	FR5AP-10	
22401-1W675	FR5AP-10	
22401-20J04	BKR4E	
22401-20J05	BKR5E	35
22401-20J05-Q0	BKR5E	35
22401-20J05-SN	BKR5E	35
22401-20J05-VA	BKR5E	35
22401-20J05-W0	BKR5E	35
22401-20J06	BKR6E	28
22401-20J07	BKR7E	
22401-20J16	BKR6E	28
22401-21B15	BPR5E	6
22401-21B16	BPR6E	2
22401-21B17	BPR7E	19
22401-27N15	PFR5B-11	
22401-27N15-VA	PFR5B-11	
22401-27N15-VB	PFR5B-11	
22401-27N16	PFR6B-11	
22401-27N64	PFR4G-11	
22401-27N65	PFR5B-11	
22401-27N66	PFR6B-11	
22401-27N67	PFR7B-11	
22401-27T15	PGR5A-11	
22401-27T65	PGR5A-11	
22401-27T66	PGR6A-11	
22401-2J200	BKR5EY-11	
22401-2J200-Q0	BKR5EY-11	
22401-2J200-VA	BKR5EY-11	
22401-2J206	BKR6EY-11	
22401-2J206-VA	BKR6EY-11	
22401-30R14	ZFR4E-11	
22401-30R15	ZFR5E-11	
22401-30R16	ZFR6E-11	
22401-30R75	ZFR5E-11	
22401-30R75-W1	ZFR5E-11	
22401-37P16	PFR6B-11C	
22401-37P76	PFR6B-11C	
22401-40F15	ZFR5D-11	
22401-40P15	PFR5B-11B	
22401-40P65	PFR5B-11B	



NISSAN	→ NGK	V-Line
22401-40P66	PFR6B-11B	
22401-40V05	BCP5E	16
22401-40V06	BCP6E	17
22401-40V07	BCPR7E	
22401-50Y04	BKR4E-11	
22401-50Y05	BKR5E-11	33
22401-50Y05-Q0	BKR5E-11	33
22401-50Y05-VA	BKR5E-11	33
22401-50Y05-W0	BKR5E-11	33
22401-50Y06	BKR6E-11	14
22401-50Y07	BKR7E-11	
22401-50Y75	BKR5E-11	33
22401-50Y75-W0	BKR5E-11	33
22401-53J04	BKR4EY	
22401-53J05	BKR5EY	
22401-53J05-VA	BKR5EY	
22401-53J06	BKR6EY	
22401-53J06-RB	BKR6EY	
22401-53J06-VA	BKR6EY	
22401-53J07	BKR7EY	
22401-53J15	PFR5B-9	
22401-53J65	PFR5B-9	
22401-53J66	PFR6B-9	
22401-53J67	PFR7B-9	
22401-53V15	PFR5B-9	
22401-53V16	PFR6B	
22401-53V17	PFR7B	
22401-55V17	PFR7B-D	
22401-58S15	PFR5A-11	
22401-58S16	PFR6A-11	
22401-58S17	PFR7A-11	
22401-59S16	PFR6A-11	
22401-5M015	PLFR5A-11	
22401-5M016	PLFR6A-11	
22401-5M075	PLFR5A-11	
22401-5M075-Q0	PLFR5A-11	
22401-5M075-SN	PLFR5A-11	
22401-5M075-VA	PLFR5A-11	
22401-5M075-W0	PLFR5A-11	
22401-60V06	BCPR6ES-11	11
22401-6N215	LZFR5AQP	
22401-85E15	BKR5ES-11	33
22401-85E16	BKR6ES-11	14
22401-85E17	BKR7ES-11	
22401-85E75	BKR5ES-11	33
22401-85E76	BKR6ES-11	14
22401-88G75	BKR5EY	
22401-88G75-WS	BKR5EY	
22401-88G76	BKR6EY	
22401-88G76-WS	BKR6EY	
22401-8H314	LFR4AP-11	
22401-8H315	LFR5AP-11	

NISSAN	→ NGK	V-Line
22401-8H375	LFR5AP-11	
22401-8H375-VA	LFR5AP-11	
22401-8H515	LFR5A-11	
22401-8H575	LFR5A-11	
22401-8H575-Q0	LFR5A-11	
22401-8H616	PLFR6A-9	
22401-8H676	PLFR6A-9	
22401-8P305	BKR5EQUPA	
22401-8P315	BKR5EQUPA	
22401-8P375	BKR5EQUPA	
22401-97E15	PFR5C-11	
22401-97E65	PFR5C-11	
22401-98E06	BKR6ES-11	14
22401-9E075	FR5AP-10	
22401-AG214	PFR4G-11	
22401-AG215	PFR5P-11	
22401-AG275	PFR5P-11	
22401-AG315	BKR5EQUPA	
22401-AJ415	FR5AP-11	
22401-AL615	LFR5AQP	
22401-AL875	LFR5BP-11	
22401-AR015	LFR5AQP	
22401-BC01B	LFR5E-11	
22401-CK81	PLZKAR6A-11	51
22401-CK81B	PLZKAR6A-11	51
22401-CK87B	PLZKAR6A-11	51
22401-CK87B-VA	PLZKAR6A-11	51
22401-EA015	PLZKAR6A-11	51
22401-ED815	LZKAR6AP-11	
22401-ED875	LZKAR6AP-11	
22401-ED875-Q0	LZKAR6AP-11	
22401-ED875-SN	LZKAR6AP-11	
22401-ED875-VA	LZKAR6AP-11	
22401-EW61B	DILKAR6A11	
22401-EW61C	DF7H-11B	
22401-EW67B	DILKAR6A11	
22401-EW68C	DF7H-11B	
22401-F6516	PFR6A-11A	
22401-HC000	BPR5ES-13	
22401-HC001	BPR6EIX-11	
22401-JA01B	DILKAR6A11	
22401-JA07B	DILZKAR6A11	
22401-JF01D	DILKAR8A8	
22401-JK01D	DF8H-11B	
22401-M7715	B5ES	
22401-M7716	B6ES	
22401-M7717	B7ES	
22401-M7915	BR5ES	
22401-M7916	BR6ES	
22401-M7917	BR7ES	
22401-N8714	BP4ES-11	
22401-N8715	BP5ES-11	

NISSAN	→ NGK	V-Line
22401-N8716	BP6ES-11	
22401-N8717	BP7ES-11	
22401-N8785	BP5ES-11	
22401-N8786	BP6ES-11	
22401-N8789	BP6ES-11	
22401-N8790	BP5ES-11	
22401-N8791	BP6ES-11	
22401-P8314	BPR4ES-11	
22401-P8315	BPR5ES-11	
22401-P8316	BPR6ES-11	13
22401-P8317	BPR7ES-11	
22401-P8385-PC	BPR5ES-11	
22401-P8386-PC	BPR6ES-11	13
22401-P8389	BPR4ES-11	
22401-P8390	BPR5ES-11	
22401-P8391	BPR6ES-11	13
22401-P8616	BR6ES-11	
22401-P8617	BR7ES	
22401-P8816	B6ES-11	
22401-P8817	B7ES-11	
22401-S6015	BP5ES-13	
22401-S6016	BPR6EIX-11	
22401-V0515	BP5ES	8
22401-V0516	BP6ES	4
22401-V1414	BPR4ES	
22401-V1414-WL	BPR4ES	
22401-V1415	BPR5ES	6
22401-V1416	BPR6ES	2
22401-V1417	BPR7ES	19
22401-V1484-PC	BPR4ES	
22401-V1485-PC	BPR5ES	6
22401-V1486-PC	BPR6ES	2
22401-V1490	BPR5ES	6
22401-V1491	BPR6ES	2
22401-V5014	BCPR4ES-11	
22401-V5015	BCP5ES-11	
22401-V5016	BCP6ES-11	
22401-V5017	BKR7E-11	
22401-V5085	BCP5ES-11	
22401-V5086	BCP6ES-11	
22401-VB000	BPR5E-11	
22401-VB006	BPR6E-11	
22401-VR306	IGR6B-10D	
22401-W8914	BP4ES	
22401-W8914-WL	BP4ES	
22401-W8915	BP5ES	8
22401-W8915-SA	BP5ES	8
22401-W8916	BP6ES	4
22401-W8917	BP7ES	
22401-W8985	BP5ES	8
22401-W8985-PC	BP5ES	8
22401-W8986	BP6ES	4

NISSAN	→ NGK	V-Line
22401-W8986-PC	BP6ES	4
22401-W8990	BP5ES	8
22401-W8991	BP6ES	4
22401-W9815	BPR5ES	6
22401-W9816	BPR6ES	2
22401-W9817	BPR7ES	19
22401-WA016	PFR6G-9	
22401-WA066	PFR6G-9	
22401-WA067	PFR7G-9	
22401-WD517	FR7AI-D	
22401-Y9015	BCPR5ET	
22401-Y9016	BCPR6ET	
22401-Y9017	BCPR7ET	
22401-Y9065	BCPR5ET	
22401-Y9066	BCP6ET	
22401-Y9067	BCP7ET	
22401-Y9215	BPR5ES	6
22401-Y9264	BP4ES	
22401-Y9265	BP5ES	8
22401-Y9266	BP6ES	4
22401-ZE01B	DILFR5A11	
B2401-00QAA	BKR6EZ	38
B2401-4A00A	IKR6G11	
B2401-89900	BPR5EIX	
B2401-89904	BP5EY	
B2401-89905	BP6EY	
B2401-89906	BCPR5EIX-11	
B2401-89907	BCPR6EIX-11	
B2401-89908	BPR5EY	9
B2401-89909	BPR6EY	
B2401-M7715	B5ES	
B2401-M7915	BR5ES	
B2401-V1415	BPR5ES	6
B2401-V1416	BPR6ES	2
B2401-W8914	BP4ES	
B2401-W8915	BP5ES	8
B2401-W8916	BP6ES	4
B2401-W8917	BP7ES	
BY480-BKR5E	BKR5EIX	
BY480-BKR6E	BKR6EIX	
BY480-BPR5E	BPR5EIX	
BY480-BPR6E	BPR6EIX	
BY480-BPR7E	BPR7EIX	
BY480-BPR8E	BPR8EIX	
BY480-BPR9E	BPR9EIX	
BY480-DCPR7	DCPR7EIX	
BY481-BCPR5	BCPR5EIX-11	
BY481-BCPR6	BCPR6EIX-11	
BY481-BKR5E	BKR5EIX-11	
BY481-BKR6E	BKR6EIX-11	
BY481-BKR7E	BKR7EIX-11	
BY481-BPR5E	BPR5EIX-11	



NISSAN	→ NGK	V-Line
BY481-BPR6E	BPR6EIX-11	
BY481-LFR5A	LFR5AIX-11	
BY481-LFR6A	LFR6AIX-11	
BY481-ZFR5F	ZFR5FIX-11	
BY481-ZFR6F	ZFR6FIX-11	
BY482-BKR6E	LPG1	
BY482-BPR6E	LPG2	
BY483-BCPR5	BCPR5EIX-11P	
BY483-BCPR6	BCPR6EIX-11P	
BY483-BKR5E	BKR5EIX-11P	
BY483-BKR6E	BKR6EIX-11P	
BY483-HB6AI	HB6AIX-11P	
BY483-HB6BI	HB6BIX-11P	
BY483-LFR5A	LFR5AIX-11P	
BY483-LFR6A	LFR6AIX-11P	
BY483-ZFR5F	ZFR5FIX-11P	
BY483-ZFR6F	ZFR6FIX-11P	
BY484-BKR5E	BKR5EIX-P	
BY484-BKR6E	BKR6EIX-P	
BY484-BKR7E	BKR7EIX-P	
BY484-DCPR7	DCPR7EIX-P	
BY484-LFR6A	LFR6AIX-P	
BY484-LFR7A	LFR7AIX-P	
OPEL	→ NGK	V-Line
12 14 014	PZTR5A-15	
12 14 016	ZFR6V-G	
12 14 030	PFR6T-10G	
12 14 031	ZFR5F	53
12 14 046	PFR6T-G	
12 14 060	PFR6D10G	
12 14 065	DILFR7B10G	
12 14 066	IFR7X7G	
12 14 149	BKR5EK	23
12 14 527	PLFR6C-10G	
12 14 528	ZFR6BP-G	
44 13 288	PFR6G-9	
47 08 892	IKR6G11	
48 11 581	ILTR5D	
12 563 707	PZTR5A-15	
12 620 540	ILTR5D	
12 787 099	PFR6T-10G	
12 788 884	PLFR6C-10G	
25 324 618	LTR6B-10T	
55 182 623	FR5CP	
55 562 534	PFR6T-G	
55 564 215	BKR7ESC-11	
55 564 748	DILFR7B10G	
55 564 763	ZFR6BP-G	
55 565 219	ZFR6V-G	
55 571 391	PFR6D10G	
55 576 026	IFR7X7G	
90 239 568	BPR6ES	2

OPEL	→ NGK	V-Line
90 239 569	BPR6HS	3
90 336 461	BKR6ES	28
90 338 179	BCPR6ET	
90 355 136	BPR6ES	2
90 356 323	BPR5ES	6
90 357 729	BKR6EK	20
90 357 780	BKR6ES	28
90 423 215	BKR6ES	28
90 512 989	BKR5EK	23
93 161 199	PFR6G-9	
93 193 723	IKR6G11	
PORSCHE	→ NGK	V-Line
955 170 220 90	ILZKR7A	
958 170 222 90	ILZKR8A	
999 170 223 90	BKR7EQU	
PSA	→ NGK	V-Line
5960.14	LFR5B	46
5960.81	PLFR5A-11	
5960.92	PLZKBR7B8G	
5960.93	PLZKBR7B8G	
5960.A5	PLZKBR7B8G	
5960.C2	FR5EI	
5960.C3	FR5EI	
5960.E1	PLZKBR7B8G	
5960.E2	PLZKBR7B8G	
5960.F3	LFR6B	47
5960.G4	PLZKBR7B8G	
5960.H9	PLZKBR7B8G	
5960.L0	PLZKBR7B8G	
5960.L5	ILZKBR7B8G	
5962.00	BCP6ES	17
5962.05	BP6EFS	5
5962.09	BP6EFS	5
5962.13	BP6ES	4
5962.14	BP6EFS	5
5962.15	BP6EFS	5
5962.16	BP6ES	4
5962.21	BUR6ET	1
5962.22	BPR6EIX	
5962.2A	BPR6ES	2
5962.2T	BKR6EKC	26
5962.2X	BKR6ES	28
5962.5G	BKR6EZ	38
5962.71	BKR6ES	28
5962.72	BP6EFS	5
5962.7S	BKR6EZ	38
5962.7W	LFR6B	47
5962.7Y	LFR6B	47
5962.80	BP6HS	18
5962.82	BP6ES	4
5962.87	BP6EFS	5
5962.88	BP8ES	

PSA	→ NGK	V-Line
5962.90	BP6HS	18
5962.94	BP7ES	
5962.98	BP7ES	
5962.A1	BP7ES	
5962.A2	BP6ES	4
5962.A3	BP6HS	18
5962.A5	PLZKBR7B8G	
5962.AO	BP7ES	
5962.C5	BKR6ES	28
5962.C6	BKR6ES	28
5962.CO	BP5EFS	
5962.F7	BCP6ES	17
5962.F8	BCP6ES	17
5962.G8	BP7ES	
5962.H2	BKR6ES	28
5962.H8	BKR5ES	35
5962.H9	BKR5ES	35
5962.IA	BP5ET	
5962.IK	BKR6EK	20
5962.IL	BKR5EK	23
5962.J9	BKR6ES	28
5962.JO	BCP6ES	17
5962.K1	BCPR7ES	
5962.K3	BCP7ET	
5962.K4	BKR6ES	28
5962.K6	BKR6ES	28
5962.K7	BCPR6ET	
5962.KO	BCPR7ES	
5962.OE	BKR6EK	20
5962.R5	BCPR6ET	
5962.R9	BKR6ES	28
5962.S2	BKR6ES	28
5962.S4	BKR5ES	35
5962.S7	BP5ES	8
5962.T8	BKR6ES	28
5962.TO	BKR6ES	28
5962.V6	BKR5ES	35
5962.V7	BKR6ES	28
5962.V8	BCPR7ES	
5962.W1	BKR5ES	35
5962.W4	BCPR6ET	
5962.W6	BCPR7ES	
5962.W7	BCPR7ES	
5962.W9	BKR5EK	23
5962.X5	BCP6ES	17
5962.X8	BCP6ES	17
5962.Y2	BKR5EK	23
5962.Y8	BKR6EK	20
5962.Z1	BKR6EK	20
5962.Z6	BKR5EK	23
5962.ZO	BKR6EK	20
7355.92	BPR6HS	3

PSA	→ NGK	V-Line
7369.54	BR7HS	
7369.75	BR7ES	
7370.27	BPR5HS	
7381.55	BR8ES	
7567.57	B6HS	
7567.58	BP5HS	
7567.59	B7HS	
7567.60	B8HS	
7567.61	BP6HS	18
7567.62	B9ES	
7567.63	B9HS	
7567.66	B8ES	
7567.70	B6ES	
7604.64	BPR7ES	19
11 737 027 00	BPR5HS	
16 075 776 80	DILFR5A11	
95 496 692	BP6HS	18
95 605 398	B6HS	
95 611 941	BP6EFS	5
95 619 043	BP6ES	4
96 000 090	BCP5ES	16
96 037 952	BCP5ES	16
96 039 962	BCP6ET	
96 064 890	BKR5ES	35
96 097 486	BCP7ET	
96 145 071	BCPR6ET	
96 762 881 80	LZKR6AI-10G	
96 774 469 80	ILZKR8C8G	
97 533 994	BP7EFS	
AM 212 207 A	B6HS	
MKP 00073	BP7ES	
V7 534 226 80	PLZKBR7B8G	
V7 534 226 80-03	PLZKBR7B8G	
V7 570 106 80	ILZKBR7B8G	
ZC 986 209 0U	BP5ES	8
ZCT 000 011	BP6HS	18
ZCT 000 012	BP7ES	
RENAULT	→ NGK	V-Line
22 40 100 32R	LZKAR7D-9D	
22 40 115 61R	LZKAR7D-9D	
22 40 11K C1C	DILKAR7C9H	
22401-1TT1C	DILKAR7E9HS	
22401-2047R	ILKAR7F7G	
22 40 143 78R	LZKAR7B	
22 40 191 33R	ILKAR7J7G	
224019-185R	SILZKFR8D7G	
22 40 192 02R	LZKAR7B	
22 40 1EA 015	PLZKAR6A-11	51
22 40 1JA 01B	DILKAR6A11	
74 39 146 775	BCPR5ET	
77 00 101 401	BKR5ES	35
77 00 103 502	BPR5ES	6



RENAULT	→ NGK	V-Line
77 00 103 503	BPR5ES	6
77 00 103 533	BKR5EK	23
77 00 107 916	BKR5EK	23
77 00 115 827	BKR6EK	20
77 00 260 637	BCP7ET	
77 00 266 295	BPR6EFS	7
77 00 267 140	BPR6EFS	7
77 00 267 805	TR7IX	
77 00 273 462	BKR6ES	28
77 00 273 698	BKR6EIX	
77 00 500 132	BKR6ETUC	
77 00 500 168	BKR6E	28
77 00 553 622	BP6ES	4
77 00 565 155	BR9EIX	
77 00 587 168	BP6HS	18
77 00 714 540	BPR6EFS	7
77 00 722 095	BP6EFS	5
77 00 724 821	BP6ES	4
77 00 725 302	BPR5ES	6
77 00 726 503	BP7EFS	
77 00 727 383	BPR6ES	2
77 00 731 583	BP7EFS	
77 00 732 626	BP8ES	
77 00 733 422	BP5HS	
77 00 736 149	BP7EFS	
77 00 736 150	BP7EFS	
77 00 737 457	BP7EFS	
77 00 737 458	BP6EFS	5
77 00 737 459	BP7ES	
77 00 737 612	BCP5ES	16
77 00 742 094	BPR7ES	19
77 00 743 137	BCP5ES	16
77 00 743 920	BP5ES	8
77 00 749 163	BCP5ES	16
77 00 824 821	BP6ES	4
77 00 852 522	BP6EFS	5
77 00 852 543	TR7IX	
77 00 855 463	BCP6ET	
77 00 855 918	BP5EFS	
77 00 856 342	BCP6ET	
77 00 859 910	BCP5ES	16
77 00 859 967	BP5ES	8
77 00 860 235	BP5ESZ	
77 00 861 471	BP7ES	
77 00 861 472	BP6ESZ	
77 00 862 054	BP5ES	8
77 00 868 864	BPR7ES	19
77 00 869 200	BK5ESZ	
77 00 871 617	BCPR6ET	
77 01 021 767	BP6EFS	5
77 01 041 021 4	BP5ES	8
77 01 041 214	BP5ES	8

RENAULT	→ NGK	V-Line
77 01 041 215	BP6EFS	5
77 01 042 816	BKR6ES	28
77 01 043 624	BCPR6ET	
77 01 045 018	BP7EFS	
77 01 065 085	PLZKAR6A-11	51
77 01 366 057	BP6HS	18
77 01 366 084	BR8EIX	
77 01 366 085	BR7EIX	
77 01 366 086	BP6ES	4
77 01 366 087	BP7ES	
77 01 366 137	BP6EFS	5
77 01 366 267	BP6HS	18
77 01 366 268	BP7ES	
77 01 366 269	BP6ES	4
77 01 366 270	BP6EFS	5
77 01 366 513	BP5HS	
77 01 366 514	BP6EFS	5
77 01 366 515	BP6HS	18
77 01 366 516	BP6ES	4
77 01 366 533	B6HS	
77 01 366 539	BP5ES	8
77 01 366 903	BP5ES	8
77 01 414 022	BP5HS	
77 01 414 025	BP6ES	4
77 01 414 026	BP7EFS	
77 01 414 027	BP7EFS	
77 01 414 031	BPR6ES	2
77 01 414 105	BP5ESZ	
82 00 020 791	BKR6EZ	38
82 00 027 363	BKR5EK	23
82 00 030 765	LZKAR7B	
82 00 046 337	PFR6G-9	
82 00 239 321	PFR6E-10	
82 00 314 928	PFR7G-9	
82 00 322 273	LZKAR7A	54
82 00 332 273	LZKAR7B	
82 00 363 364	PFR6G-9	
82 00 363 384	PFR6G-9	
82 00 492 426	PFR7ZTG	
82 00 587 901	ILKAR7A7	
82 00 592 215	LZKAR7B	
82 00 662 185	LZKAR7B	
82 01 001 947	IFR7X8G	
83 04 504 277	ZFR5F	53
86 71 016 890	LZKAR7B	
88 03 343 3	IGR7E-3D	
89 33 003 862	BKR6ES	28
96 26 575 480	BKR6EK	20
96 32 182 880	PFR6E-10	
ROLLS-ROYCE	→ NGK	V-Line
RH12 050	GR4IX	
RH13 998	BKR5EIX	



ROVER	→ NGK	V-Line
NLP 100 260	BPR6E	2
NLP 100 290	PFR6N-11	
SAAB	→ NGK	V-Line
12 14 060	PFR6D10G	
12 14 065	DILFR7B10G	
45 71 808	PFR7H-10	
48 11 581	ILTR5D	
56 92 485	BCPR7EIX	
59 58 780	BCPR5EIX	
59 58 798	BCPR6EIX	
59 62 485	BCPR7EIX	
88 19 294	BCP6ES	17
88 19 302	BCPR7EIX	
88 19 328	BPR7EIX	
91 12 541	BCPR7ES-11	
91 16 385	BCP5ES	16
91 17 565	BCPR6ES-11	11
91 36 276	BCPR5EIX	
91 39 643	BCPR6EIX	
91 71 307	BKR7ES-11	
91 85 398	PFR7H-10	
91 88 681	PFR7H-10	
93 99 866	PFR6H-10	
12 620 540	ILTR5D	
12 787 099	PFR6T-10G	
12 788 884	PLFR6C-10G	
15 885 210	BCPR7ES-11	
30 520 467	BCPR6ES-11	11
32 000 330	BCPR7ES-11	
55 564 215	BKR7ESC-11	
55 564 748	DILFR7B10G	
55 564 763	ZFR6BP-G	
55 571 391	PFR6D10G	
83 500 768	BCP7ES	
SCANIA	→ NGK	V-Line
14 67 698	IFR7U-4D	
SSANGYONG	→ NGK	V-Line
162 159 31 03	BKUR5ETZ-10	
A 162 159 31 03	BKUR5ETZ-10	
SUBARU	→ NGK	V-Line
22401-AA000	BP5ES-11	
22401-AA010	BP6ES-11	
22401-AA020	BP6ES	4
22401-AA030	BP6ES	4
22401-AA080	BP6EY	
22401-AA090	BP7ES	
22401-AA100	BE527Y-11	
22401-AA110	BE527Y-11	
22401-AA120	BPR6ES-11	13
22401-AA130	BPR6ES-11	13
22401-AA200	BPR6ES	2
22401-AA210	BPR7ES	19

SUBARU	→ NGK	V-Line
22401-AA220	BPR6ES	2
22401-AA230	BPR7E	19
22401-AA310	BKR6E-11	14
22401-AA320	BKR6E-11	14
22401-AA360	PFR7B	
22401-AA370	PFR6B-11	
22401-AA376	PFR6G-11	
22401-AA380	BRE527Y-11	
22401-AA390	BRE527Y-11	
22401-AA400	PFR6B	
22401-AA460	BPR5EY-11	
22401-AA470	BPR6EY-11	10
22401-AA480	BPR5ES-11	
22401-AA500	BKR6EIX-11	
22401-AA510	BKR6EIX	
22401-AA520	PFR6G-11	
22401-AA530	PFR6G	
22401-AA531	PFR6G	
22401-AA570	PFR5B-11	
22401-AA580	PLFR6A-11	
22401-AA600	PFR7G	
22401-AA610	ZFR6FIX-11	
22401-AA630	ILFR6B	
22401-AA650	FR5AP-11	
22401-AA65A	FR5AP-11	
22401-AA670	SILFR6A	
22401-AA680	ILFR6B	
22401-AA700	DILFR6D11	
22401-AA720	SILFR6A11	
22401-AA730	SIFR6A11	
22401-AA750	SILFR6C11	
22401-AA780	SILZKAR7B11	
22401-AA820	DILZKAR7B11	
22401-AA830	ILKAR8H6	
22401-AA870	SILKAR8D6	
22401-KA000	BUR6EA-11	
22401-KA010	BKR6E-11	14
22401-KA030	BKR6E-11	14
22401-KA050	BUR6EA-11	
22401-KA060	BUR6EA-11	
22401-KA080	BKR6E	28
22401-KA090	BCPR6E	12
22401-KA100	BCPR6E	12
22401-KA130	BPR6ES	2
22401-KA140	ZFR6G	
22401-KA150	BKR6E	28
22401-KA160	ZFR6G	
22401-KA170	ZFR5G	
22401-KA180	ZFR5G	
22401-KA190	BPR5E-11	
22401-KA200	BKR5E-11	33
22401-KA210	BKR6ES-11	14

SUBARU	→ NGK	V-Line
22401-KA240	DCPR7E	
22401-KA260	DCPR7E	
22401-KA290	BKR4E-11	
22401-KA310	DCPR8E	
22401-KA320	DCPR8EIX	
22401-KA340	KR8BI	
22401-KA430	BKR6EKPA	
22401-KA440	BKR5E	35
22401-KA450	LKR7AI	
32054-0800	B6ES	
32054-1110	B7ES	
32054-1120	BR7EIX	
32054-5700	BR6ES	
38028-0102	BP6EY	
38242-0800	B5ES	
42054-3200	BP5ES	8
42054-5502	BP6ES	4
42054-5602	BP5EY-11	
42054-5702	BP6ES-11	
42054-5800	BE529Y-11	
42054-5802	BE529Y-11	
42054-7102	BP5EY	
42054-7302	BP5EY-11	
48028-7100	BP4EY-11	
49001-0003	BPR5EIX	
49001-0013	BPR6EIX	
49001-0023	BPR7EIX	
49001-0033	BPR5ES	6
49001-0043	BP5EY	
49001-0053	BP6EY	
49001-0082	BPR5EY	9
49001-0092	BPR6EY	
82054-1810	B6HS	
82054-1812	B6HS	
82054-6010	B8HS	
82054-7820	BR6HIX	
82054-8020	BR8HIX	
82054-8600	B6ES	
82054-9310	B7HS	
82054-9312	B7HS	
82054-9320	BR7HIX	
88241-7800	B5HS	
89057-3400	B6S	
SAB 330 DE 0710	BKR5EIX-11P	
SAB 330 DE 0720	BKR6EIX-11P	
SAB 330 DE 0730	BKR7EIX-P	
SAB 330 DE 0800	DCPR7EIX-P	
SAB 330 DE 2640	LFR6AIX-11	
SAB 330 DE 2670	LFR6AIX-11P	
SAB 330 DE 2680	LFR7AIX-P	
SAB 330 DE 2800	BKR6EIX-P	
SAB 330 DE 3360	BKR5EIX-11	

SUBARU	→ NGK	V-Line
SAB 330 DE 3370	BKR6EIX-11	
SAB 330 DE 3430	DCPR7EIX	
SAB 330 DE 3450	IRIWAY7	
SAB 330 DE 3710	BKR5EIX-11P	
SAB 330 DE 3720	BKR6EIX-11P	
SAB 330 DE 3730	BKR7EIX-P	
SAB 330 DE 3800	DCPR7EIX-P	
SAB 330 DE 3950	BKR6EIX-P	
SAB 330 DE 4540	LFR6AIX-P	
SAB 330 DE 5140	LFR6AIX-11	
SAB 330 DE 5150	LFR6AIX-11P	
SAB 330 DE 5170	LFR7AIX-P	
SAB 330 DE 5260	LFR6AIX-P	
SAB 330 DE 5270	LFR7AIX-P	
SAB 330 DE 8430	IRIWAY7	
SAB 330 DE 8640	IFR5E11	
SAB 330 DE 8680	BKR5EIX-11	
SAB 330 DE 8690	BKR6EIX-11	
SAB 330 DE 8720	DCPR7EIX	
SUZUKI	→ NGK	V-Line
09482-00006	B-4	
09482-00051	B6S	
09482-00053	B7S	
09482-00054	B6ES	
09482-00056	B8ES	
09482-00059	BP6HS	18
09482-00060	BP7HS	
09482-00064	BR6HIX	
09482-00065	BR7HIX	
09482-00066	B9ES	
09482-00074	BP6HS	18
09482-00079	BR6ES	
09482-00082	B7HS	
09482-00083	B7HS	
09482-00084	BP6HS	18
09482-00089	B7ES	
09482-00091	B8ES	
09482-00095	B6HS	
09482-00096	BR8EIX	
09482-00097	BR9EIX	
09482-00105	BP7HS	
09482-00114	BR8EIX	
09482-00115	BR9EIX	
09482-00116	BR7HS	
09482-00117	BR7ES	
09482-00118	BP6ES	4
09482-00120	BP5HS	
09482-00121	BR8ES	
09482-00123	BP5EY	
09482-00124	BP5HS	
09482-00128	B6ES	
09482-00129	BP4EY	



SUZUKI	→ NGK	V-Line
09482-00130	BP4EY	
09482-00131	BP5ES	8
09482-00139	BP7ES	
09482-00141	BPR6HS	3
09482-00147	BPR5HS	
09482-00151	B8HS	
09482-00153	B7HS	
09482-00155	BPR5ES	6
09482-00159	BPR4EY	
09482-00163	BP5HS	
09482-00167-000	BPR5EY	9
09482-00167-001	BPR5ES	6
09482-00175	BP8ES	
09482-00177	BP6ES	4
09482-00181	BR10EIX	
09482-00184	D9EA	
09482-00185	D9EA	
09482-00188	BP6HS	18
09482-00189	BP7HS	
09482-00190	B6HS	
09482-00191	B7HS	
09482-00192	B8HS	
09482-00195	B7ES	
09482-00196	B8ES	
09482-00198	B8HS	
09482-00208	BR8EIX	
09482-00209	BR9EIX	
09482-00210	BR10EIX	
09482-00216	BP4EY-11	
09482-00217	BP5EY-11	
09482-00218	BP4EY-11	
09482-00219	BP5EY-11	
09482-00225	B8ES	
09482-00226	BP7ES	
09482-00228	BP5HS	
09482-00229	BPR6HS	3
09482-00237	B8HS	
09482-00239	BPR8ES	
09482-00240-111	BPR8ES	
09482-00244-111	BPR7HS	
09482-00247-111	BR8ES	
09482-00255	BPR7HS	
09482-00259	BP6HS	18
09482-00262	BP5HS-10	
09482-00263	BP5HS-10	
09482-00281	BPR6HS	3
09482-00282	B5HS	
09482-00284	BP6EY-11	
09482-00285	BPR6ES-11	13
09482-00286	BPR6EY-11	10
09482-00287	BP5ES-11	
09482-00288	BP4ES	

SUZUKI	→ NGK	V-Line
09482-00299	BPR6ES	2
09482-00302-111	BPR6HS	3
09482-00303	BP6EY-11	
09482-00305	BP5HS	
09482-00306	BPR6HS	3
09482-00309	B5HS	
09482-00312	BPR5EY-11	
09482-00316	BPR5HS	
09482-00322	BPR5EIX	
09482-00325	BR8EIX	
09482-00348	BR8ES	
09482-00351	B9ES	
09482-00359	BPR5HS	
09482-00362	ZGR5A	15
09482-00363	BPR5EY	9
09482-00368	DCP7E	
09482-00369	DCP7E	
09482-00376	B8HS	
09482-00378	DCPR8E	
09482-00379	DCPR8E	
09482-00381	PJR7A	
09482-00383	DCPR8EIX	
09482-00384	DCPR8EIX	
09482-00385	BP7ES	
09482-00386	DCPR7EIX	
09482-00387	DCPR7EIX	
09482-00392	BP6ES	4
09482-00395	BPR5EY	9
09482-00409	BPR6ES	2
09482-00416-111	BPR5HS	
09482-00419	R2349-11	
09482-00421	BPR6ES-11	13
09482-00426	BK6E	
09482-00427	BKR6E	28
09482-00429	BKR6E	28
09482-00432	BPR5E	6
09482-00433	BPR5EY-11	
09482-00434	BP7ES	
09482-00446	DCPR6E	
09482-00447	DCPR6E	
09482-00448	DCPR7E	
09482-00449	DCPR7E	
09482-00450	DCPR8E	
09482-00452	ZGR5A	15
09482-00454	BPR5EY	9
09482-00468	BPR5E	6
09482-00476	BKR5E	35
09482-00477	BKR5E	35
09482-00479	DCPR7EIX	
09482-00481	DCPR8EIX	
09482-00482	DCPR7EIX	
09482-00484	DCPR8EIX	

SUZUKI	→ NGK	V-Line
09482-00487	BPR6ES	2
09482-00488	DCPR7E	
09482-00493	BPR5E-11	
09482-00494	BKR6E-11	14
09482-00495	BPR7ES	19
09482-00496	BPR5E-11	
09482-00497	BKR5E-11	33
09482-00498	BPR7ES	19
09482-00499	BR8EIX	
09482-00500	BR9EIX	
09482-00501	BPR6EY	
09482-00502	BP5EY	
09482-00504	BPR5EY	9
09482-00508	BKR6E-11	14
09482-00509	R6918B-8	
09482-00511	R6918B-7	
09482-00521	PGR5A	
09482-00525	IKR7A	
09482-00527	KR7AI	
09482-00530	BPR6HS	3
09482-00531	BP6HS	18
09482-00537	DCPR9EIX	
09482-00540	PFR5G-11	
09482-00546	GR5AI-10	
09482-00547	IFR5E11	
09482-00548	IFR6E11	
09482-00549	IFR5J11	
09482-00550	IFR6J11	
09482-00562	IFR5E11	
09482-00566	BKR5E-11	33
09482-00602	IKR6G11	
09482-00603	IKR6G11	
09482-00606	SILFR6A11	
09482-00642	ILZKR7D8	
09482-00647	ILZKR6F11	
09482-69001	BPR6HS	3
09482-M0061-1	IKR6G11	
27117-50000	IRIWAY7	
27118-50000	R7433-8	
27119-00000	IRIMAC9	
94820-01197	B9ES	
94820-0550	IFR6J11	
99000-69257-001	R2525-10	
99000-69835-B6R	BR6HIX	
99000-69835-B7R	BR7HIX	
99000-69835-B8R	BR8HIX	
99000-69835-BP6	BPR6HIX	
99000-69835-BP7	BPR7HIX	
99000-69835-BR1	BR10EIX	
99000-69835-BR8	BR8EIX	
99000-69835-BR9	BR9EIX	
99000-69835-CR8	CR8EIX	

SUZUKI	→ NGK	V-Line
99000-69835-DR8	DR8EIX	
99000-69835-DR9	DR9EIX	
99000-79A37-16E	BPR5EIX	
99000-79A37-20F	BR6HIX	
99000-79A37-22E	BR7EIX	
99000-79A37-24E	BR8EIX	
99000-79A37-24R	BR8EIX	
99000-79A37-27R	BR9EIX	
99000-79A37-29E	BR10EIX	
99000-79A37-31E	BR10EIX	
99000-79A37-K0P	BKR6EIX-11	
99000-79A37-W6X	BPR5EIX	
99000-79A45-B0E	BR10EIX	
99000-79A45-B6H	BR6HIX	
99000-79A45-B7E	BR7EIX	
99000-79A45-B7H	BR7HIX	
99000-79A45-B8E	BR8EIX	
99000-79A45-B8H	BR8HIX	
99000-79A45-B9E	BR9EIX	
99000-79A45-P8E	BPR8EIX	
99000-79B56	BPR4EY-11	
99000-79J80-K16	BKR5EIX-11	
99000-79J80-K20	BKR6EIX-11	
99000-79J80-U22	DCPR7EIX	
99000-79J80-W16	BPR5EIX-11	
99000-79J80-W20	BPR6EIX-11	
99000-79J80-W22	BPR7EIX	
99000-79K24-H27	CR9EHIX-9	
99000-79K24-IW4	BR8EIX	
99000-79K24-IW7	BR9EIX	
99000-79K24-U24	CR8EIX	
99000-79K24-W22	BR7HIX	
99000-79K24-W24	BR8HIX	
99000-79K24-W31	BR10EIX	
99000-79K24-X24	DR8EIX	
99000-79K24-X27	DR9EIX	
99000-79K60-BP6	BPR6EIX-11	
99000-79K60-DC7	DCPR7EIX	
99000-79K60-K5R	BKR5EIX	
99000-79K60-K6R	BKR6EIX	
99000-79K60-KR6	BKR6EIX-11	
99000-79K60-P5R	BPR5EIX	
99000-79K60-P6R	BPR6EIX	
99000-79K60-P7R	BPR7EIX	
99000-79K60-PR5	BPR5EIX-11	
99000-79K73-K16	BKR5EIX-11P	
99000-79K73-K20	BKR6EIX-11P	
99000-79K73-U22	DCPR7EIX-P	
99000-79L65-001	BKR6EIX-11P	
99000-79L65-002	BKR5EIX-P	
99000-79L65-003	BKR6EIX-P	
99000-79L65-004	DCPR7EIX-P	

SUZUKI	→ NGK	V-Line
99000-79L65-005	BKR5EIX-11P	
99000-79L65-006	BKR7EIX-P	
TOYOTA	→ NGK	V-Line
90919-01265	DIFR5C	
04195-34140	BP5ES	8
04195-34150	BP6ES	4
04195-34280	BPR5EY	9
04195-34320	BPR5EY-11	
08922-01016-83	BPR5EY	9
08922-01017-83	BPR6EY-11	10
08922-01019-83	BPR5EY-11	
08922-01020-83	BCPR6EY-11	
90048-51054	BPR5EY	9
90048-51059	BPR6EY	
90048-51063	BPR5EY-11	
90048-51093-A	BPR5EY-11	
90048-51126	BPR5EJ	
90048-51134	BCPR6EKD	
90048-51134-1	BCPR6EKD	
90048-51158	BKR5E-11	33
90048-51187	IKR7C	
90080-91116	BKR6EKPB-11	
90098-14395	BP4EY	
90098-14425	BPR4EY	
90098-14545	BPR4ES-13	
90098-14595	BP4EY	
90098-14615	BP4EY-11	
90098-14665	BPR4EY-11	
90098-14715	B-4	
90098-14785	BPR4FS	
90098-14805	BPR4FS-15	
90098-16145	AP5FS	
90098-16325	BPR5ES	6
90098-16395	BP5EY	
90098-16425	BPR5EY	9
90098-16455	B5ES	
90098-16505	B5ES	
90098-16515	BP5HS	
90098-16545	BP5ES-13	
90098-16595	BP5EY	
90098-16615	BP5EY-11	
90098-16635	BP5EFS	
90098-16645	B5ES	
90098-16655	BUR5EB-11	
90098-16675	BPR5EY	9
90098-16695	BP5EY	
90098-16705	BP5FS	
90098-16735	APR5FS	
90098-16745	BPR5E	6
90098-16795	BPR5FS-11	
90098-16805	BPR5FS-15	
90098-16875	YR55IX	

TOYOTA	→ NGK	V-Line
90098-16895	BPR6EFS	7
90098-16925	BP5HS-10	
90098-16935	BR5ES	
90098-16955	BE527Y-11	
90098-16975	BUR5EB-11	
90098-16985	BCPR5EY-11	
90098-17015	AB-6	
90098-17025	AB-6	
90098-20145	AP6FS	
90098-20276	B6S	
90098-20325	BPR6ES	2
90098-20395	BP6EY	
90098-20425	BPR6EY	
90098-20455	B6ES	
90098-20505	B6ES	
90098-20515	BP6HS	18
90098-20545	BPR6EIX-11	
90098-20595	BP6EY	
90098-20615	BP6EY-11	
90098-20625	BPR6EK-A	
90098-20635	BP6EFS	5
90098-20645	B6HS	
90098-20655	BUR6EB-11	
90098-20665	BPR6EY-11	10
90098-20675	BPR6EY	
90098-20695	BP6ES	4
90098-20705	BP6FS	
90098-20735	APR6FS	
90098-20745	BPR6ES	2
90098-20755	BUR6EA-11	
90098-20785	BPR6FS	
90098-20885	BP6EFS	5
90098-20895	BPR6EFS	7
90098-20905	BR6ES	
90098-20915	BUR6EB-11	
90098-20935	BR6ES	
90098-20975	BUR6EB-11	
90098-20985	BCPR6EY-11	
90098-22015	AB-7	
90098-22025	AB-7	
90098-22276	B7S	
90098-22325	BPR7ES	19
90098-22455	B7ES	
90098-22505	B7ES	
90098-22515	BP7HS	
90098-22595	BP7EY	
90098-22645	B7HS	
90098-22655	BUR7EB-11	
90098-22745	BPR7ES	19
90098-22755	BUR7EA-11	
90098-22885	BP7EFS	
90098-22905	BR7ES	

TOYOTA	→ NGK	V-Line
90098-22915	BUR7EB-11	
90098-22935	BR7ES	
90098-22975	BUR7EB-11	
90098-24125	BP8ES	
90098-24276	B8S	
90098-24505	B8ES	
90098-24645	B8HS	
90098-24695	BP8ES	
90098-24935	BR8ES	
90098-25305	B8EG	
90098-25375	BR8HIX	
90098-27465	D9EA	
90098-27505	B9ES	
90098-27645	B9HS	
90098-33034	BCPR5EY-11	
90098-64018	B-4L	
90098-64032	GR4IX	
90098-64033	GR4IX	
90098-64050	BPR4ES-13	
90098-64065	ZFR4F-11	
90098-64066	ZFR4F-11	
90098-66001	BP5EY-11	
90098-66004	BPR5E-11	
90098-66005	BCPR5EY-11	
90098-66006	BUR5EB-11	
90098-66007	BP5EY-11	
90098-66016	B-6L	
90098-66031	BPR5EY-11	
90098-66032	BPR5EIX	
90098-66033	BPR5EIX	
90098-66038	BCPR5EIX-11	
90098-66039	BCPR5EIX-11	
90098-66040	BCPR5EY-11	
90098-66045	BCPR5EIX-11	
90098-66047	BKR5E-11	33
90098-66050	BPR5ES-13	
90098-66053	BKR5E	35
90098-66054	BKR5EIX-11	
90098-66056	BKR5EYA-11	39
90098-66058	BPR5E	6
90098-66059	BKR5E-N-11	
90098-66064	PFR5J-11	
90098-66065	ZFR5J-11	
90098-66066	ZFR5F-11	40
90098-66070	PFR5B-11	
90098-66071	BKR5EYA	
90098-66075	ZFR5E-11	
90098-66077	BKR5EIX-11	
90098-66080	PZFR5F-11	
90098-66081	PZFR5F	
90098-66082	BCPR5E	32
90098-66108	PGR5A-11	

TOYOTA	→ NGK	V-Line
90098-66109	BPR5EJ	
90098-66113	PTR5C-13	
90098-66114	BKR5EIX-11	
90098-66115	BCPR5EIX-11	
90098-66116	BPR5EIX-11	
90098-70001	BP6ES-11	
90098-70002	BUR6EA-11	
90098-70003	BPR6ES-11	13
90098-70004	BPR6ES-11	13
90098-70005	BKR6E-11	14
90098-70007	BP6ES-11	
90098-70027	AR6FS	
90098-70031	BPR6EY-11	10
90098-70032	BPR6EIX	
90098-70033	BPR6EIX	
90098-70034	BCPR6EY-11	
90098-70038	BCPR6EIX-11	
90098-70039	BCPR6EIX-11	
90098-70040	BKR6E-11	14
90098-70041	ZFR6A-11	
90098-70043	BP6ES	4
90098-70044	ZFR6A-11	
90098-70046	BCPR6EIX-11	
90098-70047	BKR6E-11	14
90098-70048	BPR6EKN	
90098-70050	BPR6EIX-11	
90098-70051	DCPR6E	
90098-70053	BKR6E	28
90098-70054	BKR6EIX-11	
90098-70056	BKR6EYA-11	
90098-70058	BPR6ES	2
90098-70059	BKR6E-N-11	
90098-70060	PFR6G-11	
90098-70064	PFR6J-11	
90098-70065	ZFR6J-11	
90098-70066	ZFR6F-11	
90098-70067	BCPR6EKD	
90098-70070	PFR6B-11	
90098-70071	BKR6EYA	
90098-70074	ZFR6G	
90098-70077	BKR6EIX-11	
90098-70080	PZFR6F-11	
90098-70081	PZFR6F	
90098-70082	BCPR6E	12
90098-70085	BUR6ET	1
90098-70086	PFR6J	
90098-70105	BPR6EKN	
90098-70108	PGR6A-11	
90098-70114	BKR6EIX-11	
90098-70115	BCPR6EIX-11	
90098-70116	BPR6EIX-11	
90098-72019	DPR7Z	

TOYOTA	→ NGK	V-Line
90098-72024	BR7HS	
90098-72036	BR7EIX	
90098-72042	DCP7E	
90098-72047	BKR7E-11	
90098-72051	DCPR7E	
90098-72052	DCPR7EIX	
90098-72070	PFR7B-11	
90098-72078	BK7EK-N-11	
90098-72114	IRIWAY7	
90098-72115	IRITOP7	
90098-72116	BPR7EIX	
90098-74013	B8EG	
90098-74036	BR8EIX	
90098-74037	DR8EIX	
90098-74051	DCPR8E	
90098-74052	DCPR8EIX	
90098-77036	BR9EIX	
90098-77037	DR9EIX	
90098-77111	CR9EHIX-9	
90098-79036	BR10EIX	
90098-79037	DR9EIX	
90098-81036	BR10EIX	
90098-99201	BCPR6EP-11	
90098-99202	BCPR5EIX-11	
90098-99203	BPR5EP-11	
90098-99204	BCPR6EP-N-8	
90098-99205	BKR6EP-11	
90098-99206	BKR6EP-N-8	
90098-99207	BKR5EP-11	
90098-99208	BKR6EKPB-11	
90919-01051	BPR5ES	6
90919-01056	BP4EY	
90919-01059	BP5EY	
90919-01061	BP5EY	
90919-01063	BPR6EK-A	
90919-01064	BPR5EY	9
90919-01065	BPR5EY	9
90919-01073	B5ES	
90919-01083	BP6EY	
90919-01084	BPR6EY	
90919-01085	BP4EY-11	
90919-01087	BPR5EIX-11	
90919-01088	BPR6EK-A	
90919-01089	BPR6EK-A	
90919-01091	BPR5EY	9
90919-01092	BPR6EK-A	
90919-01094	BP5EY-11	
90919-01095	BPR5EIX-11	
90919-01096	BPR5EIX-11	
90919-01097	BPR6EK-A	
90919-01098	BPR6EY	
90919-01099	BP4EY	

TOYOTA	→ NGK	V-Line
90919-01100	BP5EFS	
90919-01101	BP5EY	
90919-01102	BPR5EY	9
90919-01103	BPR4EY	
90919-01104	BPR5EY-11	
90919-01108	BPR4EY-11	
90919-01109	BPR4EY-11	
90919-01113	BRE527Y-11	
90919-01114	BRE527Y-11	
90919-01115	BPR5EP-11	
90919-01116	BPR5EP-11	
90919-01117	BE529Y-11	
90919-01118	BE529Y-11	
90919-01119	BRE529Y	
90919-01120	BRE529Y	
90919-01121	BCPR5EIX-11	
90919-01122	BCPR5EIX-11	
90919-01123	BRE529Y-11	
90919-01125	BPR6EY-11	10
90919-01126	BPR6EY-11	10
90919-01127	BCPR6EP-11	
90919-01128	BCPR6EP-11	
90919-01129	BCPR5EY-11	
90919-01130	BCPR5EY-11	
90919-01131	BCPR6EY-11	
90919-01132	BCPR6EY-11	
90919-01133	BPR5EP-11	
90919-01134	BPR5EP-11	
90919-01135	BCPR6EIX-11	
90919-01136	BCPR6EIX-11	
90919-01138	BP6EY	
90919-01139	BP6EY-11	
90919-01143	BPR5EP-11	
90919-01144	BPR5EP-11	
90919-01145	BCPR6EP-N-8	
90919-01146	BCPR6EP-N-8	
90919-01147	BPR6EP-8	
90919-01148	BPR6EP-8	
90919-01149	BCPR6EY	
90919-01150	BCPR6EY	
90919-01151	BCPR5EP-8	
90919-01152	BCPR5EP-8	
90919-01153	BCPR5EY-11	
90919-01154	BCPR5EY	
90919-01155	BCRE527Y	
90919-01156	BCRE527Y	
90919-01157	BCPR6EIX-11	
90919-01158	BCPR5EIX-11	
90919-01159	BCPR5EY-11	
90919-01164	BKR5EYA-11	39
90919-01165	BKR5EYA-11	39
90919-01166	BKR6EYA-11	

TOYOTA	→ NGK	V-Line
90919-01167	BKR6EYA	
90919-01168	BKR5EP-11	
90919-01169	BKR5EP-11	
90919-01170	BCPR4EY-11	
90919-01172	BKR6EP-N-8	
90919-01173	BKR6EP-N-8	
90919-01176	BKR5EYA	
90919-01177	BKR5EYA	
90919-01178	BKR6EP-11	
90919-01179	BKR6EP-11	
90919-01180	BKR6EP-8	
90919-01181	BKR6EP-8	
90919-01182	BCPR6EIX-11	
90919-01184	BKR6EY-11	
90919-01185	BKR6EYA-11	
90919-01187	BKR6EP-13	
90919-01188	BKR6EP-13	
90919-01191	ILFR6T11	
90919-01192	BKR5EKB-11	
90919-01193	BKR5EKB-11	
90919-01194	BKR6EKPB-11	
90919-01195	BKR6EKPB-11	
90919-01196	BKR5EKPB-11	
90919-01197	BKR5EKPB-11	
90919-01198	BKR6EKB-11	
90919-01201	BKR5EKPB-13	
90919-01202	BKR6EKB-11	
90919-01205	BKR5EIX-P	
90919-01206	BKR5EIX-P	
90919-01207	BKR6EIX-11P	
90919-01208	BKR6EPA-8	
90919-01209	BKR5EIX-11P	
90919-01210	IFR6T11	
90919-01211	IFR6T11	
90919-01213	BKR6EPA-8	
90919-01214	BKR5EIX-P	
90919-01218	IFR5T11	
90919-01219	BKR5EIX-11P	
90919-01220	BKR6EP-11	
90919-01221	HB6AIX-11P	
90919-01225	BKR6EIX-11P	
90919-01226	HB6BIX-11P	
90919-01230	HB6BIX-11P	
90919-01233	ILFR5T11	
90919-01234	ILFR5T11	
90919-01235	LFR6C-11	48
90919-01236	LFR6C-11	48
90919-01237	IFR6T11	
90919-01238	IFR6T11	
90919-01242	BKR5EYA-11	39
90919-01244	BKR5EYA	
90919-01245	BKR5EYA	

TOYOTA	→ NGK	V-Line
90919-01247	DILFR6D11	
90919-01249	DFH6B-11A	
90919-01253	ILKAR7B11	
90919-01275	DF6H-11B	
90919-W1007	DF6H-11B	
90919-YZZAA	BCP5E	16
90919-YZZAB	BCP6E	17
90919-YZZAC	BKR6E-11	14
90919-YZZAD	BKR5EYA	
90919-YZZAE	BKR5EYA-11	39
90919-YZZAF	BKR6EYA	
90919-YZZAG	BKR6EYA-11	
90999-09006	BP5EY	
90999-09007	BP6EY	
99098-22695	BP7ES	
VOLVO	→ NGK	V-Line
1150 278	IFR6B11	
1367 528	BPR6ES	2
1367 529	BPR6ES	2
22401 AA670	IFR6B11	
2707 46	BPR6ES	2
2712 39	IZFR6B	
2716 03	BKR6E	28
2717 27	BKR6E	28
3063 7308	PFR6B	
3063 7308 791	PFR6B	
3063 7308 887	PFR6B	
3063 7385	LFR6D	
3063 7385 496 A	LFR6D	
3065 0843	LFR6D	
3071 3859	LFR6D	
3073 1383	IFR6B11	
3073 1425	TR5B-13	45
3073 1878	TR6AP-13	
3075 1468 889	ILFR6B	
3075 1469	LFR6D	
3075 1805	ILFR6B	
3075 1806	ILFR6B	
3075 8130	ILTR6G8G	
3077 7349	TR6AP-13	
3121 6183	ILFR6B	
3121 6184	ILFR6B	
3121 6297	ITR6F13	
3121 6525	ITR6F13	
3121 6674	ILFR6K8	
3127 2399	ILFR6K8	
3128 6359	DILFR6A11	
3133 0450	ILZTR6A8G	
3517 980	BKR6ES	28
3650 843	LFR6D	
8642 660	BKR6ETUC	
8642 661	BKR6EQUA	

VOLVO	→ NGK	V-Line
8670 058	BKR6EIX	
8687 990 H 939	IFR6B11	
8692 070	PFR6B	
8692 071	PFR6B	
8692 072	PFR6B	
8694 749	ITR6F13	
9146 775	BKR6ETUC	
9146 7759 01	BKR6EQUA	
9146 7759 07	BKR6EQUA	
VW Group	→ NGK	V-Line
03C 905 601 A	SIZFR6B8EG	
03C 905 601 B	SIZFR6B8EG	
03F 905 600 A	IZFR6P7	
03H 905 600	ILZKR8A8DE	
04C 905 606	ZKER6A-10EG	
04C 905 606 A	ZKER6A-10EG	
04E 905 601	PZKER7B8EGS	55
04E 905 601B	PZKER7B8EGS	55
04E 905 602	PKER7A8EGS	
04E 905 602 A	PKER7A8DES	
04E 905 602 D	IKER7A8EGS	
04E 905 612	PZKER7B8EGS	55
06E 905 611	PFR6X-11	
06H 905 601 A	PFR7S8EG	50
06K 905 601 B	PLFER7A8EG	
06K 905 601 M	SILFER8C7ES	
06K 905 611 C	PLFER7A8EG	
06M 905 606 F	SILKGR9A7ES	
079 905 626 M	SILFER8C7ES	
101 000 000 AB	BP6ESZ	
101 000 001 AB	BUR6ET	1
101 000 001 AC	BUR6ET	1
101 000 001 AD	BP5ET-10	
101 000 001 AE	BP5ET	
101 000 002 AB	BP6ESZ	
101 000 003 AA	BCP7ET	
101 000 004 AA	BCP7ET	
101 000 005 AA	BUR6ET	1
101 000 005 AB	BUR6ET	1
101 000 005 AC	BP7ET	
101 000 005 AD	BP5ET-10	
101 000 005 AE	BP5ET	
101 000 005 AF	BP5ET	
101 000 006 AB	BP6ESZ	
101 000 006 AC	BP6ESZ	
101 000 007 AA	BUR6ET	1
101 000 007 AB	BUR6ET	1
101 000 007 AC	BP5ET-10	
101 000 007 AD	BUR6ET	1
101 000 016 AA	PFR7B	
101 000 016 AB	PFR6Q	37
101 000 017 AA	BCP7ET	

VW Group	→ NGK	V-Line
101 000 026 AA	BUR5ET	22
101 000 026 AB	BUR6ET	1
101 000 027 AA	BUR6ET	1
101 000 027 AB	BP5ET	
101 000 027 AC	BP5ET-10	
101 000 028 AA	BCP7ET	
101 000 029 AA	BU6EFSZ	
101 000 029 AB	BUR6EFSZ	
101 000 033 AA	BKUR6ET-10	24
101 000 033 AB	BKUR7ET	
101 000 033 AC	BKUR5ET	29
101 000 033 AF	BKUR6ET	27
101 000 033 AG	BKUR5ET-10	
101 000 034 AA	BP6ESZ	
101 000 035 AA	BKR5EKU	
101 000 035 AB	BKR5EKU	
101 000 035 AE	BKR7EKU	
101 000 035 AF	BKR7EKU	
101 000 035 AH	BKR5EKUP	
101 000 035 HJ	BKR6EKUB	
101 000 036 AA	BUR6ET	1
101 000 036 AB	BUR5ET	22
101 000 036 AC	BUR5ET-10	21
101 000 038 AA	BPR5EKU	
101 000 038 AB	BPR5EKU	
101 000 039 AA	BPR5EKU	
101 000 039 AB	BPR5EKU	
101 000 040 AC	BUR5ET	22
101 000 040 AD	BUR6ET	1
101 000 040 AE	BUR5ET-10	21
101 000 041 AC	BKUR6ET-10	24
101 000 041 AD	BKUR6ET	27
101 000 041 AE	BKUR7ET	
101 000 047 AA	BP5ES-A	
101 000 047 AB	PGR6D	
101 000 048 AA	BP5HS	
101 000 049 AD	BKR6ETA-10	
101 000 050 AA	BUR5ET	22
101 000 050 AB	BUR5ET-10	21
101 000 050 AC	BUR6ET	1
101 000 051 AA	BKUR6ET-10	24
101 000 051 AB	BKUR7ET	
101 000 052 AA	BUR6EFSZ	
101 000 055 AA	BKR6EK	20
101 000 060 AA	BKUR5ET-10	
101 000 062 AA	PZFR6J-11	
101 000 062 AB	PZFR5D-11	34
101 000 063 AA	PFR6Q	37
101 000 063 AC	PFR7Q	
101 000 065 AA	BKR6ETA-10	
101 100 068 AA	ZFR6S-Q	
101 905 600	PZFR5J-11	



VW Group	→ NGK	V-Line
101 905 600 A	PZFR6J-11	
101 905 600 R1	PZFR5J-11	
101 905 601 F	ZFR6T-11G	44
101 905 602	KR8BI	
101 905 606	IZKR7B	
101 905 606 A	IZKR7B	
101 905 607	BKR6EKUE	
101 905 611	PFR6U-11G	
101 905 611 A	PFR6X-11	
101 905 611 C	PFR7G	
101 905 611 G	PFR8S8EG	
101 905 615 A	BKR6EQUA	
101 905 616	BKR6EQUA	
101 905 617	ZFR5P-G	41
101 905 617 C	ZFR6T-11G	44
101 905 617 R1	ZFR5P-G	41
101 905 618 A	ZFR6T-11G	44
101 905 621	PFR7W-T	
101 905 621 B	PFR6W-TG	
101 905 621 C	PFR7W-TG	
101 905 622	ILZKR7A	
101 905 622 A	ILZKR8A	
101 905 626	PZFR6R	52
101 905 626 A	SIZFR6A6D	
101 905 631 G	PFR8S8EG	
101 905 631 H	PFR7S8EG	50
325 86	ZFR6S-Q	
400 905 619	PFR7G	
410 905 619	KR8BI	
9A7 905 601 50	SILKGR9A7ES	
N 017 8011	B5HS	
05E 905 602	ILKER7A8EGS	
05E 905 602 A	ILKER7B8DES	

BMW	→ NGK	D-Power
12 23 1 288 245	Y-924J	1
12 23 2 241 389	Y-924J	1
12 23 2 248 059	Y-507J	32
12 23 7 786 869	Y-547AS	47
12 23 7 798 001	Y1039AS	80
CHRYSLER	→ NGK	D-Power
05066 840 AA	Y1031J	71
5175 756 AA	Y8002AS	51
68029497 AA	Y8011AS	
DAIHATSU	→ NGK	D-Power
19850-54050-000	Y-118R	
19850-54071-000	Y-146R	
19850-54090-000	Y-715R	
19850-56010-000	Y-178	
19850-56012-000	Y-178T	
19850-58030-000	Y-128T	
19850-58040-000	Y-178T	
19850-64010-000	Y-146R	
19850-64020-000	Y-703R	
19850-68010-000	Y-147T	
19850-68040-000	Y-178T	
19850-68060-000	Y-197R	
19850-87309-000	Y-128T	
19850-87701-000	Y-146R	
19850-87702-000	Y-703R	
FIAT Group	→ NGK	D-Power
46 44 76 10	Y-928U	29
46 45 19 51	Y-747U	26
46 75 17 64	Y-939J	43
46 75 41 54	Y-534J	36
46 79 23 55	YE07	
46 79 23 59	YE07	
46 79 60 50	Y8003J	62
50 03 16 493	Y-502R	
50 03 51 992	Y8005J	64
55 18 78 63	YE07	
55 20 07 55	Y9003AS	78
55 20 08 17	Y1030J	70
55 21 00 51	Y9001AS	72
55 23 84 04	Y9001AS	72
60 50 71 23	Y-909R	
60 81 22 92	Y-924J	1
60 81 46 13	Y-747U	26
71 71 90 15	Y-924J	1
76 32 58 7	Y-739R	
77 35 92 0	Y-924J	1
96 33 21 43 80	Y-924J	1
96 38 98 59 80	Y-504J	24
96 51 02 97 80	Y-504J	24
96 51 58 36	Y1005J	56
96 51 58 36 80	Y1005J	56
96 52 54 82 80	YE08	

FIAT Group	→ NGK	D-Power
96 59 27 92 80	Y-548J	75
98 46 24 92	Y-926U	
FORD	→ NGK	D-Power
1148 105	YE04	40
1313 809	Y1005J	56
1369 590	YE05	73
1427 905	YE08	
1447 128	YE05	73
1459 460	Y-548J	75
1473 356	Y1005J	56
1525 910	YE04	40
1542 845	Y8003J	62
1682 276	Y8001AS	58
4025 139	Y-701J	39
1449686	Y-526J1	69
1717 631	Y1045AS	89
2191043	Y8012AS	
2S6Q-6M090-AA	YE04	40
2S6Q-6M090-AB	YE04	40
2S6Q-6M090-BA	YE05	73
2S6Q-6M090-BB	YE05	73
3M5Q-6M090-AB	Y1005J	56
3M5Q-6M090-AC	Y1005J	56
6G9Q-6M090-AA	YE08	
6M34-12A342-AA	Y-526J1	69
7C16-6M090-AA	Y-548J	75
9S51-6M090-AA	Y8003J	62
AV6Q-6M090-BA	Y8001AS	58
BK3Q-6M090-AB	Y1045AS	89
BS51-6M090-AA	Y9001AS	72
JX6Q 6M090 AA	Y8012AS	
JX6Q-6M090-AA	Y8012AS	
XM341-2A342-BA	Y-701J	39
GM	→ NGK	D-Power
1 214 034	YE07	
443 50 91	CZ167	91
4 805 511	Y8009AS	
93 198 468	CZ167	91
12 14 305	Y-523J	37
12 14 457	Y-748U	14
44 03 145	Y-910J	3
12 14 028	CZ24	
12 14 036	CZ24	
12 14 079	CZ24	
12 625 507	Y8011AS	
25 181 860	Y8010AS	
4802239	Y8010AS	
55 23 84 04	Y9001AS	72
55 564 219	Y9004AS	
55 664 219	Y9001AS	72
91 11 145	Y-910J	3
91 18 201	Y-748U	14

GM	→ NGK	D-Power
91 96 669	Y-523J	37
93 178 411	YE07	
93 190 433	Y1030J	70
93 191 771	Y9003AS	78
94 133 759	Y-904M1	
94 439 218	Y-306R	
95 50 84 92	CZ24	
96 440 144	Y8009AS	
97 080 554	Y-603J	60
97 12 76 46	CZ24	
97 35 72 90	CZ24	
HINO	→ NGK	D-Power
19110-1040	Y-176	
1985A-56010	Y-178	
1985A-56012	Y-178T	
1985A-56022	Y-128T	
1985A-68060	Y-197R	
60543-30901	Y-173	
63013-30010	Y-176	
HONDA	→ NGK	D-Power
12291R-BDE01	CZ274	
12291R-LOG01	CZ274	
HYUNDAI/KIA	→ NGK	D-Power
OK04S-18140-A	Y-721J	
OK054-18140	Y-701J	39
OK75A-18140	Y-701J	39
36710-27000	Y-749J	
36710-27010	Y-749J	
36710-2A100	Y-527J	67
36710-2A200	Y-527J	67
36710-2A700	CZ203	68
36710-2F000	CZ105	
36710-2F100	Y1003AS	
36710-42000	Y-722JS	
36710-42020	Y-722JS	
36710-42021	Y-722JS	
36710-42500	CZ257	83
36710-42510	CZ257	83
36710-4A000	Y-508J	
36710-4A100	Y-508J	
36710-4X900	Y-535J	
ISUZU	→ NGK	D-Power
9417-5158	Y-904M1	
5-8610-1642-0	CZ261	
5-8610-1643-0	Y-712RS	
5-8610-1644-0	Y-707RS	
5-8611-5977-0	Y-757RS	
8-8440-2303-1	Y-711J	28
8-9417-5158-0	Y-904M1	
8-9417-5158-1	Y-904M1	
8-9417-5158-2	Y-904M1	
8-9431-9700-1	Y-710J	

ISUZU	→ NGK	D-Power
8-9431-9700-2	Y-710J	
8-9431-9700-4	Y-710J	
8-94390777	Y-784M1	
8-9439-0777-2	Y-784M1	
8-9439 0777-6	Y-784M1	
8-9708-0554-0	Y-603J	60
8-9708-0554-1	Y-603J	60
8-9710-6549-1	Y-720U1	
8-9710-6549-4	Y-720U1	
8-9714-3674-1	Y1038J	
8-9735-7290-0	CZ24	
8-9801-3392-0	Y1001J1	
8-9817-4898-0	Y1001J1	
9-8251-1945-0	Y-874-1	
9-8251-1978-0	Y-104	
9-8251-1978-1	Y-104	
9-8251-1994-0	Y-874-1	
9-8251-3928-2	Y-271-2	
IVECO	→ NGK	D-Power
50 03 51 992	Y8005J	64
JEEP	→ NGK	D-Power
050 66 840 AA	Y1031J	71
517 57 56 AA	Y8002AS	51
680 29 497 AA	Y8011AS	
682 86 210 AA	CZ553	
LAND ROVER	→ NGK	D-Power
ERR 6066	Y-605J	
ETC 8847	Y-729U	34
LR 001 302	YE08	
LR 073727	CZ552	
MAZDA	→ NGK	D-Power
1353-18-140	Y-107T	
1353-18-140A	Y-107T	
1N01-18-601A	CZ259	
1N02-18-601	CZ260	
R2L2-18-601	Y-721RS	
RF2A-18-601	Y-529J	
RFG1-18-601	Y-701J	39
RFJ5-18-601	Y-701J	39
RFS5-18-601	Y1006J	
RFS5-18-601A	Y1006J	
S201-18-140	Y-107R	
S210-18-140	Y-701J	39
S501-18-140A	Y-107R	
S550-18-601	CZ165	87
SE01-18-140A	Y-157R	
SEM1-18-601	Y-771R	
SH01-18-601A	CZ163	82
VS01-18-601	Y-721RS	
WE01-18-601	Y-526J1	69
WL03-18-601	Y-701J	39
WL81-18-601	Y-701J	39



MAZDA	→ NGK	D-Power
WLE7-18-601	CZ262	
WLE8-18-601	CZ262	
WLY7-18-601	CZ262	
WLY8-18-601	CZ262	
Y701-18-601	Y-603J	60
MERCEDES	→ NGK	D-Power
A 000 159 81 01	Y-924J	1
A 001 159 15 01	Y-930U	30
A 001 159 20 01	Y-925J	16
A 001 159 21 01	Y-925J	16
A 001 159 26 01	Y-929U	41
A 001 159 27 01	Y-746J	38
A 001 159 28 01	Y-745U	11
A 001 159 35 01	Y-924J	1
A 001 159 36 01	Y-916J	6
A 001 159 37 01	Y-745U	11
A 001 159 38 01	Y-745U	11
A 001 159 42 01	Y-745U	11
A 001 159 46 10	YE13	
A 001 159 48 01	Y-745U	11
A 001 159 49 01	Y-745U	11
A 001 159 50 01	Y8002AS	51
A 001 159 56 01	CZ106	53
A 001 159 57 01	CZ303	54
A 001 159 58 01	CZ106	53
A 001 159 65 01	CZ554	
A 001 159 66 01	CZ303	54
A 001 159 68 01	CZ106	53
A 001 159 73 01	CZ551	85
A 001 159 80 01	CZ551	85
A 415 159 00 01	Y1035AS	77
A 622 159 00 01	Y1010AS	88
A 642 159 01 01	CZ159	84
A 660 159 02 01	Y-543J	46
A 660 159 04 01	CZ158	
A 665 159 02 01	Y-536J	81
A 667 159 00 01	Y-537AS	
C0 004 562 V003	Y-543J	46
Q0 004 562 V003 00 0000	Y-543J	46
MAZDA	→ NGK	D-Power
1820-A009	CZ251	76
1820-A019	CZ267	90
1820-A020	CZ271	
30L66-00300	Y-723R	
30L66-00301	Y-723R	
30L66-00302	Y-723R	
30L66-00400	Y-723U	
30L66-00400-9V	Y-723U	
30L66-00401	Y-723U	
30L66-00402	Y-723U	
31A66-03100	Y-701U	
31A66-03101	Y-701U	

MITSUBISHI	→ NGK	D-Power
31A66-03102	Y-701U	
32A66-07010	Y-904M1	
32A66-07100	Y-904M1	
32C98-55808	Y-722JS	
34466-21300	Y-182T	
34466-21301	Y-182T	
34466-31301	Y-182T1	
36710-42500	CZ257	83
91304-04300	Y-701J	39
EE 960 01	Y-173	
EE 960 02	Y-104	
M 816 732	Y-933J	25
MD 014 997	Y-115R1	
MD 050 212	Y-115T1	
MD 077 167	Y-707RS	
MD 197 511	CZ257	83
MD 301 950	Y-733J	13
MD 344 469	Y-733J	13
ME 017 010	Y-274	
ME 017 013	Y-274	
ME 017 057	Y-971M	
ME 200 970	CZ256	
ME 201 638	CZ256	
ME 203 539	Y1007J	59
ME 203 754	CZ256	
MM 431 439 01	Y-142T	
MM 432 148	Y-145T	
MN 960 270	YE13	
MN 960 296	YE13	
MN 980 234	YE14	48
MN 980 406	CZ304	55
MR 577 131	Y-733J	13
NISSAN	→ NGK	D-Power
11065-00Q0A	Y-517J	66
11065-00Q0C	CZ167	91
11065-00Q0E	Y1035AS	77
11065-00Q0H	Y1010AS	88
11065-00Q0K	Y1047AS	
11065-00Q0L	Y1010AS	88
11065-00QAG	Y-732J	4
11065-02T00	Y-955RS	
11065-0W801	CZ261	
11065-10G00	Y-705RS	
11065-10T01	Y-757RS	
11065-16A05	Y-117RS	
11065-16A15	Y-117RS	
11065-1749R	Y1010AS	88
11065-2TB0A	Y-519J	61
11065-2W202	CZ258	
11065-31N00	Y-712RS	
11065-31W02	Y-112TS	
11065-34W00	Y-112M1	



NISSAN	→ NGK	D-Power
11065-37506	Y-103	
11065-37507	Y-103	
11065-43G01	Y-707RS	
11065-57J00	CZ260	
11065-5C900	CZ260	
11065-63G00-GW	Y-707RS	
11065-65N01	CZ261	
11065-7C000	Y-530J	
11065-89T0B	Y-784M1	
11065-89TA6	Y-784M1	
11065-89TA8	Y-784M1	
11065-89TB0	Y-784M1	
11065-9C600	Y-712RS	
11065-AD200	Y-519J	61
11065-AD201	Y-519J	61
11065-AD220	Y-519J	61
11065-C8600	Y-755RS	
11065-DB000	Y-522J	
11065-G2400	Y-712RS	
11065-G2460	Y-712RS	
11065-G5501	CZ259	
11065-HC200	Y-701J	39
11065-HC251	Y-721RS	
11065-J5570	Y-222T	
11065-MA70A	Y-538J	
11065-MA70A-SG	Y-538J	
11065-OW801	CZ261	
11065-T3470	Y-181T	
11065-T8200	Y-112R1	
11065-T8201	Y-162R1	
11065-T8202	Y-112R1	
11065-T8203	Y-162R1	
11065-T9000	Y-272R1	
11065-T9001	Y-272R1	
11065-V7202	CX51	
11065-V7203	CZ166	
11065-W2500	Y-204RS	
11065-W2510	Y-204RS	
11065-Y1402	Y-103-2	
11065-Y1403	Y-103-2	
11065-Y1404	Y-103-2	
RFJ5-18-601	Y-701J	39
OPEL	→ NGK	D-Power
12 14 032	Y8003J	62
12 14 034	YE07	
12 14 040	Y-534J	36
12 14 063	Y-541J	42
12 14 106	Y9001AS	72
12 14 300	Y-810	
12 14 301	Y-541J	42
12 14 304	Y-208T	
12 14 308	Y-306R	

OPEL	→ NGK	D-Power
12 14 310	Y-719RS1	
12 14 311	Y-710J	
12 14 315	Y-719RS1	
12 14 316	Y-603J	60
12 14 319	Y-924J	1
12 14 321	Y-904M1	
12 14 323	Y-904M1	
12 14 324	Y-924J	1
12 14 334	Y9003AS	78
12 14 427	Y-741U	20
12 14 459	Y1038J	
18 26 357	Y9004AS	
4 423 206	Y1010AS	88
46 792 355	YE07	
46 792 359	YE07	
48 05 511	Y8009AS	
55 564 162	Y9003AS	78
90 093 867	Y-208T	
90 093 897	Y-208T	
90 510 924	Y-924J	1
90 540 864	Y-924J	1
91 153 919	Y-741U	20
93 178 047	Y8003J	62
93 178 411	YE07	
93 190 433	Y1030J	70
94 133 759	Y-904M1	
94 175 158	Y-904M1	
94 319 700	Y-710J	
94 439 218	Y-306R	
94 481 972	Y-719RS1	
95 51 6186	Y1047AS	
95 514 173	Y1010AS	88
95 518 024	Y1010AS	88
95 52 2519	Y1047AS	
96 440 144	Y8009AS	
97 044 037	Y-719RS1	
97 210 818	Y-541J	42
97 725 357	Y-810	
PSA	→ NGK	D-Power
5960.12	YE04	40
5960.19	YE04	40
5960.64	Y1005J	56
5960.65	Y1005J	56
5960.66	Y-504J	24
5960.67	Y-504J	24
5960.76	YE12	
5960.77	YE12	
5960.78	YE05	73
5960.79	YE05	73
5960.88	Y-548J	75
5960.89	Y-548J	75
5960.99	YE08	

PSA	→ NGK	D-Power
5960.A0	YE08	
5960.A3	Y8005J	64
5960.A4	Y8005J	64
5960.E6	Y8001AS	58
5960.E9	YE04	40
5960.F4	Y-504J	24
5960.F5	Y-504J	24
5960.F8	YE12	
5960.F9	YE05	73
5960.G6	YE08	
5960.K4	Y8005J	64
5960.L4	Y9001AS	72
5961.22	Y-810	
5961.35	Y-810	
5961.39	Y-924J	1
5961.53	Y-208T	
5961.54	Y-208T	
5961.58	Y-208T	
5961.A3	Y8005J	64
5961.A4	Y8005J	64
5961.K4	Y8005J	64
5962.03	Y-924J	1
5962.1Q	Y-738U	
5962.2Y	Y-503J	10
5962.2Z	Y-503J	10
5962.3C	Y-504J	24
5962.3E	Y-504J	24
5962.3H	Y-924J	1
5962.7F	Y-504J	24
5962.7G	Y-504J	24
5962.J3	Y-910J	3
5962.T1	Y-910J	3
5962.T2	Y-933J	25
79 325 658 82	Y-810	
79 325 677 18	Y-208T	
91 508 602 80	Y-924J	1
91 908 610 80	Y-924J	1
95 493 206	Y-208T	
95 534 788	Y-208T	
96 236 383	Y-504J	24
96 374 699 80	YE04	40
96 389 858	Y-504J	24
96 501 000 80	YE05	73
96 525 482 80 00	YE08	
96 831 952 80	Y8001AS	58
98 090 881 80	Y8012AS	
HG 2621	Y-810	
RENAULT	→ NGK	D-Power
11 06 508 19R	Y1010AS	88
11 06 514 92R	Y1047AS	
11 06 514 92R	Y1047AS	
11 06 517 49R	Y1010AS	88

RENAULT	→ NGK	D-Power
11 06 556 87R	Y1035AS	77
11 06 570 31R	Y1047AS	
11 06 570 31R	Y1047AS	
50 01 001 587	Y-208T	
77 00 100 558	Y-506J	7
77 00 100 586	Y-740U	22
77 00 100 635	Y-516J	12
77 00 105 290	Y-927J	19
77 00 111 323	Y-732J	4
77 00 662 199	Y-208T	
77 00 733 076	Y-924J	1
77 00 741 144	Y-924J	1
77 00 854 538	Y-933J	25
77 00 855 865	Y-913J	15
77 00 856 238	Y-913J	15
77 00 856 292	Y-933J	25
77 00 861 906	Y-730U	17
77 01 039 387	Y-924J	1
77 01 057 806	CZ24	
77 01 058 142	Y-522J	
77 01 069 730	Y-732J	4
77 01 349 475	Y-924J	1
82 00 090 817	Y-913J	15
82 00 426 227	Y-516J	12
82 00 490 950	Y-732J	4
82 00 546 885	CZ24	
82 00 561 251	CZ167	91
82 00 682 592	Y1035AS	77
82 00 787 721	Y-516J	12
82 00 794 920	Y1036AS	
85 49 971 00	Y-810	
86 71 004 853	Y-732J	4
SAAB	→ NGK	D-Power
93 178 411	YE07	
SSANGYONG	→ NGK	D-Power
A 664 159 00 01	Y-536J	81
A 665 159 02 01	Y-536J	81
A 667 159 00 01	Y-537AS	
SUBARU	→ NGK	D-Power
22439-AA000	Y-606J	
SUZUKI	→ NGK	D-Power
09900-F8Q01	Y-516J	12
09900-RF001	Y-701J	39
18550-79J50	Y1030J	70
18550-79J80	Y9003AS	78
18550-79J81	Y9003AS	78
18550-80KA0	Y1036AS	
TOYOTA	→ NGK	D-Power
19850-0R010	Y1012J	65
19850-0R020	Y1012J	65
19850-0R022	Y1012J	65
19850-0W010	Y-542J	45

TOYOTA	→ NGK	D-Power
19850-26010	Y1012J	65
19850-26020	Y1012J	65
19850-26021	Y1012J	65
19850-26022	Y1012J	65
19850-27010	Y-531J	44
19850-30010	Y-531J	44
19850-54030	Y-118T1	
19850-54031	Y-118T1	
19850-54050	Y-118R	
19850-54090	Y-715R	
19850-54120	Y-715R	
19850-56012	Y-178T	
19850-56021	Y-128T	
19850-56022	Y-128T	
19850-64010	Y-146R	
19850-64020	Y-703R	
19850-64031	Y-532J	
19850-64050	Y-532J	
19850-67020	Y1013J	63
19850-67030	Y1013J	63
19850-68010	Y-147T	
19850-68020	Y-197T	
19850-68030	Y-128T	
19850-68040	Y-178T	
19850-68060	Y-197R	
VOLVO	→ NGK	D-Power
3121 6248	YE05	73
3071 1106	YE04	40
3072 5069	Y1005J	56
8631 607	YE12	
8653 698	Y1005J	56
8653 880	Y8008AS	74
VW Group	→ NGK	D-Power
03L 963 319 A	Y1002AS	57
03L 963 319 C	Y1002AS	57
059 963 319 A	Y-501U	31
059 963 319 E	Y-609AS	49
059 963 319 F	Y-609AS	49
060 963 319 F	Y1002AS	57
N 019 1001	Y-207T	
N 019 1002	Y-207T	
N 019 1005	Y-918J	2
N 019 1006	Y-918J	2
N 101 401 04	Y-732J	4
N 101 401 05	Y-732J	4
N 102 130 01	Y-918J	2
N 102 130 02	Y-918J	2
N 105 792 01	Y-741U	20
N 105 792 02	Y-741U	20
N 105 798 02	YE14	48
N 105 798 03	CZ304	55
N 105 798 05	CZ304	55

VW Group	→ NGK	D-Power
N 105 916 02	Y-607AS	50
N 105 916 03	Y-607AS	50
N 105 916 04	CZ104	52
N 105 916 08	CZ104	52

ACDelco	→ NGK	V-Line
44	B6S	
45	B-4	
46	B-4	
48	B-4	
40 TS	BP7FS	
41 TS	BP6FS	
41 XL	B9ES	
41 XLS	BP7ES	
41-101	ITR4A15	
41-109	ILTR6E11	
412 XLS	BP7ES	
414 XLS	BP6ES	4
41-600	TR55IX	
41-601	BPR6ES	2
41-602	FR5	
41-603	FR4	
41-606	TR55	
41-608	FR45	
41-610	FR4	
41-611	FR45	
41-627	BKR4E-11	
41-628	FR4	
41-812	TR6IX	
41-900	TR5	
41-902	TR55	
41-904	TR5	
41-905	UR4	
41-906	TR5	
41-907	TR5	
41-908	BPR5EFIX-13P	
41-910	TR5	
41-913	TR55	
41-919	TR55	
41-921	TR55	
41-928	TR55-1	
41-929	TR55	
41-932	TR55	
41-933	ITR4A15	
41-936	TR55	
41-940	TR55	
41-942	TR55	
41-943	TR55	
41-947	TR55	
41-948	TR4IX	
41-950	PTR5C-13	
41-952	BPR5EFIX-13P	
41-963	PTR5C-13	
41-974	PZTR5A-15	
41-983	PZTR5A-15	
41-987	PTR5C-13	
42 F	B6HS	
42 FF	B6HS	

ACDelco	→ NGK	V-Line
42 FS	BP6HS	18
42 TS	BP6FS	
42 XL	B8ES	
42 XLS	BP6ES	4
422 Z	B5HS	
425 F	B6HS	
425 Z	B6HS	
426 FS	BP6HS	18
43 F	B6HS	
43 FFS	BP6HS	18
43 FS	BP6HS	18
43 N	B7ES	
43 TS	BP6FS	
43 XL	B7ES	
43 XLS	BP6ES	4
430 Z	B7HS	
436 XLS	BP9ES	
438 XLS	BP8ES	
44 F	B5HS	
44 FF	B5HS	
44 FFS	BP5HS	
44 N	B6ES	
44 NS	BP5ES	8
44 TS	BP5FS	
44 XL	B6ES	
44 XLO	BP5ES	8
44 XLS	BP5ES	8
440 XLS	BP8ES	
445 Z	B8HS	
45 F	B5HS	
45 FF	B5HS	
45 FFS	BP5HS	
45 L	B-4L	
45 NS	BP5ES	8
45 TS	BP4FS	
45 XL	B6ES	
45 XLS	BP5ES	8
46 F	B5HS	
46 FF	B5HS	
46 FFS	BP5HS	
46 N	B5ES	
46 TS	BP4FS	
46 XL	B5ES	
46 XLS	BP4ES	
83 CTS	AP6FS	
83 TS	AP6FS	
84 T	A6FS	
84 TS	AP5FS	
85 TS	AP5FS	
86 TS	AP5FS	
B 4021	B6S	
B 4031	B-4	



ACDelco	→ NGK	V-Line
B 43	B6S	
B 44 FS	BP5HS	
B 45	B-4	
C 41	B7S	
C 42 CFS	BP6HS	18
C 42 CLTS	BP6EFS	5
C 42 CXLS	BP6ES	4
C 42 LTS	BP6EFS	5
C 42 N	B7ES	
C 42 XLS	BP5ES	8
C 421	B6S	
C 43	B6S	
C 43 CXLS	BP6ES	4
C 43 L	B-6L	
C 43 N	B6ES	
C 44	B6S	
C 44 N	B6ES	
C 44 NS	BP5ES	8
C 44 XL	B6ES	
C 45	B-4	
C 45 L	B-4L	
C 46	B-4	
C 47	B-4	
C 47 W	B-4	
C 81	AB-8	
C 82	AB-7	
C 82 T	A7FS	
C 83	AB-7	
C 83 T	A6FS	
C 84 T	A6FS	
C 85	AB-6	
C 85 TS	AP5FS	
C 86	AB-6	
C 87	AB-6	
CFR 1 CLS	BCPR7ES	
CFR 2 CLS	BKR6ES	28
CR 42 CFS	BPR6FS	
CR 42 CXLS	BPR6ES	2
CR 42 N	BR7ES	
CR 43 CXLS	BPR6ES	2
CR 43 N	BR6ES	
CR 43 TS	BPR5FS-11	
CR 43 TSM	BPR5FS-11	
CR 44 N	BR6ES	
CR 44 NS	BPR5ES	6
CR 44 TS	BPR5FS-11	
CR 45 TS	UR4	
CR 83 T	AR6FS	
FR 2 LS	BKR6ES	28
FR 2 LSK	BKR6ES	28
FR 3 CLS	BKR5ES	35
FR 3 CLS 6	BKR5ES-11	33

ACDelco	→ NGK	V-Line
FR 3 LM	ZFR5A-11	
FR 3 LS	BKR5ES	35
FR 3 LS 6	BKR5ES-11	33
FR 3 LSJ	BKR4E-11	
FR 3 LSK	BKR5ES	35
FR 4 LE	ZFR4F-11	
FR 4 LSJ	BKR4E-11	
FR 5 LS	BKR5ES	35
M 40 FF	B9HS	
M 41 FF	B8HS	
M 41 K	B8S	
M 42 FF	B7HS	
M 42 K	B7S	
M 43 FF	B6HS	
M 44 B	B6S	
M 44 C	B6S	
M 44 L	B-6L	
M 45	B-4	
M 45 FF	B5HS	
M 47	B-4	
M 86	AB-6	
MB 42 K	B6S	
MC 41	B8S	
MC 41 F	B8HS	
MC 42	B8S	
MC 42 F	B7HS	
MC 44	B7S	
MR 42 LTS	BPR6EFS	7
MR 43 LTS	BPR6EFS	7
MR 45	B-4	
R 41 CF	BR7HS	
R 41 CXLS	BPR7ES	19
R 41 TS	BPR6FS	
R 415 TS	BPR6FS	
R 42 CFS	BPR6HS	3
R 42 CLTS	BPR6EFS	7
R 42 CTS	BPR6FS	
R 42 CXL	BR8ES	
R 42 CXLS	BPR6ES	2
R 42 FS	BPR6HS	3
R 42 LTS	BPR6EFS	7
R 42 LTSM	BPR5EFS-13	
R 42 TS	BPR6FS	
R 42 TSM	BPR6FS	
R 42 XL	BR8ES	
R 42 XLS	BPR6ES	2
R 42 XLSM	ZGR5C	
R 425 LTS	BPR6EFS	7
R 425 TS	BPR6FS	
R 426 FS	BPR6HS	3
R 43 CFS	BPR6HS	3
R 43 CNTSE	TR5-1	





ACDelco	→ NGK	V-Line
R 43 CTS	BPR6FS	
R 43 CTS 6	BPR6FS	
R 43 CXL	BR7ES	
R 43 CXLS	BPR6ES	2
R 43 FS	BPR6HS	3
R 43 LTS	BPR6EFS	7
R 43 LTSE	TR4	
R 43 LTSX	BPR6EFS-13	
R 43 N	BR7ES	
R 43 NTSE	TR5-1	
R 43 TS	BPR6FS	
R 43 TSK	BPR6FS	
R 43 TSX	BPR6FS	
R 43 XL	BR7ES	
R 43 XLS	BPR6ES	2
R 44 CNTSE	TR5-1	
R 44 CXL	BR6ES	
R 44 CXLS	BPR5ES	6
R 44 LTS	BPR5EFS	
R 44 LTS 6	BPR5EFS-13	
R 44 LTS 6K	BPR5EFS-13	
R 44 LTSM	TR4	
R 44 LTSM 6	TR4	
R 44 N	BR6ES	
R 44 NS	BPR5ES	6
R 44 NTSE	TR5-1	
R 44 TSX	BPR5FS-15	
R 44 XL	BR6ES	
R 44 XLS	BPR5ES	6
R 44 XLS 6	BPR4ES-13	
R 44 XLSE	ZGR5C	
R 44 XLSM	ZGR5C	
R 45 LTS 6	BPR5EFS-13	
R 45 LTS 6K	BPR5EFS-13	
R 45 NS	BPR5ES	6
R 45 NSX	BPR5ES-13	
R 45 NTSE	TR5-1	
R 45 TS	BPR4FS	
R 45 TSX	BPR4FS-15	
R 45 XL	BR6ES	
R 45 XLS	BPR5ES	6
R 46 LTS	BPR5EFS	
R 46 N	BR5ES	
R 46 SZ	XR45IX	
R 46 TS	BPR4FS	
R 46 TSX	BPR4FS-15	
R 46 XL	BR5ES	
R 46 XLS	BPR4ES	
R 83 CT	AR6FS	
R 83 CTS	APR6FS	
R 83 TS	APR6FS	
R 84 TS	APR5FS	

ACDelco	→ NGK	V-Line
R 85 TS	APR5FS	
S 40 F	B9HS	
S 40 XLR	BR8ES	
S 41 F	B8HS	
S 41 XL	B9ES	
S 41 XLG	B8ECS	
S 42	B7S	
S 42 F	B7HS	
S 42 FR	BR7HS	
S 42 XL	B8ES	
S 42 XLR	BR8ES	
S 43 XL	B7ES	
S 43 XLR	BR7ES	
S 44	B6S	
S 44 F	B5HS	
S 44 XL	B6ES	
S 45 F	B5HS	
S 46	B-4	
S 81 F	AB-8	
S 82 F	AB-8	
S 83 F	AB-7	
S 85 F	AB-6	
SB 41	B7S	
SN 46	B-4	
TC 42	B8S	
TC 45	B6S	
TC 81	AB-8	
TC 82	AB-8	
TC 83	AB-7	
TC 85	AB-6	
TC 86	AB-6	
AUTOLITE / TUNER	→ NGK	V-Line
12	BP7FS	
13	BP6FS	
14	BP6FS	
15	BP5FS	
16	BP4FS	
23	BPR6FS	
24	BPR6FS	
26	BPR4FS-15	
27	BPR4FS-15	
32	AP7FS	
33	AP6FS	
34	AP6FS	
35	AP5FS	
36	AP5FS	
37	AP5FS	
43	APR6FS	
44	APR6FS	
45	APR5FS	
46	APR5FS	
52	BP7ES	



AUTOLITE / TUNER →	NGK	V-Line
53	BP6ES	4
54	BP6ES	4
55	BP5ES	8
56	BP5ES	8
57	BP4ES	
62	BP7ES	
63	BPR6ES	2
64	BPR6ES	2
65	BPR5ES	6
66	BPR5ES	6
67	BPR4ES	
94	BP7EFS	
102	BP7EFS	
103	BPR6EFS	7
104	BPR6EFS	7
105	BPR5EFS	
106	BPR5EFS	
113	A7FS	
115	A6FS	
117	A6FS	
124	AR6FS	
156	AP5FS	
166	APR5FS	
203	BPR6FS	
215	B-6L	
216	B-6L	
217	B-4L	
218	B-4L	
273	BP6HS	18
274	BP6HS	18
275	BP5HS	
276	BP5HS	
283	BPR7HS	
284	BPR6HS	3
292	B8S	
294	B6S	
295	B-4	
297	B-4	
306	B-4	
312	B8S	
313	B7S	
314	B6S	
315	B6S	
316	B6S	
317	B-4	
344	AR6FS	
353	B8S	
354	B6S	
355	B6S	
356	B-4	
357	B-4	
372	AB-8	

AUTOLITE / TUNER →	NGK	V-Line
373	AB-7	
374	AB-7	
375	AB-6	
376	AB-6	
377	AB-6	
378	AB-6	
386	AB-6	
393	B7ES	
394	B6ES	
395	B5ES	
396	B5ES	
397	B5ES	
402	BR8ES	
403	BR6ES	
404	BR6ES	
405	BR5ES	
406	BR5ES	
411	B9HS	
413	B7HS	
414	B6HS	
415	B5HS	
416	B5HS	
424	B6HS	
436	B-6L	
437	B-4L	
472	B9EFS	
483	BR7EFS	
494	B-6L	
495	B-6L	
497	B-4L	
515	BP5HS	
516	BP5HS	
535	B5HS	
584	AR6FS	
603	BPR6EFS-13	
604	BPR6EFS-13	
605	BPR6EFS-13	
646	BPR5ES-13	
664	BPR6FS	
665	BPR5FS-15	
666	BPR4FS-15	
667	BPR4FS-15	
723	BPR6FS	
724	BPR6FS	
725	BPR5FS-11	
726	BPR4FS	
727	BPR4FS-11	
744	APR5FS	
746	APR5FS	
747	APR5FS	
763	TR5-1	
764	BPR6EFS	7





AUTOLITE / TUNER →	NGK	V-Line
765	BPR5EFS	
766	BPR5EFS	
784	AR6FS	
804	AR6FS	
865	BPR5EFS	
884	BPR6EFS-13	
915	ZGR5C	
925	ZGR5C	
935	BPR5ES	6
945	BPR5ES	6
985	ZFR4F-11	
996	B-6L	
2272	AB-7	
2413	R7376-10	
2416	B8EG	
2543	TR5-1	
2544	TR5-1	
2545	TR5-1	
2546	TR5-1	
2585	BPR5ES	6
2593	B9ES	
2594	B9ES	
2612	B9ES	
2613	B9ES	
2614	B8ES	
2615	B7ES	
2616	B6ES	
2635	B8HS	
2636	B7HS	
2653	B7HS	
2654	B7HS	
2655	B6HS	
2656	B5HS	
2675	B-6L	
2676	B-6L	
2695	AB-8	
2696	AB-7	
2697	AB-6	
2772	AB-8	
2775	AB-6	
3012	B8S	
3013	B7S	
3014	B6S	
3017	B-4	
3035	AB-6	
3036	BPR4FS-15	
3055	A6FS	
3116	AB-6	
3203	BPR6ES	2
3204	BPR6ES	2
3205	BPR5ES	6
3206	BPR5ES	6

AUTOLITE / TUNER →	NGK	V-Line
3207	BPR5ES	6
3243	BPR6EFS	7
3244	BPR6EFS	7
3245	BPR5EFS	
3246	BPR5EFS	
3286	APR6FS	
3303	BPR6FS	
3325	B-6L	
3327	B-4L	
3364	BPR6HS	3
3404	AR6FS	
3423	B8S	
3462	BR7ES	
3463	BR6ES	
3464	BR6ES	
3465	BR5ES	
3466	BR5ES	
3507	B-6L	
3565	BPR5EFS	
3586	BPR5ES-13	
3604	BPR5FS-15	
3605	BPR4FS-15	
3606	BPR4FS-15	
3607	BPR4FS-15	
3684	BR7HS	
3704	BR8ES	
3705	BR6ES	
3706	BR6ES	
3724	BPR5EFS	
3885	ZGR5C	
3896	ZGR5C	
3922	BCPR7ES	
3924	BKR6ES	28
3926	BKR5ES	35
3985	BPR5FS-15	
4043	BPR6ES-11	13
4052	B9ES	
4053	B9ES	
4054	B8ES	
4055	B7ES	
4056	B6ES	
4092	B7HS	
4093	B7HS	
4113	BP6HS	18
4114	BP6HS	18
4123	BPR6HS	3
4251	BP8ES	
4252	BP7ES	
4253	BP6ES	4
4263	BPR6ES	2
4265	BPR5ES	6
5143	TR5-1	



AUTOLITE / TUNER	→ NGK	V-Line
5224	BKR5E	35
9062	BUR6ET	1
9063	BUR6ET	1
9064	BP5ET	
9921	BCPR6ET	
AP 63	PFR6B	
APP 392 411	BKR5EP-11	
XP 5682	ILZKAR7A10	
BERU	→ NGK	V-Line
0 001 325 701	BP5ES	8
0 001 325 704	BP5ESZ	
0 001 325 705	BCP5ES	16
0 001 325 710	BP5ET	
0 001 330 104	BUR5ET	22
0 001 330 112	BUR5ET-10	21
0 001 330 113	BUR5ET	22
0 001 330 116	BKUR5ET-10	
0 001 330 119	BKUR5ET	29
0 001 330 501	BKR6EK	20
0 001 330 702	BP5ES	8
0 001 330 707	BCP5ES	16
0 001 330 709	BP5ET-10	
0 001 330 713	BP5ESZ	
0 001 330 717	ZFR5F	53
0 001 330 718	ZGR5A	15
0 001 330 725	BCP5ES	16
0 001 330 726	BP5ESZ	
0 001 330 731	BCP5ES	16
0 001 330 780	BKR6EZB	
0 001 330 904	IFR5D10	
0 001 335 107	BKUR6ET-10	24
0 001 335 108	BUR6ET	1
0 001 335 702	BP6ES	4
0 001 335 707	B6ES	
0 001 335 709	BUR6ET	1
0 001 335 714	BP6ESZ	
0 001 335 721	BCP6ES	17
0 001 335 725	BCP6ES	17
0 001 335 729	BKR6ES	28
0 001 335 732	BKR6EK	20
0 001 335 737	BP6ESZ	
0 001 335 742	ZFR5P-G	41
0 001 335 905	IFR6D10	
0 001 335 910	IFR6D10	
0 001 335 911	PZFR5D-11	34
0 001 335 914	PFR6Q	37
0 001 340 103	BKUR6ET	27
0 001 340 702	BP6ES	4
0 001 340 704	BUR6ET	1
0 001 340 706	BCP6ET	
0 001 340 707	BP6ESZ	
0 001 340 716	BCP6ES	17

BERU	→ NGK	V-Line
0 001 340 717	BCP6ET	
0 001 340 723	BKR6ES	28
0 001 340 806	BKR6ES	28
0 001 340 903	BP6ES	4
0 001 340 908	PFR7Q	
0 001 345 702	BP7ES	
0 001 345 704	BUR6ET	1
0 001 345 711	BP7ES	
0 001 345 720	BCP7ES	
0 001 350 903	BP7ES	
0 001 355 700	B9ES	
0 001 400 701	B6HS	
0 001 430 700	BP5HS	
0 001 430 701	B5HS	
0 001 435 700	BP6HS	18
0 001 435 705	B6HS	
0 001 440 700	BP6HS	18
0 001 445 700	BP7HS	
0 001 445 702	B7HS	
0 001 450 702	B8HS	
0 001 455 702	B9HS	
0 001 529 302	B-4	
0 001 625 700	BP5EFS	
0 001 625 702	BP5EFS	
0 001 630 700	BP5EFS	
0 001 630 704	BP5EFS	
0 001 635 700	BP6EFS	5
0 001 635 709	BP6EFS	5
0 001 640 700	BP6EFS	5
0 001 640 704	BP6EFS	5
0 001 640 705	BP6EFS	5
0 001 645 700	BP7EFS	
0 001 645 703	BP7EFS	
0 001 735 700	AP6FS	
0 001 740 700	AP6FS	
0 001 820 700	AB-6	
0 001 835 700	AB-7	
0 001 845 700	AB-7	
0 002 235 901	PLZKBR7B8G	
0 002 240 902	PLZKBR7B8G	
0 002 240 907	PLZKBR7B8G	
0 002 240 911	PLZKBR7B8G	
0 002 325 700	BPR5ES	6
0 002 330 204	BKR5EYA-11	39
0 002 330 701	BPR5ES	6
0 002 330 702	BPR5ES-11	
0 002 330 703	BKR5ES	35
0 002 330 704	BKR5ES-11	33
0 002 330 706	BPR5EKU	
0 002 330 710	BKR5EK	23
0 002 330 712	BCRE527Y	
0 002 330 713	BKR5EY	



BERU	→ NGK	V-Line
0 002 330 714	BKR5EYA	
0 002 330 794	ZFR5F	53
0 002 335 100	BCPR7ET	
0 002 335 500	BKR6EK	20
0 002 335 701	BPR6ES	2
0 002 335 704	BR6ES	
0 002 335 706	BPR6ES-11	13
0 002 335 707	BKR6ES	28
0 002 335 708	BKR6ES-11	14
0 002 335 712	BKR6EY	
0 002 335 713	BKR6EYA	
0 002 335 714	BKR6EYA-11	
0 002 335 715	ZFR6F-11	
0 002 335 719	LFR6B	47
0 002 335 902	BCPR6EP-11	
0 002 335 903	BCPR6EP-11	
0 002 335 904	BKR6EP-8	
0 002 335 911	BKR6EQU	30
0 002 340 102	BKR6EKUB	
0 002 340 500	BKR6EK	20
0 002 340 501	BKR6EKE	
0 002 340 504	BKR6EKC	26
0 002 340 701	BPR6ES	2
0 002 340 702	BKR6ES	28
0 002 340 703	BPR6ES-11	13
0 002 340 704	BKR6ES-11	14
0 002 345 701	BPR7ES	19
0 002 345 702	BCPR7ES	
0 002 345 704	BCPR7ET	
0 002 435 701	BPR6HS	3
0 002 630 701	PTR5A-13	25
0 002 630 715	LTR6B-10T	
0 002 630 900	TR55IX	
0 002 635 700	BPR6EFS	7
0 002 635 701	BPR6EFS-13	
0 002 640 100	BUR6EFSZ	
0 002 640 700	BPR6EFS	7
0 002 640 701	BPR6FS	
0 002 640 900	PTR5A-13	25
12 FR-6 DU	DCPR7E-N-10	43
12 FR-6 DU	DCPR7E-N-10	
12 FR-6 LUX	ZKR7A-10	42
12 KR-4 MIPS	ILNAR8B7G	
12 VR-7 SPUX	PLZKAR6A-11	51
12 VR-7 SPUX	PLZKAR6A-11	
12 ZR-6 SP03	PLZKBR7B8G	
12 ZR-6 SP2	PLZKBR7B8G	
12 ZR-6 SPP21	PLZKBR7B8G	
12 ZR-7 SP03	PLZKBR7B8G	
125/14/3	B5ES	
125/14/3A	BP5ES	8
12VR-8 SE	LZKAR7A	54

BERU	→ NGK	V-Line
12VR-8 SE	LZKAR7A	
12VR-8NIPS2	ILKAR7J7G	
14 F-5 DPURS2	PFR7S8EG	50
14 F-5 DPURS2	PFR7S8EG	
14 F-5 DU	BCP7ES	
14 F-6 DPUR 021	PFR7Q	
14 F-6 DSR	BKR6ES	28
14 F-6 DTU	BCP6ET	
14 F-6 DU0	BCP6ES	17
14 F-6 DU0R	BKR6ES	28
14 F-6 LPURW03	PZFR6R	52
14 F-6 LPURW03	PZFR6R	
14 F-7 DPUR02	PFR6Q	37
14 F-7 DPURX2	IFR6D10	
14 F-7 DU	BCP6ES	17
14 F-7 DU0	BCP6ES	17
14 F-7 DU0R	BKR6ES	28
14 F-7 HPURX2	PZFR5D-11	34
14 F-7 HUR2	ZFR5P-G	41
14 F-7 HURU02	ZFR6T-11G	44
14 F-7 HURU02	ZFR6T-11G	
14 F-7 LDUR	BKR6EK	20
14 F-7 LDUR4	BKR6EK	20
14 F-8 DU	BCP5ES	16
14 F-8 DU0	BCP5ES	16
14 F-8 DU4	BCP5ES	16
14 F-8 DUR	BKR6EZB	
14 F-8 LDUSR	BKR6EK	20
14 F-8 LUR	ZFR5F	53
14 F-9 DU0	BCP5ES	16
14 FGH-6 DTUR	BKUR6ET	27
14 FGH-7 DPURX2	IFR6D10	
14 FGH-7 DTURX	BKUR6ET-10	24
14 FGH-8 DPURX2	IFR5D10	
14 FGH-8 DTURW	BKUR5ET	29
14 FGH-8 DTURX0	BKUR5ET-10	
14 FGR-6 DDU	BKR6EKUB	
14 FGR-7 CTU	BCPR7ET	
14 FR-5 DTU	BCPR7ET	
14 FR-5 DU	BCPR7ES	
14 FR-6 DU	BKR6ES	28
14 FR-6 DUX	BKR6ES-11	14
14 FR-6 LDU	BKR6EK	20
14 FR-6 LDU3	BKR6EKE	
14 FR-6 LDUW	BKR6EKC	26
14 FR-7 DQUP7	BKR6EQU	30
14 FR-7 DU	BKR6ES	28
14 FR-7 DUX	BKR6ES-11	14
14 FR-7 KPU	BKR6EP-8	
14 FR-7 KPUV	BCPR6EP-11	
14 FR-7 KPUX	BCPR6EP-11	
14 FR-7 KU	BKR6EY	



BERU	→ NGK	V-Line
14 FR-7 KU0	BKR6EYA	
14 FR-7 KU0X	BKR6EYA-11	
14 FR-7 LDU	BKR6EK	20
14 FR-7 LUX	ZFR6F-11	
14 FR-7 MU2	LFR6B	47
14 FR-7 NUX2	LFR6C-11	48
14 FR-7 NUX2	LFR6C-11	
14 FR-8 DU	BKR5ES	35
14 FR-8 DUX	BKR5ES-11	33
14 FR-8 HU	BCRE527Y	
14 FR-8 KU	BKR5EY	
14 FR-8 KU0U	BKR5EYA-11	39
14 FR-8 KUO	BKR5EYA	
14 FR-8 LDUOX4	BKR5EK	23
14 FR-8 LU2	ZFR5F	53
14 FR-8 MU2	LFR5B	46
14 FR-8 MU2	LFR5B	
14 G-8 DTU	BUR5ET	22
14 GH-7 DTUR	BUR6ET	1
14 GH-8 DTUR	BUR5ET	22
14 GH-8 DTURX	BUR5ET-10	21
14 GR-8 DTU	BPR5EKU	
14 K-5 DU	BP7EFS	
14 K-5 DU0	BP7EFS	
14 K-6 D	BP6EFS	5
14 K-6 DU	BP6EFS	5
14 K-6 DU0	BP6EFS	5
14 K-7 D	BP6EFS	5
14 K-7 DU	BP6EFS	5
14 K-7 DU0	BP6EFS	5
14 K-8 DU	BP5EFS	
14 K-8 DU0	BP5EFS	
14 K-9 DU	BP5EFS	
14 K-9 DU0	BP5EFS	
14 KGR-6 KQU	BUR6EFSZ	
14 KR-6 BU	BPR6FS	
14 KR-6 DU	BPR6EFS	7
14 KR-7 DU	BPR6EFS	7
14 KR-7 DUX	BPR6EFS-13	
14 KR-8 DPU0V	TR55IX	
14 KR-8 MPX	PTR5A-13	25
14 KR-8 MUV	PTR5A-13	25
14 KR-8 STUX	LTR6B-10T	
14 R-5 DU	BPR7ES	19
14 R-6 B	BPR6HS	3
14 R-6 BU	BPR6HS	3
14 R-6 D	BPR6ES	2
14 R-6 DU	BPR6ES	2
14 R-6 DUX	BPR6ES-11	13
14 R-7 B	BPR6HS	3
14 R-7 BU	BPR6HS	3
14 R-7 CU	BR6ES	

BERU	→ NGK	V-Line
14 R-7 D	BPR6ES	2
14 R-7 DU	BPR6ES	2
14 R-7 DUX	BPR6ES-11	13
14 R-8 DU	BPR5ES	6
14 R-8 DUX	BPR5ES-11	
14 R-9 DU	BPR5ES	6
14 X-AU	B6HS	
14 Z-2 C1	BR9EIX	
14 Z-3 A1	B9HS	
14 Z-3 AU	B9HS	
14 Z-3 C1	B9ES	
14 Z-3 CU	B9ES	
14 Z-4 AU	B8HS	
14 Z-6 A2	B6HS	
14 Z-7 AU	B7HS	
14-10 D	BP4ES	
14-10 E	B-4	
14-3 A1	B8HS	
14-3 AS1	BR8HIX	
14-3 AU	B8HS	
14-3 CS1	BR8EIX	
14-3 DP2	BR8EIX	
14-4 A1	B8HS	
14-4 A2	B7HS	
14-4 AS1	BR8HIX	
14-4 AU	B7HS	
14-4 B2	BP7HS	
14-4 C1	B8ES	
14-4 C2	B7ES	
14-4 CS1	BR8EIX	
14-4 DP0	BP7ES	
14-5 A	B7HS	
14-5 AU	B7HS	
14-5 B	BP7HS	
14-5 BU	BP7HS	
14-5 C	B7ES	
14-5 D	BP7ES	
14-5 D1	BP7ES	
14-5 DP1	BP7ES	
14-5 DTU	BUR6ET	1
14-5 DU	BP7ES	
14-5 DU0	BP7ES	
14-5 E	B7S	
145/14	B5HS	
145/14/3	B5ES	
145/14/3A	BP5ES	8
145/14/5	B-4	
145/18	AB-6	
145/18K	AP5FS	
145/1A	BP5HS	
14-6 B	BP6HS	18
14-6 BU	BP6HS	18





BERU	→ NGK	V-Line
14-6 C	B6ES	
14-6 D	BP6ES	4
14-6 D1	BP6ES	4
14-6 DPO	BP6ES	4
14-6 DTU	BUR6ET	1
14-6 DU	BP6ES	4
14-6 DU0	BP6ESZ	
14-7 A	B6HS	
14-7 AU	B6HS	
14-7 B	BP6HS	18
14-7 BU	BP6HS	18
14-7 C	B6ES	
14-7 CU	B6ES	
14-7 D	BP6ES	4
14-7 DTU	BUR6ET	1
14-7 DU	BP6ES	4
14-7 DU0	BP6ESZ	
14-7 E	B6S	
14-8 A	B5HS	
14-8 AU	B5HS	
14-8 B	BP5HS	
14-8 BU	BP5HS	
14-8 C	B5ES	
14-8 C1	B6ES	
14-8 D	BP5ES	8
14-8 DTU	BP5ET-10	
14-8 DU	BP5ES	8
14-8 DU0	BP5ESZ	
14-8 E	B-4	
14-8 LUR	ZGR5A	15
14-9 C	B5ES	
14-9 D	BP5ES	8
14-9 DTU	BP5ET	
14-9 DU	BP5ES	8
14-9 DU0	BP5ESZ	
160/14/3	B6ES	
175/14	B6HS	
175/14/3	B6ES	
175/14/3A	BP6ES	4
175/14/5	B6S	
175/14A	BP6HS	18
175/18	AB-6	
175/18K	AP6FS	
18 K-12 B	AP5FS	
18 K-6 BU	AP6FS	
18 K-7 B	AP6FS	
18 K-7 BU	AP6FS	
18 K-8 B	AP5FS	
18 K-8 BU	AP5FS	
18-10 A	AB-6	
18-10 AU	AB-6	
18-4 A1	AB-7	

BERU	→ NGK	V-Line
18-4 A2	AB-7	
18-5 A	AB-7	
18-5 AS	AB-7	
18-5 AU	AB-7	
18-7 A	AB-6	
18-7 AU	AB-7	
18-8 A	AB-6	
190/14 Z	B6HS	
200/14/3	B6ES	
200/14/3A	BP6ES	4
200/14/3K	BP6EFS	5
200/14A	BP6HS	18
215/14/3A	BP6ES	4
225/14	B7HS	
225/14/3	B7ES	
225/14/3A	BP7ES	
225/14/5	B7S	
225/14A	BP7HS	
225/18	AB-7	
225/18S	AB-7	
230/14/3A	BP7ES	
235/14/3P	BP7ES	
240/14	B7HS	
240/14 A	BP7HS	
240/14 S	BR8HIX	
240/14/3	B7ES	
240/18	AB-7	
260/14	B8HS	
260/14 S	BR8HIX	
260/14/3	B8ES	
260/18	AB-8	
265/14/3P	BR8EIX	
280/14	B8HS	
280/14/3S	BR8EIX	
280/14/3Z	B9ES	
280/14Z	B9HS	
310/14/3Z	BR9EIX	
45/18	AP5FS	
95/14/3A	BP4ES	
95/14/5	B-4	
95/18	AB-6	
D 175/14	B6HS	
D 175/14/3	B6ES	
D 200/14/3A	BP6ES	4
D 215/14/3	B7ES	
D 230/14/3A	BP7ES	
RS 16	BPR6HIX	
RS 18	BPR7HIX	
RS 33	BPR5EIX	
RS 35	BPR6EIX	
RS 37	BPR7EIX	
RS 39	BPR7EIX	



BERU	→ NGK	V-Line
Z 1	BP5ES	8
Z 2	BP5ET-10	
Z 3	ZGR5A	15
Z 4	ZFR5F	53
Z 5	BCP5ES	16
Z 6	BP5EFS	
Z 7	BP5EFS	
Z 8	BPR5ES	6
Z 9	BPR5ES-11	
Z 10	BP6HS	18
Z 11	BP6ES	4
Z 12	BUR6ET	1
Z 13	BKR6ES	28
Z 14	BKR6EK	20
Z 14SB	BKR6EKUE	
Z 15	BKR6ES	28
Z 16	BKR6ES-11	14
Z 17	BP6EFS	5
Z 18	BP6EFS	5
Z 19	BPR6HS	3
Z 20	BPR6ES	2
Z 21	BPR6ES-11	13
Z 22	BP6ES	4
Z 23	BKR6ES	28
Z 24	BKR6ES	28
Z 25	BP6EFS	5
Z 26	BPR6EFS	7
Z 27	BPR6ES	2
Z 28	BPR6ES-11	13
Z 29	BCP7ES	
Z 30	BCPR7ES	
Z 31	BP7EFS	
Z 32	AP6FS	
Z 33	AP6FS	
Z 37	B9HS	
Z 38	B9ES	
Z 39	B8HS	
Z 40	B7HS	
Z 41	BP7HS	
Z 42	BP7ES	
Z 43	BP7ES	
Z 44	BUR6ET	1
Z 45	BCPR7ET	
Z 46	BP7EFS	
Z 47	BPR7ES	19
Z 48	BP6HS	18
Z 49	BPR6FS	
Z 50	BP6ESZ	
Z 51	BUR6ET	1
Z 52	BCP6ET	
Z 53	BCP6ET	
Z 54	BCP6ES	17

BERU	→ NGK	V-Line
Z 55	BP6EFS	5
Z 56	BP6EFS	5
Z 57	B6HS	
Z 58	B6ES	
Z 59	BR6ES	
Z 60	BCPR7ET	
Z 61	BP6ESZ	
Z 62	BP6ESZ	
Z 63	BCP6ES	17
Z 64	BCP6ES	17
Z 67	BPR6EFS-13	
Z 68	B5HS	
Z 69	BP5ESZ	
Z 70	BP5ESZ	
Z 71	BCP5ES	16
Z 72	BKR5ES	35
Z 73	BKR5ES-11	33
Z 74	BKR5EK	23
Z 75	BUR5ET	22
Z 76	BP5ES	8
Z 77	BP5ESZ	
Z 78	BP5ET	
Z 79	BCP5ES	16
Z 80	BP5EFS	
Z 81	BP5EFS	
Z 82	BPR5ES	6
Z 85	B6HS	
Z 86	AB-7	
Z 87	AB-7	
Z 88	AB-6	
Z 89	BKUR6ET	27
Z 90	BKUR6ET-10	24
Z 91	BUR6ET	1
Z 92	BUR5ET	22
Z 93	BUR5ET-10	21
Z 94	BPR5EKU	
Z 95	BPR6EFS	7
Z 97	PTR5A-13	25
Z 98	BKR6EK	20
Z 99	BKR6ES-11	14
Z 100	BCP5ES	16
Z 101	BKR6EK	20
Z 103	BP7ES	
Z 104	BP6ES	4
Z 105	BKR6ES	28
Z 112	B-4	
Z 116	BKR6EK	20
Z 118	BP5HS	
Z 121	BKUR5ET-10	
Z 122	IFR5D10	
Z 144	BUR6EFSZ	
Z 145	BKR6EKUB	



BERU	→ NGK	V-Line
Z 148	TR55IX	
Z 149	BCPR6EP-11	
Z 150	BCPR6EP-11	
Z 151	BKR6EP-8	
Z 152	BCRE527Y	
Z 153	BKR5EY	
Z 154	BKR5EYA	
Z 155	BKR6EY	
Z 156	BKR6EYA	
Z 157	BKR6EYA-11	
Z 158	ZFR6F-11	
Z 170	IFR6D10	
Z 171	IFR6D10	
Z 176	PZFR5D-11	34
Z 177	PTR5A-13	25
Z 183	LFR5B	46
Z 184	LFR6B	47
Z 185	PFR7Q	
Z 188	PFR6Q	37
Z 194	BKR6EKE	
Z 198	BKR7EKC	
Z 200	ZFR5P-G	41
Z 203	ZFR5F	53
Z 213	BKR6EKUE	
Z 216	LZTR4A-11	
Z 222	LTR6B-10T	
Z 226	ILFR6A	
Z 227	BKR6EZB	
Z 233	PLZKBR7B8G	
Z 236	PZFR5N-11T	
Z 237	BKR6EQUP	30
Z 240	PFR5R-11	
Z 243	LZKAR7A	54
Z 245	BKR6EKC	26
Z 246	BKUR5ET	29
Z 249	BKR5EYA-11	39
Z 272	ZFR6T-11G	44
Z 272SB	ZFR6T-11G	44
Z 273	LFR6C-11	48
Z 273SB	LFR6C-11	48
Z 274	ILKAR7A7	
Z 278	IZFR5B	
Z 279	IZFR6B	
Z 282	IFR6D10	
Z 286	LKR8A	
Z 286SB	LKR8A	
Z 288	PLZKBR7B8G	
Z 291	DCPR8E-N	
Z 292	DCPR7E-N-10	43
Z 293	ZKR7A-10	42
Z 294	LFR6D	
Z 299	ZFR6K-11	

BERU	→ NGK	V-Line
Z 301	IZFR6H11	
Z 306	IZKR7B	
Z 307	IFR5E13	
Z 308	LKR7B-9	
Z 310	ILTR6A-13G	
Z 311	PGR5C-11	
Z 325	PLZKAR6A-11	51
Z 326	PLFR6A	
Z 332	PLZKBR7B8G	
Z 333	IKR6G11	
Z 336	PLZKBR7B8G	
Z 346	ZFR6BP-G	
Z 347	PFR7S8EG	50
Z 349	PZFR6R	52
Z 349SB	PZFR6R	52
Z 355	ILZKAR7A10	
Z 361	LKR6D-10E	
Z 362	LZKR6B-10E	49
Z 366	SILZKGR8B8S	
Z 369	LZKAR6AP-11	
Z 370	ILKAR7L11	
Z 374	ILKAR7D6G	
Z 375	BKR7EQUP	
Z 376	ILNAR8B7G	
Z 378	IZFR6P7	
Z 379	ILKAR7J7G	
Z 381	LZKR6AI-10G	
Z 382	IFR7X7G	
BOSCH	→ NGK	V-Line
+1	BPR6ES	2
+2	BUR6ET	1
+3	BPR5ES	6
+4	BUR5ET-10	21
+5	BPR6EFS	7
+6	BKR5ES	35
+7	BKR6EKC	26
+8	BKR6ES	28
+9	BKR5EK	23
+10	BPR6HS	3
+11	BKR6ES-11	14
+12	BPR6ES	2
+13	BKR6ES	28
+14	BPR5EFS	
+15	BPR7ES	19
+16	BPR5ES	6
+17	PTR5A-13	25
+18	BPR6EFS	7
+19	BKR5ES-11	33
+20	BPR5HS	
+21	BPR6ES-11	13
+22	BPR5ES-11	
+23	BKR6EKUB	



BOSCH	→ NGK	V-Line
+24	PFR6B	
+25	BPR4FS	
+26	TR55	
+27	BPR5ES-11	
+31	BKR6EY-11	
+32	ZFR6F-11	
+33	BPR4FS-15	
+34	ZGR5A	15
+36	BKR5EKB-11	
+39	TR5B-13	45
+41	ZKR7A-10	42
+42	LFR6B	47
+44	BKUR5ET-10	
+45	PFR5R-11	
+46	BPR6EFS-13	
+47	BKR6EY	
+48	BKR6EQUJ	30
+50	PFR6Q	37
+51	ZFR6T-11G	44
+52	PZFR5D-11	34
+53	BKR6EZ	38
0 241 145 515	PZKER7B8EGS	55
0 241 145 523	PKER7A8DES	
0 241 145 523	PKER7A8DES	
0 241 219 537	BP4FS	
0 241 219 542	BP4ES	
0 241 219 554	B-4	
0 241 219 555	BP4ES	
0 241 225 013	BP5ES	8
0 241 225 543	BP4FS	
0 241 225 545	BP5ES	8
0 241 225 548	B-4	
0 241 225 549	B5HS	
0 241 225 550	BP5ES	8
0 241 225 555	BPR4FS-15	
0 241 225 556	BP5ES	8
0 241 225 558	BP5EFS	
0 241 225 573	BP5EFS	
0 241 225 574	BCPR4ES-11	
0 241 225 576	BP5ET	
0 241 225 582	BP5ES-11	
0 241 225 585	ZGR5A	15
0 241 225 593	BP5ES	8
0 241 229 059	ZGR5A	15
0 241 229 060	BP5ET-10	
0 241 229 061	BP5ES	8
0 241 229 062	BP5ES	8
0 241 229 574	BP5ES	8
0 241 229 578	BP5HS	
0 241 229 579	B5ES	
0 241 229 580	B6S	
0 241 229 588	BP5ES	8

BOSCH	→ NGK	V-Line
0 241 229 594	BP5FS	
0 241 229 596	BP5ES-11	
0 241 229 604	B5HS	
0 241 229 612	B5HS	
0 241 229 617	BP5EFS	
0 241 229 619	BP5ET	
0 241 229 634	BCP5ES	16
0 241 229 639	ZFR5F	53
0 241 229 641	BP5HS	
0 241 229 649	BP5EFS	
0 241 229 657	ZFR5F	53
0 241 229 661	BUR6ET	1
0 241 229 663	BUR5ET-10	21
0 241 229 665	BUR5ET	22
0 241 229 666	BKR6EK	20
0 241 229 676	BKUR5ET	29
0 241 229 682	BCP5ES-11	
0 241 229 684	BKR5ES	35
0 241 229 704	IFR5D10	
0 241 229 712	BCP5ES	16
0 241 229 713	BCP5ES	16
0 241 229 714	BP5HS	
0 241 229 715	BP5ES	8
0 241 229 716	BP5ET	
0 241 229 926	BP5ES	8
0 241 235 089	B6ES	
0 241 235 098	B6ES	
0 241 235 099	BPR6ES	2
0 241 235 103	BP6ESZ	
0 241 235 108	BCP6ET	
0 241 235 563	BP6ES	4
0 241 235 564	BP6HS	18
0 241 235 574	B6ES	
0 241 235 594	B6S	
0 241 235 602	BP6ES	4
0 241 235 610	BP6ES-11	
0 241 235 633	BUR6ET	1
0 241 235 635	BP6EFS	5
0 241 235 636	BP6EFS	5
0 241 235 638	BR6EF	
0 241 235 643	BUR6ET	1
0 241 235 646	BP6EFS-13	
0 241 235 668	BP6EFS	5
0 241 235 673	BCP6ES	17
0 241 235 674	ZFR6A-11	
0 241 235 676	BCP6ES	17
0 241 235 681	BP6EFS	5
0 241 235 685	BCP6ES-11	
0 241 235 690	BKR6EK	20
0 241 235 692	ZFR6F-11	
0 241 235 693	BP6ESZ	
0 241 235 698	BUR6ET	1



BOSCH	→ NGK	V-Line
0 241 235 705	BP6ESZ	
0 241 235 706	BKUR6ET-10	24
0 241 235 715	PZFR5D-11	34
0 241 235 735	ZFR5P-G	41
0 241 235 736	BKR6ES	28
0 241 235 739	IFR6D10	
0 241 235 750	BCP6ES	17
0 241 235 751	BKR6EK	20
0 241 235 752	BKUR6ET-10	24
0 241 235 753	BP6EFS	5
0 241 235 754	BP6HS	18
0 241 235 755	BP6ES	4
0 241 235 756	BUR6ET	1
0 241 235 757	BUR6ET	1
0 241 240 057	BP6ESZ	
0 241 240 058	BP6ESZ	
0 241 240 524	BP6EFS	5
0 241 240 530	BP6ES	4
0 241 240 532	BP6HS	18
0 241 240 539	BP6ES	4
0 241 240 542	BCP6ES	17
0 241 240 543	BP6FS	
0 241 240 558	BUR6ET	1
0 241 240 563	BP6EFS	5
0 241 240 564	BCP6ET	
0 241 240 569	BCP6ES-11	
0 241 240 574	BP6ES-11	
0 241 240 578	BP6EFS	5
0 241 240 585	BKR6EIX	
0 241 240 587	BKR6ES	28
0 241 240 592	BKUR7ET	
0 241 240 603	B6HS	
0 241 240 608	BCP6ES	17
0 241 240 609	BCP6ET	
0 241 240 611	BP6ES	4
0 241 240 631	ILFR6A	
0 241 243 501	BPR6EIX	
0 241 245 070	BUR6ET	1
0 241 245 552	BP7ES	
0 241 245 553	BP7HS	
0 241 245 570	BP7EFS	
0 241 245 574	BR7HIX	
0 241 245 575	BR7EIX	
0 241 245 580	B7HS	
0 241 245 581	B7ES	
0 241 245 592	B7S	
0 241 245 599	BP7ES	
0 241 245 602	B7HS	
0 241 245 603	B7ES	
0 241 245 619	BP7HS	
0 241 245 636	BP7EFS	
0 241 245 641	PFR7B	

BOSCH	→ NGK	V-Line
0 241 245 642	BCP7ES	
0 241 245 655	BCP7ES	
0 241 245 656	BP7HS	
0 241 245 673	PLFER7A8EG	
0 241 247 500	BPR7EIX	
0 241 248 531	B8HS	
0 241 248 534	B8ES	
0 241 248 538	B8ES	
0 241 248 540	B8HS	
0 241 250 502	BPR8EIX	
0 241 250 512	BPR8EIX	
0 241 250 526	R7433-8	
0 241 252 521	BR8HIX	
0 241 252 522	BR8EIX	
0 241 255 505	B8EFS	
0 241 255 507	R7433-9	
0 241 256 512	B8HS	
0 241 256 513	B9ES	
0 241 256 514	BR8HIX	
0 241 256 515	BR9EIX	
0 241 256 517	BPR8EIX	
0 241 256 519	B8HS	
0 241 256 522	B9ES	
0 241 260 507	B9HS	
0 241 260 510	B9EFS	
0 241 260 512	R7433-9	
0 241 262 506	BR10EIX	
0 241 268 506	BR10EIX	
0 241 274 505	BR10EIX	
0 241 280 503	BR10EIX	
0 241 309 501	AP5FS	
0 241 319 510	AP5FS	
0 241 319 512	AB-6	
0 241 319 513	AB-6	
0 241 325 509	AP5FS	
0 241 329 520	AP5FS	
0 241 329 525	AB-6	
0 241 329 526	AB-6	
0 241 335 516	AP6FS	
0 241 335 520	A6FS	
0 241 335 524	AB-7	
0 241 335 526	AB-7	
0 241 335 528	AP6FS	
0 241 340 501	AP6FS	
0 241 345 512	AB-7	
0 241 350 505	AB-7	
0 242 129 503	LZKAR7A	54
0 242 129 508	LZKAR7A	54
0 242 129 512	PLZKBR7B8G	
0 242 129 515	LZKR6B-10E	49
0 242 129 515	LZKR6B-10E	
0 242 129 524	SILZKR6B10E	



BOSCH	→ NGK	V-Line
0 242 129 526	DILKR6A11	
0 242 129 804	PLZKBR7B8G	
0 242 135 501	DCPR8E-N	
0 242 135 509	PLKR7A	
0 242 135 515	ZKR7A-10	42
0 242 135 518	PLZKBR7B8G	
0 242 135 524	PLZKAR6A-11	51
0 242 135 524	PLZKAR6A-11	
0 242 135 531	DILKAR7E11HS	
0 242 135 554	SILKR6C10E	
0 242 135 557	DILZKR7B11GS	
0 242 135 563	ZKR7BI-10	
0 242 140 504	DCPR8EKC	
0 242 140 512	PLKR7B8E	
0 242 140 528	ILZKR7A	
0 242 140 536	DILKAR7E9HS	
0 242 140 550	DILKAR7G11GS	
0 242 140 550	DILKAR7G11GS	
0 242 140 555	DILKAR7G11GS	
0 242 140 555	DILKAR7G11GS	
0 242 140 557	ILKAR8H6	
0 242 145 503	DCPR8EKC	
0 242 145 517	SILZKBR8D8S	
0 242 145 584	SILNAR7B7	
0 242 219 511	BPR4FS-15	
0 242 219 516	BPR4FS	
0 242 219 517	BPR4FS-11	
0 242 219 519	BCPR4ES-11	
0 242 219 529	ZGR5B	
0 242 219 530	BPR4ES-13	
0 242 225 523	BR5ES	
0 242 225 524	BPR5ES	6
0 242 225 525	BPR5ES-13	
0 242 225 528	ZGR5C	
0 242 225 531	BPR4FS	
0 242 225 532	BPR4FS-15	
0 242 225 533	BPR5EFS	
0 242 225 534	BPR5EFS-13	
0 242 225 537	ZFR4F-11	
0 242 225 538	BPR5EIX	
0 242 225 539	ZGR5A	15
0 242 225 548	BPR5ES-11	
0 242 225 549	BCPR4ES-11	
0 242 225 550	BPR5ES	6
0 242 225 553	BPR5ES	6
0 242 225 554	BPR5ES-11	
0 242 225 560	BPR4FS-11	
0 242 225 566	BPR4FS-15	
0 242 225 571	TR5IX	
0 242 225 573	BPR4FS	
0 242 225 578	TR55IX	
0 242 225 582	BKR5ES	35

BOSCH	→ NGK	V-Line
0 242 225 599	BPR5ES	6
0 242 225 622	BPR4FS	
0 242 225 623	TR55	
0 242 225 624	BPR5ES-11	
0 242 225 641	BPR4FS-15	
0 242 225 859	BPR5ES	6
0 242 225 861	BPR5ES	6
0 242 229 529	BPR5FS-15	
0 242 229 530	BKR5ES-11	33
0 242 229 531	BPR5ES	6
0 242 229 533	BR5ES	
0 242 229 537	BPR5EIX	
0 242 229 538	BPR5ES	6
0 242 229 543	BKR5ES-11	33
0 242 229 544	ZFR5F-11	40
0 242 229 549	BPR5FS-11	
0 242 229 555	BPR5ES	6
0 242 229 556	BR5ES	
0 242 229 557	BPR5ES-11	
0 242 229 566	BPR5ES-11	
0 242 229 568	BKR5ES	35
0 242 229 570	BPR5ES	6
0 242 229 576	ZFR6F-11	
0 242 229 587	BKR5ES	35
0 242 229 589	BPR5HS	
0 242 229 591	BKR5EK	23
0 242 229 594	BKR5ES	35
0 242 229 598	BKR5EIX	
0 242 229 605	BKR5EK	23
0 242 229 607	BPR5ES	6
0 242 229 610	BPR5HS	
0 242 229 613	BKR5EKUP	
0 242 229 625	BKUR5ET-10	
0 242 229 626	BKR5EK	23
0 242 229 628	BKR5EK	23
0 242 229 630	LFR5B	46
0 242 229 634	PLFR5A-11	
0 242 229 635	BKR5EYA-11	39
0 242 229 641	PTR5D-10	31
0 242 229 648	BKR5EQUA	
0 242 229 650	TR5B-13	45
0 242 229 654	BKR5EK	23
0 242 229 655	BPR5EFS	
0 242 229 656	BPR5ES	6
0 242 229 657	BPR5HS	
0 242 229 658	BUR5ET-10	21
0 242 229 659	BKR5ES	35
0 242 229 660	BKR5ES-11	33
0 242 229 661	LTR6B-10T	
0 242 229 671	BKR5EKB-11	
0 242 229 673	BKR5ES	35
0 242 229 687	BPR5ES-11	



BOSCH	→ NGK	V-Line
0 242 229 699	ZFR5F	53
0 242 229 706	BKUR5ET-10	
0 242 229 708	ILFR5B11	
0 242 229 713	PFR5R-11	
0 242 229 724	BKR6EZB	
0 242 229 779	ZGR5A	15
0 242 229 781	BKR5EKB-11	
0 242 229 782	BKR5EKB-11	
0 242 229 785	TR5B-13	45
0 242 229 797	LFR6B	47
0 242 229 799	BKUR5ET-10	
0 242 229 878	BKR5EK	23
0 242 229 879	BPR5EFS	
0 242 229 880	BPR5ES	6
0 242 229 881	BPR5HS	
0 242 229 882	BUR5ET-10	21
0 242 229 883	BKR5ES	35
0 242 229 884	BKR5ES-11	33
0 242 229 885	BPR5ES-11	
0 242 229 887	BKR5EK	23
0 242 229 888	BKR5ES	35
0 242 229 902	TR5B-13	45
0 242 229 923	LFR6B	47
0 242 229 925	PFR5R-11	
0 242 229 982	BPR5ES	6
0 242 230 500	PFR5R-11	
0 242 230 571	LZFR5CI-11	
0 242 230 618	LZFR5CI-11	
0 242 230 624	LZFR5CI-11	
0 242 230 806	ZFR5F	53
0 242 235 511	BPR6ES	2
0 242 235 522	BPR6HS	3
0 242 235 525	BPR6EIX	
0 242 235 529	BPR6ES	2
0 242 235 530	BPR6ES-11	13
0 242 235 532	BR6ES	
0 242 235 535	BPR6HS	3
0 242 235 537	BPR6ES	2
0 242 235 538	BPR6EFS	7
0 242 235 541	BPR6EIX	
0 242 235 542	BPR6EFS	7
0 242 235 543	BR6ES-11	
0 242 235 544	BKR6ES-11	14
0 242 235 545	BR6ES-11	
0 242 235 546	BR6ES	
0 242 235 547	BKR6ES-11	14
0 242 235 551	BKR6ES	28
0 242 235 556	BKR6ES	28
0 242 235 564	BCPR6ET	
0 242 235 567	ZFR6F-11	
0 242 235 571	BUR6ET	1
0 242 235 579	BKR6ES	28

BOSCH	→ NGK	V-Line
0 242 235 587	BKR6ES	28
0 242 235 588	BKR6ES	28
0 242 235 589	BKR6EK	20
0 242 235 590	BUR6ET	1
0 242 235 592	BPR6EFS-13	
0 242 235 597	BKR6ES	28
0 242 235 599	BKR6EY	
0 242 235 602	BKR6EY-11	
0 242 235 605	BKR6EK	20
0 242 235 607	BUR6EFSZ	
0 242 235 609	BKR6EZ	38
0 242 235 610	BKR6EP-13	
0 242 235 616	BKR6ES	28
0 242 235 617	BKR6EQUF	30
0 242 235 624	BKR6ES	28
0 242 235 630	BPR6ES	2
0 242 235 640	BKR6EZ	38
0 242 235 642	BKR6EKUB	
0 242 235 656	BKR6EQUF	30
0 242 235 659	BKR6EYA-11	
0 242 235 661	BPR6EFS	7
0 242 235 662	PTR5A-13	25
0 242 235 663	BPR6ES	2
0 242 235 664	BUR6ET	1
0 242 235 665	BPR6HS	3
0 242 235 666	BKR6ES	28
0 242 235 667	BKR6ES-11	14
0 242 235 668	BKR6EKC	26
0 242 235 690	PFR6N-11	
0 242 235 692	ZFR5E-11	
0 242 235 699	BKR6EIX	
0 242 235 707	BPR6ES-11	13
0 242 235 715	BKR6EQUA	
0 242 235 740	PFR6Q	37
0 242 235 743	PLFR6A	
0 242 235 748	BKR6EKUB	
0 242 235 749	PFR6B	
0 242 235 761	ZFR5P-G	41
0 242 235 767	PTR5A-13	25
0 242 235 769	ILZFR6C-11K	
0 242 235 776	IZFR6H11	
0 242 235 908	BPR6EFS	7
0 242 235 909	BPR6ES	2
0 242 235 910	BUR6ET	1
0 242 235 911	BPR6HS	3
0 242 235 912	BKR6ES	28
0 242 235 913	BKR6ES-11	14
0 242 235 914	BKR6EKC	26
0 242 235 915	BPR6ES-11	13
0 242 235 916	PTR5A-13	25
0 242 235 917	BKR6EKUB	
0 242 235 918	PFR6B	



BOSCH	→ NGK	V-Line
0 242 235 925	BKR6ES	28
0 242 235 930	BPR6ES	2
0 242 235 931	BUR6ET	1
0 242 235 979	BPR6EFS-13	
0 242 235 980	BKR6EY	
0 242 235 981	BKR6EQUP	30
0 242 235 982	PFR6Q	37
0 242 235 983	ZFR6T-11G	44
0 242 235 984	PZFR5D-11	34
0 242 235 985	BKR6EY-11	
0 242 235 986	ZFR6F-11	
0 242 236 510	ILZFR6D11	
0 242 236 528	ILFR6B	
0 242 236 541	BKR6EY-11	
0 242 236 542	ZFR6F-11	
0 242 236 560	BPR6EFS-13	
0 242 236 561	BKR6EY	
0 242 236 562	BKR6EQUP	30
0 242 236 564	PFR6Q	37
0 242 236 565	ZFR6T-11G	44
0 242 236 566	PZFR5D-11	34
0 242 236 571	LPG1	
0 242 236 577	ILFR6K8	
0 242 236 583	PFR6X-11	
0 242 236 653	LZFR6AP11GS	
0 242 236 663	ILTR6E11	
0 242 236 665	LFR6C-11	48
0 242 236 665	LFR6C-11	
0 242 236 670	DIFR5C	
0 242 236 673	DILFR6A11	
0 242 240 511	BPR6ES	2
0 242 240 514	BPR6EFS	7
0 242 240 516	BPR6EIX	
0 242 240 519	BPR6EFS	7
0 242 240 520	BPR6FS	
0 242 240 521	BPR6ES	2
0 242 240 522	BPR6EFS	7
0 242 240 526	BKR6ES	28
0 242 240 528	BCPR6ET	
0 242 240 530	BKR6ES	28
0 242 240 531	BPR6ES-11	13
0 242 240 532	BPR6ES-11	13
0 242 240 533	BKR6ES-11	14
0 242 240 539	BKR6ES-11	14
0 242 240 546	BUR6ET	1
0 242 240 547	BKR5EKC	
0 242 240 557	BKR6EK	20
0 242 240 561	BPR6HS	3
0 242 240 562	BKR6EZ	38
0 242 240 564	BKR7EKC	
0 242 240 565	BKR7EKC	
0 242 240 566	BKR6EK	20

BOSCH	→ NGK	V-Line
0 242 240 569	BUR6EFSZ	
0 242 240 572	BKUR6ET	27
0 242 240 579	BPR6ES	2
0 242 240 584	BKR6EKE	
0 242 240 587	BKR6EQUP	30
0 242 240 590	ZFR6S-Q	
0 242 240 591	BPR6EFS	7
0 242 240 592	BPR6ES	2
0 242 240 593	BKR6ES	28
0 242 240 605	BKR6ES	28
0 242 240 619	ILFR6A	
0 242 240 648	BKR6EZ	38
0 242 240 653	LPG1	
0 242 240 665	PZFR6R	52
0 242 240 848	BPR6EFS	7
0 242 240 849	BPR6ES	2
0 242 240 850	BKR6ES	28
0 242 240 851	BKR6ES	28
0 242 245 015	BPR7EIX	
0 242 245 018	BKR7EKC	
0 242 245 514	BPR7EIX	
0 242 245 515	BCPR7ES	
0 242 245 517	BR7HS	
0 242 245 519	BPR7ES	19
0 242 245 520	BCPR7ES	
0 242 245 521	BR7ES	
0 242 245 536	BCPR7ES	
0 242 245 537	BPR7ES	19
0 242 245 539	BCPR7ET	
0 242 245 550	BCPR7ES-11	
0 242 245 552	BPR7ES	19
0 242 245 557	BR7ES	
0 242 245 559	BKR7EQUP	
0 242 245 571	LPG1	
0 242 245 576	PFR7S8EG	50
0 242 245 812	BPR7ES	19
0 242 250 503	BR8ES	
0 242 250 517	BR8EIX	
0 242 255 501	BR9ET	
0 242 255 504	BR9EIX	
0 242 319 501	APR5FS	
0 242 325 501	APR5FS	
0 242 329 503	APR5FS	
0 242 335 504	APR6FS	
0 242 340 501	APR6FS	
877 1207	R2349-10	
888 1101	R2349-11	
AR 5 NII 332	SILNAR7B7	
D 10 BC	AP5FS	
D 6 BC	AP6FS	
D 7 AC	A6FS	
D 7 BC	AP6FS	





BOSCH	→ NGK	V-Line
D 8 BC	AP5FS	
D 9 BC	AP5FS	
DR 10 BC	APR5FS	
DR 6 BC	APR6FS	
DR 7 BC	APR6FS	
DR 8 BC	APR5FS	
DR 9 BC	APR5FS	
F 000 KE0 017	BKUR6ET-10	24
F 000 KE0 P34	BPR6ES	2
F 000 KE0 P40	BKR6ES-11	14
F 000 KE0 P41	BKR5ES-11	33
F 03 DAR	BKR6EK	20
F 04 DAR	BKR6EK	20
F 2 CS	R7433-9	
F 2 DTC	R7433-9	
F 3 CS	R7433-9	
F 4 CS	R7433-8	
F 5 DC	BCP7ES	
F 5 DP 0 R	PFR7B	
F 5 DTC	BCP7ET	
F 5 KPP 332SB	PFR7S8EG	50
F 5KP P33 2GF	PFR8S8EG	
F 6 DC	BCP6ES	17
F 6 DC 0	BCP6ES	17
F 6 DCOR	BKR6ES	28
F 6 DCX	BCP6ES-11	
F 6 DPOR	PFR6Q	37
F 6 DSR	BKR6EIX	
F 6 DTC	BCP6ET	
F 6 KPP 332 S	PFR6Q	37
F 6 LTCR	BKUR7ET	
F 6 MPP 332	ILFR6A	
F 7 DC	BCP6ES	17
F 7 DC 0	BCP6ES	17
F 7 DCOR	BKR6ES	28
F 7 DCX	BCP6ES-11	
F 7 DER	BKR6ES	28
F 7 DPER	PFR6G-11	
F 7 DPP 332	IFR6D10	
F 7 DTC	BCP6ET	
F 7 HER 02	ZFR6T-11G	44
F 7 HER 2	ZFR5P-G	41
F 7 HPP 22	PFR6Q	37
F 7 HPP 222	PZFR5D-11	34
F 7 HPP 222U	PZFR6J-11	
F 7 HPPRX	PZFR5D-11	34
F 7 KTCR	BKUR6ET-10	24
F 7 LCOR 2	ZFR6F-11	
F 7 LCR	ZFR6A-11	
F 7 LDCR	BKR6EK	20
F 7 LTCR	BKUR6ET-10	24
F 8 DC	BCP5ES	16

BOSCH	→ NGK	V-Line
F 8 DC 0	BCP5ES	16
F 8 DC 4	BCP5ES	16
F 8 DCOR	BKR5ES	35
F 8 DCX	BCP5ES-11	
F 8 DPER	IFR5D10	
F 8 DPP 332	IFR5D10	
F 8 KTCR	BKUR5ET	29
F 8 LCR	ZFR5F	53
F 8 LCR 2	ZFR5F	53
F 8 LDCR	BKR6EK	20
F 9 DC 0	BCPR4ES-11	
F 9 LCR	ZFR4F-11	
FGR 5 KQE 0	BKR7EQUP	
FGR 6 HQE 0	ZFR6S-Q	
FGR 6 KQC	BKR6EQUP	30
FGR 6 KQE	BKR6EQUP	30
FGR 7 DPP 10	BKR6EIX-11P	
FGR 7 DQE+	BKR6EKUB	
FGR 7 DQE0	BKR6EKUB	
FGR 7 DQP	BKR6EQUP	30
FGR 7 DQP+	BKR6EQUP	30
FGR 7 KQC	BKR6EQUP	30
FGR 7 KQE	BKR6EQUP	30
FGR 7 KQE 0	BKR6EQUA	
FGR 8 KQE	BKR5EKUP	
FGR 8 KQE 0	BKR5EQUPA	
FGR 8 MQPE	PLFR5A-11	
FLR 8 LDCU	BKR5EK	23
FLR 8 LDCU+	BKR5EK	23
FQ 5 NIPP 332 S	PLFER7A8EG	
FQ 5 NPP 332 S	PLFER7A8EG	
FQR 8 DE	BKR6EZB	
FQR 8 LEU 2	ZFR5F	53
FR 10 DCX	BCPR4ES-11	
FR 5 DC	BCPR7ES	
FR 5 DCX	BCPR7ES-11	
FR 5 DTC	BCPR7ET	
FR 5 KPP 332 S	PFR7S8EG	50
FR 5 LDC	BKR7EKC	
FR 6 D 133	IFR6J11	
FR 6 DC	BKR6ES	28
FR 6 DC 0	BKR6EK	20
FR 6 DC 2	BKR6ES	28
FR 6 DC+	BKR6ES	28
FR 6 DCX	BKR6ES-11	14
FR 6 DDC	BKR7EKC	
FR 6 DTC	BCPR6ET	
FR 6 DTCW	BKR5EKC	
FR 6 HI 332	PZFR6R	52
FR 6 KDC	BKR6EZ	38
FR 6 KDC+	BKR6EZ	38
FR 6 KDE 0	BKR6EKE	



BOSCH	→ NGK	V-Line
FR 6 KTC	BKUR6ET	27
FR 6 LDC	BKR6EK	20
FR 6 MPP 10	PLFR6A-11	
FR 6 MPP 332	ILFR6A	
FR 7 DC	BKR6ES	28
FR 7 DC 0	BKR6ES	28
FR 7 DC 2	BKR6ES	28
FR 7 DC 4	BKR6ES	28
FR 7 DC+	BKR6ES	28
FR 7 DCX	BKR6ES-11	14
FR 7 DCX+	BKR6ES-11	14
FR 7 DE	BKR6EZ	38
FR 7 DPP 10	BKR6EIX	
FR 7 DPP 22U	PFR6N-11	
FR 7 DPP 33	PFR6Q	37
FR 7 DPP+	PFR6B	
FR 7 DQP	BKR6EQUF	30
FR 7 DTC	BCPR6ET	
FR 7 HC 0 X	ZFR5E-11	
FR 7 HC+	ZFR6T-11G	44
FR 7 HE 2	ZFR5P-G	41
FR 7 HPP 33+	PZFR5D-11	34
FR 7 KC	BKR6EY	
FR 7 KC+	BKR6EY	
FR 7 KCU	BKR6EYA-11	
FR 7 KCW	BKR6EP-13	
FR 7 KCX	BKR6EY-11	
FR 7 KCX+	BKR6EY-11	
FR 7 KDC	BKR6EZ	38
FR 7 KI30	FR6EI	
FR 7 KPP 33+	PFR6Q	37
FR 7 KPP 332	IZFR6H11	
FR 7 KPP 332 U	PFR6X-11	
FR 7 LC 2	BKR6ES	28
FR 7 LCX	ZFR6F-11	
FR 7 LCX+	ZFR6F-11	
FR 7 LDC	BKR6EK	20
FR 7 LDC+	BKR6EKC	26
FR 7 LDU	BKR6EK	20
FR 7 MPP 10	PLFR6A	
FR 7 NEU	LFR6C-11	48
FR 7 NEU	LFR6C-11	
FR 7 NI 33	ILFR6B	
FR 7 NI 332S	ILFR6K8	
FR 7 NII 352 U	DILFR6A11	
FR 7 NPP 332	ILZFR6D11	
FR 7 SI 30	ILZFR6C-11K	
FR 7 SPP 302 U	LZFR6AP11GS	
FR 8 DC	BKR5ES	35
FR 8 DC 0	BKR5ES	35
FR 8 DC+	BKR5ES	35
FR 8 DCX	BKR5ES-11	33

BOSCH	→ NGK	V-Line
FR 8 DCX+	BKR5ES-11	33
FR 8 DE	BKR5ES	35
FR 8 DPP 33	PFR5R-11	
FR 8 DPP 33+	PFR5R-11	
FR 8 DS	BKR5EIX	
FR 8 DX	BKR5ES-11	33
FR 8 HDC	BKR5EKB-11	
FR 8 HDC+	BKR5EKB-11	
FR 8 KCU	BKR5EYA-11	39
FR 8 KDC	BKR5EK	23
FR 8 KTC	BKUR5ET-10	
FR 8 KTC+	BKUR5ET-10	
FR 8 LCX	ZFR6F-11	
FR 8 LDC	BKR5EK	23
FR 8 LDC 4	BKR5EK	23
FR 8 LTC	BKUR5ET-10	
FR 8 ME	LFR5B	46
FR 8 SC+	LFR6B	47
FR 8 SPP 332	ILFR5B11	
FR 9 DC	BKR5ES	35
FR 9 DCX	BCPR4ES-11	
FR 9 HC	ZFR4F-11	
FR 7 KII35T	DIFR5C	
FR 8 SEX	LZFR5CI-11	
FR 8 SII332X	LZFR5CI-11	
FR 8 SII33X	LZFR5CI-11	
H 10 BC	BP4FS	
H 10 C	BP4FS	
H 2 CS	B9EFS	
H 3 CS	B8EFS	
H 5 DC	BP7EFS	
H 5 DC 0	BP7EFS	
H 6 BC	BP6FS	
H 6 DC	BP6EFS	5
H 6 DC 0	BP6EFS	5
H 7 CC	BR6EF	
H 7 DC	BP6EFS	5
H 7 DC 0	BP6EFS	5
H 7 DCY	BP6EFS-13	
H 8 BC	BP5FS	
H 8 DC	BP5EFS	
H 8 DC 0	BP5EFS	
H 8 DCX	BP5EFS-13	
H 9 BC	BP4FS	
H 9 BCY	BPR4FS-15	
H 9 DC	BP5EFS	
H 9 DC0	BP5EFS	
HGR 6 KQC	BUR6EFSZ	
HGR 7 KQC	BUR6EFSZ	
HLR 8 STEX	LTR6B-10T	
HR 10 BC	BPR4FS	
HR 10 BCX	BPR4FS-11	





BOSCH	→ NGK	V-Line
HR 10 BCY	BPR4FS-15	
HR 6 BC	BPR6FS	
HR 6 DC	BPR6EFS	7
HR 6 DC+	BPR6EFS	7
HR 6 DS	BPR6EFS	7
HR 7 DC	BPR6EFS	7
HR 7 DC+	BPR6EFS	7
HR 7 DCX	BPR6EFS-13	
HR 7 DCX+	BPR6EFS-13	
HR 7 MPP 302	PTR5A-13	25
HR 7 MPP 302 X	PTR5A-13	25
HR 7 MPP+	PTR5A-13	25
HR 7 NII 332 W	ILTR6E11	
HR 8 BCY	BPR5FS-15	
HR 8 DC+	BPR5EFS	
HR 8 DPP 22U	PTR5D-10	31
HR 8 LCO	TR5-1	
HR 8 MCV+	TR5B-13	45
HR 8 MEV	TR5B-13	45
HR 9 BC	BPR4FS	
HR 9 BC+	BPR4FS	
HR 9 BCY	BPR4FS-15	
HR 9 BCY+	BPR4FS-15	
HR 9 DC	BPR5EFS	
HR 9 DCX	BPR5EFS-13	
HR 9 DCY+	TR55	
M 10 AC	AB-6	
M 10 AC0	AB-6	
M 12 B	AP5FS	
M 4 AC	AB-7	
M 5 AC	AB-7	
M 7 AC	AB-7	
M 8 AC	AB-6	
M 8 AC0	AB-6	
VR 6 NII 332	ILKAR8H6	
VR 6 NII 35 U	DILKAR7G11GS	
VR 6 NII 352 U	DILKAR7G11GS	
VR 7 SPP 33	PLZKAR6A-11	51
VR 7 SPP 33	PLZKAR6A-11	
VR 7 TII 35 U	DILKAR7E11HS	
VR 8 SE	LZKAR7A	54
VR 8 SEW	LZKAR7A	54
VR6NII352U	DILKAR7G11GS	
VR6NII35T	DILKAR7E9HS	
VR6NII35U	DILKAR7G11GS	
W 2 A	B9HS	
W 2 AC	B9HS	
W 2 CS	BR10EIX	
W 2 D	BP9ES	
W 3 A	B8HS	
W 3 A 0	B8HS	
W 3 AC	B8HS	

BOSCH	→ NGK	V-Line
W 3 AP	B8HS	
W 3 AS	BR8HIX	
W 3 C	B9ES	
W 3 C0	B9ES	
W 3 CC	B9ES	
W 3 CP	B9ES	
W 3 CS	BR9EIX	
W 3 D	BP8ES	
W 3 DP	BPR8EIX	
W 3 DP 2	BP8ES	
W 3 DPO	BPR8EIX	
W 4 A	B8HS	
W 4 A 1	B8HS	
W 4 A 2	B8HS	
W 4 A 5	B8HS	
W 4 AC	B8HS	
W 4 AP	B8HS	
W 4 AS	BR8HIX	
W 4 C	B8ES	
W 4 C 1	B8ES	
W 4 C 2	B7ES	
W 4 C3	B7HS	
W 4 CC	B8ES	
W 4 CP	BR8EIX	
W 4 CPX	B8ES	
W 4 CS	BR8EIX	
W 4 DP	BPR7EIX	
W 4 DPO	BPR8EIX	
W 4 E2	B7S	
W 5 A	B7HS	
W 5 AC	B7HS	
W 5 AP	B7HS	
W 5 AS	BR7HIX	
W 5 B	BP7HS	
W 5 BC	BP7HS	
W 5 BP	BP7HS	
W 5 C	B7ES	
W 5 CC	B7ES	
W 5 CCX	B7ES-11	
W 5 CP	B7ES	
W 5 CPX	B7ES-11	
W 5 CS	BR7EIX	
W 5 D	BP7ES	
W 5 D1	BP7ES	
W 5 DC	BP7ES	
W 5 DC0	BP7ES	
W 5 DCX	BP7ES-11	
W 5 DP	BP7ES	
W 5 DPX	BP7ES-11	
W 5 DTC	BUR6ET	1
W 5 E	B7S	
W 5 EC	B7S	



BOSCH	→ NGK	V-Line
W 5 EP	B7S	
W 6 AC	B6HS	
W 6 B	BP6HS	18
W 6 BC	BP6HS	18
W 6 BP	BP6HS	18
W 06 CS	BR10EIX	
W 6 D	BP6ES	4
W 6 D1	BP6ES	4
W 6 DC	BP6ES	4
W 6 DC0	BP6ESZ	
W 6 DCX	BP6ES-11	
W 6 DP	BPR6EIX	
W 6 DPX	BPR6EIX-11	
W 6 DTC	BUR6ET	1
W 6 LTCR	BUR6ET	1
W 7 A	B6HS	
W 7 A0	B6HS	
W 7 AO0	B6HS	
W 7 AP	B6HS	
W 7 B	BP6HS	18
W 7 BC	BP6HS	18
W 7 BP	BP6HS	18
W 7 C	B6ES	
W 7 CC	B6ES	
W 7 CC0	B6ES	
W 7 CCX	B6ES-11	
W 7 CP	B6ES	
W 7 CPX	B6ES-11	
W 07 CS	BR10EIX	
W 7 CX	B6ES-11	
W 7 D	BP6ESZ	
W 7 D0	BP6ES	4
W 7 DC	BP6ES	4
W 7 DC0	BP6ESZ	
W 7 DCR	BPR6ES	2
W 7 DCX	BP6ES-11	
W 7 DP	BP6ES	4
W 7 DPX	BP6ES-11	
W 7 DTC	BUR6ET	1
W 7 DX	BP6ES-11	
W 7 E	B6S	
W 7 EC	B6S	
W 7 EP	B6S	
W 7 LTCR	BUR6ET	1
W 8 A	B5HS	
W 8 A0	B5HS	
W 8 AC	B5HS	
W 8 AP	B5HS	
W 8 B	BP5HS	
W 8 BC	BP5HS	
W 8 BP	BP5HS	
W 8 C	B5ES	

BOSCH	→ NGK	V-Line
W 8 C0	B5ES	
W 8 CC	B5ES	
W 8 CCX	B5ES	
W 8 CP	B5ES	
W 08 CS	BR10EIX	
W 8 D	BP5ES	8
W 8 DC	BP5ES	8
W 8 DC0	BP5ES	8
W 8 DCX	BP5ES-11	
W 8 DCY	BP5ES-13	
W 8 DP	BP5ES	8
W 8 DPX	BP5ES-11	
W 8 DTC	BP5ET	
W 8 DX	BP5ES-11	
W 8 E	B6S	
W 8 EC	B6S	
W 8 LCR	ZGR5A	15
W 8 LDCR	BUR6ET	1
W 8 LPR	ZGR5A	15
W 8 LTCR	BUR5ET-10	21
W 9 AC	B5HS	
W 9 AC0	B5HS	
W 9 D	BP5ES	8
W 9 DC	BP5ES	8
W 9 DC0	BP5ES	8
W 9 DCX	BP5ES-11	
W 9 DP	BP5ES	8
W 9 DPX	BP5ES-11	
W 9 DTC	BP5ET	
W 9 E	B-4	
W 9 EC	B-4	
W 9 LC	ZGR5A	15
W 10 D	BP4ES	
W 10 DC	BP4ES	
W 10 E	B-4	
W 10 EC	B-4	
W 45 T3	B-4	
W 95 T3	B-4	
W 95 T30	BP4ES	
W 125 T3	B-4	
W 125 T30	BP5ES	8
W 125 TR2	BR5ES	
W 125 TR30	BPR5ES	6
W 145 M1	B5HS	
W 145 M2	B5ES	
W 145 T1	B5HS	
W 145 T11	B5HS	
W 145 T2	B5ES	
W 145 T3	B6S	
W 145 T30	BP5ES	8
W 145 T35	BP5HS	
W 145 TR2	BR5ES	



BOSCH	→ NGK	V-Line
W 145 TR30	BPR5ES	6
W 160 T2	B6ES	
W 160 T30	BP5ES	8
W 175 T1	B6HS	
W 175 T2	B6ES	
W 175 T3	B6S	
W 175 T30	BP6ES	4
W 175 T35	BP6HS	18
W 175 T7	BP6HS	18
W 175 TR2	BR6ES	
W 175 TR30	BPR6ES	2
W 175 TR35	BPR6HS	3
W 175 Z1	B6HS	
W 190 M11S	BR6HIX	
W 200 T27	BP6ES	4
W 200 T30	BP6ES	4
W 200 T35	BP6HS	18
W 200 TR30	BPR6ES	2
W 215 P21	BPR7EIX	
W 215 T30	BP6ES	4
W 220 T30	BP6ES	4
W 225 S1S	BR7HIX	
W 225 S2S	BR7EIX	
W 225 T1	B7HS	
W 225 T2	B7ES	
W 225 T3	B7S	
W 225 T30	BP8ES	
W 225 T35	BP7HS	
W 225 T7	BPR7HS	
W 225 TR1	BR7HS	
W 225 TR2	BR7ES	
W 225 TR30	BPR7ES	19
W 230 T30	BP7ES	
W 235 P21	BP7ES	
W 235 T28	BP8ES	
W 240 M1	B8HS	
W 240 MZ1	B8HS	
W 240 T1	B8HS	
W 240 T2	B8ES	
W 240 T28	B8ES	
W 240 T3	B7S	
W 250 P21	BP7ES	
W 250 T1	B8HS	
W 250 T2	B8ES	
W 250 TR2	BR8ES	
W 255 T30	BP7ES	
W 260 M1	B8HS	
W 260 MZ1	B8HS	
W 260 MZ2	B9ES	
W 260 S1S	BR8HIX	
W 260 S2S	BR8EIX	
W 260 T1	B8HS	

BOSCH	→ NGK	V-Line
W 260 T2	B8ES	
W 260 T20	B8ES	
W 260 T30	BP8ES	
W 265 P21	BPR9EIX	
W 275 T1	B8HS	
W 275 T2	B9ES	
W 280 MZ1	B8HS	
W 280 MZ2	B9ES	
W 280 P21	BP8ES	
W 280 S2S	BR9EIX	
W 280 T30	BP8ES	
W 300 T1	B9HS	
W 300 T30	BP9ES	
W 310 S2S	BR10EIX	
W 330 T1	B9HS	
W 340 S2S	BR10EIX	
W 370 S2S	BR10EIX	
W 400 S2S	BR10EIX	
WA 125 T30	BP5EFS	
WA 125 T40	BP4FS	
WA 125 TR30	BPR5EFS	
WA 125 TR40	BPR4FS	
WA 145 T40	BP5FS	
WA 175 T30	BP6EFS	5
WA 200 T30	BP6EFS	5
WA 200 T40	BP6FS	
WA 200 TR30	BPR6EFS	7
WA 200 TR40	BPR6FS	
WA 225 T30	BP7EFS	
WA 95 T40	BP4FS	
WA 95 TR40	BPR4FS	
WG 235 T28	BP7ES	
WG 250 P21	BPR9EIX	
WG 250 T28	BPR8EIX	
WG 250 T30	BP8ES	
WG 265 T2SP	BPR9EIX	
WR 10 LC	ZGR5B	
WR 10 LCV	BPR4ES-13	
WR 3 CS	BR9EIX	
WR 3 CTC	BR9ET	
WR 4 CC	BR8ES	
WR 5 A	BR7HS	
WR 5 AC	BR7HS	
WR 5 C	BR7ES	
WR 5 CC	BR7ES	
WR 5 DC	BPR7ES	19
WR 5 DC+	BPR7ES	19
WR 5 DS	BPR7EIX	
WR 6 BC	BPR6HS	3
WR 6 DC	BPR6ES	2
WR 6 DC+	BPR6ES	2
WR 6 DCX	BPR6ES-11	13



BOSCH	→ NGK	V-Line
WR 6 DS	BPR6EIX	
WR 6 DTC	BUR6ET	1
WR 7 BC	BPR6HS	3
WR 7 BC+	BPR6HS	3
WR 7 C	BR6ES	
WR 7 CC	BR6ES	
WR 7 CCX	BR6ES-11	
WR 7 DC	BPR6ES	2
WR 7 DC+	BPR6ES	2
WR 7 DC2	BPR6ES	2
WR 7 DCX	BPR6ES-11	13
WR 7 DCX+	BPR6ES-11	13
WR 7 DS	BPR6EIX	
WR 7 DTC	BUR6ET	1
WR 7 LTC+	BUR6ET	1
WR 8 BC	BPR5HS	
WR 8 BC+	BPR5HS	
WR 8 C	BR5ES	
WR 8 CC	BR5ES	
WR 8 DC	BPR5ES	6
WR 8 DC+	BPR5ES	6
WR 8 DC0	BPR5ES	6
WR 8 DC4	BPR5ES	6
WR 8 DCX	BPR5ES-11	
WR 8 DCX+	BPR5ES-11	
WR 8 DPY	BPR5ES-13	
WR 8 DS	BPR5EIX	
WR 8 HP	ZGR5C	
WR 8 LC+	ZGR5A	15
WR 8 LTC+	BUR5ET-10	21
WR 9 C	BR5ES	
WR 9 CC	BR5ES	
WR 9 DC	BPR5ES	6
WR 9 DC+	BPR5ES	6
WR 9 DCX	BPR5ES-11	
WR 9 DCX+	BPR5ES-11	
WR 9 DCY	BPR5ES-13	
WR 9 DS	BPR5EIX	
WR 9 DY	BPR5ES-13	
WR 9 H	ZGR5C	
WR 9 HC	ZGR5C	
WR 9 HP	ZGR5C	
WR 9 LC	ZGR5A	15
WR 9 LS	ZGR5A	15
WR7BC4	BPR6HS	3
X 3 CP0	D9EA	
Y 5 KPP 332 S	PZKER7B8EGS	55
Y5KPP332	PKER7A8DES	
YR 5 LDE	DCPR8EKC	
YR 6 LDE	DCPR8EKC	
YR 6 NPP 332	PLKR7B8E	
YR 6 TII 330 T	ILZKR7A	

BOSCH	→ NGK	V-Line
YR 7 DC+	ZKR7A-10	42
YR 7 DE	DCPR8E-N	
YR 7 MII 33 X	SILKR6C10E	
YR 7 MPP 33	PLKR7A	
YR 8 SEU	LZKR6B-10E	49
YR 8 SEU	LZKR6B-10E	
YR7KII33T	ZKR7BI-10	
YR7SII3520X	DILZKR7B11GS	
YR8NII350	DILKR6A11	
YR8SII33U	SILZKR6B10E	
ZMR 5 TPP 33	SILZKBR8D8S	
ZQR 8 SI 302	PLZKBR7B8G	
ZR 7 SI 332 S	PLZKBR7B8G	
BRISK	→ NGK	V-Line
D 12 YC	BCP7ES	
D 14 Y	BCP7ES	
D 14 YC	BCP7ES	
D 15 Y	BCP6ES	17
D 15 YC	BCP6ES	17
D 17 Y	BCP5ES	16
D 17 YC	BCP5ES	16
DOX 15 LE 1	ZFR6T-11G	44
DR 12 YC	BKR7E	
DR 14 YC	BKR7E	
DR 14 ZC	ZFR7F-11	
DR 14 ZC 1	BCPR7ES-11	
DR 15 TC	BKUR5ET-10	
DR 15 YC	BKR6ES	28
DR 15 Z	BKR6ES	28
DR 15 Z 1	BKR6ES-11	14
DR 17 YC	BKR5ES	35
F 14 YC	AP7FS	
F 15 YC	AP6FS	
FR 14 YC	APR6FS	
FR 15 YC	APR6FS	
G 12 YC	BP7EFS	
G 14 Y	BP7EFS	
G 14 YC	BP7EFS	
G 15 Y	BP6EFS	5
G 15 YC	BP6EFS	5
G 17 Y	BP5EFS	
G 17 YC	BP5EFS	
GR 15 YC	BPR6EFS	7
GR 17 YC	BPR5EFS	
K 17 C	B6S	
K 19	B-4	
L 08 JW	BR10EIX	
L 08 W	BR10EIX	
L 10 JW	BR8EIX	
L 12 W	BR9EIX	
L 12 Y	BP8ES	
L 12 YC	BP8ES	





BRISK	→ NGK	V-Line
L 14	B8ES	
L 14 C	B8ES	
L 14 Y	BP7ES	
L 14 YC	BP7ES	
L 15	B7ES	
L 15 C	B7ES	
L 15 W	BR7EIX	
L 15 Y	BP6ES	4
L 15 YC	BP6ES	4
L 17	B6ES	
L 17 C	B6ES	
L 17 W	BR7EIX	
L 17 Y	BP5ES	8
L 17 YC	BP5ES	8
L 19 C	B5ES	
LR 12 YC	BPR8ES	
LR 12 ZC	BPR8ES	
LR 14 TXS	BUR6ET	1
LR 14 YC	BPR7ES	19
LR 14 ZC	BPR7ES	19
LR 14 ZC 1	BPR7ES-11	
LR 15 TXS	BUR6ET	1
LR 15 YC	BPR6ES	2
LR 15 Z	BPR6ES	2
LR 15 Z 1	BPR6ES-11	13
LR 17 YC	BPR5ES	6
N 14	B8HS	
N 14 C	B8HS	
N 14 Y	BP7HS	
N 14 YC	BP7HS	
N 15	B7HS	
N 15 C	B7HS	
N 15 W	BR8HIX	
N 15 Y	BP6HS	18
N 15 YC	BP6HS	18
N 17	B6HS	
N 17 C	B6HS	
N 17 W	BR7HIX	
N 17 Y	BP5HS	
N 17 YC	BP5HS	
N 19	B5HS	
N 19 C	B5HS	
NR 15 YC	BPR6HS	3
CHAMPION	→ NGK	V-Line
A 50 R	R2349-11	
A 51 R	R2525-10	
A 53 C	R2349-11	
A 53 R	R2349-11	
A 55 C	R2525-10	
A 55 R	R2525-10	
A 55 V	R2349-11	
A 57 CST	R2525-10	

CHAMPION	→ NGK	V-Line
A 57 G	R2525-10	
A 59 C	D9EA	
A 59 G	DR9EIX	
A 59 GC	DCPR9EIX	
A 6 G	DR8EIX	
A 6 GC	DR8EIX	
A 61	D9EA	
A 61 G	DR9EIX	
BL 11 Y	BP5FS	
BL 13 Y	BP5FS	
BL 7 Y	BP7FS	
BL 9 Y	BP6FS	
BN 12 Y	BP5EFS	
BN 2	B9EFS	
BN 6 Y	BP7EFS	
BN 7 Y	BP6EFS	5
BN 89 Y	BP6EFS	5
BN 9 Y	BP6EFS	5
C 10 YCC	BCP6ES	17
C 11 YCC	BCP5ES	16
C 12 YCC	BK5E	
C 281 YC	BCP6ES	17
C 55	R7436-10	
C 55 R	R7436-10	
C 57	R7436-9	
C 57 A	R7436-10	
C 57 C	R7436-9	
C 57 CX	R7434-10	
C 57 JC4	R7436-10	
C 57 YCST	R7436-9	
C 59	R7436-9	
C 59 C	R7436-9	
C 6 BYC	BCP7ET	
C 6 VPYC	BKR7EIX-11	
C 6 YCC	BCP7ES	
C 61	R7436-8	
C 7 Y	BCP7ES	
C 7 YC	BCP7ES	
C 7 YCC	BCP7ES	
C 7 YCX	BCP7ES	
C 9 MCC	ZFR5F	53
C 9 Y	BCP6ES	17
C 9 YC	BCP6ES	17
C 9 YCC	BCP6ES	17
C 9 YCX	BCP6ES	17
CCH 446	LZFR5CI-11	
CCH 9299	ILTR6E11	
CCH9010	LZFR5CI-11	
CCH9013	IZFR5R7G	
CCH9047	DILKR6A11	
D 6	AB-8	
D 9	AB-6	



CHAMPION	→ NGK	V-Line
D 9 J	AB-6	
D 10	AB-6	
D 14	AB-6	
D 16	AB-6	
D 16 J	AB-6	
D 21	AB-6	
D 23	AB-6	
EON 1	BKR6ES	28
EON 2	BKR5ES	35
EON 3	BPR5EFS	
EON 4	TR5A-10	
EON 5	BPR6ES	2
EON 6	BPR5ES	6
F 7 Y	AP7FS	
F 7 YC	AP7FS	
F 7 YCC	AP7FS	
F 9 Y	AP6FS	
F 9 YC	AP6FS	
F 10	A6FS	
F 10 C	A6FS	
F 11 Y	AP5FS	
F 11 YC	AP5FS	
F 14 Y	AP5FS	
F 62 Y	AP8FS	
F 81 Y	AP8FS	
F 82	A8FS	
F 83 Y	AP8FS	
FN 507 Y	BCP7ES	
G 2	C8E	
G 61	C8E	
G 63	C8E	
G 63 R	CR8EIX	
H 03	B6S	
H 8	B-6L	
H 8 C	B-6L	
H 8 J	B-6L	
H 10	B-6L	
H 10 C	B-6L	
H 10 J	B-6L	
H 11	B-4L	
H 12	B-4L	
J 11	B-4	
J 11 C	B-4	
J 11 J	B-4	
J 4	B7S	
J 4 C	B7S	
J 4 J	B7S	
J 5	B7S	
J 6	B6S	
J 6 C	B6S	
J 6 J	B6S	
J 7	B6S	

CHAMPION	→ NGK	V-Line
J 7 J	B6S	
J 8	B6S	
J 8 C	B6S	
J 8 J	B6S	
K 3 G	AB-8	
K 5 G	AB-8	
K 7	AB-8	
K 8	AB-8	
K 8 G	AB-8	
K 9	AB-7	
K 13	AB-6	
K 15 J	AB-6	
KA6ZPHPB1	IKER7A8EGS	
L 3 G	BR8HIX	
L 4 G	BR7HIX	
L 4 J	B7HS	
L 5	B7HS	
L 6 G	BR7HIX	
L 7 J	B6HS	
L 9 G	BR6HIX	
L 9 J	B6HS	
L 10	B6HS	
L 12 Y	BP5HS	
L 288	B5HS	
L 64 Y	BP7HS	
L 66 Y	BP6HS	18
L 77 J	B7HS	
L 77 JC	B7HS	
L 78	B7HS	
L 78 C	B7HS	
L 81	B7HS	
L 81 Y	BP7HS	
L 82	B6HS	
L 82 C	B6HS	
L 82 Y	BP6HS	18
L 82 YC	BP6HS	18
L 82 YCC	BP6HS	18
L 85	B6HS	
L 85 Y	BP6HS	18
L 86	B6HS	
L 86 C	B6HS	
L 86 CC	B6HS	
L 87 Y	BP6HS	18
L 87 YC	BP6HS	18
L 87 YCC	BP6HS	18
L 90	B5HS	
L 90 C	B5HS	
L 92 LCC	BP5HS	
L 92 Y	BP5HS	
L 92 YC	BP5HS	
L 92 YC4	BP5HS-10	
N 2	B9ES	



CHAMPION	→ NGK	V-Line
N 2 C	B9ES	
N 2 G	BR9EIX	
N 3	B8ES	
N 3 C	B8ES	
N 3 G	BR8EIX	
N 4	B7ES	
N 4 C	B7ES	
N 4 G	BR7EIX	
N 4 YC	BP9ES	
N 5	B6ES	
N 5 C	B6ES	
N 6	B6ES	
N 6 BYC	BUR6ET	1
N 6 GY	BPR8EIX	
N 6 Y	BP8ES	
N 6 YC	BP8ES	
N 6 YCC	BP8ES	
N 7	B7ES	
N 7 BMC	BUR6ET	1
N 7 BYC	BUR6ET	1
N 7 GY	BPR7EIX	
N 7 Y	BP7ES	
N 7 YC	BP7ES	
N 7 YCC	BP7ES	
N 7 YCX	BP7ES	
N 8	B6ES	
N 8 GY	BPR6EIX	
N 8 L	ZGR5C	
N 8 Y	BP6ES	4
N 9 BMC	BPR5EIKU	
N 9 BYC	BUR6ET	1
N 9 BYC4	BP5ET-10	
N 9 Y	BP6ES	4
N 9 YC	BP6ES	4
N 9 YC4	BP6ES-11	
N 9 YCC	BP6ES	4
N 9 YCE	BP5ES	8
N 9 YCX	BP6ES	4
N 10 PY	BPR6EIX	
N 10 Y	BP6ES	4
N 10 Y4	BP6ES-11	
N 10 YC	BP5ES	8
N 11 Y	BP5ES	8
N 11 YC	BP5ES	8
N 11 YC4	BP5ES-11	
N 11 YCC	BP5ES	8
N 12 Y	BP5ES	8
N 12 YC	BP5ES	8
N 12 YCC	BP5ES	8
N 13 L	ZGR5C	
N 13 Y	BP5ES	8
N 14 LY	ZGR5C	

CHAMPION	→ NGK	V-Line
N 14 Y	BP5ES	8
N 16 Y	BP4ES	
N 16 YC	BP4ES	
N 55 G	BR10EIX	
N 57 G	BR10EIX	
N 59 G	BR10EIX	
N 60	B9ES	
N 60 R	B8EG	
N 60 Y	BPR10EVX	
N 62 R	B8EG	
N 63 Y	BP9ES	
N 64 Y	BP8ES	
N 65 Y	BP7ES	
N 66 Y	BP6ES	4
N 74 C	BUR6EB-11	
N 79 Y	BP6ES	4
N 80 G	BR10EIX	
N 82 G	BR10EIX	
N 84 G	BR10EIX	
N 86 G	BR9EIX	
N 87	B8EG	
N 87 G	BR8EIX	
N 89 GY	BP6ES	4
N 89 Y	BP5ES	8
N 92 Y	BP4ES	
N 180 B	B7EM	
N 279 YC	BP7ES	
N 281 YC	BP6ES	4
N 288	B5ES	
OBL 9 Y	BPR6FS	
OE 001	BP6ES	4
OE 002	BKR6ES	28
OE 003	BCP6ES	17
OE 004	BPR6ES	2
OE 005	BKR6ES	28
OE 006	BPR6ES	2
OE 007	BP6HS	18
OE 008	BPR7ES	19
OE 009	BP6EFS	5
OE 010	BP7ES	
OE 011	BPR6EFS	7
OE 012	BUR6ET	1
OE 013	BKR5ES	35
OE 014	BCPR7ES	
OE 015	BP5ES	8
OE 016	BKR6ES	28
OE 017	BCP7ES	
OE 018	BPR7ES	19
OE 019	BKR5EK	23
OE 020	BPR6EFS	7
OE 021	BCPR6ET	
OE 022	BP6ES	4



CHAMPION	→ NGK	V-Line
OE 023	BCP6ES	17
OE 024	BKR6E-11	14
OE 025	BUR6ET	1
OE 026	BKR6EK	20
OE 027	BUR5ET-10	21
OE 028	BP5ET-10	
OE 030	BKR6EKC	26
OE 031	PTR5A-13	25
OE 032	BKUR6ET-10	24
OE 033	BKR6EZ	38
OE 034	BKR6ES	28
OE 035	LFR5B	46
OE 036	BP6EFS	5
OE 037	B6HS	
OE 038	BP6HS	18
OE 039	BKR6ES-11	14
OE 040	B9ES	
OE 041	ZFR5F	53
OE 042	BPR5ES	6
OE 043	BCPR7ES	
OE 044	BUR6ET	1
OE 045	BPR5ES	6
OE 046	BP7ES	
OE 048	BPR6ES-11	13
OE 049	BPR5ES-11	
OE 050	BP7EFS	
OE 051	BPR5ES	6
OE 052	DCPR9EIX	
OE 053	APR6FS	
OE 054	APR6FS	
OE 055	BP5ES	8
OE 056	BKR7ES-11	
OE 057	BCP5ES	16
OE 058	BCP7ES	
OE 059	BP5HS	
OE 060	ZGR5B	
OE 061	AP7FS	
OE 063	BKR6ES-11	14
OE 064	BPR6HS	3
OE 065	BP5ES	8
OE 067	BP7EFS	
OE 068	B8ES	
OE 070	BP6HS	18
OE 071	BPR6HS	3
OE 074	B6ES	
OE 075	BCP7ES	
OE 076	BCP7ET	
OE 077	BCPR6ET	
OE 078	BR8EIX	
OE 079	B7ES	
OE 080	BKR7ES-11	
OE 084	BP8ES	

CHAMPION	→ NGK	V-Line
OE 085	BKR5EKU	
OE 087	BP8ES	
OE 088	BKR5E	35
OE 089	ZFR6F-11	
OE 090	BP7EFS	
OE 093	BKR5EZ	36
OE 094	BCPR7ES	
OE 095	BUR6ET	1
OE 096	B6HS	
OE 098	BR7ES	
OE 100	BPR5EKU	
OE 102	BKR6EZ	38
OE 103	DCPR9EIX	
OE 104	BP6HS	18
OE 105	GR4	
OE 106	BP5ES	8
OE 107	BPR7ES-11	
OE 108	BR8ES	
OE 109	BUR6ET	1
OE 110	BCPR7ES	
OE 111	BPR6ES	2
OE 112	DR8EIX	
OE 114	BRE527Y-11	
OE 115	ZFR5N	
OE 116	BPR8ES	
OE 119	BKR6ES	28
OE 120	BKUR5ET-10	
OE 122	PMR7A	
OE 124	PFR5J-11	
OE 125	BR9EIX	
OE 127	BKR5E	35
OE 129	BKR7EIX-11	
OE 130	LZKAR7B	
OE 134	PFR5J-11	
OE 136	PFR6J-11	
OE 138	PFR5G-11	
OE 141	BKR6EIX	
OE 143	PFR6G-9	
OE 144	BKUR6ET-10	24
OE 146	PFR5G-13E	
OE 151	BPR5EFS	
OE 152	BKR5E-11	33
OE 154	ZFR5F-11	40
OE 155	APR6FS	
OE 156	ZGR5C	
OE 160	ZFR4F-11	
OE 161	GR4	
OE 162	BR6ES	
OE 163	LZTR4A-11	
OE 165	R7436-9	
OE 167	PLZTR5A-13	
OE 168	TR5IX	



CHAMPION	→ NGK	V-Line
OE 169	R5724-9	
OE 171	BPR6FS	
OE 173	R2525-10	
OE 174	PTR5A-13	25
OE 175	LFR5AP-11	
OE 178	LFR5B	46
OE 190	IFR5G11	
OE 197	PLKR7A	
OE 198	ZFR6V-G	
OE 199	DCPR8E	
OE 201	LZKR6B-10E	49
OE 244	IKER7A8EGS	
OE 245	SILZKGR8B8S	
OE244	IKER7A8EGS	
ON 11 Y	BP5ES	8
ON 12 Y	BP5ES	8
ON 3	BR8ES	
PG 2 PHP	PMR8A	
PG 4 PHP	PMR7A	
PL 9 YC	BP6HS	18
PN 5 C	B8ES	
Q 504 V	R2349-10	
QC 12 YC	BKR5ES	35
QC 501 V	R7434-10	
QC 9 MC4	ZFR6F-11	
QL 78 C	BR7HS	
QL 78 YC	BPR7HS	
QL 82 YC	BPR6HS	3
QL 87 YC	BPR6HS	3
QN 2 G	BR9EIX	
QN 3	BR8ES	
QN 3 C	BR8ES	
R 54 G	R2525-10	
R 6 G	DR8EIX	
RA 4 HCC	DCPR8E	
RA 4 HCX	DCPR9EIX	
RA 59 GC	DCPR9EIX	
RA 59 PP	DCPR9EIX	
RA 7 YC	DCPR8E	
RA 8 GHC	DCPR6E	
RA 8 HC	DCPR7E	
RBL 11 Y6	BPR5FS-15	
RBL 13 Y6	BPR5FS-15	
RBL 15 Y	BPR4FS	
RBL 15 Y4	BPR4FS-11	
RBL 15 Y6	BPR4FS-15	
RBL 16 Y	BPR4FS	
RBL 17 Y	BPR4FS	
RBL 17 Y6	BPR4FS-15	
RBL 9 Y	BPR6FS	
RBN 12 Y	BPR5EFS	
RBN 13 Y	BPR5EFS	

CHAMPION	→ NGK	V-Line
RBN 14 Y	BPR5EFS	
RBN 9 Y	BPR6EFS	7
RC 6 VPYC	BKR7EIX-11	
RC 6 YC	BCPR7ES	
RC 6 YCC	BCPR7ES	
RC 7 BMC	BCPR6ET	
RC 7 BYC4	BCPR6ET	
RC 7 GYC	BKR7EIX-11	
RC 7 GYG	BKR6EIX	
RC 7 Y	BCPR7ES	
RC 7 YC	BCPR7ES	
RC 7 YC3	BKR7E	
RC 7 YC4	BKR7ES-11	
RC 7 YCC	BCPR7ES	
RC 7 YCC4	BKR7ES-11	
RC 8 BYC	BKR6EKC	26
RC 8 DMC	BKR6EK	20
RC 8 PYCB	PFR6G-9	
RC 8 PYP	PFR6J-11	
RC 8 PYP4	PFR6G-11	
RC 8 PYPB4	PFR5G-13E	
RC 8 VTYC4	BKUR6ET-10	24
RC 8 YC	BKR5E	35
RC 8 YC4	BKR5E-11	33
RC 8 YCC	BKR6ES	28
RC 8 YCL	BKR6ES	28
RC 9 BMC	BKR5EKU	
RC 9 MC4	ZFR5F-11	40
RC 9 MCC4	ZFR6F-11	
RC 9 TMC	BKR6EKUB	
RC 9 YC	BKR6ES	28
RC 9 YC4	BKR6ES-11	14
RC 9 YC5	BKR6E-11	14
RC 9 YCC	BKR6ES	28
RC 9 YCC4	BKR6E-11	14
RC 9 YCN4	BKR6E-11	14
RC 10 DMC	BKR5EK	23
RC 10 ECC	ZFR6F-11	
RC 10 MCC	ZFR6V-G	
RC 10 PYC	BKR6EIX	
RC 10 PYP4	PFR5J-11	
RC 10 PYPB4	PFR5G-11	
RC 10 WMPB3	IZFR5R7G	
RC 10 YC	BKR5E	35
RC 10 YC4	BKR6ES-11	14
RC 10 YCC	BKR6ES	28
RC 10 YCL	BKR5EZ	36
RC 11 LCC4	BRE527Y-11	
RC 11 PYPB4	PFR5G-11	
RC 12 ECC	ZFR5N	
RC 12 LYC	ZFR5F	53
RC 12 MC4	PZFR5F-11	



CHAMPION	→ NGK	V-Line
RC 12 MC5	ZFR5F-11	40
RC 12 MCC4	ZFR5F-11	40
RC 12 PEC5	ZFR5LP-13G	
RC 12 PYP	PFR5J-11	
RC 12 YC	BKR5ES	35
RC 12 YC5	FR45	
RC 14 ES	ZFR5LP-13G	
RC 14 YC	BKR5ES	35
RC 14 YC4	BKR5E-11	33
RC 503 C	R7433-8	
RC 87 PYC	BKUR6ET-10	24
RC 87 YC	BKR6ES	28
RC 87 YCC	BKR6EZ	38
RC 87 YCL	BKR6EZ	38
RC 89 TMC	BKUR5ET-10	
RC 89 YCC	BKR5EZ	36
RD 9	AB-6	
RD 14	AB-6	
RD 16	AB-6	
RD 16 J	AB-6	
RE 7 PYC5	PTR5A-13	25
RE 7 YCC	PTR5A-13	25
RE 10 LC	TR5-11X	
RE 10 PMC5	PTR5A-13	25
RE 10 YC4	BKR5ES-11	33
RE 14 MCC4	LZTR4A-11	
RE 14 MCC5	LZTR4A-11	
RE 14 PLP5	PLZTR5A-13	
REA 12 WMB4	LZKAR6AP-11	
REA 8 MCL	LZKAR7B	
REA 8 MX	LZKAR7B	
REC 10 PYC4	LFR5AP-11	
REC 10 WYPB4	IFR5G11	
REC 9 MCLX	LFR5B	46
REC 9 YCL	LFR5B	46
REC10WMPB	LZFR5CI-11	
REC12 MCC4	LZFR5CI-11	
RER 8 MC	LZKR6B-10E	49
RER 8 YC	PLKR7A	
RER 8 ZWYCB4	ILZKR7B11GS	
RER12WMPB04	DILKR6A11	
RERX 4 ZWYPB	SILZKGR8B8S	
RES 9 YCC4	PTR5A-13	25
RF 7 YC	APR6FS	
RF 7 YCC	APR6FS	
RF 9 Y	APR6FS	
RF 9 Y5	APR6FS	
RF 9 YC	APR6FS	
RF 10	AR6FS	
RF 10 C	AR6FS	
RF 11 Y	APR6FS	
RF 11 YC	APR6FS	

CHAMPION	→ NGK	V-Line
RF 14 Y	APR5FS	
RFN 14 LY	ZFR4F-11	
RG 2 PHP	CR8EIX	
RG 4 PHP	PMR7A	
RH 10 C	B-6L	
RH 18 Y	B-4L	
RJ 14 CC	XR4	
RJ 18 YC6	XR45IX	
RL 4 J	BR7HS	
RL 12 Y	BPR6HS	3
RL 77 J	BR7HS	
RL 78	BR7HS	
RL 78 C	BR7HS	
RL 82 Y	BPR6HS	3
RL 82 YC	BPR6HS	3
RL 82 YCC	BPR6HS	3
RL 87 Y	BPR6HS	3
RL 87 YC	BPR6HS	3
RL 95 YC	BPR5HS	
RN 2 G	BR9EIX	
RN 3	BR8ES	
RN 3 C	BR8ES	
RN 3 G	BR8EIX	
RN 4	BR7ES	
RN 4 C	BR7ES	
RN 5	BR6ES	
RN 5 C	BR6ES	
RN 6	BR6ES	
RN 6 Y	BPR8ES	
RN 6 YC	BPR8ES	
RN 7 GY	BPR7EIX	
RN 7 Y	BPR7ES	19
RN 7 YC	BPR7ES	19
RN 7 YCC	BPR7ES	19
RN 7 YCC4	BPR7ES-11	
RN 74 C	BUR6EB-11	
RN 8	BR5ES	
RN 8 L	ZGR5C	
RN 8 VTYC4	BUR6ET	1
RN 9 BMC	BPR5EKU	
RN 9 GY	BPR6EIX	
RN 9 LCC	ZGR5B	
RN 9 Y	BPR6ES	2
RN 9 YC	BPR6ES	2
RN 9 YC4	BPR6ES-11	13
RN 9 YCC	BPR6ES	2
RN 10 GY	BPR6EIX	
RN 10 PYP4	PGR5A-11	
RN 10 VTYC	BUR5ET	22
RN 10 VTYC4	BUR5ET-10	21
RN 10 Y	BPR6ES	2
RN 10 Y4	BPR6ES-11	13





CHAMPION	→ NGK	V-Line
RN 10 YC	BPR6ES	2
RN 11 Y	BPR5ES	6
RN 11 YC	BPR5ES	6
RN 11 YC4	BPR5ES-11	
RN 11 YCC	BPR5ES	6
RN 12 GY	BPR5EIX	
RN 12 MC4	BPR4EY-11	
RN 12 Y	BPR5ES	6
RN 12 YC	BPR5ES	6
RN 12 YC4	BPR5ES-11	
RN 12 YC6	BPR5ES-13	
RN 12 YCC	BPR5ES	6
RN 13 L	ZGR5C	
RN 13 LYC	ZGR5C	
RN 14 LY	ZGR5C	
RN 14 MC5	BPR4EY-11	
RN 14 PMP5	GR4	
RN 14 Y	BPR5ES	6
RN 14 Y6	BPR5ES-13	
RN 14 YC	GR4	
RN 16 Y	BPR4ES	
RN 16 YC5	BPR4ES-13	
RN 16 YC6	BPR4EY-11	
RN 180 B	B7EM	
RS 5 C	BR7EFS	
RS 9 YC	BPR6EFS	7
RS 9 YCC	BPR6EFS	7
RS 10 LC	TR5-1	
RS 12 PYP	TR5IX	
RS 12 YC	BPR5EFS	
RS 12 YC6	BPR5EFS-13	
RS 13 LYC	TR4	
RS 14 LC	TR5-1	
RS 14 LYC	TR4	
RS 14 PYP	TR4IX	
RS 14 YC	BPR5EFS	
RS 14 YC6	TR55IX	
RS 15 LYC	TR4	
RS 16 YC	TR4	
RS 17 YX	TR4	
RV 9 YC	BPR6FS	
RV 12 YC6	BPR5FS-15	
RV 15 YC	BPR4FS	
RV 15 YC4	BPR4FS-11	
RV 15 YC4 /T04	BPR4FS-11	
RV 15 YC6	BPR4FS-15	
RV 17 YC	BPR4FS	
RV 17 YC6	BPR4FS-15	
RZN 12 Y	BPR5EFS	
RZN 12 Y5	BPR5EFS	
S 6 YC	BP7EFS	
S 7 YC	BP7EFS	

CHAMPION	→ NGK	V-Line
S 7 YCC	BP7EFS	
S 9 YC	BP6EFS	5
S 9 YCC	BP6EFS	5
S 59 C	R5724-9	
S 59 CST	R5724-9	
S 279 YC	BP6EFS	5
S 281 YC	BP6EFS	5
S 379 YC	BP7EFS	
UD 16	AB-6	
UF 9 Y	AP6FS	
UF 11 Y	AP6FS	
UJ 2 J	B8S	
UJ 4 J	B7S	
UJ 6	B6S	
UJ 8	B6S	
UJ 81 C	B7S	
UJ 81 J	B7S	
UK 10	AB-6	
UL 4 J	B7HS	
UL 81 C	B7HS	
UL 81 J	B7HS	
UL 82 Y	BP7HS	
UN 79 Y	BP6ES	4
V 9 YC	BP6FS	
V 12 YC	BP5FS	
V 61	R5673-8	
V 63 C	R5673-7	
XC 92 YC	BKR5E	35
DELPHI	→ NGK	V-Line
41970	PTR5C-13	
DENSO	→ NGK	V-Line
D 1	BUR6ET	1
D 2	BPR6ES	2
D 3	BPR6HS	3
D 4	BP6ES	4
D 5	BP6EFS	5
D 6	BPR5ES	6
D 7	BPR6EFS	7
D 8	BP5ES	8
D 9	BPR5EY	9
D 10	BPR6EY-11	10
D 11	BCPR6EY-11	
D 12	BKR6E	28
D 13	BPR6ES-11	13
D 14	BKR6E-11	14
D 15	ZGR5A	15
D 17	BCP6ES	17
D 18	BP6HS	18
D 19	BPR7ES	19
D 20	BKR6EKUB	
D 21	BKR5E-11	33
D 22	BKR6E	28



DENSO	→ NGK	V-Line
D 23	BCPR7ES	
D 24	BP5EY	
D 25	BP6EY	
D 26	BPR6EY	
D 27	BP7ES	
D 28	AP6FS	
D 29	BUR6ET	1
D 30	BKR5EYA	
D 31	BKR6EYA	
D 32	BKR5EYA-11	39
D 33	BKR6EY-11	
D 34	ZFR4F-11	
D 35	ZFR5F-11	40
D 36	ZFR5E-11	
D 37	ZFR5J-11	
D 38	ZFR6J-11	
D 39	BCPR5EY	
D 40	BCPR5EY-11	
D 41	BCPR6EY-11	
D 42	BCPR5E	32
D 43	BCPR5EY-11	
D 44	ZFR6A-11	
D 45	BP4EY	
D 47	BP5EY-11	
D 49	BP6EY-11	
D 51	BUR6EB-11	
D 53	BR8EQ-14	
D 54	B5ES	
D 55	B6ES	
D 56	B7ES	
D 57	B5HS	
D 58	B6HS	
D 59	BPR5EFS	
D 62	BP5FS	
D 64	BPR5FS-11	
D 65	BPR5FS-15	
D 67	BPR6FS	
D 69	BPR6FS	
D 71	BP5HS	
D 73	BPR4FS	
D 74	BP7HS	
D 76	BKUR6ET-10	24
D 77	BKR5E	35
D 79	BUR7EQ	
D 80	BUR9EQ	
D 81	APR6FS	
D 85	BP4ES	
D 86	BPR5EY-11	
D 89	BRE529Y	
D 94	BKR6EKB-11	
D 95	BRE529Y-11	
D 96	BCPR5EY-11	

DENSO	→ NGK	V-Line
D 98	APR5FS	
D 99	BKR5EKB-11	
D 100	BPR5ES-11	
D 101	BKR5E-N-11	
D 102	BCPR6EY	
D 103	BKR5EIX	
D 104	BKUR6EK	
D 105	BKUR6ET	27
D 109	BR9EQ-14	
D 110	ZFR6K-11	
D 112	BKR6EKC	26
D 116	BKR7E-11	
D 117	BKR6E-N-11	
D 118	LFR6C-11	48
D 130	BP5EY-11	
D 136	BR7ES	
D 137	BPR4EY-11	
D 138	BUR6EA-11	
D 139	BPR5E-11	
D 140	BPR4ES	
D 143	BCRE527Y	
D 145	BRE527Y-11	
D 148	BKR7E	
D 149	BKR5EIX-11	
D 150	BUR7EB-11	
D 151	BCPR4EY-11	
D 152	ZFR4F-11	
D 153	BCPR7ES-11	
D 155	ZFR5A-11	
D 156	BKR8E-11	
D 160	BPR4FS-15	
D 162	BP6FS	
D 163	BP7EFS	
D 164	BKUR7ET	
D 165	BP7ET	
D 166	LFR5A-11	
D 167	LZKAR7A	54
D 168	FR6EI	
D 171	LKR7B-9	
DXE 22 HCR 11 S	DILZKAR7C11S	
DXE 22 HQR D11S	DILKAR7G11GS	
DXU 22 HCR D11S	DILZKR7B11GS	
FK 16R A8	DIFR5C	
FK 20 HBR 11	DFH6B-11A	
FXE 20 HR 11	DILKAR6A11	
FXE 22 HR 11	DF7H-11B	
FXE 24 HR 11	DF8H-11B	
FXU16HR11	DILKR6A11	
I 01	BCPR5EIX-11	
I 02	BCPR6EIX-11	
I 03	BKR5EIX-11	
I 04	BKR6EIX-11	





DENSO	→ NGK	V-Line
I 05	BPR5EIX-11	
I 06	BPR6EIX-11	
I 07	BPR7EIX	
I 08	DCPR7EIX	
I 10	IRIWAY7	
I 11	IRIWAY8	
I 12	IRIWAY9	
I 13	IRITOP7	
I 14	IRITOP8	
I 15	IRITOP9	
I 16	BR8EIX	
I 17	BR9EIX	
I 19	BR10EIX	
I 25	TR5IX	
I 26	TR6IX	
I 27	TR7IX	
I 28	TR8IX	
I 30	UR5IX	
I 31	UR6IX	
I 37	IRIMAC9	
I 43	LFR5AIX-11	
I 44	LFR6AIX-11	
I 62	CR8EIX	
I 69	CR9EHIX-9	
I 72	DR8EIX	
I 73	DR9EIX	
I 78	BPR6HIX	
I 79	BR7HIX	
I 80	BR8HIX	
IK 01-24	R7434-8	
IK 01-27	R7434-9	
IK 01-31	R7434-10	
IK 02-24	R7434-8	
IK 02-27	R7434-9	
IK 02-31	R7434-10	
IK 16	BKR5EIX-11	
IK 16TT	DIFR5C	
IK 16TT	DIFR5E11	
IK 20	BKR6EIX-11	
IK 22	IRIWAY7	
IK 24	IRIWAY8	
IK 27	IRIWAY9	
IKH 01-24	R7438-8	
IKH 01-27	R7438-9	
IKH 01-31	R7438-10	
IKH 16	LFR5AIX-11	
IKH 20	LFR6AIX-11	
IKH 20 TT	DILFR6A11	
IQ 01-24	R7436-8	
IQ 01-27	R7436-9	
IQ 01-31	R7436-10	
IQ 02-24	R7436-8	

DENSO	→ NGK	V-Line
IQ 02-27	R7436-9	
IQ 02-31	R7436-10	
IQ 16	BCPR5EIX-11	
IQ 20	BCPR6EIX-11	
IQ 22	IRITOP7	
IQ 24	IRITOP8	
IQ 27	IRITOP9	
IRE 01-27	R7420-9	
IRE 01-31	R7420-10	
IRE 01-32	R7420-105	
IT 16	TR5IX	
IT 20	TR6IX	
IT 22	TR7IX	
IT 24	TR8IX	
ITF 16	UR5IX	
ITF 20	UR6IX	
ITV 20 TT	ILTR6E11	
IU 24	CR8EIX	
IUH 27	CR9EHIX-9	
IW 01-24	R7376-8	
IW 01-27	R7376-9	
IW 01-31	R7376-10	
IW 06-27	R7376-9	
IW 06-31	R7376-10	
IW 16	BPR5EIX-11	
IW 20	BPR6EIX-11	
IW 22	BPR7EIX	
IW 24	BR8EIX	
IW 27	BR9EIX	
IW 31	BR10EIX	
IWF 20	BPR6HIX	
IWF 22	BR7HIX	
IWF 24	BR8HIX	
IX 24	DR8EIX	
IX 27	DR9EIX	
IXEH 22 TT	ILKAR7K11S	
IXU 01-27	R2525-9	
IXU 01-31	R2525-10	
IXU 01-34	R2349-11	
IXU 22	DCPR7EIX	
IXU 22 C	KR7AI	
IXU 27	IRIMAC9	
J 16 AR-U 11	BRE527Y-11	
J 16 A-U 11	BE527Y-11	
J 16 AY	BPR5EY-11	
J 16 AYR	BPR5EJ	
J 16 BR-U	BRE529Y	
J 16 BR-U 11	BRE529Y-11	
J 16 B-U 11	BE529Y-11	
J 16 CR-U	ZGR5A	15
J 16 C-U	BPR5EY	9
J 20 AY	BPR6EY-11	10



DENSO	→ NGK	V-Line
K 14 PR-U 11	BKR4E-11	
K 14 P-U 11	BKR5E-11	33
K 16 DTR-S 11	ZFR5G	
K 16 GPR-U 11	ZFR5E-11	
K 16 HPR-U 11	LFR5A-11	
K 16 PR-L 11	BKR5E-N-11	
K 16 PR-P 11	BKR5EIX	
K 16 PR-TP 11	BKR5EIX-11	
K 16 PR-U	BKR5E	35
K 16 PR-U 11	BKR5E-11	33
K 16 PRUR	BKR5E	35
K 16 PRZU 11	BKR5EIX-11	
K 16 PSR-B 8	FR5EI	
K 16 P-U	BK5E	
K 16 P-U 11	BK5E-11	
K 16 R-U	BKR5EYA	
K 16 R-U 11	BKR5EYA-11	39
K 16 RZ-U 11	BKR5EIX-11	
K 16 TNRS 9	BKR5EKC	
K 16 TR 11	BKR5EKB-11	
K 16 U	BKR5EYA	
K 16 U 11	BKR5EYA-11	39
K 20 DTR-S 11	ZFR6G	
K 20 HR-U	LFR6B	47
K 20 HR-U 11	LFR6C-11	48
K 20 PBR	BKUR6ET	27
K 20 PBR-S 10	BKUR6ET-10	24
K 20 PR-L 11	BKR6E-N-11	
K 20 PR-TP 11	BKR6EIX-11	
K 20 PR-U	BKR6E	28
K 20 PR-U 11	BKR6E-11	14
K 20 PR-U 9 S	BKR6E-9S	
K 20 PRUR	BKR6E	28
K 20 PRZU 11	BKR6EIX-11	
K 20 PSR-B 8	FR6EI	
K 20 P-U	BK6E	
K 20 P-U 11	BK6E-11	
K 20 R-U	BKR6EYA	
K 20 R-U 11	BKR6EY-11	
K 20 RZ	BKR6EIX	
K 20 RZ-U 11	BKR6EIX-11	
K 20 TMR 11	BKR6EKC-N-11	
K 20 TNR	BKR6EKC	26
K 20 TNR-S	BKUR6EK	
K 20 TNRS 9	BKUR6EK-9	
K 20 TR 11	BKR6EKB-11	
K 20 TT	ZFR6U-9	
K 20 TXR	BKR6EKUB	
K 20 U	BKR6EYA	
K 20 U 11	BKR6EYA-11	
K 22 P 11	BK7EK-N-11	
K 22 PB	BCP7ET	

DENSO	→ NGK	V-Line
K 22 PBR-S	BKUR7ET	
K 22 PR-L 11	BKR7E-N-11	
K 22 PR-TP 11	BKR7EIX-11	
K 22 PR-U	BKR7E	
K 22 PR-U 11	BKR7E-11	
K 22 PRUR	BKR7E	
K 22 PRZU	BKR7EIX	
K 22 PRZU 11	BKR7EIX-11	
K 22 P-U 11	BKR7E-11	
K 22 TM 11	BK7EK-N-11	
K 22 TMR	BKR7EKC-N	
K 22 TMR 11	BKR7EKC-N-11	
K 22 TNR	BKR7EKC	
K 22 TNRS	BKUR7EK	
K 24 PR-U 11	BKR8E-11	
K 29 AZ	R7434-10	
KH 16TT	LZFR5CI-11	
KJ 14 CR 11	ZFR4F-11	
KJ 14 CR-L 11	ZFR4F-11	
KJ 16 CR	ZFR5F	53
KJ 16 CR 11	ZFR5J-11	
KJ 16 CR-L 11	ZFR5F-11	40
KJ 16 CR-U 11	ZFR5F-11	40
KJ 20 CR 11	ZFR6J-11	
KJ 20 CR-U 11	ZFR6F-11	
KJ 20 DR-M 11	ZFR6K-11	
KJ 20 SR 11	ZFR6FIX-11	
KJ 206 CR-L 11	ZFR6F-11	
KJ 22 CR 11	ZFR7F-11	
KJ 22 CR-L 11	ZFR7F-11	
KJ 22 CR-L 8	ZFR7F	
L 14 U	AB-6	
M 17	AB-6	
M 22	AB-7	
M 24 S	AB-8	
MA 14 P-U	AP5FS	
MA 16 PR-U	APR5FS	
MA 16 PR-U 11	APR5FS	
MA 16 PR-U 15	APR5FS	
MA 16 P-U	AP5FS	
MA 17 P-U	AP6FS	
MA 20 PR-U	APR6FS	
MA 20 P-U	AP6FS	
MA 20 R-U	AR6FS	
MA 20 R-U 11	AR6FS	
MW 17	AB-6	
MW 22	AB-7	
P 1	BCPR6EP-11	
P 2	BCPR5EIX-11	
P 3	BPR5EP-11	
P 6	BKR6EP-11	
P 8	BKR5EP-11	





DENSO	→ NGK	V-Line
P 10	PZFR5F-11	
P 11	PZFR6F-11	
P 12	BKR6EKP-11	
P 13	PGR5A-11	
P 14	PFR6J-11	
P 15	PFR6G-11	
P 16	PTR5A-13	25
P 16 PR 11	PGR5A-11	
P 16 PR 8	PGR5A	
P 16 R	BPR5EP-11	
P 16 R 13	BPR5EP-11	
P 17	BKR5EKP-11	
P 18	PTR5D-10	31
P 19	PZFR5F	
P 20 PR 11	PGR6A-11	
P 20 PR 8	PGR6A	
P 20 R 8	BPR6EP-8	
P 21	PGR6A-11	
P 22	PFR5B-11	
P 22 PR 8	PGR7A	
P 24	PGR5A	
P 25	BKR6EP-13	
P 26	BKR6EP-8	
P 27	PFR6J	
P 28	PFR6B-11	
P 29	BCPR6EIX-11	
P 30	PFR7G-11S	
P 31	PFR7B	
P 32	BKR6EPA-8	
P 35	PZTR5A-15	
P 36	BCPR6EP-N-8	
P 38	BKR5EKP-13	
P 40	PGR6A	
P 41	PFR5J-11	
P 46	PZFR5F-13	
P 47	PZFR6F-11	
P 50	PFR6G-13	
P 51	BCPR5EP-8	
P 52	PZFR6F	
P 53	BPR6EP-8	
P 54	BPR5EP-11	
P 55	PGR7A	
P 62	BCPR6EIX-11	
P 63	PFR7B-11	
P 80	BKR6EKPA	
PK 16 PR 11	PFR5B-11	
PK 16 PR-L 11	PFR5G-11	
PK 16 PR-P 11	PFR5J-11	
PK 16 R 11	BKR5EP-11	
PK 16 R 8	BKR5EIX-P	
PK 16 TR 11	BKR5EKP-11	
PK 16 TR 13	BKR5EKP-13	

DENSO	→ NGK	V-Line
PK 20 GR 8	BKR6EPA-8	
PK 20 PR 11	PFR6B-11	
PK 20 PR-L 11	PFR6G-11	
PK 20 PR-L 13	PFR6G-13	
PK 20 PRP	PFR6J	
PK 20 PR-P 11	PFR6J-11	
PK 20 PR-P 8	PFR6J	
PK 20 PRTP	PFR6M	
PK 20 PTR-S 9	BKR6EKPA	
PK 20 R 11	BKR6EP-11	
PK 20 R 13	BKR6EP-13	
PK 20 R 8	BKR6EP-8	
PK 20 RP 8	BKR6EP-N-8	
PK 20 TR 11	BKR6EKP-11	
PK 22 PR 11	PFR7B-11	
PK 22 PR 8	PFR7B	
PK 22 PR-L 11	PFR7G-11	
PK 22 PR-L 11 S	PFR7G-11S	
PK 22 PRTP	PFR7M	
PKJ 16 CR 8	PZFR5F	
PKJ 16 CR-L 11	PZFR5F-11	
PKJ 16 CR-L 13	PZFR5F-13	
PKJ 20 CR 8	PZFR6F	
PKJ 20 CR-L 11	PZFR6F-11	
PKJ 20 CR-M 11	PZFR6F-11	
PQ 16 R	BCPR5EIX-11	
PQ 16 R 13	BCPR5EIX-11	
PQ 16 R 8	BCPR5EP-8	
PQ 20 R	BCPR6EP-11	
PQ 20 R 13	BCPR6EIX-11	
PQ 20 R-P 11	BCPR6EIX-11	
PQ 20 R-P 8	BCPR6EP-N-8	
PT 16 EPR-C 13	PTR5C-13	
PT 16 EPR-L 13	PTR5D-10	31
PT 16 VR 13	PTR5A-13	25
PTJ 16 R 15	PZTR5A-15	
Q 14 R-U 11	BCPR4EY-11	
Q 16 PR-TP 11	BCPR5EIX-11	
Q 16 PR-U	BCPR5E	32
Q 16 PR-U 11	BCPR5EY-11	
Q 16 PRZU 11	BCPR5EIX-11	
Q 16 P-U 11	BCPR5EY-11	
Q 16 R-U	BCPR5EY	
Q 16 R-U 11	BCPR5EY-11	
Q 16 RZ-U 11	BCPR5EIX-11	
Q 16 U 11	BCPR5EY-11	
Q 16 Z-U 11	BCPR5EIX-11	
Q 20 PR-P 11	BCPR6EIX-11	
Q 20 PR-U	BKR6E	28
Q 20 PR-U 11	BCPR6EY-11	
Q 20 PRU-L 11	BCPR6EY-N-11	
Q 20 PRZU 11	BCPR6EIX-11	



DENSO	→ NGK	V-Line
Q 20 P-U	BCP6ES	17
Q 20 P-U 11	BKR6E-11	14
Q 20 R-U	BCPR6EY	
Q 20 R-U 11	BCPR6EY-11	
Q 20 RZ-U 11	BCPR6EIX-11	
Q 20 U	BCP6E	17
Q 20 U 11	BKR6E-11	14
Q 20 ZU 11	BCPR6EIX-11	
Q 22 PR-P 11	BKR7EIX-11	
Q 22 PR-U	BCPR7ES	
Q 22 PR-U 11	BCPR7ES-11	
Q 22 PRU-L 11	BCPR7EY-N-11	
Q 22 PRZ-U	BCPR7EIX	
Q 22 PRZ-U 11	BKR7EIX-11	
Q 22 P-U	BCP7ES	
Q 22 P-U 11	BKR7E-11	
Q 27 AZ	R7435-9	
QJ 16 AR-U	BCRE527Y	
QJ 16 C 11	ZFR5A-11	
QJ 16 CR 11	ZFR5A-11	
QJ 20 C 11	ZFR6A-11	
QJ 20 CR 11	ZFR6A-11	
QJ 22 CR 11	ZFR7F-11	
QL 20 TRS	BCPR6EKD	
R 01	R7434-8	
R 02	R7434-9	
R 03	R7434-10	
R 05	R7434-9	
R 06	R7434-10	
R 19	R7420-9	
R 31	R2525-9	
R 32	R2525-10	
R 33	R2349-11	
S 2	IFR6T11	
S 3	IFR5T-8N	
S 4	BKR5EIX-11P	
S 7	IFR6C	
S 11	HB6BIX-11P	
S 12	BKR6EIX-11P	
S 13	IGR7A	
S 14	IFR5E11	
S 17	IFR7G-11KS	
S 18	BKR6EP-8	
S 19	IZFR6K11	
S 20	ZFR6FIX-11	
S 21	IFR6S	
S 22	IFR5E11	
S 22 PR-A 7	IGR7A	
S 24	IZFR6K13	
S 25	IFR6E11	
S 29	IFR7G-11KS	
S-29 A	BUR7EQ	

DENSO	→ NGK	V-Line
S-31 A	BUR9EQ	
S 32	IZFR5K11	
S 33	ILFR6T11	
S 34	IFR5G-11K	
S 37	IKR7C	
S 41	IZFR6K11NS	
S 42	ILFR6J-11K	
S 43	ILKR7B8	
S 45	DILKAR6A11	
S 48	ILKAR7B11	
S 49	DF7H-11B	
S 52	IFR6J11	
S 54	IKR6G11	
S 59	DF8H-11B	
S 61	ILZKR7B11GS	
S 64	HB6AIX-11P	
S 65	DFH6B-11A	
SC 20 HR 11	ILKAR7B11	
SC 16HR11	DF6H-11B	
SD 29 A	BUR7EQ	
SK 16 PR-A 11	IFR5E11	
SK 16 PR-E11	IFR5E11	
SK 16 PR-E13	IFR5E13	
SK 16 PR-L 11	IFR5G-11K	
SK 16 R-P 11	BKR5EIX-11P	
SK 16 R-P 8	IFR5T-8N	
SK 20 BGR 11	HB6AIX-11P	
SK 20 BR 11	HB6BIX-11P	
SK 20 HPR-L 11	ILFR6J-11K	
SK 20 HR 11	ILFR6T11	
SK 20 HR-A 11	ILFR6T11	
SK 20 PR-A 11	IFR6E11	
SK 20 PR-A8	IFR6S	
SK 20 PR-L9	IFR6C	
SK 20 R 11	IFR6T11	
SK 20 R 8-G	LPG1	
SK 20 R-P 11	BKR6EIX-11P	
SK 22 PR-M 11	IFR7G-11KS	
SK 22 PR-M 11 S	IFR7G-11KS	
SKJ 16 DR-M 11	IZFR5K11	
SKJ 20 DR-M 11	IZFR6K11	
SKJ 20 DR-M 11 S	IZFR6K11NS	
SKJ 20 DR-M 13	IZFR6K13	
SVK 20 RZ 11	IFR6J11	
SVK 20 RZ 8	BKR6EP-8	
SXU 22 HCR 11 S	ILZKR7B11GS	
SXU 22 HDR 8	ILKR7B8	
SXU 22 PR 9	IKR7C	
T 04	ZFR6U-9	
T 14 PR-U	BPR4FS	
T 14 PR-U 15	BPR4FS-15	
T 16 EPR-U	BPR5EFS	



DENSO	→ NGK	V-Line
T 16 EX-U	BP5EFS	
T 16 PR-U 11	BPR5FS-11	
T 16 PR-U 15	BPR5FS-15	
T 16 P-U	BP5FS	
T 16 U 15	YR55IX	
T 20 EPR-U	BPR6EFS	7
T 20 EP-U	BP6EFS	5
T 20 EX-U	BP6EFS	5
T 20 PR-U	BPR6FS	
T 20 PR-U 15	BPR6FS	
T 20 P-U	BP6FS	
T 22 EP-U	BP7EFS	
TR 20	B6HS	
TR 22	B7HS	
TR 24	B8HS	
U 24 ESN	C8E	
U 24 ESRNZ-U	CR8EIX	
U 27 FERZ-U 9	CR9EHIX-9	
U 27 FEZ-U 9	CR9EHIX-9	
V 01	BCPR5EIX-11P	
V 02	BCPR6EIX-11P	
V 03	BKR5EIX-11P	
V 04	IZFR6H11	
V 08	DCPR7EIX-P	
V 10	IFR7F-6D	
V 17	ILZFR5B	
V 18	ILZFR6D11	
V 19	LFR7AIX-P	
V 20	BKR6EIX-P	
V 25	HB6BIX-11P	
V 36	BKR7EIX-11PS	
V 39	LFR6AIX-P	
VDCH22F	DILKAR8A8	
VFXEHC 22 G	DILZKAR7C11S	
VK 16	BKR5EIX-11P	
VK 16 J	ZFR5FIX-11P	
VK 20	IZFR6H11	
VK 20 T	LPG1	
VK 20 Y	BKR6EIX-P	
VK 22	IFR7F-6D	
VK 22 G	BKR7EIX-11PS	
VKA 20	HB6AIX-11P	
VKB 20	HB6BIX-11P	
VKH 16	ILZFR5B	
VKH 20	ILZFR6D11	
VKH 20 Y	LFR6AIX-P	
VKH 22	LFR7AIX-P	
VQ 16	BCPR5EIX-11P	
VQ 20	BCPR6EIX-11P	
VW 20 T	LPG2	
VXEHC 24 G	ILZKAR8H8S	
VXU 22	DCPR7EIX-P	

DENSO	→ NGK	V-Line
VXUH 20 I	SILKR6C10E	
VXUHC 22 G	ILZKR7D8	
W 14	B-4	
W 14 EP	BP4ES	
W 14 EPR	BPR4ES	
W 14 EPR 11	BPR4ES-11	
W 14 EPR-U	BPR4ES	
W 14 EP-U	BP4ES	
W 14 EXR-U	BPR4EY	
W 14 EXR-U 11	BPR4EY-11	
W 14 EXR-U 13	BPR4ES-13	
W 14 EXRZ-U	GR4IX	
W 14 EX-U	BP4EY	
W 14 EX-U 11	BP4EY-11	
W 14 EX-U 13	BPR4ES-13	
W 14 EXZ-U	GR4IX	
W 14 L	B-4L	
W 14 U	B-4	
W 14 U 10	B-4	
W 14 US	B-4	
W 16 EKR-S 11	BUR5EB-11	
W 16 EK-S 11	BUR5EB-11	
W 16 EP	BP5ES	8
W 16 E-P 11	BP5ES-11	
W 16 EPB	BP5EY	
W 16 EPB 10	BP5ET-10	
W 16 EPG-U	BPR5EIX	
W 16 EPR	BPR5ES	6
W 16 EPR 11	BPR5ES-11	
W 16 EPR-U	BPR5ES	6
W 16 EPR-U 10	BPR5E-11	
W 16 EPR-U 11	BPR5ES-11	
W 16 EP-U	BP5ES	8
W 16 EP-U 10	BP5ES-11	
W 16 EP-U 11	BP5EY-11	
W 16 EPZ-U	BPR5EIX	
W 16 ES	B5ES	
W 16 ES-L 11	BR5ES	
W 16 ESRL	BR5ES	
W 16 ESR-L 11	BUR5EB-11	
W 16 ESR-U	BR5ES	
W 16 ES-U	B5ES	
W 16 ETL	BPR5EY	9
W 16 ETRS	BPR5EIX-11	
W 16 ETS	BPR5EIX-11	
W 16 EX	BP5EY	
W 16 EXR-U	BPR5EY	9
W 16 EXR-U 11	BPR5EY-11	
W 16 EXR-U 13	BPR5ES-13	
W 16 EXRZ-U	BPR5EIX	
W 16 EX-U	BP5EY	
W 16 EX-U 11	BP5EY-11	



DENSO	→ NGK	V-Line
W 16 EX-U 13	BP5ES-13	
W 16 EXZ-U	BPR5EIX	
W 16 FP	BP5HS	
W 16 FPL	BP5HS	
W 16 FPR	BPR5HS	
W 16 FPR-U	BPR5HS	
W 16 FP-U	BP5HS	
W 16 FPU 10	BP5HS-10	
W 16 FPUL	BP5HS	
W 16 FS	B5HS	
W 16 FS-U	B5HS	
W 16 LS	B-6L	
W 17	B6S	
W 17 ES	BR6ES	
W 17 FP	BP6HS	18
W 20 EKR-S 11	BUR6EB-11	
W 20 EK-S 11	BUR6EB-11	
W 20 EP	B6ES	
W 20 E-P 11	BP6ES-11	
W 20 EPB	BUR6ET	1
W 20 EPBR-S	BUR6ET	1
W 20 EPG-U	BPR6EIX	
W 20 EPR	BPR6ES	2
W 20 EPR 11	BPR6ES-11	13
W 20 EPR-S 11	BUR6EA-11	
W 20 EPR-U	BPR6ES	2
W 20 EPR-U 10	BPR6ES-11	13
W 20 EPR-U 11	BPR6ES-11	13
W 20 EPRZ-U	BPR6EIX	
W 20 EPRZ-U 11	BPR6EIX-11	
W 20 EP-S 11	BUR6EA-11	
W 20 EP-U	BP6ES	4
W 20 EP-U 10	BP6ES-11	
W 20 EP-U 11	BP6ES-11	
W 20 EPZ-U	BPR6EIX	
W 20 ES	B6ES	
W 20 ESL	BR6ES	
W 20 ES-L 11	BUR6EB-11	
W 20 ESR	BR6ES	
W 20 ESRL	BR6ES	
W 20 ESR-L 11	BUR6EB-11	
W 20 ES-U	B6ES	
W 20 ES-U 11	B6ES-11	
W 20 ET	BPR6EK-A	
W 20 ETL	BPR6EKN	
W 20 ETR	BPR6EK-A	
W 20 ETR-L	BPR6EKN	
W 20 ETR-L 8	BPR6EKN	
W 20 ETRS	BPR6EK-A	
W 20 ETS	BPR6EK-A	
W 20 EXR-U	BPR6EY	
W 20 EXR-U 13	BPR6EIX-11	

DENSO	→ NGK	V-Line
W 20 EXR-U11	BPR6EY-11	10
W 20 EXRZ-U	BPR6EIX	
W 20 EX-U	BP6EY	
W 20 EX-U 11	BP6EY-11	
W 20 EX-U 13	BPR6EIX-11	
W 20 EXZ-U	BPR6EIX	
W 20 FP	BP6HS	18
W 20 FPR	BPR6HS	3
W 20 FPR-U	BPR6HS	3
W 20 FP-U	BP6HS	18
W 20 FS	B6HS	
W 20 FSG-U	BR6HIX	
W 20 FS-U	B6HS	
W 20 FSZ-U	BR6HIX	
W 20 S	B6S	
W 20 S-U	B6S	
W 22	B7S	
W 22 EA	B7EM	
W 22 EAR	B7EM	
W 22 EB	BR7ET	
W 22 EBR	BR7ET	
W 22 EDR 14	BR7EQ-14	
W 22 EKR-S 11	BUR7EB-11	
W 22 EK-S 11	BUR7EB-11	
W 22 EP	BP7ES	
W 22 E-P 11	BP7ES-11	
W 22 EPB	BP7ET	
W 22 EPG-U	BPR7EIX	
W 22 EPR	BPR7ES	19
W 22 EPR 11	BPR7ES-11	
W 22 EPR-S 11	BUR7EA-11	
W 22 EPR-U	BPR7ES	19
W 22 EPR-U 11	BPR7ES-11	
W 22 EPRZ-U	BPR7EIX	
W 22 EP-S 11	BUR7EA-11	
W 22 EP-U	BP7ES	
W 22 EP-U 11	BP7ES-11	
W 22 EPZ-U	BPR7EIX	
W 22 ES	B7ES	
W 22 ESG-U	BR7EIX	
W 22 ESL	BR7ES	
W 22 ES-L 11	BUR7EB-11	
W 22 ESR	BR7ES	
W 22 ESRL	BR7ES	
W 22 ESR-L 11	BUR7EB-11	
W 22 ESR-U	BR7ES	
W 22 ES-U	B7ES	
W 22 ES-U 11	B7ES-11	
W 22 ESZ-U	BR7EIX	
W 22 ETL	BPR7EKN	
W 22 ETRL	BPR7EKN	
W 22 ETR-L 8	BPR7EKN	





DENSO	→ NGK	V-Line
W 22 EXR-U	BPR7EIX	
W 22 EXR-U 11	BPR7EY-11	
W 22 EX-U	BP7EY	
W 22 FP	BP7HS	
W 22 FPR	BPR7HS	
W 22 FPR-U	BPR7HS	
W 22 FPRZ-U	BPR7HIX	
W 22 FP-U	BP7HS	
W 22 FPUS	BP7HS	
W 22 FS	B7HS	
W 22 FSG-U	BR7HIX	
W 22 FSR	BR7HS	
W 22 FSR-U	BR7HS	
W 22 FS-U	B7HS	
W 22 FSZ-U	BR7HIX	
W 22 S	B7S	
W 22 S-U	B7S	
W 24	B8S	
W 24 EP	BP8ES	
W 24 E-P 11	BP8ES	
W 24 EPR	BPR8ES	
W 24 EPR-U	BPR8ES	
W 24 EPRZ-U	BPR8EIX	
W 24 EP-U	BP8ES	
W 24 ES	B8ES	
W 24 ESG-U	BR8EIX	
W 24 ESR	BR8ES	
W 24 ESRZ-U	BR8EIX	
W 24 ES-U	B8ES	
W 24 ES-U 11	B8ES	
W 24 ESV	B8EG	
W 24 ESZ-U	BR8EIX	
W 24 FS	B8HS	
W 24 FSG-U	BR8HIX	
W 24 FS-U	B8HS	
W 24 FSZ-U	BR8HIX	
W 24 S	B8S	
W 24 S-U	B8S	
W 25 EB	BR8ET	
W 25 EBR	BR8ET	
W 25 EDR	BR8EQ	
W 25 EDR 14	BR8EQ-14	
W 25 EN	B8EG	
W 25 EPT	BR8EIX	
W 25 FN	BR8HIX	
W 27 EBR	BR9ET	
W 27 EDR	BR9EQ-14	
W 27 EDR 14	BR9EQ-14	
W 27 EPT	BR9EIX	
W 27 ES	B9ES	
W 27 ESG-U	BR9EIX	
W 27 ESRZ-U	BR9EIX	

DENSO	→ NGK	V-Line
W 27 ES-U	B9ES	
W 27 ESZ-U	BR9EIX	
W 27 FS	B9HS	
W 27 FS-U	B9HS	
W 29 EBR	BR10ET	
W 29 ESG-U	BR10EIX	
W 29 ESZ-U	BR10EIX	
W 31 EPT	R7376-10	
W 31 ESG-U	BR10EIX	
W 31 ESRZ-U	BR10EIX	
W 31 ESZ-U	BR10EIX	
W 34 ESZ-U	BR10EIX	
X 22 EPRGL	PJR7A	
X 22 GPR-U	DPR7Z	
X 22 GP-U	DPR7Z	
X 24 ESG-U	DR8EIX	
X 24 ESRZ-U	DR8EIX	
X 24 ESRZ-U 9	DR8EIX	
X 24 ESZ-U	DR8EIX	
X 24 ESZ-U 9	DR8EIX	
X 27 ESRZ-U	DR9EIX	
X 27 ESRZ-U 9	DR9EIX	
X 27 ES-U	D9EA	
X 27 ESZ-U	DR9EIX	
X 27 ESZ-U 9	DR9EIX	
X 29 ESZ-U	DR9EIX	
XE 20 HR-U 9	LZKAR7A	54
XU 20 EPR-U	DCPR6E	
XU 22 EPP	DCPR7EIX	
XU 22 EPR	DCPR7E	
XU 22 EPRP	DCPR7EIX	
XU 22 EPR-U	DCPR7E	
XU 22 EPRZ-U	DCPR7EIX	
XU 22 EP-U	DCP7E	
XU 22 EPZ-U	DCPR7EIX	
XU 22 HDR 9	LKR7B-9	
XU 22 PR 9	DCPR7EA-9	
XU 24 EPRP	DCPR8EIX	
XU 24 EPR-U	DCPR8E	
XU 24 EPRZ-U	DCPR8EIX	
XU 24 EP-U	DCPR8E	
XU 24 EPZ-U	DCPR8EIX	
XU 27 EPR-U	DCPR9E	
XU 27 EPRZ-U	DCPR9EIX	
ZC 20 HPR 11	ILKAR7L11	
ZXU 20 PR 11	IKR6G11	
ZXU 22 PR 11	IKR6G11	
ENKER	→ NGK	V-Line
F 100 C	B8HS	
F 50 C	B5HS	
F 55 CP	BP5HS	
F 65 CP	BP6HS	18



ENKER	→ NGK	V-Line
F 75 C	B6HS	
F 80 C	B7HS	
F 85 CP	BP7HS	
FA 50	B-4L	
FA 70	B-6L	
FE 100 C	B9ES	
FE 35 CP	BP4ES	
FE 45 CP	BP5ES	8
FE 50 C	B5ES	
FE 55 CP	BP5ES	8
FE 55 CPD	BP5ET	
FE 65 CP	BP6ES	4
FE 65 CPD	BUR6ET	1
FE 70 C	B6ES	
FE 75 C	B7ES	
FE 80 C	B8ES	
FE 85 CP	BP7ES	
FE 85 CPD	BP7ET	
FE 85 CPU	BP7ET	
FE 95 CP	BP8ES	
FET 65 CP	BP5EFS	
FET 75 CP	BP6EFS	5
FS 30	B-4	
FS 70	B6S	
FS 75 C	B7S	
FS 80	B8S	
FT 45 CP	BP5FS	
FT 55 CP	BP6FS	
FT 85 CP	BP7FS	
M 60	AB-6	
M 75	AB-7	
M 80	AB-8	
MT 45 CP	AP5FS	
MT 55 CP	AP6FS	
MT 65 CP	AP7FS	
SFE 55 CP	BKR5ES	35
SFE 65 CP	BKR6ES	28
SFE 65 CPD	BCP6ET	
SFE 65 CPR	BPR5ES	6
SFE 85 CP	BCPR7ES	
SFE 85 CPD	BCP7ET	
EYQUEM	→ NGK	V-Line
0911007486	ILKER7A8EGS	
30 AM	B-4L	
50 AM	B-6L	
50 M	B5HS	
70 M	B6HS	
75 LM	B6ES	
75 M	B6HS	
100 M	B8HS	
300 AM	B-4L	
406	BP6HS	18

EYQUEM	→ NGK	V-Line
450 JS	BPR4FS-15	
450 L	B5ES	
500 AM	B-6L	
500 C	B6S	
500 CM	B6S	
500 JS	BPR4FS	
500 M	B5HS	
505 JS	BP5FS	
550 LS	BP5ES	8
580 LS	BP5ES	8
600 JS	BPR6FS	
600 L	B6ES	
600 LS	BP6ES	4
600 S	BP5HS	
700	B6HS	
700 CM	B6S	
705 JS	BP7FS	
705 L	B6ES	
705 S	BP6HS	18
707 LS	BP6ES	4
750	BP6HS	18
750 L	B6ES	
750 LJS	BP6EFS	5
750 LS	BP6ES	4
753 LJS	BP6EFS	5
755	B6HS	
755 CM	B6S	
755 L	B6ES	
755 LJS	BP6EFS	5
755 LS	BP6ES	4
755 M	B6HS	
755 S	BP6HS	18
775 SX	BP6HS	18
775 X	B6HS	
800 L	B6ES	
800 LJS	BP6EFS	5
800 LS	BP6ES	4
802 L	B6ES	
803 LJS	BP6EFS	5
805 L	B6ES	
805 LJS	BP7EFS	
805 LJSP	TR7IX	
805 LP	BR8EIX	
850	B7HS	
850 LS	BP7ES	
883 LJP	B8EFS	
1000	B8HS	
1000 CM	B7S	
1000 L	B8ES	
1000 M	B8HS	
1100	B9HS	
1100 L	B8ES	



EYQUEM	→ NGK	V-Line
1150 L	B9ES	
A 558	ILKER7A8EGS	
C 32	B5HS	
C 32 LS	BP5ES	8
C 32 S	BP5HS	
C 42 LJS 3	BP6EFS	5
C 42 S	BP6HS	18
C 52 LS	BP5ES	8
C 62	B7HS	
C 62 LJS	BP6EFS	5
C 62 LS	BP6ES	4
C 62 LS 3 X	BP5ET	
C 62 S	BP7HS	
C 72 LJS	BP7EFS	
C 72 LS	BP7ES	
C 72 LS 3 X	BUR6ET	1
C 82 LJS	BP7EFS	
C 82 LS	BP7ES	
C 82 LS 3 X	BP7ET	
C 92 LS	BP8ES	
D 1000 L	D9EA	
D 1050 L	D9EA	
FC 42 LS	BCP5ES	16
FC 52 LS	BCP5ES	16
FC 58 LS	BCP6ES	17
FC 62 LS	BCP6ES	17
FC 62 LS 2	BCP6ES	17
FC 62 LS 3	BCP6ET	
FC 62 LS 3 X	BCP6ET	
FC 72 LS	BCP7ES	
FC 82 LS	BCPR7E	
FC 82 LS 1	BCP7ES	
FC 82 LS 2	BCP7ES	
FN 52 LS	BK5ESZ	
K 200 M	AB-6	
K 300 JS	AP5FS	
K 300 M	AB-6	
K 350 JS	AP5FS	
K 450 JS	AP5FS	
K 500 M	AB-6	
K 550 JS	AP6FS	
K 600 M	AB-6	
K 750 M	AB-7	
KC 62 JS	AP6FS	
R 1000 L	BR8ES	
R 850	BR7HS	
RC 32 LS 5	BPR4ES-11	
RC 42 S	BPR6HS	3
RC 52 LS	BPR5EY	9
RC 52 LS 5	BPR5EY-11	
RC 52 LZ 3 EX	BUR5ET	22
RC 52 LZE	ZGR5A	15

EYQUEM	→ NGK	V-Line
RC 58 LZ 3 EX	BUR6ET	1
RC 62 HJSDP	PTR5A-13	25
RC 62 LJS	BPR6EFS	7
RC 62 LS	BPR6ES	2
RC 62 LS 5	BPR6ES-11	13
RC 62 S	BPR7HS	
RC 82 LS	BPR7ES	19
RC 82 LS 5	BPR7EY-11	
RFC 42 LS	BKR5ES	35
RFC 42 LS 2 E	BKR5EK	23
RFC 42 LZ 2 E	BKR6EK	20
RFC 50 LZ 2 E	BKR5EK	23
RFC 52 LS	BKR5ES	35
RFC 52 LS 3	BKR6ETUC	
RFC 52 LS 5	BKR5ES-11	33
RFC 52 LSP	BKR6EK	20
RFC 52 LZ 3 EX	BKUR5ET	29
RFC 52 LZE	ZFR5F	53
RFC 52 LZK	BKR5EZ	36
RFC 57 LS 3	BCPR6ET	
RFC 58 LS	BKR6ES	28
RFC 58 LS 2 E	BKR6EK	20
RFC 58 LS 3	BCPR6ET	
RFC 58 LS 5	BKR6ES-11	14
RFC 58 LSP	BKR6EZ	38
RFC 58 LZ	BKR6EY	
RFC 58 LZ 2	BKR6EKC	26
RFC 58 LZ 2 E	BKR6EK	20
RFC 58 LZ 3 EX	BKUR6ET	27
RFC 58 LZ 5	BKR6EY-11	
RFC 58 LZDP	PFR6G-9	
RFC 58 LZE 5	ZFR6F-11	
RFC 62 LS 3	BKR6ES-11	14
RFC 62 LS 3 X	BCPR6ET	
RFC 62 LS 5	BKR6ES-11	14
RFC 62 LZ 3 X	BKUR7ET	
RFC 82 LS	BCPR7ES	
RFC 82 LS 5	BCPR7ES-11	
RFC LZ 3 X	BKUR7ET	
RFN 52 HZ	LFR5B	46
RFN 52 HZ 3 A	LFR5B	46
RFN 58 HZ	LFR6B	47
RFN 58 LZ	BKR6EK	20
XKC 62 JS	APR6FS	
ISOLATOR	→ NGK	V-Line
7 A	B6HS	
6 B	BP6HS	18
7 B	BP6HS	18
7 D	BP6ES	4
A 5 D	BP7EFS	
A 7 D	BP6EFS	5
FM 14145 / 2	BP5ES	8



ISOLATOR	→ NGK	V-Line
FM 14175 / 2	BP6ES	4
FM 14200 / 2	BP6ES	4
FM 14225 / 2	BP7ES	
M 14145	B5HS	
M 14175	B6HS	
M 14175 / 2	B6ES	
M 14225	B7HS	
M 14240	B8HS	
M 14260	B9HS	
M 18225	AB-7	
M 18240	AB-7	
PM 14225	BP7HS	
U 7 D	BCP6ES	17
U 8 D	BCP5ES	16
ZM 14-260	B8HS	
MAGNETI MARELLI → NGK	V-Line	
061 830 072 304	BCPR7ES	
061 830 085 304	BPR7ES	19
061 830 086 304	BKR6E	28
061 830 175 304	BP7ES	
061 830 176 304	BP6HS	18
061 830 210 304	BP6ES	4
061 830 211 304	BPR6ES	2
061 830 215 304	BP6EFS	5
061 830 254 304	BKR6E	28
061 830 257 304	BPR6HS	3
061 830 258 304	BP5HS	
061 830 262 304	BPR6EFS	7
061 850 023 304	PTR5A-13	25
062 000 611 304	B6HS	
062 000 654 304	BP6HS	18
062 000 739 304	BP6ES	4
062 000 740 304	BPR6ES	2
062 000 754 304	BP6HS	18
7 LCR	BKR6E	28
7 LPR	BKR6E	28
8 LCR	BCPR7ES	
8 LDCR	PTR5A-13	25
8 LPR	BCPR7ES	
CM 3 N	AB-6	
CM 4 N	AB-6	
CM 5 N	AB-6	
CM 6 N	AB-7	
CW 10 L	B8EG	
CW 101 L	BR9EIX	
CW 225 A	B6HS	
CW 250 A	B7HS	
CW 260 N	B7HS	
CW 3 C	B-4	
CW 3 CJ	B-4	
CW 4 A	B5ES	
CW 4 C	B-4	

MAGNETI MARELLI → NGK	V-Line	
CW 4 CJ	B-4	
CW 4 LP	BP4ES	
CW 5 C	B-4	
CW 5 L	B5ES	
CW 5 LJ	B5ES	
CW 5 LP	BP5ES	8
CW 5 LS	B5ES	
CW 5 LSZ	B5ES	
CW 5 N	B5HS	
CW 5 NJ	B5HS	
CW 5 NP	BP5HS	
CW 5 NS	B5HS	
CW 5 NSZ	B5HS	
CW 55 N	B5HS	
CW 6 C	B6S	
CW 6 CJ	B6S	
CW 6 L	B5ES	
CW 6 LJ	B5ES	
CW 6 LP	BP5ES	8
CW 6 LR	BR5ES	
CW 6 LS	B5ES	
CW 6 LSZ	B5ES	
CW 6 N	B6HS	
CW 6 NJ	B6HS	
CW 6 NP	BP6HS	18
CW 6 NPR	BPR6HS	3
CW 67 L	B6ES	
CW 67 LP	BP6ES	4
CW 67 N	BP6HS	18
CW 67 NJ	B6HS	
CW 67 P	BP5ES	8
CW 7 C	B6S	
CW 7 L	B6ES	
CW 7 LCR	BKR6E	28
CW 7 LJ	B6ES	
CW 7 LP	BP6ES	4
CW 7 LPH	BP6ES	4
CW 7 LPR	BPR6ES	2
CW 7 LR	BR6ES	
CW 7 N	B6HS	
CW 7 NJ	B6HS	
CW 7 NP	BP6HS	18
CW 7 NPR	BPR6HS	3
CW 75 LP	BP6ES	4
CW 78 L	B6ES	
CW 78 LP	BP6ES	4
CW 78 LPR	BPR6ES	2
CW 78 LPS	BP6ES	4
CW 8 CJ	B7S	
CW 8 L	B7ES	
CW 8 LCR	BCPR7ES	
CW 8 LJ	B7ES	



MAGNETI MARELLI → NGK		V-Line
CW 8 LP	BP7ES	
CW 8 LPR	BPR7ES	19
CW 8 LPS	BP7ES	
CW 8 N	B7HS	
CW 8 NP	BP7HS	
CW 8 NR	BR7HS	
CW 89 LP	BP7ES	
CW 9 L	B8ES	
CW 9 LJ	B8ES	
CW 9 LP	BP8ES	
CW 9 N	B8HS	
CWC 12 NJ	B8HS	
CWC 6 NJ	B6HS	
CWC 67 NJ	B6HS	
CWC 7 NJ	B6HS	
CWC 9 NJ	B7HS	
CWF 11 L	BR8EIX	
CWP 10 L	BR9EIX	
CWP 11 L	BR10EIX	
CWP 5 N	BR6HIX	
CWP 6 N	BR6HIX	
CWP 7 N	BR6HIX	
CWP 8 L	BR7EIX	
CWP 8 N	BR7HIX	
CWP 9 L	BR8EIX	
CWP 9 N	BR8HIX	
F 6 NC	BP5HS	
F 6 NCR	BPR5HS	
F 7 LC	BP6ES	4
F 7 LCR	BPR6ES	2
F 7 NC	BP6HS	18
F 7 NCR	BPR6HS	3
F 8 LC	BP7ES	
F 8 LCR	BPR7ES	19
FC 6 N	B5HS	
FC 7 N	B6HS	
FC 9 L	BP8ES	
T 7 LC	BP6EFS	5
T 7 LCR	BPR6EFS	7
T 8 LC	BP7EFS	
TM 2 NP	AP5FS	
TM 4 NP	AP6FS	
TW 4 LP	BP5EFS	
TW 5 NP	BP5FS	
TW 6 NP	BP6FS	
TW 7 LP	BP6EFS	5
TW 7 LPR	BPR6EFS	7
TW 7 NP	BP6FS	
TW 78 LP	BP6EFS	5
TW 78 LPR	BPR6EFS	7
TW 78 NPR	BPR6FS	

MARCHAL / VALEO → NGK		V-Line
2 / 32 H	B8ES	
2 / 33 H	B7ES	
4 N	B7HS	
5 H	B7ES	
5 N	BP6HS	18
5 NCYCLO	BP6HS	18
6 H	BP7ES	
6 N	BP5HS	
7 H	BP6ES	4
8 H	BP6ES	4
9 H	BP5ES	8
11 720	B8HS	
12 086	B8HS	
17 C	AB-7	
19 C	AB-7	
19 E	AB-7	
19 L	AB-7	
20 C	AB-6	
20 E	AB-6	
20 L	AB-6	
21 C	AB-6	
21 E	AB-6	
21 L	AB-6	
23 F	A6FS	
34 / 5 HS	BP6ES	4
34 C	B7S	
34 CM	B7S	
34 HS	B7ES	
34 HSM	B7ES	
34 S	B7HS	
35	B6HS	
35 / 1	BP6HS	18
35 / 1 B	BP6HS	18
35 / 1 D	BP6HS	18
35 / 36 D	B6HS	
35 / 36 P	B6HS	
35 / 36 R	B6HS	
35 B	B6HS	
35 C	B6S	
35 CM	B6S	
35 HA	BP6ES	4
35 HS	B6ES	
35 M	B6HS	
35 P	B6HS	
36	B5HS	
36 B	B5HS	
36 C	B-4	
36 CM	B-4	
36 D	B5HS	
36 HS	B5ES	
36 M	B5HS	
36 P	B5HS	



MARCHAL / VALEO → NGK	V-Line	
37 S	B5HS	
41 306	AB-8	
64 H	BP7ES	
67 HP	BR8EIX	
70 H	BP6ES	4
76 H	BP5ES	8
84 H	BP5ES	8
88 N	B5HS	
C 64 H	BP6EFS	5
C 68 H	BP6EFS	5
C 7 H	BP6EFS	5
F 70 H	BCP7ES	
F 74 H	BCP6ES	17
F 80 H	BCP7ES	
GT 34	BP7HS	
GT 34 / 2 H	BP6ES	4
GT 34 / 5	BP6HS	18
GT 34 / 5 D	BP6HS	18
GT 34 / 5 H	BP6ES	4
GT 34 / 5 HA	BP6ES	4
GT 34 / 5 HD	BP6ES	4
GT 34 D	BP7HS	
GT 34 H	BP7ES	
GT 34 HD	BP6ES	4
GT 35	BP5HS	
GT 35 D	BP5HS	
GT 35 H	BP5ES	8
GT 35 HD	BP5ES	8
H 33 RG	B8EG	
H 34 F	B8ES	
HA 32 / 2	B8ES	
HF 34	B7ES	
HF 34 F	B8ES	
RR 32 HS	BR9EIX	
RR 33 HSS	BR8EIX	
SCGT 34 / 5H	BP6EFS	5
SCGT 35 H	BP6EFS	5
V 36 A	B5HS	
V 6 NSOLEX	B5HS	
MOTORCRAFT → NGK	V-Line	
1 Y 0 A	BKR6E-11	14
1 Y 0 B	BKR7E-11	
1 Y 0 F	DCPR7E	
1 Y 0 G	ZFR5F-11	40
1 Y 0 H	ZFR6F-11	
1 Y 0 K	BPR5ES-13	
1 Y 0 L	BRE527Y-11	
1 Y 00	BPR5ES	6
1 Y 01	BPR6ES	2
1 Y 03	BPR5ES-11	
1 Y 06	BKR5E	35
1 Y 07	BKR6E	28

MOTORCRAFT → NGK	V-Line	
1 Y 09	BKR5E-11	33
1 YR 7	BKR6EIX-P	
1 YR 9	BKR5EIX-11P	
1 YRA	BKR6EIX-11P	
1 YRF	DCPR7EIX-P	
1 YRG	ZFR5FIX-11P	
1 YRH	ZFR6FIX-11P	
A 1	B8S	
A 1 CU	B8S	
A 1 X	B8S	
A 2	B7S	
A 2 X	B7S	
A 3	B6S	
A 3 CU	B6S	
A 3 X	B6S	
A 4	B6S	
A 5	B6S	
A 5 CU	B6S	
A 5 X	B6S	
A 7	B-4	
A 7 U	B-4	
A 7 X	B-4	
A 9	B-4	
A 9 X	B-4	
A 901	B8S	
A 21 X	B8S	
AE 1 C	B7HS	
AE 1 X	B7HS	
AE 2	B7HS	
AE 2 C	B7HS	
AE 2 X	B7HS	
AE 3	B6HS	
AE 3 C	B6HS	
AE 3 X	B6HS	
AE 4	B5HS	
AE 4 X	B5HS	
AE 6	B5HS	
AE 22	BP6HS	18
AE 22 C	BP6HS	18
AE 32	BP6HS	18
AE 32 C	BP6HS	18
AE 42	BP5HS	
AE 52	BP5HS	
AE 62	BP5HS	
AE 901	B9HS	
AER 32	BPR6HS	3
AF 12	BP7FS	
AF 22	BP6FS	
AF 32	BP6FS	
AF 42	BP5FS	
AF 52	BP4FS	
AG 1	B8ES	





MOTORCRAFT	→ NGK	V-Line
AG 1 C	B8ES	
AG 1 X	B8ES	
AG 2	B7ES	
AG 2 C	B7ES	
AG 2 CU	B7ES	
AG 2 X	B7ES	
AG 3	B6ES	
AG 3 C	B6ES	
AG 3 X	B6ES	
AG 4	B5ES	
AG 5	B5ES	
AG 5 CU	B5ES	
AG 7	B5ES	
AG 12	BP7ES	
AG 12 C	BP7ES	
AG 12 CU	BP7ES	
AG 22	BP6ES	4
AG 22 C	BP6ES	4
AG 22 CU	BP6ES	4
AG 25 C	B7EM	
AG 32 A	BP6ES	4
AG 32 C	BP6ES	4
AG 32 CU	BP6ES	4
AG 34 CU	BP6EY	
AG 34 CU 11	BP6EY-11	
AG 42	BP5ES	8
AG 42 CU	BP5ES	8
AG 44	ZGR5C	
AG 44 CU	BP5EY	
AG 52	BP5ES	8
AG 54	ZGR5C	
AG 54 CU	BP4EY	
AG 82	BP4ES	
AG 224	BP6ES-11	
AG 252	BP6ES	4
AG 252 C	BP6ES	4
AG 403	R7376-10	
AG 403 C	R7376-10	
AG 501 X	BR10EIX	
AG 603	BR9EIX	
AG 603 C	BR9EIX	
AG 701	B9ES	
AG 701 C	B9ES	
AG 701 CU	B9ES	
AG 701 X	BR9EIX	
AG 901	B9ES	
AG 901 C	B9ES	
AG 901 CU	B9ES	
AG 901 X	BR8EIX	
AG 902	BP8ES	
AG 903	B8EG	
AGF 12	BP7EFS	

MOTORCRAFT	→ NGK	V-Line
AGF 12 C	BP7EFS	
AGF 22 C	BP6EFS	5
AGF 32 CU	BP6EFS	5
AGFS 22 C 1	BPR6EFS	7
AGFS 22 FE 1	PTR6F-13	
AGFS 22 FE 13 J	PTR6D-13G	
AGFS 22 IPJ	ITR6F13	
AGFS 22 YPC	ITR6F13	
AGFS 32 C 1	BPR6EFS	7
AGN 42	BP5ES	8
AGP 12 C	BCP7ES	
AGP 22 C	BCP6ES	17
AGP 701 C	R7436-10	
AGPR 12 C	BCPR7ES	
AGPR 12 P	BKR7EIX-11	
AGPR 12 PP	PFR7B-11	
AGPR 12 PP 11	PFR7B-11	
AGPR 12 PP 8	PFR7B	
AGPR 22 C	BKR6ES	28
AGPR 22 C 1	BKR6ES-11	14
AGPR 22 CD	BKR6ES	28
AGPR 22 CD 1	BKR6ES-11	14
AGPR 22 P	BKR6EIX-11	
AGPR 22 PP	PFR6B-11	
AGPR 22 PPJ	PFR6B-11	
AGPR 32 C	BKR6ES	28
AGPR 32 CD 1	BKR6ES-11	14
AGPR 32 PD	BKR5EKUP	
AGPR 902 C	BCPR9ES-11	
AGPR 902 P	R7436-9	
AGPS 12 C	BCPR7ES	
AGPS 12 P 1	BKR7EIX-11	
AGPS 22 C	BKR6ES	28
AGPS 22 C 1	BKR6ES-11	14
AGPS 22 P	BKR6EIX-11	
AGPS 22 P 1	BKR6EIX-11	
AGPS 22 PP 1	PFR6B-11	
AGPS 32 C	BKR6ES	28
AGPS 32 C 1	BKR6ES-11	14
AGPS 44 F	PZFR5D-11	34
AGPS 44 F 11	PZFR5D-11	34
AGPS 44 F 11 J	PZFR5D-11	34
AGR 1 X	BR8ES	
AGR 2 C	BR7ES	
AGR 3 X	BR6ES	
AGR 12 C	BPR7ES	19
AGR 16 C	BR8ET	
AGR 21	BR6ES	
AGR 22	BPR6ES	2
AGR 22 C	BPR6ES	2
AGR 22 CU	BPR6ES	2
AGR 31	BR6ES	



MOTORCRAFT	→ NGK	V-Line
AGR 32	BPR6ES	2
AGR 32 C	BPR6ES	2
AGR 32 CU	BPR6ES	2
AGR 34 CU	BPR6EY	
AGR 41	BR5ES	
AGR 42	BPR5ES	6
AGR 42 C	BPR5ES	6
AGR 42 CU	BPR5ES	6
AGR 44 CU	BPR5EY	9
AGR 44 CU 11	BPR5EY-11	
AGR 51	BR5ES	
AGR 52	BPR5ES	6
AGR 54 CU	BPR5EY	9
AGR 82	BPR4ES	
AGR 701 X	BR9EIX	
AGR 901 X	BR8EIX	
AGRF 22	BPR6EFS	7
AGRF 22 C	BPR6EFS	7
AGRF 22 C 1	BPR6EFS	7
AGRF 22 PP 1	PTR5D-10	31
AGRF 32	BPR6EFS	7
AGRF 32 C 1	BPR6EFS	7
AGRF 226	BPR6EFS-13	
AGRF 326	BPR6EFS-13	
AGRF 42	BPR5EFS	
AGRF 52	BPR5EFS	
AGRP 52	ZFR4F-11	
AGS 22 C	BPR6ES	2
AGS 32 C	BPR5ES	6
AGS 32 C 11	BPR5ES-11	
AGS 42 CC	BPR4ES	
AGSF 22 FM 1	TR5IX	
AGSF 22 FSCM	PTR6D-13G	
AGSF 22 PGM	PTR6F-13	
AGSF 22 PM	PTR6F-13	
AGSF 22 PP	PTR6F-13	
AGSF 22 PPJ	PTR6F-13	
AGSF 22 PPM	PTR6F-13	
AGSF 22 WM	BPR5EFS	
AGSF 22 YPC	ITR6F13	
AGSF 24 C	TR5-1	
AGSF 24 N	TR55-1	
AGSF 32 C	BPR5EFS	
AGSF 32 FEM	PTR5D-10	31
AGSF 32 FM	PTR5D-13	
AGSF 32 W	TR55IX	
AGSF 32 WM	ITR6F13	
AGSF 32 YPC	TR5AI-13	
AGSF 34 C	TR5-1	
AGSP 32	BKR6ES-11	14
AGSP 32 C	BKR6ES-11	14
AGSP 32 FP	PFR5G-11	

MOTORCRAFT	→ NGK	V-Line
AGSP 32 PR	PFR6B-11	
AGSP 33 C	ZFR6F-11	
AGSP 52	BKR5ES	35
AL 5	B-6L	
AL 5 X	B-6L	
AL 7	B-6L	
AL 7 U	B-6L	
AL 7 X	B-6L	
AL 9	B-4L	
AL 9 X	B-4L	
AL 11	B-4L	
ARF 22	BPR6FS	
ARF 22 C	BPR6FS	
ARF 22 CU	BPR6FS	
ARF 32	BPR6FS	
ARF 32 C 6	BPR6FS	
ARF 32 M	BPR6FS	
ARF 52	BPR4FS	
ARF 62	BPR4FS	
ASF 32	BPR6FS	
ASF 32 C	BPR6FS	
ASF 32 M	BPR6FS	
ASF 32 P	UR5IX	
ASF 42	BPR5FS-11	
ASF 42 C	BPR5FS-11	
ASF 42 P	UR4IX	
ARF 326	BPR6FS	
ARF 426	BPR5FS-15	
ARF 526	BPR4FS-15	
ARF 626	BPR4FS-15	
ASF 44 P	UR4IX	
ASF 52	BPR4FS	
ASF 426 C	BPR5FS-15	
ASF 526	BPR4FS-15	
AT 1	B8S	
AT 2	B7S	
AT 3	B6S	
AT 4	B6S	
AT 4 A	B6S	
AT 6	B6S	
AT 8	B-4	
ATL 3	B-6L	
ATL 4	B-6L	
ATL 8	B-4L	
AV 1 X	B8HS	
AV 2 CU	B7HS	
AV 2 X	B7HS	
AV 22 CU	BP6HS	18
AV 3 CU	B6HS	
AV 4	B5HS	
AV 42	BP5HS	
AV 52	BP5HS	





MOTORCRAFT	→ NGK	V-Line
AV 901 CU	B9HS	
AWRF 32	BPR6EFS	7
AWRF 42	BPR5EFS	
AWRF 325	BPR6EFS-13	
AWSF 22 C	BPR6EFS	7
AWSF 22 E	TR6IX	
AWSF 22 F	PTR6D-13	
AWSF 22 FM	TR5IX	
AWSF 22 FM 1	TR5IX	
AWSF 22 FS	PTR6D-13G	
AWSF 24 C	TR5-1	
AWSF 32	BPR6EFS	7
AWSF 32 C	BPR6EFS	7
AWSF 32 E	TR55IX	
AWSF 32 EE	TR55IX	
AWSF 32 F	PTR5D-10	31
AWSF 32 FM	TR5IX	
AWSF 32 P	TR5IX	
AWSF 32 PM	TR5IX	
AWSF 32 PP	TR5IX	
AWSF 34	TR5-1	
AWSF 34 C	TR5-1	
AWSF 34 PP	TR5-1IX	
AWSF 42	BPR5EFS	
AWSF 42 C	BPR5EFS	
AWSF 42 EE	TR55IX	
AWSF 42 PP	TR55IX	
AWSF 44 C	TR5-1	
AWSF 52 C	BPR5EFS	
AWSF 54	TR5-1	
AWSF 54 C	TR5-1	
AWSFA 32 C	BPR5EFS	
AYFS 22 C	PTR5A-13	25
AYFS 22 FE 1 J	PLTR6A-10G	
AYFS 22 FPM 1	PTR5A-13	25
AYFS 22 PP	PTR5A-13	25
AYFS 22 PP 1	PTR5A-13	25
AYFS 32 CJ	TR5B-13	45
AYRF 22 P	PTR5A-13	25
AYRF 22 PP	PTR5A-13	25
AYSF 32 YPC	ILTR5A-13G	
AZ 2	B7S	
AZ 3	B6S	
AZ 9	B-4	
AZ 901	B8S	
AZFS 22 C	PTR5A-13	25
AZFS 22 PP	PTR5A-13	25
AZFS 32 FE	PTR5A-13	25
B 2	AB-8	
B 2 W	AB-8	
B 3 W	AB-7	
B 3 X	AB-7	

MOTORCRAFT	→ NGK	V-Line
B 4	AB-7	
B 4 X	AB-7	
B 6	AB-6	
B 6 W	AB-6	
B 8	AB-6	
B 8 X	AB-6	
B 9	AB-6	
BF 1	A7FS	
BF 12	AP8FS	
BF 22	AP6FS	
BF 22 C	AP6FS	
BF 22 CU	AP6FS	
BF 22 CX	AP6FS	
BF 22 X	AP6FS	
BF 3	A6FS	
BF 32	AP6FS	
BF 32 CU	AP6FS	
BF 32 CX	AP6FS	
BF 32 X	AP6FS	
BF 42	AP5FS	
BF 42 CU	AP5FS	
BF 82	AP5FS	
BF 901	A8FS	
BF 92	AP5FS	
BFS 22 C	APR6FS	
BFS 32 C	APR6FS	
BFS 32 C 1	APR6FS	
BR 8	AB-6	
BRF 22	APR6FS	
BRF 22 C	APR6FS	
BRF 3 M	AR6FS	
BRF 31	AR6FS	
BRF 314	AR6FS	
BRF 32	APR6FS	
BRF 42	APR5FS	
BRF 82	APR5FS	
BSF 31	AR6FS	
BSF 314	AR6FS	
BSF 82	APR5FS	
BSF 92	APR5FS	
BT 2	AB-8	
BT 3	AB-7	
BT 4	AB-7	
BT 6	AB-6	
BT 8	AB-6	
BT 9	AB-6	
BT 10	AB-6	
BTF 1	A7FS	
BTF 3	A6FS	
BTF 31	A6FS	
BTF 42	AP5FS	
BTF 6	A6FS	



MOTORCRAFT	→ NGK	V-Line
BTRF 42	APR5FS	
BZ 8	AB-6	
PRESTOLITE ELECTRIC	→ NGK	V-Line
14 2 X	B6S	
14 3	B6S	
14 3 X	B6S	
14 4	B6S	
14 5	B6S	
14 5 X	B6S	
14 7	B-4	
14 7 X	B-4	
14 9	B-4	
14 9 X	B-4	
14 E 1	B8HS	
14 E 2	B7HS	
14 E 22	BP7HS	
14 E 3	B6HS	
14 E 32	BP6HS	18
14 E 4	B5HS	
14 E 42	BP6HS	18
14 E 52	BP5HS	
14 E 6	B5HS	
14 E 62	BP5HS	
14 F 22	BP6FS	
14 F 32	BP6FS	
14 F 42	BP5FS	
14 F 52	BPR4FS	
14 G 1	B8ES	
14 G 12	BP8ES	
14 G 2	B7ES	
14 G 22	BP6ES	4
14 G 3	B6ES	
14 G 32	BP5ES	8
14 G 4	B6ES	
14 G 42	BP5ES	8
14 G 5	B5ES	
14 G 52	BP5ES	8
14 G 7	B5ES	
14 G 82	BP4ES	
14 G 902	BP8ES	
14 GF 22	BP6EFS	5
14 GR 22	BPR6ES	2
14 GR 32	BPR5ES	6
14 GR 4	BR6ES	
14 GR 42	BPR5ES	6
14 GR 52	BPR4ES	
14 GR 52 A	BPR4ES-11	
14 GR 526	BPR4ES-11	
14 GR 53	ZGR5C	
14 GR 7	BR5ES	
14 GRF 22	BPR6EFS	7
14 GRF 32	BPR5EFS	

PRESTOLITE ELECTRIC	→ NGK	V-Line
14 GRF 52	BPR5EFS	
14 L 4	B-6L	
14 L 7	B-6L	
14 L 9	B-4L	
14 R 8	B6S	
14 RF 22	BPR6FS	
14 RF 32 A	BPR5FS-15	
14 RF 326	BPR5FS-15	
14 RF 42 A	BPR5FS-15	
14 RF 426	BPR5FS-15	
14 RF 52	BPR4FS	
14 RF 52 A	BPR4FS-15	
14 RF 526	BPR4FS-15	
14 RF 62	BPR4FS	
14 RF 62 A	BPR4FS-15	
14 RF 626	BPR4FS-15	
18 10	AB-6	
18 3	AB-6	
18 4	AB-6	
18 8	AB-6	
18 9	AB-6	
18 F 22	AP6FS	
18 F 3	A6FS	
18 F 32	AP6FS	
18 F 42	AP5FS	
18 F 6	A6FS	
18 F 82	AP5FS	
18 RF 3	AR6FS	
18 RF 32	APR6FS	
18 RF 42	APR6FS	
18 RF 82	APR6FS	
TORCH	→ NGK	V-Line
5 580	BUR6ET	1
8 012	BPR6EIX	
DK 7 RTC	DCPR7E	
E 5 RTC	BPR5HS	
E 5 TC	BP5HS	
E 6 RTC	BPR6HS	3
E 7 C	B6HS	
E 7 RTC	BPR7HS	
E 7 TJC	BUR6ET	1
F 5 RF	BPR5EY	9
F 5 RTC	BPR5ES	6
F 5 TC	BP5ES	8
F 6 RF	BPR6EY	
F 6 RTC	BPR6ES	2
F 6 T	BP6ES	4
F 7 C	B7ES	
F 7 RC	BR7ES	
F 7 RTC	BPR7ES	19
F 7 RTJC	BUR6ET	1
F 8 RC	BR8ES	



TORCH	→ NGK	V-Line
F 8 RTC	BP8ES	
K 4 RTC 3	ZFR5F	53
K 5 RF 11	BKR5E-11	33
K 5 RTC 11	BKR5ES-11	33
K 5 RTS	ZFR5P-G	41
K 5 TC	BKR5ES-11	33
K 6 RF	BKR6ES	28
K 6 RF 11	BKR6E-11	14
K 6 RTC	BKR5E-11	33
K 6 RTC 11	BKR6ES-11	14
K 7 RTC	BKR6ES	28
K 7 TC	BCP6ES	17
K 7 TJC	BCP6ET	
K5RTC	BCPR5ES	32
K5RTC	BKR5ES	35
P 5 TC	BP5FS	
P 6 RTC	BPR6FS	
P 6 TC	BP6FS	
P 7 RTC	BP7FS	
P 7 TC	BP7FS	
Q 5 RTC	BPR5EFS	
Q 5 TC	BP5EFS	
Q 6 RTC	BPR6EFS	7
Q 6 TC	BP6EFS	5
Q 7 TC	BP5EFS	
T 5 TC	AP5FS	
T 6 RTC	APR6FS	
T 6 TC	AP6FS	
UNIPART, SUREFIRE	→ NGK	V-Line
GSP 130	B5ES	
GSP 131	BP5ES	8
GSP 141	BP5ES	8
GSP 151	BP6ES	4
GSP 160	B6ES	
GSP 163	BP6ES	4
GSP 171	BP6ES	4
GSP 181	BP7ES	
GSP 191	BP8ES	
GSP 2004	ZFR6F-11	
GSP 2007	BKR6ES	28
GSP 244	BPR5ES	6
GSP 263	BPR6ES	2
GSP 264	BPR5ES	6
GSP 281	BPR7ES	19
GSP 30	B6S	
GSP 331	BP5EFS	
GSP 351	BP5EFS	
GSP 361	BP6EFS	5
GSP 381	BP7EFS	
GSP 4154	AP6FS	
GSP 4266	B5HS	
GSP 4352	BP6ES	4

UNIPART, SUREFIRE	→ NGK	V-Line
GSP 4356	BP6HS	18
GSP 4362	BP6ES	4
GSP 4366	BP6HS	18
GSP 4372	BP5ES	8
GSP 4376	BP5HS	
GSP 4382	BP5ES	8
GSP 4452	BPR7ES	19
GSP 4462	BPR6ES	2
GSP 4472	BPR5ES	6
GSP 4552	BCP7ES	
GSP 4562	BCP6ES	17
GSP 4563	BP6EFS	5
GSP 4573	BP5EFS	
GSP 461	BPR6EFS	7
GSP 46515	PTR5A-13	25
GSP 4652	BCPR7ES	
GSP 4662	BKR6ES	28
GSP 4663	BPR6EFS	7
GSP 531	BP5HS	
GSP 540	B5HS	
GSP 541	BP6HS	18
GSP 550	B6HS	
GSP 560	B7HS	
GSP 571	BP7HS	
GSP 634	BKR5ES	35
GSP 6356	BP6HS	18
GSP 6382	BP5ES	8
GSP 6452	BPR7ES	19
GSP 6462	BPR6ES	2
GSP 6468	BPR6ES-11	13
GSP 6472	BPR5ES	6
GSP 664	BKR6ES	28
GSP 665	BCP6ES	17
GSP 6651	PTR5A-13	25
GSP 6652	BKR6ES	28
GSP 6658	BCPR7ES-11	
GSP 6662	BKR6ES	28
GSP 6663	BPR6EFS	7
GSP 6668	BKR6ES-11	14
GSP 684	BCPR7ES	
GSP 685	BCP7ES	
GSP 761	BP6FS	
GSP 881	BPR6FS	
GSP 96 SZ	PFR6N-11	
GSP 9652	PFR6J	
GSP 981	AP6FS	
XL	→ NGK	V-Line
DK 7 RTC	DCPR7E	
DK 7 TC	DCP7E	
E 5 RTC	BPR5HS	
E 5 TC	BP5HS	
E 5 TC-10	BP5HS-10	



XL	→ NGK	V-Line
E 58 C	B5HS	
E 6 C	B6HS	
E 7 C	B7HS	
EL 4 C	B-4L	
F 4 TC-13	BPR4ES-13	
F 5 C	B5ES	
F 5 C-11	B5ES	
F 5 TC-13	BP5ES-13	
F 5 TJC	BP5ET	
F 5 TKC	BPR5EIX-11	
F 6 C-11	BR6ES	
F 6 RTC	BPR6ES	2
F 6 RTC-13	BPR6EIX-11	
F 6 TC-13	BPR6EIX-11	
F 6 TJC	BP6ET	
F 6 TKC	BPR6EK-A	
F 7 C-11	B7ES-11	
F 7 TC-11	BP7ES-11	
F 7 TJC	BP7ET	
F 8 C-11	B8ES	
F 8 JC	BR8ET	
F 8 RC	BR8ES	
F 8 RJC	BR8ET	
G 4 C	B-4	
G 6 C	B6S	
G 7 C	B7S	
G 8 C	B8S	
K 4 RTC-11	BKR4E-11	
K 4 TC	BCPR4ES-11	
K 4 TC-11	BCPR4ES-11	
K 5 LKC	BKR5EKU	
K 5 RFC	BCRE527Y	
K 5 RFKC-11	BKR5EKB-11	
K 5 RLJC	BKUR5ET	29
K 5 TC	BCP5ES	16
K 5 TC-11	BCP5ES-11	
K 6 RLJC-10	BKUR6ET-10	24
K 6 RTJC	BCPR6ET	
K 6 TJC	BCP6ET	
K 7 RLJC	BKUR7ET	
K 7 RLKC	BKR7EKC	
K 7 RTJC	BCPR7ET	
K 7 TC	BCP7ES	
K 7 TC-11	BKR7E-11	
K 7 TJC	BCP7ET	
P 4 TC	BP4FS	
Q 6 RTC	BPR6EFS	7
Q 6 TC	BP6EFS	5
Q 6 TC-13	BP6EFS-13	
T 5 RTC	APR5FS	
T 5 TC	AP5FS	
T 6 RTC	APR6FS	

XL	→ NGK	V-Line
T 6 TC	AP6FS	
U 6 C	AB-6	
U 7 C	AB-7	
UK 6 C	AB-6	
UK 7 C	AB-7	

BERU	→ NGK	D-Power
0 100 220 103	Y-207T	
0 100 220 113	Y-204RS	
0 100 220 114	Y-112M1	
0 100 220 115	Y-112R1	
0 100 220 118	Y-705RS	
0 100 221 102	Y-208T	
0 100 221 103	Y-208T	
0 100 221 105	Y-918J	2
0 100 221 106	Y-208T	
0 100 221 107	Y-924J	1
0 100 221 125	Y-924J	1
0 100 221 132	Y-907R	
0 100 221 133	Y-924J	1
0 100 221 135	Y-924J	1
0 100 221 141	Y-909R	
0 100 221 144	Y-910J	3
0 100 221 145	Y-924J	1
0 100 221 146	Y-910J	3
0 100 221 147	Y-115T1	
0 100 221 148	Y-128T	
0 100 221 149	Y-117RS	
0 100 221 151	Y-118T1	
0 100 221 154	Y-107R	
0 100 221 163	Y-924J	1
0 100 221 170	Y-739R	
0 100 221 186	Y-306R	
0 100 222 101	Y-118R	
0 100 222 106	Y-508J	
0 100 222 301	Y-810	
0 100 222 302	Y-810	
0 100 226 129	Y-729U	34
0 100 226 163	Y-913J	15
0 100 226 164	Y-933J	25
0 100 226 170	Y-712RS	
0 100 226 171	Y-712RS	
0 100 226 173	Y-918J	2
0 100 226 180	Y-146R	
0 100 226 182	Y-147T	
0 100 226 183	Y-115R1	
0 100 226 184	Y-730U	17
0 100 226 185	Y-924J	1
0 100 226 186	Y-924J	1
0 100 226 188	Y-503J	10
0 100 226 189	Y-924J	1
0 100 226 194	Y-707RS	
0 100 226 198	Y-910J	3
0 100 226 206	Y-604J	
0 100 226 207	Y-710J	
0 100 226 208	Y-711J	28
0 100 226 227	Y-732J	4
0 100 226 229	Y-924J	1
0 100 226 233	Y-722JS	

BERU	→ NGK	D-Power
0 100 226 234	Y-916J	6
0 100 226 235	Y-925J	16
0 100 226 237	Y-933J	25
0 100 226 238	Y-740U	22
0 100 226 242	Y-703R	
0 100 226 243	Y-715R	
0 100 226 245	Y-506J	7
0 100 226 246	Y-738U	
0 100 226 249	Y-928U	29
0 100 226 250	Y-929U	41
0 100 226 255	Y-605J	
0 100 226 258	Y-930U	30
0 100 226 299	Y-927J	19
0 100 226 300	Y-748U	14
0 100 226 302	CZ261	
0 100 226 312	Y1038J	
0 100 226 336	Y-701J	39
0 100 226 338	Y-501U	31
0 100 226 343	Y-741U	20
0 100 226 344	Y-504J	24
0 100 226 351	Y-517J	66
0 100 226 352	Y-530J	
0 100 226 354	Y-502R	
0 100 226 362	Y-507J	32
0 100 226 365	Y-746J	38
0 100 226 366	Y-924J	1
0 100 226 371	Y-503J	10
0 100 226 372	Y-747U	26
0 100 226 373	Y-732J	4
0 100 226 375	Y-516J	12
0 100 226 379	Y-745U	11
0 100 226 381	Y-937J	5
0 100 226 384	Y-524J	27
0 100 226 385	Y-548J	75
0 100 226 391	Y-939J	43
0 100 226 392	Y-543J	46
0 100 226 417	Y-523J	37
0 100 226 422	Y-749J	
0 100 226 432	Y-926U	
0 100 226 436	Y-534J	36
0 100 226 475	Y-532J	
0 100 226 480	Y-542J	45
0 100 226 482	Y-741U	20
0 100 226 492	Y1005J	56
0 100 226 494	Y1031J	71
0 100 226 495	Y-603J	60
0 100 226 497	Y-541J	42
0 100 226 504	Y-732J	4
0 100 226 511	Y-733J	13
0 100 226 513	CZ260	
0 100 226 514	CZ259	
0 100 226 517	Y-536J	81



BERU	→ NGK	D-Power
0 100 226 520	Y-904M1	
0 100 226 522	Y-527J	67
0 100 226 525	CZ24	
0 100 226 526	Y-529J	
0 100 226 527	Y-531J	44
0 100 226 538	Y1012J	65
0 100 226 568	Y1013J	63
0 100 226 577	Y1001J1	
0 100 226 639	Y1030J	70
0 100 230 101	Y-181T	
0 100 230 102	Y-162R1	
0 100 230 107	Y-755RS	
0 100 231 104	Y-157R	
0 100 231 107	Y-197R	
0 100 231 109	Y-757RS	
0 100 231 114	Y-197T	
0 100 266 002	Y-547AS	47
0 100 266 008	Y-607AS	50
0 100 266 009	YE14	48
0 100 266 011	Y8002AS	51
0 100 266 016	Y-609AS	49
0 100 266 031	Y9004AS	
0 100 266 032	Y1035AS	77
0 100 266 033	Y1036AS	
0 100 266 034	Y9003AS	78
0 100 266 037	Y1039AS	80
0 100 266 040	Y1002AS	57
0 100 266 068	Y8001AS	58
0 100 266 075	Y1010AS	88
0 100 266 079	Y8010AS	
0 100 276 003	Y8005J	64
0 100 276 004	YE04	40
0 100 276 005	YE12	
0 100 276 008	Y8003J	62
0 100 276 012	YE05	73
0 100 276 014	YE13	
0 100 276 015	YE07	
0 100 276 024	YE08	
0 100 800 031	Y-519J	61
0 100 800 035	CZ258	
0 100 800 036	CZ274	
0 106 671 108	CZ104	52
0 106 671 111	CZ167	91
105 MN	Y-208T	
107 M	Y-810	
107 MJ	Y-810	
108 MJ	Y-810	
141 MJ	Y-207T	
151 MJ	Y-208T	
161 MJ	Y-208T	
162 MJ	Y-207T	
171 MJ	Y-810	

BERU	→ NGK	D-Power
2 510 029 123	Y-606J	
601 MJ	Y-918J	2
602 MJ	Y-208T	
603 MJ	Y-924J	1
609 MJ	Y-924J	1
613 MJ	Y-924J	1
624 MJ	Y-924J	1
631 MJ	Y-907R	
633 MJ	Y-924J	1
636 MJ	Y-924J	1
642 MJ	Y-924J	1
657 MJ	Y-909R	
661 MJ	Y-910J	3
663 MJ	Y-924J	1
666 MJ	Y-910J	3
673 MJ	Y-115T1	
678 MJ	Y-128T	
685 MJ	Y-117RS	
688 MJ	Y-118T1	
705 MJ	Y-107R	
719 MJ	Y-924J	1
730 MJ	Y-739R	
749 MJ	Y-306R	
783 MJ	Y-729U	34
844 MJ	Y-933J	25
852 MJ	Y-913J	15
853 MJ	Y-712RS	
854 MJ	Y-712RS	
855 MJ	Y-732J	4
857 MJ	Y-918J	2
858 MJ	Y-916J	6
860 MJ	Y-930U	30
880 MJ	Y-157R	
886 MJ	Y-146R	
887 MJ	Y-181T	
888 MJ	Y-204RS	
889 MJ	Y-112M1	
890 MJ	Y-162R1	
892 MJ	Y-112R1	
894 MJ	Y-118R	
895 MJ	Y-197R	
897 MJ	Y-147T	
898 MJ	Y-115R1	
905 MJ	Y-730U	17
908 MJ	Y-924J	1
909 MJ	Y-924J	1
912 MJ	Y-503J	10
917 MJ	Y-924J	1
920 MJ	Y-705RS	
921 MJ	Y-707RS	
922 MJ	Y-757RS	
925 MJ	Y-926U	

BERU	→ NGK	D-Power
927 MJ	Y-910J	3
944 MJ	Y-604J	
946 MJ	Y-710J	
947 MJ	Y-711J	28
948 MJ	Y-925J	16
950 MJ	Y-732J	4
954 MJ	Y-924J	1
955 MJ	Y-722JS	
959 MJ	Y-933J	25
961 MJ	Y-929U	41
963 MJ	Y-506J	7
964 MJ	Y-738U	
967 MJ	Y-703R	
968 MJ	Y-715R	
969 MJ	Y-197T	
970 MJ	Y-928U	29
991 MJ	Y-927J	19
999 MJ	Y-740U	22
CGP 002	CZ104	52
CGP 003	CZ304	55
CGP 007	CZ167	91
G 2	Y-924J	1
G 3	Y-924J	1
G 4	Y-907R	
GE 100	Y-607AS	50
GE 101	YE14	48
GE 102	Y-547AS	47
GE 105	Y8002AS	51
GE 108	Y-609AS	49
GE 110	Y1035AS	77
GE 111	Y1036AS	
GE 112	Y9004AS	
GE 114	Y9003AS	78
GE 115	Y1002AS	57
GE 118	Y1039AS	80
GE 121	Y8001AS	58
GE 121 A	Y8001AS	58
GE 122	Y1045AS	89
GE 123	Y8008AS	74
GE 124	Y1010AS	88
GE 125	Y8009AS	
GE 127	Y8010AS	
GE 130	Y1003AS	
GE 133	Y-609AS	49
GE 134	Y8011AS	
GE 135	Y9001AS	72
GN 003	Y-745U	11
GN 005	Y-701J	39
GN 007	Y-741U	20
GN 008	Y-501U	31
GN 010	Y-746J	38
GN 012	Y-502R	

BERU	→ NGK	D-Power
GN 013	Y-924J	1
GN 015	Y-543J	46
GN 016	Y-503J	10
GN 017	Y-747U	26
GN 018	Y-732J	4
GN 019	Y-516J	12
GN 022	Y-937J	5
GN 024	Y-507J	32
GN 026	Y-517J	66
GN 027	Y-504J	24
GN 030	Y-939J	43
GN 033	Y-523J	37
GN 035	Y-749J	
GN 037	Y8005J	64
GN 039	Y-530J	
GN 041	Y-534J	36
GN 042	Y-542J	45
GN 043	Y-532J	
GN 044	Y-755RS	
GN 045	YE12	
GN 046	Y-741U	20
GN 047	YE04	40
GN 053	Y8003J	62
GN 054	Y1005J	56
GN 055	Y1031J	71
GN 056	YE05	73
GN 057	Y-508J	
GN 058	YE13	
GN 059	YE07	
GN 060	Y-536J	81
GN 061	Y-904M1	
GN 062	Y-527J	67
GN 063	YE08	
GN 064	Y-529J	
GN 065	Y-531J	44
GN 067	CZ256	
GN 068	Y-531J	44
GN 070	Y1007J	59
GN 072	CZ258	
GN 074	Y-271-2	
GN 075	CZ256	
GN 095	Y1001J1	
GN 097	Y1030J	70
GN 101	CZ259	
GN 102	CZ260	
GN 103	Y-603J	60
GN 104	Y-541J	42
GN 107	Y-733J	13
GN 108	Y1012J	65
GN 109	Y-519J	61
GN 110	Y1013J	63
GN 116	Y-606J	



BERU	→ NGK	D-Power
GN 117	Y-535J	
GN 119	Y-526J1	69
GN 120	Y1006J	
GN 121	CZ251	76
GN 123	CZ267	90
GN 127	CZ203	68
GN 853	Y-712RS	
GN 854	Y-712RS	
GN 855	Y-732J	4
GN 857	Y-918J	2
GN 858	Y-916J	6
GN 860	Y-930U	30
GN 905	Y-730U	17
GN 908	Y-924J	1
GN 909	Y-924J	1
GN 912	Y-503J	10
GN 917	Y-924J	1
GN 925	Y-926U	
GN 927	Y-910J	3
GN 939	Y-548J	75
GN 944	Y-604J	
GN 948	Y-925J	16
GN 954	Y-924J	1
GN 955	Y-722JS	
GN 959	Y-933J	25
GN 961	Y-929U	41
GN 963	Y-506J	7
GN 964	Y-738U	
GN 970	Y-928U	29
GN 985	Y-605J	
GN 991	Y-927J	19
GN 992	Y-748U	14
GN 993	Y-524J	27
GN 994	CZ261	
GN 997	Y1038J	
GN 999	Y-740U	22
GN 073	CZ274	
GN 106	CZ24	
GN 124	CZ271	
GV 105	Y-208T	
GV 107	Y-810	
GV 108	Y-810	
GV 151	Y-208T	
GV 602	Y-208T	
GV 603	Y-924J	1
GV 624	Y-924J	1
GV 631	Y-907R	
GV 636	Y-924J	1
GV 642	Y-924J	1
GV 657	Y-909R	
GV 661	Y-910J	3
GV 663	Y-924J	1

BERU	→ NGK	D-Power
GV 666	Y-910J	3
GV 673	Y-115T1	
GV 678	Y-128T	
GV 685	Y-117RS	
GV 688	Y-118T1	
GV 705	Y-107R	
GV 719	Y-924J	1
GV 730	Y-739R	
GV 749	Y-306R	
GV 783	Y-729U	34
GV 844	Y-933J	25
GV 852	Y-913J	15
GV 880	Y-157R	
GV 886	Y-146R	
GV 887	Y-181T	
GV 888	Y-204RS	
GV 889	Y-112M1	
GV 890	Y-162R1	
GV 892	Y-112R1	
GV 894	Y-118R	
GV 895	Y-197R	
GV 897	Y-147T	
GV 898	Y-115R1	
GV 917	Y-924J	1
GV 920	Y-705RS	
GV 921	Y-707RS	
GV 922	Y-757RS	
GV 946	Y-710J	
GV 947	Y-711J	28
GV 967	Y-703R	
GV 968	Y-715R	
GV 969	Y-197T	
BOSCH	→ NGK	D-Power
0 250 200 014	Y-810	
0 250 200 020	Y-810	
0 250 200 049	Y-207T	
0 250 200 052	Y-207T	
0 250 200 053	Y-909R	
0 250 200 054	Y-208T	
0 250 200 055	Y-810	
0 250 200 056	Y-208T	
0 250 200 058	Y-208T	
0 250 200 059	Y-208T	
0 250 200 060	Y-208T	
0 250 200 063	Y-207T	
0 250 200 065	Y-208T	
0 250 200 068	Y-208T	
0 250 200 069	Y-924J	1
0 250 200 420	Y-810	
0 250 200 454	Y-208T	
0 250 200 456	Y-208T	
0 250 200 465	Y-208T	

BOSCH	→ NGK	D-Power
0 250 200 468	Y-208T	
0 250 201 001	Y-924J	1
0 250 201 004	Y-918J	2
0 250 201 005	Y-924J	1
0 250 201 006	Y-924J	1
0 250 201 008	Y-924J	1
0 250 201 009	Y-924J	1
0 250 201 011	Y-918J	2
0 250 201 012	Y-909R	
0 250 201 013	Y-924J	1
0 250 201 015	Y-918J	2
0 250 201 017	Y-907R	
0 250 201 019	Y-924J	1
0 250 201 021	Y-918J	2
0 250 201 026	Y-916J	6
0 250 201 027	Y-924J	1
0 250 201 029	Y-913J	15
0 250 201 032	Y-918J	2
0 250 201 033	Y-924J	1
0 250 201 034	Y-909R	
0 250 201 035	Y-930U	30
0 250 201 038	Y-925J	16
0 250 201 039	Y-924J	1
0 250 201 041	Y-916J	6
0 250 201 042	Y-924J	1
0 250 201 043	Y-913J	15
0 250 201 049	Y-937J	5
0 250 201 050	Y-933J	25
0 250 201 053	Y-939J	43
0 250 201 054	Y-925J	16
0 250 201 055	Y-916J	6
0 250 201 405	Y-924J	1
0 250 201 415	Y-918J	2
0 250 202 001	Y-910J	3
0 250 202 002	Y-739R	
0 250 202 003	Y-115T1	
0 250 202 004	Y-128T	
0 250 202 005	Y-117RS	
0 250 202 006	Y-118T1	
0 250 202 007	Y-107R	
0 250 202 008	Y-306R	
0 250 202 009	Y-732J	4
0 250 202 013	Y-204RS	
0 250 202 015	Y-103	
0 250 202 017	Y-112R1	
0 250 202 018	Y-910J	3
0 250 202 020	Y-503J	10
0 250 202 022	Y-732J	4
0 250 202 023	Y-741U	20
0 250 202 024	Y-927J	19
0 250 202 025	Y-730U	17
0 250 202 026	Y-929U	41

BOSCH	→ NGK	D-Power
0 250 202 027	Y-604J	
0 250 202 028	Y-747U	26
0 250 202 029	Y-745U	11
0 250 202 032	Y-504J	24
0 250 202 033	Y-910J	3
0 250 202 034	Y-928U	29
0 250 202 035	Y-506J	7
0 250 202 036	Y-534J	36
0 250 202 038	Y1031J	71
0 250 202 039	Y-745U	11
0 250 202 040	Y-729U	34
0 250 202 041	Y-746J	38
0 250 202 042	Y-748U	14
0 250 202 043	Y-523J	37
0 250 202 045	Y-745U	11
0 250 202 046	Y-741U	20
0 250 202 048	Y1005J	56
0 250 202 051	Y-146R	
0 250 202 054	Y-118R	
0 250 202 058	Y-147T	
0 250 202 064	Y-755RS	
0 250 202 065	Y-904M1	
0 250 202 069	Y-162R1	
0 250 202 071	Y-181T	
0 250 202 076	Y-197R	
0 250 202 077	Y-705RS	
0 250 202 085	Y-710J	
0 250 202 087	Y-711J	28
0 250 202 089	Y-701J	39
0 250 202 090	Y1006J	
0 250 202 092	Y-733J	13
0 250 202 093	Y-712RS	
0 250 202 094	Y-115T1	
0 250 202 095	Y-532J	
0 250 202 096	Y-118T1	
0 250 202 097	Y-197T	
0 250 202 102	Y-501U	31
0 250 202 103	Y-507J	32
0 250 202 107	Y-157R	
0 250 202 119	Y-178T	
0 250 202 124	Y1007J	59
0 250 202 125	Y-531J	44
0 250 202 128	Y-517J	66
0 250 202 129	Y-516J	12
0 250 202 130	Y-548J	75
0 250 202 131	Y-524J	27
0 250 202 132	Y1030J	70
0 250 202 135	Y1005J	56
0 250 202 137	Y-541J	42
0 250 202 140	Y-929U	41
0 250 202 141	Y-745U	11
0 250 202 142	Y-745U	11



BOSCH	→ NGK	D-Power
0 250 202 143	Y-605J	
0 250 203 001	YE07	
0 250 203 002	Y8003J	62
0 250 203 004	YE12	
0 250 203 009	Y8005J	64
0 250 203 012	YE08	
0 250 203 018	Y1045AS	89
0 250 204 001	YE04	40
0 250 204 002	YE05	73
0 250 212 006	Y-749J	
0 250 212 009	Y-732J	4
0 250 212 011	Y-527J	67
0 250 213 007	Y-536J	81
0 250 312 001	CZ259	
0 250 312 002	CZ260	
0 250 312 003	Y-603J	60
0 250 312 007	CZ257	83
0 250 402 001	Y-607AS	50
0 250 402 002	Y-547AS	47
0 250 402 005	Y-607AS	50
0 250 403 001	Y8008AS	74
0 250 403 002	YE14	48
0 250 403 004	Y8011AS	
0 250 403 007	Y1002AS	57
0 250 403 008	Y8002AS	51
0 250 403 009	Y1002AS	57
0 250 403 010	Y8009AS	
0 250 403 011	Y9003AS	78
0 250 403 012	Y1035AS	77
0 250 403 013	Y1036AS	
0 250 403 014	Y9001AS	72
0 250 403 019	Y8010AS	
0 250 403 021	Y1010AS	88
0 250 403 022	Y1047AS	
0 250 404 001	Y8001AS	58
0 250 404 004	Y9001AS	72
0 250 503 003	CZ274	
0 250 523 002	CZ271	
0 250 603 001	CZ167	91
F 01G 000 00P	Y1012J	65
F 01G 004 02X	CZ274	
F 01G 004 031	CZ267	90
GLP 001	Y-924J	1
GLP 002	Y-918J	2
GLP 003	Y-732J	4
GLP 004	Y-503J	10
GLP 005	Y-924J	1
GLP 006	Y-916J	6
GLP 007	Y-534J	36
GLP 008	Y-745U	11
GLP 009	Y-506J	7
GLP 010	Y-910J	3

BOSCH	→ NGK	D-Power
GLP 011	Y-516J	12
GLP 012	Y-937J	5
GLP 013	Y-504J	24
GLP 014	Y-730U	17
GLP 015	Y-924J	1
GLP 016	Y8003J	62
GLP 017	Y-925J	16
GLP 019	Y-748U	14
GLP 020	Y-927J	19
GLP 021	Y-929U	41
GLP 022	Y-745U	11
GLP 023	Y-741U	20
GLP 024	Y-524J	27
GLP 025	Y-930U	30
GLP 026	Y-928U	29
GLP 030	Y-523J	37
GLP 031	Y-501U	31
GLP 032	Y-747U	26
GLP 033	Y-741U	20
GLP 034	Y-115T1	
GLP 035	Y-603J	60
GLP 036	Y-933J	25
GLP 037	Y-913J	15
GLP 038	Y-701J	39
GLP 039	CZ257	83
GLP 040	Y-507J	32
GLP 041	Y-739R	
GLP 042	Y-118T1	
GLP 043	YE07	
GLP 045	Y-939J	43
GLP 046	Y-711J	28
GLP 047	Y-909R	
GLP 048	Y-729U	34
GLP 049	Y-712RS	
GLP 050	Y-607AS	50
GLP 051	Y-548J	75
GLP 054	Y-733J	13
GLP 055	Y1005J	56
GLP 057	Y-517J	66
GLP 059	YE04	40
GLP 063	Y-810	
GLP 066	Y1030J	70
GLP 070	Y-547AS	47
GLP 072	Y-710J	
GLP 074	Y-532J	
GLP 078	Y-604J	
GLP 092	Y-541J	42
GLP 093	YE14	48
GLP 094	YE05	73
GLP 096	Y-306R	
GLP 098	Y-755RS	
GLP 101	Y-531J	44

BOSCH	→ NGK	D-Power
GLP 102	Y-746J	38
GLP 103	Y-904M1	
GLP 105	CZ260	
GLP 108	CZ259	
GLP 109	Y1031J	71
GLP 111	Y1005J	56
GLP 115	YE12	
GLP 116	Y-118R	
GLP 117	Y-107R	
GLP 121	Y-910J	3
GLP 124	Y-146R	
GLP 125	Y-103	
GLP 127	Y-705RS	
GLP 132	Y-197T	
GLP 136	Y-197R	
GLP 137	Y1007J	59
GLP 138	Y-162R1	
GLP 142	Y-147T	
GLP 144	Y8008AS	74
GLP 148	Y-112R1	
GLP 152	Y-178T	
GLP 154	CZ167	91
GLP 156	Y1006J	
GLP 159	Y-128T	
GLP 167	Y-117RS	
GLP 169	Y-157R	
GLP 179	Y8009AS	
GLP 185	Y-181T	
GLP 186	Y-907R	
GLP 194	Y1002AS	57
GLP 196	Y9003AS	78
GLP 201	Y8011AS	
GLP 202	Y8002AS	51
GLP 203	Y-749J	
GLP 205	Y8005J	64
GLP 210	YE08	
GLP 212	Y1012J	65
GLP 221	Y1035AS	77
GLP 222	Y1036AS	
GLP 224	Y-732J	4
GLP 225	Y-605J	
GLP 237	Y1010AS	88
GLP 251	CZ267	90
GLP 253	Y8010AS	
GLP 259	Y1047AS	
GLP 147	CZ274	
GLP 242	CZ271	
GLP 249	CZ274	
GLP 270	Y9001AS	72
GSA 101	Y-810	
GSA 91	Y-810	

BRISK	→ NGK	D-Power
21 N 21	Y-208T	
21 N 22	Y-208T	
21 N 51	Y-909R	
21 R 01	Y-918J	2
21 R 02	Y-907R	
21 R 06	Y-918J	2
21 R 21	Y-924J	1
21 R 22	Y-924J	1
21 R 23	Y-924J	1
21 R 26	Y-913J	15
21 R 51	Y-909R	
21 R 71	Y-910J	3
CHAMPION	→ NGK	D-Power
CCGP 007	CZ167	91
CH 60	Y-207T	
CH 63	Y-208T	
CH 65	Y-810	
CH 68	Y-523J	37
CH 69	Y-918J	2
CH 70	Y-909R	
CH 79	Y-907R	
CH 87	Y-208T	
CH 88	Y-924J	1
CH 90	Y-739R	
CH 94	Y-115T1	
CH 95	Y-146R	
CH 96	Y-204RS	
CH 97	Y-107R	
CH 98	Y-117RS	
CH 101	Y-115R1	
CH 102	Y-112M1	
CH 103	Y-118T1	
CH 104	Y-197R	
CH 121	Y-118T1	
CH 137	Y-924J	1
CH 147	Y-910J	3
CH 154	Y-715R	
CH 158	Y-711J	28
CH 159	Y-924J	1
CH 160	Y-918J	2
CH 161	Y-755RS	
CH 162	Y-707RS	
CH 163	Y-924J	1
CH 166	Y-747U	26
CH 167	Y-928U	29
CH 169	Y-730U	17
CH 170	Y-504J	24
CH 171	Y-732J	4
CH 172	Y-740U	22
CH 173	Y-913J	15
CH 174	Y-924J	1
CH 175	Y-930U	30



CHAMPION	→ NGK	D-Power
CH 176	Y-916J	6
CH 177	Y-925J	16
CH 178	Y-729U	34
CH 179	Y-933J	25
CH 181	Y-741U	20
CH 184	Y-732J	4
CH 185	Y-503J	10
CH 189	Y-924J	1
CH 196	Y-524J	27
CH 203	Y-507J	32
CH 204	Y-929U	41
CH 205	Y-937J	5
CH 206	Y-927J	19
CH 207	Y-748U	14
CH 208	Y-738U	
CH 215	Y-501U	31
CH 216	Y-502R	
CH 217	Y-506J	7
CH 218	Y-745U	11
CH 219	Y-746J	38
CH 221	Y-115T1	
CH 223	Y8003J	62
CH 224	YE07	
CH 263	Y1007J	59
CH 268	Y1005J	56
CH 406	CZ274	
CH 409	CZ24	
CH 600	CZ260	
CH 601	Y-603J	60
CH 602	CZ257	83
CH 722	Y1047AS	
CH 725	Y1045AS	89
CH 7135	Y9001AS	72
DENSO	→ NGK	D-Power
067100-1042	Y-402-2	
067100-1043	Y-452-1	
067100-1070	Y-176	
067100-1071	Y-176	
067100-1120	Y-178	
067100-1130	Y-128	
067100-1161	Y-178T	
067100-1170	Y-128T	
067100-1171	Y-128T	
067100-1270	Y-118T1	
067100-1330	Y-147T	
067100-1340	Y-197T	
067100-1350	Y-128T	
067100-1360	Y-178T	
067100-1370	Y-118R	
067100-1430	Y-146R	
067100-1460	Y-197R	
067100-1530	Y-146R	

DENSO	→ NGK	D-Power
067100-1630	Y-118T1	
067100-1690	Y-703R	
067100-1710	Y-715R	
067100-1860	Y-532J	
DG-001	Y-924J	1
DG-003	Y-503J	10
DG-004	Y-910J	3
DG-005	Y-732J	4
DG-006	Y-913J	15
DG-007	Y-937J	5
DG-008	Y-506J	7
DG-009	Y-927J	19
DG-010	Y-916J	6
DG-012	Y-918J	2
DG-101	Y-740U	22
DG-102	Y-928U	29
DG-103	Y-933J	25
DG-105	Y-115T1	
DG-106	Y-925J	16
DG-108	Y-904M1	
DG-109	Y-741U	20
DG-110	Y-929U	41
DG-111	Y-502R	
DG-112	Y-516J	12
DG-113	YE04	40
DG-114	Y-107R	
DG-115	Y-729U	34
DG-116	Y-504J	24
DG-117	Y-925J	16
DG-118	Y-748U	14
DG-119	Y-930U	30
DG-120	Y-707RS	
DG-121	Y-524J	27
DG-122	Y-534J	36
DG-123	Y-907R	
DG-124	Y-710J	
DG-126	Y-517J	66
DG-127	Y-747U	26
DG-129	Y-939J	43
DG-130	Y-548J	75
DG-133	Y-604J	
DG-137	Y-712RS	
DG-140	YE12	
DG-142	Y-523J	37
DG-144	Y-732J	4
DG-145	Y-507J	32
DG-146	Y-701J	39
DG-155	Y-746J	38
DG-157	Y-705RS	
DG-161	Y-924J	1
DG-170	YE07	
DG-171	Y8003J	62

DENSO	→ NGK	D-Power
DG-172	Y-722JS	
DG-173	Y-749J	
DG-176	Y1031J	71
DG-177	Y-607AS	50
DG-178	Y-547AS	47
DG-180	YE05	73
DG-181	Y1005J	56
DG-182	Y-605J	
DG-184	Y-543J	46
DG-185	Y-910J	3
DG-186	Y1038J	
DG-187	Y1007J	59
DG-188	Y-536J	81
DG-189	Y-508J	
DG-190	YE14	48
DG-193	Y1002AS	57
DG-194	Y8002AS	51
DG-195	Y8005J	64
DG-196	Y1030J	70
DG-197	Y-519J	61
DG-202	Y-909R	
DG-211	Y-715R	
DG-214	Y-532J	
DG-215	Y-118R	
DG-216	Y-703R	
DG-217	Y-531J	44
DG-221	Y-118T1	
DG-222	Y-197R	
DG-223	Y-146R	
DG-226	Y-178	
DG-227	Y-128	
DG-232	Y-147T	
DG-233	Y-197T	
DG-234	Y-128T	
DG-235	Y-178T	
DG-240	Y-542J	45
DG-245	Y-531J	44
DG-300	Y-603J	60
DG-301	CZ257	83
DG-304	CZ260	
DG-305	Y1013J	63
DG-306	CZ256	
DG-307	CZ259	
DG-312	CZ24	
DG-502	Y-529J	
DG-601	CZ274	
DG 611	Y1045AS	89
DG-615	Y-606J	
DG-631	Y1047AS	
DG-633	Y8011AS	
DG-646	CZ24	
DG-658	Y9001AS	72

DENSO	→ NGK	D-Power
DG 662	CZ271	
EYQUEM	→ NGK	D-Power
0 911 101 252	Y1047AS	
HIDRIA	→ NGK	D-Power
11 721 735	Y-506J	7
H0 605	Y-208T	
H0 611	Y-810	
H0 643	Y-306R	
H1 002	Y-924J	1
H1 004	Y-924J	1
H1 005	Y-909R	
H1 006	Y-907R	
H1 052	Y-910J	3
H1 078	Y-916J	6
H1 086	Y-924J	1
H1 087	Y-925J	16
H1 088	Y-930U	30
H1 089	Y-740U	22
H1 090	Y-748U	14
H1 096	Y-937J	5
H1 105	Y-508J	
H1 112	Y-523J	37
H1 117	Y-926U	
H1 118	Y-547AS	47
H1 119	Y-507J	32
H1 120	Y-605J	
H1 121	Y-741U	20
H1 122	Y8002AS	51
H1 123	YE13	
H1 124	Y-536J	81
H1 125	Y-904M1	
H1 126	Y-910J	3
H1 127	Y-607AS	50
H1 143	Y-746J	38
H1 159	Y-927J	19
H1 166	YE05	73
H1 192	CZ24	
H1 193	YE08	
H1 204	Y-530J	
H1 205	Y-755RS	
H1 207	Y1031J	71
H1 208	Y-527J	67
H1 209	CZ259	
H1 211	CZ257	83
H1 212	Y-519J	61
H1 213	Y-197R	
H1 214	Y-757RS	
H1 215	Y-529J	
H1 339	Y1002AS	57
H1 368	Y8001AS	58
H1 392	Y1035AS	77
H1 393	Y1036AS	



HIDRIA	→ NGK	D-Power
H1 394	Y9004AS	
H1 396	Y9003AS	78
H1 408	Y8011AS	
H1 411	Y-606J	
H1 412	CZ256	
H1 418	Y1007J	59
H1 430	Y1012J	65
H1 432	Y-522J	
H1 436	Y-535J	
H1 442	CZ203	68
H1 444	CZ267	90
H1 453	Y1003AS	
H1 469	Y1001J1	
H1 512	Y-146R	
H1 532	Y-107R	
H1 547	Y-115T1	
H1 561	Y-112M1	
H1 568	Y-112R1	
H1 577	Y-162R1	
H1 594	Y-128T	
H1 638	Y-910J	3
H1 656	Y-924J	1
H1 657	Y-207T	
H1 658	Y-543J	46
H1 659	Y-732J	4
H1 665	Y-910J	3
H1 666	Y-722JS	
H1 691	Y-719RS1	
H1 692	Y-710J	
H1 693	Y-738U	
H1 703	Y-115R1	
H1 705	Y-548J	75
H1 709	Y-506J	7
H1 712	Y-928U	29
H1 731	Y-503J	10
H1 732	Y-504J	24
H1 737	YE04	40
H1 738	Y-929U	41
H1 739	Y-745U	11
H1 789	Y-701J	39
H1 790	Y-147T	
H1 792	Y-924J	1
H1 793	Y-747U	26
H1 794	Y-524J	27
H1 795	Y-729U	34
H1 796	Y-157R	
H1 797	Y-712RS	
H1 798	Y-117RS	
H1 799	Y-707RS	
H1 801	Y-705RS	
H1 802	Y-534J	36
H1 807	Y-904M1	

HIDRIA	→ NGK	D-Power
H1 808	Y-502R	
H1 810	Y-741U	20
H1 815	Y8005J	64
H1 816	YE07	
H1 821	Y-739R	
H1 825	Y-732J	4
H1 826	Y-924J	1
H1 842	Y-939J	43
H1 859	Y8003J	62
H1 860	Y-541J	42
H1 918	Y1038J	
H1 919	Y-703R	
H1 920	Y-603J	60
H1 922	Y-516J	12
H1 944	YE12	
H1 955	Y-749J	
H1 961	Y-501U	31
H1 977	Y-517J	66
H1 984	Y-933J	25
H1 992	Y1005J	56
H1 993	YE14	48
H5 015	Y1045AS	89
H5 017	Y1010AS	88
H5 018	Y8008AS	74
H5 020	Y1030J	70
H5 021	CZ274	
H5 025	Y9001AS	72
H5 093	Y1039AS	80
H5 099	Y-181T	
H5 101	Y-271-2	
H5 114	Y-503J	10
H5 122	CZ304	55
H5 123	CZ105	
H5 124	CZ303	54
H5 126	CZ167	91
H5 128	CZ163	82
H5 158	Y9001AS	72
H5 185	CZ158	
H5 191	Y8009AS	
H5 199	CZ104	52
H5 209	CZ106	53
H5 221	CZ551	85
H5 222	CZ159	84
H5 232	Y-537AS	
H5 240	Y8010AS	
H5 247	CZ251	76
H5 248	Y-526J1	69
HKT	→ NGK	D-Power
CP 01	CZ259	
CP 02	CZ260	
CP 22	Y1013J	63
PD 190	Y-146R	



HKT	→ NGK	D-Power
PD 191	Y-703R	
PH 20	Y-173	
PH 21	Y-176	
PI 40	Y-874-1	
PI 42	Y-104	
PI 44	Y-271-2	
PI 49	Y-904M1	
PI 58	Y-710J	
PM 61	Y-175-2	
PM 62	Y-102	
PM 73	Y-274	
PM 75	Y-115T1	
PM 78	Y-971M	
PN 81	Y-103	
PN 86	Y-103-2	
PM 161	Y-115R1	
PN 120	Y-181T	
PN 121	Y-204RS	
PN 123	Y-112M1	
PN 124	Y-162R1	
PN 125	Y-272R1	
PN 126	Y-117RS	
PN 128	Y-112R1	
PN 131	Y-755RS	
PN 132	Y-705RS	
PN 135	Y-707RS	
PN 136	Y-757RS	
PN 137	Y-955RS	
PN 138	Y-712RS	
PS 210	Y-702U	
PT 90	Y-402-2	
PT 93	Y-128	
PT 94	Y-178	
PT 100	Y-128T	
PT 101	Y-178T	
PT 103	Y-118T1	
PT 104	Y-128T	
PT 107	Y-146R	
PT 108	Y-197T	
PT 109	Y-178T	
PT 140	Y-118R	
PT 141	Y-197R	
PT 144	Y-118T1	
PT 145	Y-147T	
PT 147	Y-146R	
PT 150	Y-703R	
PT 151	Y-715R	
PT 157	Y-531J	44
PZ 30	Y-107T	
PZ 31	Y-157R	
PZ 33	Y-107R	
PZ 39	Y-701J	39

MAGNETI MARELLI	→ NGK	D-Power
061 830 024 304	Y-918J	2
061 830 025 304	Y-924J	1
061 830 078 304	Y-924J	1
062 900 119 304	Y1047AS	
TIX 1 A	Y-207T	
TIX 2 A	Y-208T	
TIX 4 A	Y-208T	
TIX 6 A	Y-208T	
UX 1 A	Y-918J	2
UX 2 A	Y-924J	1
UX 4 A	Y-924J	1
UY 42 A	Y1047AS	
MOTORCRAFT	→ NGK	D-Power
10 56 857	Y-937J	5
10 79 401	Y-524J	27
10 96 527	Y-548J	75
16 90 048	Y-741U	20
32 52 725	Y-107R	
50 23 372	Y-208T	
50 31 006	Y-924J	1
61 32 246	Y-907R	
61 54 593	Y-924J	1
70 88 988	Y-910J	3
84BB6-M090-AA	Y-924J	1
84FF6-M090-B2A	Y-907R	
93FF6-M090-AA	Y-910J	3
96FF6-M090-CA	Y-937J	5
EZD 1	Y-810	
EZD 5	Y-924J	1
EZD 10	Y-918J	2
EZD 18	Y-115T1	
EZD 19	Y-128T	
EZD 20	Y-117RS	
EZD 21	Y-118T1	
EZD 22	Y-107T	
EZD 30	Y-924J	1
EZD 40	YE04	40
EZD 41	Y-504J	24
V94DX-6M090-AA	Y-924J	1
V95DD-6M090-AA	Y-741U	20
XS4U-6M090-AB	Y-524J	27
XS7U-6M090-BA	Y-548J	75







DISCONTINUED PRODUCTS

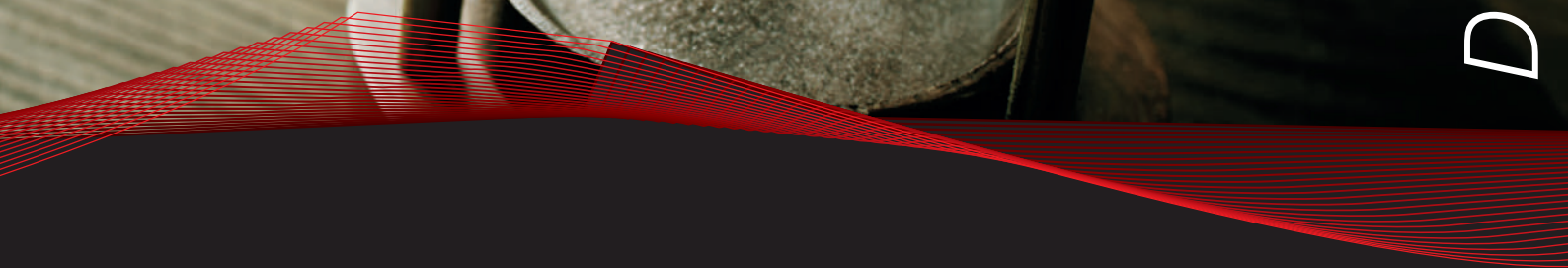

IGNITION
PARTS



A-6	AB-6
A-7	AB-7
A-8	AB-8
A-8F	A8FS
A-9F	A9FS
APR5FS-11	APR5FS
B105EGV	BR10EIX
B10ECS	BR10ECS
B10EGP	R7376-10
B10EGV	BR10EIX
B10EV	BR10EIX
B10EVX	BR10EIX
B10H	B10HS
B10HN	BR10HIX
B10HP	BR10HIX
B10HV	BR10HIX
B10HVX	BR10HIX
B11EGV	BR10EIX
B11EN	BR10EIX
B11HN	BR10HIX
B11HP	BR10HIX
B5ES-11	B5ES
B6EB-L-11	BR6ES
B6EFS	BR6EF
B6FS	BR6FS
B6HV	BR6HIX
B6HVX	BR6HIX
B7EB	BR7ES
B7EB-11	BUR7EB-11
B7ET	BR7ET
B7EV	BR7EIX
B7EVX	BR7EIX
B7HV	BR7HIX
B7HVX	BR7HIX
B85EGV	BR9EIX
B8EGP	BR8EIX
B8EGV	BR8EIX
B8EMV	BR8ET
B8EN	BR8EIX
B8ES-11	B8ES
B8ET	BR8ET
B8EV	BR8EIX
B8EVX	BR8EIX
B8HN	BR8HIX
B8HV	BR8HIX
B8HVX	BR8HIX
B95EGV	BR10EIX
B9EGP	BR9EIX
B9EGV	BR9EIX
B9EN	BR9EIX
B9EV	BR9EIX
B9EVX	BR9EIX
B9HCV	BR9HIX



B9HN	BR9HIX
B9HP	BR9HIX
B9HV	BR9HIX
B9HVX	BR9HIX
BCP4ES	BCPR4ES-11
BCP4ES-11	BCPR4ES-11
BCP5E-11	BCPR5E-11
BCP5ET	BCPR5ET
BCP5EV	BCPR5EIX
BCP5EV-11	BCPR5EIX-11
BCP5EVX	BCPR5EIX
BCP5EVX-11	BCPR5EIX-11
BCP5EY-11	BCPR5EY-11
BCP6E-11	BKR6E-11
BCP6EV-11	BCPR6EIX-11
BCP6EVX-11	BCPR6EIX-11
BCP7E	BCPR7E
BCP7E-11	BCPR7E-11
BCP7ES-11	BKR7E-11
BCP7EV	BCPR7EIX
BCP7EVX	BCPR7EIX
BCPR5EP-11	BCPR5EIX-11
BCPR5EP-13	BCPR5EIX-11
BCPR5EVX-11	BCPR5EIX-11
BCPR6EP-13	BCPR6EIX-11
BCPR6EP-N-11	BCPR6EIX-11
BCPR6ER	BKR6EK
BCPR6EVX-11	BCPR6EIX-11
BCPR7ER	BKR6EK
BCPR7EVX-11	BKR7EIX-11
BCPR7EY	BCPR7E
BK5EKU	BKR5EKU
BK7E-11	BKR7E-11
BK7EKU	BKR7EKU
BKR5EVX	BKR5EIX
BKR5EVX-11	BKR5EIX-11
BKR5EVXA-13	PFR5G-13E
BKR6EIX-LPG	LPG1
BKR6EVX	BKR6EIX
BKR6EVX-11	BKR6EIX-11
BKR6EVXA-11	PFR6G-13E
BKR6EVXA-13	PFR6G-13E
BKR7EVX	BKR7EIX
BKR7EVX-11	BKR7EIX-11
BP10EV	BPR10EIX
BP4EFS	TR4IX
BP4ES-13	BPR4ES-13
BP4HSA	BPR4HSA
BP5EA	BP4EY
BP5EA-11	BP4EY-11
BP5EA-L	BP5EY
BP5EA-L-11	BP5EY-11
BP5EJ	BPR5EJ





BP5EKN	BPR5EY
BP5EV	BPR5EIX
BP5EVX	BPR5EIX
BP5EVX-11	BPR5EIX-11
BP5HA	BP5HS
BP6EA	BP6EY
BP6EA-11	BP6EY-11
BP6EF-13	BPR6EF-13
BP6EK	BPR6EK-A
BP6EK-A	BPR6EK-A
BP6EKA-V	BPR6EK-A
BP6EKN	BPR6EKN
BP6ES-13	BPR6EIX-11
BP6EV	BPR6EIX
BP6EVX	BPR6EIX
BP6EVX-11	BPR6EIX-11
BP6HV	BPR6HIX
BP6HVX	BPR6HIX
BP7E	BPR7E
BP7EFVX	TR7IX
BP7EKN	BPR7EKN
BP7EV	BPR7EIX
BP7EVX	BPR7EIX
BP7EY-11	BPR7EY-11
BP7HV	BPR7HIX
BP7HVX	BPR7HIX
BP8ES-11	BP8ES
BP8EV	BPR8EIX
BP8EVX	BPR8EIX
BP8FS	R5674-8
BP8HSA	BPR8HSA
BP8HVX	BPR8HIX
BP9EV	BPR9EIX
BPR-2E	BPR2ES
BPR4EVX	GR4IX
BPR4S	BP-4
BPR4S-15	BP-4
BPR5EA	BPR5EY
BPR5EA-11	BPR5EY-11
BPR5EA-L	BPR5EY
BPR5EA-L-11	BPR5EY-11
BPR5EF-13	BPR5EFS-13
BPR5EFVX	TR5IX
BPR5EK-A	BPR5EIX-11
BPR5EP-13	BPR5EP-11
BPR5EV	BPR5EIX
BPR5EVX	BPR5EIX
BPR5EVX-11	BPR5EIX-11
BPR5S	BP5S
BPR6EA	BPR5EY
BPR6EIX-LPG	LPG2
BPR6ES-13	BPR6EIX-11
BPR6EV	BPR6EIX

BPR6EVX	BPR6EIX
BPR6EVX-11	BPR6EIX-11
BPR6FS-15	BPR6FS
BPR6HVX	BPR6HIX
BPR6S	BP6S
BPR7EVX	BPR7EIX
BPR7EY	BPR7EIX
BPR7HVX	BPR7HIX
BPR8EVX	BPR8EIX
BPR9EVX	BPR9EIX
BR10ECMVX	BR10ECMIX
BR10EV	BR10EIX
BR10EVX	BR10EIX
BR5EB	BR5ES
BR5EB-11	BUR5EB-11
BR5ES-11	BR5ES
BR5FS-15	BR5FS
BR6EB	BR6ES
BR6EB-11	BUR6EB-11
BR6FS-15	BR6FS
BR7EB	BR7ES
BR7EB-11	BUR7EB-11
BR7EM	B7EM
BR7ES-11	BR7ES
BR7EVX	BR7EIX
BR8ECMVX	BR8ECMIX
BR8EV	BR8EIX
BR8EVX	BR8EIX
BR8HV	BR8HIX
BR8HVX	BR8HIX
BR9ECMVX	BR9ECMIX
BR9EV	BR9EIX
BR9EVX	BR9EIX
BRE813L	BR8ET
BU6EA-11	BUR6EA-11
BU6EB-11	BUR6EB-11
BU7EA-11	BUR7EA-11
BUEW	BUE
BUR5EBVX-11	BUR5EB-11
BZ8ES	BR8ES
C10H	R0161-10
C4HA	CR4HSA
C6H	C6HSA
C6M	C6HSA
C7EH-9	CR7EH-9
C7HV	CR7HIX
C7HVX	CR7HIX
C8EHVX-9	CR8EHIX-9
C8EVX	CR8EIX
C8HV	CR8HIX
C8HVX	CR8HIX
C9EHVX-9	CR9EHIX-9
C9EVX	CR9EIX





C9H	C8HSA
CR8EHVX-9	CR8EHIX-9
CR8EVX	CR8EIX
CR8HVX	CR8HIX
CR9EHVX-9	CR9EHIX-9
CR9EVX	CR9EIX
D12E	R2349-11
D-4H	DR4HS
D6ES	D6EA
D6HS	D6HA
D6HV	D6HA
D7EV	DR7EIX
D7EVX	DR7EIX
D8EV	DR8EIX
D8EVX	DR8EIX
D8HS	D8HA
D8HV	D8HA
D9EV	DR9EIX
D9EVX	DR9EIX
DCP7EVX	DCPR7EIX
DCP8E	DCPR8E
DCP8EVX	DCPR8EIX
DCPR7E-N	DCPR7E-N-10
DCPR7EVX	DCPR7EIX
DCPR8EVX	DCPR8EIX
DCPR9EVX	DCPR9EIX
DIMR8A10	DIMR8C10
DIMR8B10	DIMR8C10
DP5EA-9	DPR5EA-9
DP7Z	DPR7Z
DP8EV-9	DPR8EIX-9
DP8EVX-9	DPR8EIX-9
DP9EV-9	DPR9EIX-9
DP9EVX-9	DPR9EIX-9
DP9Z	DPR9Z
DPR7EV-9	DPR7EIX-9
DPR7EVX-9	DPR7EIX-9
DPR8EV-9	DPR8EIX-9
DPR8EVX-9	DPR8EIX-9
DPR9EV-9	DPR9EIX-9
DPR9EVX-9	DPR9EIX-9
DR8EVX	DR8EIX
DR9EVX	DR9EIX
FR2A-D	FR2B-D
GR4VX	GR4
GR5VX	GR5IX
IFR7G-11K	IFR7G-11KS
IKR9F8	IKR9J8
ILKAR6C10	ILKAR7C10
ILZKBR7A-8G	ILZKBR7B8G
ILZKBR7B8DG	ILZKBR7B8G
ITR5F13	TR5AI-13
J10A	JR10B

JR10A	JR10B
JR9A	JR9B
LKR9CI-8	ILKR9G8
PFR4B-11	PFR4G-11
PFR4C-11	PFR4G-11
PFR5B	PFR5B-9
PFR6C-11	PFR6G-11
PFR6K-11	PFR6A-11
PGR6B	PGR6A-11
PLZKBR7A-G	PLZKBR7B8G
PTR4B-15	ITR4A15
PZFR6B	IZFR6B
PZFR6R8EG	SIZFR6B8EG
PZKER7A8EGS	PZKER7B8EGS
R0045A-10	R0045Q-10
R0045A-11	R0045Q-11
R0045G-10	R0045Q-10
R0045G-11	R0045Q-11
R0045J-10	R0045Q-10
R0045J-11	R0045Q-11
R0045J-9	R0045Q-9
R015-10	R0373A-10
R015-8	CR8EIX
R015-9	R0373A-10
R015-95	R0373A-10
R016-10	R0373A-10
R016-105	R0373A-9
R016-11	R0373A-11
R0161-9	CR9HIX
R016-8	CR8EIX
R016-9	R0373A-10
R016E-11P	R0373A-11
R017-10	R0373A-10
R017-11	R0373A-11
R017-8	R0373A-8
R017-9	R0373A-9
R017-S11	R0373A-11
R0256K-11	R0373A-11
R0256R-10	R0373A-10
R2097-11P	R2525-10
R216-10	R2525-10
R216-11	R2525-10
R216-12	R2349-11
R216-9	R2525-9
R217-10	R2525-10
R217-11	R2525-10
R217-12	R2349-11
R217-9	R2525-9
R2198-12P	R2349-11
R2270-11	R2349-11
R2270-9	R2349-9
R2430-10	R2349-10
R2430-9	R2349-9





R2525-11	R2349-11
R2556B-10	R2556G-10
R2556B-8	R2556G-8
R2556B-9	R2556G-9
R2558A-10	R2558E-10
R2558A-8	R2558E-8
R2558A-9	R2558E-9
R4118M-10	BR10EIX
R4118-M8	BR8EIX
R4118-M9	BR9EIX
R4118S-10	BR10EIX
R4118S-7	R7376-7
R4118S-8	BR8EIX
R4118S-9	BR9EIX
R4304A-10	BPR10EIX
R4304A-7	BPR7EIX
R4304A-8	BPR8EIX
R4304A-9	BPR9EIX
R4339-9	B9EG
R4452D-10	R7376-10
R4452D-8	BR8EIX
R4452D-85	B85EGP
R4452D-9	BR9EIX
R4468A-11	R6725-11
R4468A-115	R6725-115
R4630A-10	R7376-10
R4630A-105	R7376-10
R4630A-11	R7376-10
R4630A-8	R7376-8
R4630A-9	R7376-9
R5184-10	BR10ECMIX
R5184-105	R7282-105
R5184-11	R7282-11
R5300A-10	R7282-10
R5300A-105	R7282-105
R5300A-11	R7282-11
R5300A-9	R7282-9
R5300N-105	R7282-105
R5400-10	R7435-10
R5400-7	BCPR7EIX
R5400-8	R7435-8
R5400-9	R7435-9
R5525-10	BR10HIX
R5525-11	BR10HIX
R5525-7	BR7HIX
R5525-8	BR8HIX
R5525-9	BR9HIX
R5530-10	BR10HIX
R5530-11	BR10HIX
R5530-8	BR8HIX
R5530-9	BR9HIX
R5540F-105	R7282-105
R5540F-11	R7282-11

R5649-10	R6712-10
R5649-11	R6712-10
R5649-9	R6712-9
R5671-8	R5671A-8
R5671-9	R5671A-9
R5672-8	R5672A-8
R5672-9	R5672A-9
R5686-10	R7436-10
R5686-11	R7436-10
R5686-8	R7436-8
R5686-9	R7436-9
R5687-10	R7436-10
R5687-8	R7436-8
R5687-9	R7436-9
R5796-8	R7436-8
R5830-10	R7436-10
R5830-9	R7436-9
R5883-10	R6690-10
R5883-11	R6690-11
R5883-9	R6690-9
R6021E-10	BR10EIX
R6021E-85	R6918B-9
R6021E-9	R6918B-9
R6061-8	BR8ECMIX
R6120-10	R7282-10
R6120-105	R7282-105
R6120-11	R7282-11
R6120A-105	R7282A-105
R6120A-11	R7282A-11
R6120C-105	R7282-105
R6120C-11	R7282-11
R6120M-105	R7282-105
R6179A-105P	R7282-105
R6205-9	R7433-9
R6242-10	R7434-10
R6252E-8	R7376-8
R6252E-9	R7376-9
R6254E-8	R6254E-9
R6255-9	R7433-9
R6326-9	R7433-9
R6385-105P	R7376-10
R6385-10P	R7376-10
R6385-11P	R7376-10
R6385-8P	R7376-8
R6385-9P	R7376-9
R6711-10	R6601-9
R6711-9	R6601-9
R6888A-8	R7433-8
R6888A-9	R7433-9
R7112-7	IRIWAY7
R7112-8	R7433-8
R7112-9	R7433-9
R7113-8	R7433-8





R7113-9	R7433-9
R7114-9	R7433-9
R7115-10	R7433-10
R7115-8	R7433-8
R7115-9	R7433-9
R7116-10	R7434-10
R7116-8	R7434-8
R7116-9	R7434-9
R7117-10	R7434-10
R7117-8	R7434-8
R7117-9	R7434-9
R7118-10	R7434-10
R7118-8	R7434-8
R7118-9	R7434-9
R7119-10	R7434-10
R7119-8	R7434-8
R7119-9	R7434-9
R7232-10	R7435-10
R7232-7	BCPR7EIX
R7232-8	R7435-8
R7232-9	R7435-9
R7233-10	R7435-10
R7233-7	R7435-8
R7234-10	R7436-10
R7234-8	R7436-8
R7234-9	R7436-9
R7235-10	R7435-10
R7235-8	R7435-8
R7235-9	R7435-9
R7236-10	R7436-10
R7236-8	R7436-8
R7236-9	R7436-9
R7238-10	R7436-10
R7238-8	R7436-8
R7238-9	R7436-9
R7239-10	R7436-10
R7239-9	R7436-9
R7279-10	R7434-10
R7279-9	R7434-9
R7282C-105	R7282-105
R7282C-11	R7282-11
R7282M-105	R7282-105
R7282M-115	R7282-11
RE8A-L	RE8C-L
SD10A	BUR7EQ
SD11A	BUR9EQ
SR5	TR5-1
TR4-2	TR4
TR4VX	TR4IX
TR5-1VX	TR5-1IX
TR55-1VX	TR55-1IX
TR55GP	TR55IX
TR55VX	TR55IX

UR40	UR45
UR45VX	UR45IX
UR4VX	UR4IX
UR55VX	UR55IX
UR5VX	UR5IX
UR6VX	UR6IX
WR5GP	WR5IX
WR5VX	WR5IX
XR40	XR45
XR45VX	XR45IX
XR4VX	XR4IX
XR5VX	XR5IX
YR55VX	YR55IX
YR5VX	YR5IX
ZF6A-11	ZFR6A-11
ZFR5FVX-11	ZFR5FIX-11
ZFR7A-11	ZFR7F-11
ZG5E	BPR5EY





CY03	Y-603J
CY51	CZ259
CY52	CZ260
CY53	Y-603J
CY55	CZ256
CY57	CZ257
CY58	CZ261
CZ51	CZ166
CZ71	CZ258
Y-207TS	Y-207T
Y-503R	Y-503J
Y-504R	Y-504J
Y-506R	Y-506J
Y-507R	Y-507J
Y-515J	Y-732J
Y-525J	Y-548J
Y-701R	Y-701J
Y-722J	Y-722JS
Y-731U	Y-503J
Y-732U	Y-732J
Y-742U	Y-710J
Y-746R	Y-746J
Y-901R	Y-918J
Y-902R	Y-924J
Y-904M	Y-904M1
Y-908R	Y-924J
Y-910R	Y-910J
Y-911J	Y-910J
Y-911R	Y-910J
Y-913M	Y-913J
Y-914U	Y-924J
Y-924U	Y-924J
Y-933R	Y-933J
Y-937R	Y-937J



Disclaimer

EN

This catalogue supersedes all previous catalogues. NGK SPARK PLUG EUROPE GmbH has made its best effort to ensure an accurate information, based on information available at the time of the compilation of the catalogue.

This catalogue is made for information only. NGK SPARK PLUG EUROPE GmbH will not accept liability for any inaccuracy. Product linkage to vehicles or tools applications from this publication are considered under normal condition of use, fitted by a professional and for vehicles registered in Europe. For all different usage or post equipment, the responsibility of NGK SPARK PLUG EUROPE GmbH cannot be engaged. All ordered products are subject to valid terms and conditions supplied by NGK SPARK PLUG EUROPE GmbH.

The cross reference list (page 591-690) is furnished as a guide. Due to differences in design, materials, etc., products by various manufacturers may not match. See therefore our recommendation for the proper use of the acquired product.

Pictures, diagrams and drawings in this publication are not contractual. The property of the pictures, diagrams, drawings and other graphic elements and data belong to NGK SPARK PLUG EUROPE GmbH exclusively. Reproduction of this publication, partial or total, is strictly prohibited without a prior written authorization of NGK SPARK PLUG EUROPE GmbH.

Specification is subject to change without notice.

DE

Mit Veröffentlichung dieser Ausgabe verlieren alle vorhergehenden Ausgaben ihre Gültigkeit. Dieser Katalog wurde, basierend auf den zum Zeitpunkt der Erstellung des Katalogs verfügbaren Informationen, von der NGK SPARK PLUG EUROPE GmbH nach bestmöglichem Wissen erstellt.

Dieser Katalog dient ausschließlich zu Informationszwecken. Die NGK SPARK PLUG EUROPE GmbH übernimmt keine Haftung für Druckfehler, Irrtümer oder sonstige fehlerhafte Informationen. Alle in diesem Katalog erwähnten Produkt-Zuordnungen zu Fahrzeugen oder Werkzeugen gelten für einen Einsatz unter normalen Bedingungen, den Einbau durch einen Fachmann sowie Fahrzeuge, die innerhalb der EU zugelassen sind. Die NGK SPARK PLUG EUROPE GmbH kann nicht für andere Nutzungszwecke oder Nachrüstungen jedweder Art haftbar gemacht werden. Alle bestellten Produkte unterliegen den geltenden Geschäftsbedingungen der NGK SPARK PLUG EUROPE GmbH.

Die Referenzliste (Seite 591-690) dient nur zur Information. Bedingt durch Unterschiede hinsichtlich Konstruktion, Werkstoffen usw. können Produkte verschiedener Hersteller nicht zusammenpassen. Siehe daher unsere Empfehlung für die richtige Anwendung des erworbenen Produkts.

Die in diesem Katalog abgebildeten Bilder, Diagramme und Zeichnungen sind nicht Vertragsbestandteil. Alle

Bilder, Diagramme, Zeichnungen sowie andere graphische Elemente und Daten sind exklusives Eigentum der NGK SPARK PLUG EUROPE GmbH. Jedwede Vervielfältigung dieses Katalogs, auch auszugsweise, ohne vorherige schriftliche Genehmigung durch die NGK SPARK PLUG EUROPE GmbH ist strengstens untersagt.

Die Spezifikation kann ohne vorherige Ankündigung geändert werden.

FR

NGK SPARK PLUG EUROPE GmbH a réalisé tous les efforts nécessaires pour assurer l'exactitude des informations sur la base des informations disponibles au moment de la compilation du catalogue.

Ce catalogue a été élaboré à titre informatif uniquement. NGK SPARK PLUG EUROPE GmbH n'acceptera aucune responsabilité en cas d'inexactitude. Les liens de produits avec des véhicules ou des outils dans cette publication sont considérés dans des conditions normales d'utilisation, installés par un professionnel et pour les véhicules immatriculés en Europe. Pour toute utilisation différente ou équipement de conversion, la responsabilité de NGK SPARK PLUG EUROPE GmbH ne peut pas être engagée. Tous les produits commandés sont soumis à des termes et conditions valides fournis par NGK SPARK PLUG EUROPE GmbH. Les images, diagrammes et dessins de cette publication ne sont pas contractuels.

Ce tableau de comparaison (page 591-690) est donné à titre indicatif. De par leurs différences de conceptions, matériaux, etc., les pièces produites par les différents fabricants n'ont pas exactement les mêmes caractéristiques. Se reporter au tableau d'affectations NGK SPARK PLUG EUROPE GmbH pour déterminer la référence adaptée à l'application.

Les images, les diagrammes, les dessins et autres éléments graphiques et données appartiennent à NGK SPARK PLUG EUROPE GmbH exclusivement. La reproduction de cette publication, partielle ou totale, est strictement interdite sans autorisation écrite préalable de NGK SPARK PLUG EUROPE GmbH.

Les spécifications peuvent être sujettes à modifications sans avis préalable.

IT

Il presente catalogo sostituisce tutti i precedenti. NGK SPARK PLUG EUROPE GmbH ha posto la massima attenzione per offrire informazioni accurate, basate sui dati disponibili al momento della compilazione del catalogo. Il presente catalogo ha esclusivamente scopo informativo. NGK SPARK PLUG EUROPE GmbH non si assume nessuna responsabilità per eventuali imprecisioni. Si considera che i veicoli a cui si riferisce questa pubblicazione si trovino in condizioni di utilizzo normali, siano stati montati da un professionista e su veicoli immatricolati in Europa. Per qualsiasi utilizzo o per attrezzature montate successivamente, NGK SPARK PLUG EUROPE GmbH non si assume nessuna responsabilità.



Tutti i prodotti ordinati sono soggetti ai termini e alle condizioni forniti da NGK SPARK PLUG EUROPE GmbH. Le tabelle comparative (pag. 591-690) vengono fornite a scopo di guida. A causa della differenza nel design, materiale, ecc., le candele d'accensione prodotte da un altro costruttore potrebbero non corrispondere. Attenersi alle nostre raccomandazioni per il corretto utilizzo del prodotto. Le immagini, i grafici e i disegni presenti in questa pubblicazione non sono contrattuali. Le immagini, dei grafici, i disegni e gli altri elementi e dati sono di proprietà esclusiva di NGK SPARK PLUG EUROPE GmbH. La riproduzione della presente pubblicazione, parziale o totale, è strettamente proibita senza la preventiva autorizzazione scritta di NGK SPARK PLUG EUROPE GmbH. Le specifiche sono soggette a modifiche senza preavviso.

ES

Este catálogo reemplaza a todos los catálogos anteriores. NGK SPARK PLUG EUROPE GmbH ha hecho todo lo posible para garantizar que la información sea correcta, basándose en la información disponible en el momento de la redacción del catálogo.

Este catálogo se ha hecho con propósitos meramente informativos. NGK SPARK PLUG EUROPE GmbH no acepta ninguna responsabilidad por los posibles errores. Se considera que la utilización de los productos en vehículos o aplicaciones de herramientas de esta publicación se realiza en condiciones de uso normales, montados por un profesional y en vehículos matriculados en Europa. Para todos los otros usos o equipamiento a posteriori, NGK SPARK PLUG EUROPE GmbH no puede considerarse responsable. Todos los productos pedidos están sujetos a los términos y condiciones válidos de NGK SPARK PLUG EUROPE GmbH. Las imágenes, los diagramas y los dibujos de esta publicación no tienen valor contractual.

La lista de referencias cruzadas (páginas 591-690) le servirá como guía. Debido a la diferencia en el diseño, materiales, etc., las bobinas producidas por otro fabricante pueden no coincidir. Siga nuestras recomendaciones para el uso adecuado del producto.

Las imágenes, los diagramas, los dibujos, los otros elementos gráficos y los datos son propiedad exclusiva de NGK SPARK PLUG EUROPE GmbH. La reproducción total o parcial de esta publicación está estrictamente prohibida sin una autorización previa por escrito de NGK SPARK PLUG EUROPE GmbH.

Las especificaciones están sujetas a cambios sin previo aviso.

NL

Deze catalogus vervangt alle eerdere catalogi. NGK SPARK PLUG EUROPE GmbH heeft alles in het werk gesteld om voor nauwkeurige informatie te zorgen, op basis van de informatie die voorhanden was op het moment dat de catalogus werd samengesteld.

Deze catalogus dient slechts ter informatie. NGK SPARK PLUG EUROPE GmbH aanvaardt geen aansprakelijkheid voor eventuele onnauwkeurigheden. Producten die in verband

worden gebracht met voertuigen of gereedschaptoepassingen van deze publicatie worden beschouwd onder normale gebruiksomstandigheden, geïnstalleerd door een professional en voor voertuigen die in Europa zijn geregistreerd. Voor alle andere gebruik of retrofitting aanvaardt NGK SPARK PLUG EUROPE GmbH geen aansprakelijkheid. Alle bestelde producten vallen onder de geldige algemene voorwaarden van NGK SPARK PLUG EUROPE GmbH.

De lijst met kruisverwijzingen (pagina 591-690) dient als leidraad. Door verschillen in ontwerp, materialen, enz. kunnen producten die door verschillende fabrikanten zijn vervaardigd afwijken. Zie ook onze aanbeveling voor het juiste gebruik van het product dat u gekocht heeft.

Afbeeldingen, schema's en tekeningen in deze publicatie zijn niet bindend. Afbeeldingen, schema's, tekeningen en andere grafische elementen en gegevens zijn exclusief eigendom van NGK SPARK PLUG EUROPE GmbH. Gedeeltelijke of volledige reproductie van deze publicatie is ten strengste verboden zonder schriftelijke toestemming vooraf van NGK SPARK PLUG EUROPE GmbH.

Specificaties kunnen zonder voorafgaande kennisgeving worden gewijzigd.

PT

Este catálogo substitui todos os catálogos anteriores. NGK SPARK PLUG EUROPE GmbH emvidou os seus melhores esforços para assegurar uma informação precisa, com base nas informações disponíveis no momento da compilação do catálogo. Este catálogo é elaborado apenas para efeitos informativos. NGK SPARK PLUG EUROPE GmbH não aceita qualquer responsabilidade por qualquer imprecisão. A ligação do produto a aplicações de veículos ou ferramentas desta publicação é considerada sob condições normais de uso, montado por um profissional e para veículos matriculados na Europa. Para todos os usos diferentes ou pós-equipamento, a responsabilidade de NGK SPARK PLUG EUROPE GmbH não pode se comprometer. Todos os produtos encomendados estão sujeitos a termos e condições válidos fornecidos pela NGK SPARK PLUG EUROPE GmbH. Esta lista de referência cruzada (página 591-690) é fornecida como guia. Devido a diferenças em termos de design, materiais, etc., os produtos dos vários fabricantes poderão não corresponder. Consequentemente, consulte a nossa recomendação quanto à utilização adequada do produto adquirido. As fotos, diagramas e desenhos nesta publicação não são contratuais. A propriedade das fotos, diagramas, desenhos e outros elementos gráficos e dados pertencem exclusivamente a NGK SPARK PLUG EUROPE GmbH. A reprodução desta publicação, parcial ou integral, é estritamente proibida sem uma autorização prévia por escrito da NGK SPARK PLUG EUROPE GmbH.

As especificações estão sujeitas a alterações sem aviso prévio.



GR

Αυτός ο κατάλογος αντικαθιστά όλους τους προηγούμενους καταλόγους. Η NGK SPARK PLUG EUROPE GmbH έχει κάνει κάθε δυνατή προσπάθεια για να εξασφαλιζόμαστε η ακριβής πληροφόρηση, βάσει των διαθέσιμων πληροφοριών κατά το χρόνο της κατάρτισης του καταλόγου. Αυτός ο κατάλογος έχει στόχο μόνο την πληροφόρηση. Η NGK SPARK PLUG EUROPE GmbH δεν αναλαμβάνει καμία ευθύνη για οποιαδήποτε ανακρίβεια. Η σύνδεση του προϊόντος σε οχήματα ή εφαρμογές εργαλείων του παρόντος καταλόγου θεωρείται ότι γίνονται υπό κανονικές συνθήκες χρήσης, με εγκατάσταση από επαγγελματίες και για τα οχήματα που έχουν ταξινομηθεί στην Ευρώπη. Για όλες τις άλλες περιπτώσεις διαφορετικής χρήσης ή προσθήκης εξοπλισμού, δεν φέρει ευθύνη η NGK SPARK PLUG EUROPE GmbH. Όλα τα παραγγελθέντα προϊόντα υπόκεινται σε έγκυρους όρους και προϋποθέσεις που παρέχονται από την NGK SPARK PLUG EUROPE GmbH.

Αυτή η λίστα παραπομπών (σελ. 591-690) παρέχεται ως οδηγός. Λόγω των διαφορών στη σχεδίαση, στα υλικά κ.λπ., τα προϊόντα από διάφορους κατασκευαστές ενδέχεται να παρουσιάζουν ασυμφωνίες. Συνεπώς, ανατρέξτε στις συστάσεις μας για την ενδεδειγμένη χρήση του προϊόντος που έχετε αποκτήσει.

Εικόνες, διαγράμματα και σχέδια σε αυτήν την έκδοση δεν αποτελούν μέρος σύμβασης. Οι εικόνες, διαγράμματα, σχέδια και άλλα γραφικά στοιχεία και δεδομένα αποτελούν αποκλειστική ιδιοκτησία της NGK SPARK PLUG EUROPE GmbH. Απαγορεύεται αυστηρά η ολική ή μερική αναπαραγωγή της δημοσίευσης χωρίς την προηγούμενη γραπτή άδεια της NGK SPARK PLUG EUROPE GmbH. Η προδιαγραφή μπορεί να αλλάξει χωρίς προειδοποίηση.

TR

Bu katalog önceki tüm katalogların yerini alır. NGK SPARK PLUG EUROPE GmbH, bu katalogun hazırlanma aşamasında mevcut olan bilgilere dayanarak doğru bilgiler vermek için elinden geleni yapmıştır. Bu katalog yalnızca bilgi amaçlı hazırlanmıştır. NGK SPARK PLUG EUROPE GmbH, herhangi bir hata için sorumluluk kabul etmez. Bu yayındaki taşıt ve araç uygulamalarına atıfta bulunan ürün bağlantıları verilirken normal kullanım koşulları, bir uzmanca takılmış olması göz önünde bulundurulmuştur ve Avrupa'da tescillenmiş taşıtlar içindir. Farklı herhangi bir kullanım veya sonradan takılan ekipmanlar için NGK SPARK PLUG EUROPE GmbH sorumlu tutulamaz. Sipariş edilen tüm ürünler, NGK SPARK PLUG EUROPE GmbH tarafından sağlanan geçerli şartlara ve koşullara tabidir. Çapraz referans listesi (sayfa 591-690) bir kılavuz olarak verilmiştir. Not: Bu tablo referans amaçlıdır. Tasarım, malzeme ve benzeri şeylerdeki farklılıklar sebebiyle, farklı üreticilerin ürünleri eşleşmeyebilir. Bu yüzden alınan ürünün uygun kullanımı ile ilgili tavsiyelerimize bakın. Bu yayındaki resimler, şemalar ve çizimler taahhüt değildir. Resimlerin, çizimlerin ve diğer grafik öğelerin mülkiyeti yalnızca NGK SPARK PLUG EUROPE GmbH'ye aittir. Bu yayının NGK SPARK PLUG EUROPE GmbH'den önceden yazılı izin

almadan kısmi veya tam olarak yeniden çoğaltılması kesinlikle yasaktır.

Ürün özellikleri önceden bildirilmeksizin değiştirilebilir.

PL

Niniejszy katalog zastępuje wszystkie poprzednie katalogi. Firma NGK SPARK PLUG EUROPE GmbH dołożyła najlepszych starań, aby upewnić się, że katalog zawiera precyzyjne informacje opierające się na danych dostępnych w czasie opracowania katalogu.

Niniejszy katalog ma charakter wyłącznie informacyjny. Firma NGK SPARK PLUG EUROPE GmbH nie ponosi żadnej odpowiedzialności za jakiegokolwiek nieprecyzyjne dane. Przystosowanie produktów do pojazdów lub narzędzi wymienionych w niniejszej publikacji zakłada normalne warunki stosowania, montaż przez profesjonalistów oraz pojazdy zarejestrowane w Europie. Firma NGK SPARK PLUG EUROPE GmbH nie ponosi żadnej odpowiedzialności za jakiegokolwiek przypadki innych zastosowań lub stosowanie w sprzęcie innego rodzaju. Wszystkie zamówione produkty podlegają odpowiednim warunkom i postanowieniom określonym przez firmę NGK SPARK PLUG EUROPE GmbH.

Załączona lista porównawcza (strony 591-690) powinna być traktowana jedynie jako wskazówka. Ze względu na różnice w kształcie, zastosowanych materiałach itp., produkty poszczególnych producentów mogą się różnić między sobą. Z powyższych powodów prosimy stosować się do zaleceń dotyczących użytkowania produktu. Ilustracje, schematy i rysunki zawarte w niniejszej publikacji nie mają mocy umownej. Ilustracje, schematy, rysunki i inne elementy graficzne oraz dane należą wyłącznie do firmy NGK SPARK PLUG EUROPE GmbH. Reprodukacja niniejszej publikacji w części lub w całości jest surowo zabroniona bez uzyskania wcześniejszego pisemnego upoważnienia ze strony firmy NGK SPARK PLUG EUROPE GmbH.

Specyfikacja może ulec zmianie bez powiadomienia.

CZ

Tento katalog nahrazuje všechny předchozí katalogy. NGK SPARK PLUG EUROPE GmbH vyvinul co největší úsilí, aby poskytl nejpřesnější informace, založených na informacích dostupných v okamžiku sestavení katalogu.

Tento katalog je jen pro informační účely. NGK SPARK PLUG EUROPE GmbH nepřebírá žádnou zodpovědnost na případné nepřesnosti. Propojení jednotlivých produktů s vozidly nebo použitím s nářadím z této publikace se počítají za normálních podmínek užívání, nastavených odborníky pro vozidla registrovaná v Evropě. NGK SPARK PLUG EUROPE GmbH se nezavazuje k odpovědnosti za jiné užití nebo pro následné vybavení. Všechny objednaných výrobků se týkají platné podmínky a dohody dodávek NGK SPARK PLUG EUROPE GmbH.

Seznam křížových odkazů (strana 591-690) je dodán jako průvodce. Vzhledem k rozdílům v designu, materiálech atd. se produkty od různých výrobců nemusejí shodovat. Proto



se podívejte na naše doporučení ohledně řádného použití zakoupeného produktu.

Obrázky, diagramy a kresby v této publikaci nejsou závazné. Vlastnictví obrázků, diagramů, kreseb a dalších grafických prvků a dat jsou výhradním majetkem NGK SPARK PLUG EUROPE GmbH. Jakákoliv reprodukce této publikace, ať částečně nebo v celku je přísně zakázána bez písemné autorizace NGK SPARK PLUG EUROPE GmbH.

Specifikace se může změnit bez předchozího upozornění.

HU

Ez a katalógus hatályon kívül helyez minden korábbi katalógust. NGK SPARK PLUG EUROPE GmbH mindent megtett annak érdekében, hogy a katalógus összeállításakor rendelkezésre álló információkon alapuló pontos tájékoztatást biztosítson.

Ez a katalógus csak tájékoztató jellegű. NGK SPARK PLUG EUROPE GmbH nem vállal felelősséget az esetleges pontatlanságokért. A jelen katalógusban szereplő járműhöz kapcsolódó elemek, vagy alkalmazási eszközök használata szokásos alkalmazási feltételek mellett értendő, és azokat szakembernek kell az Európában bejegyzett járművekbe szerelnie. Minden ettől eltérő használatért, vagy utólagos beszerelésért az NGK SPARK PLUG EUROPE GmbH semmiféle felelősséget nem vállal. Valamennyi megrendelt termékre az NGK SPARK PLUG EUROPE GmbH által meghatározott feltételek vonatkoznak. A kiadványban szereplő ábrák, diagramok és rajzok nem szerződéses jellegűek.

A kereszthivatkozás lista (591-690 oldal) csak útmutatóként szolgál. A különböző gyártók által gyártott termékek tervezésében, az anyagaiban, stb. eltérések lehetnek. Ezért vegye figyelembe ajánlásainkat a megvásárolt termék a helyes használatához.

A kiadványban szereplő ábrák, diagramok, rajzok és egyéb grafikus elemek és adatok kizárólag az NGK SPARK PLUG EUROPE GmbH tulajdonát képezik. A kiadvány részleges vagy teljes reprodukciója kizárólag az NGK SPARK PLUG EUROPE GmbH előzetes és írásos engedélyezésével történhet.

A specifikáció előzetes értesítés nélkül megváltozhat.

RU

Данный каталог заменяет все ранее изданные каталоги. Компания NGK SPARK PLUG EUROPE GmbH предприняла все возможные усилия, чтобы обеспечить точность данных, подготовленных на основе доступной на момент составления каталога информации.

Данный каталог предназначен только для информационных целей. NGK SPARK PLUG EUROPE GmbH не несет ответственность за какие-либо неточности. Примеры установки продуктов в транспортные средства или использования инструментов в данном издании рассматриваются для случаев нормального режима эксплуатации, профессионального монтажа и транспортных средств, зарегистрированных в Европе. При любых других условиях ответственность за последствия использования оборудования NGK SPARK

PLUG EUROPE GmbH не несет. На все заказанные продукты распространяются действующие условия и положения NGK SPARK PLUG EUROPE GmbH. других производителей (стр. 591-690) предоставлен в качестве справочного материала. Продукты разных производителей могут не соответствовать друг другу вследствие отличий в конструкции, материалах и т. п. Просим вас руководствоваться нашими рекомендациями по надлежащему использованию приобретенного продукта.

Изображения, графики и рисунки в данном издании не являются договорными. Права на изображения, графики, рисунки и прочие графические элементы и данные принадлежат исключительно NGK Spark Plug Europe GmbH. Воспроизведение данного издания, частично или полностью, строго запрещается без предварительного письменного разрешения NGK Spark Plug Europe GmbH. Спецификация может быть изменена без предварительного уведомления.



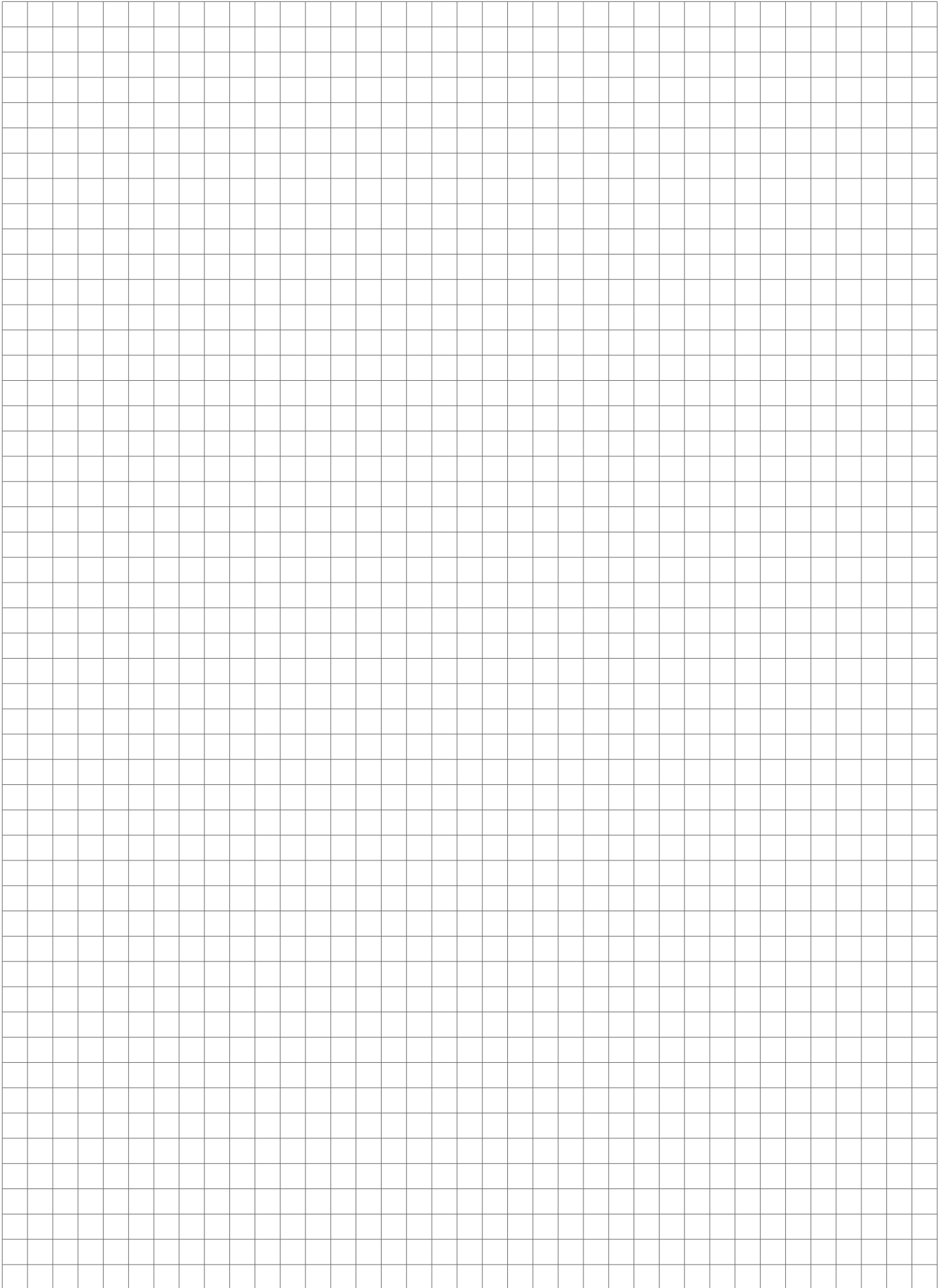

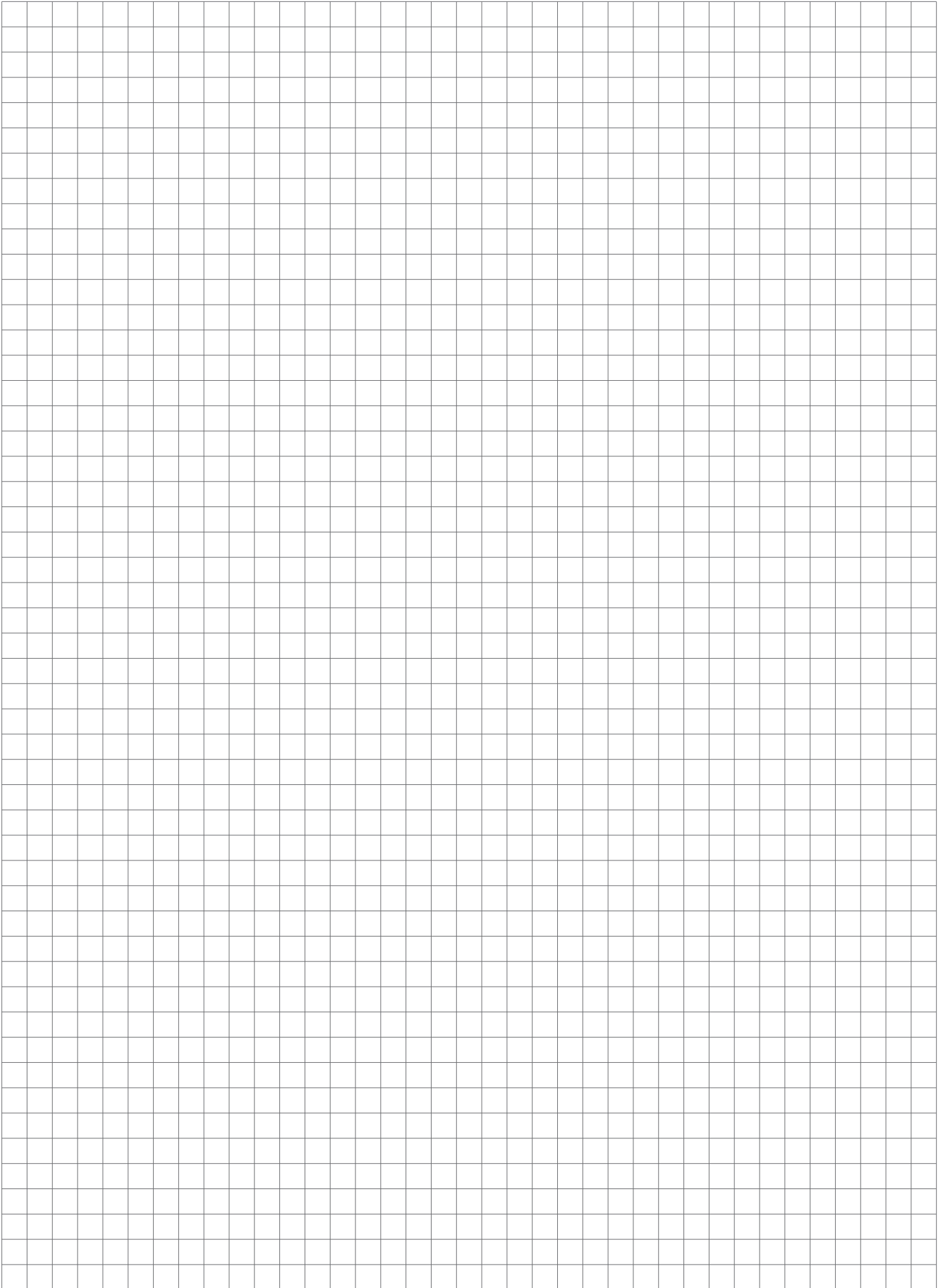



PRODUCT PORTFOLIO



IGNITION PARTS



VEHICLE ELECTRONICS

NGK SPARK PLUG offers a comprehensive range of products for the Aftermarket. Eight business areas (4-wheel, 2-wheel, industry, marine, gardening, agriculture, snowmobile and ATV/SSV) are supplied with more than 60,000 applications covering eight product lines.

With its two strong brands NGK and NTK and countless products to choose from, NGK SPARK PLUG is the world's largest supplier of spark plugs and oxygen sensors. While NGK Ignition Parts stands for the ultimate in performance – from spark plugs and glow plugs to ignition coils and ignition leads –, NTK Vehicle Electronics, the precision brand, offers vehicle electronics and great business opportunities.

All we do, innovate and produce, perfectly reflects our ultimate aim: Performance through Precision, Precision for Performance.



NGK – POWERED BY PERFORMANCE



Spark Plugs



Glow Plugs



Ignition Coils



Ignition Leads

NTK – POWERED BY PRECISION



Oxygen Sensors



Temperature Sensors



MAP/MAF Sensors



Engine Speed & Position Sensors

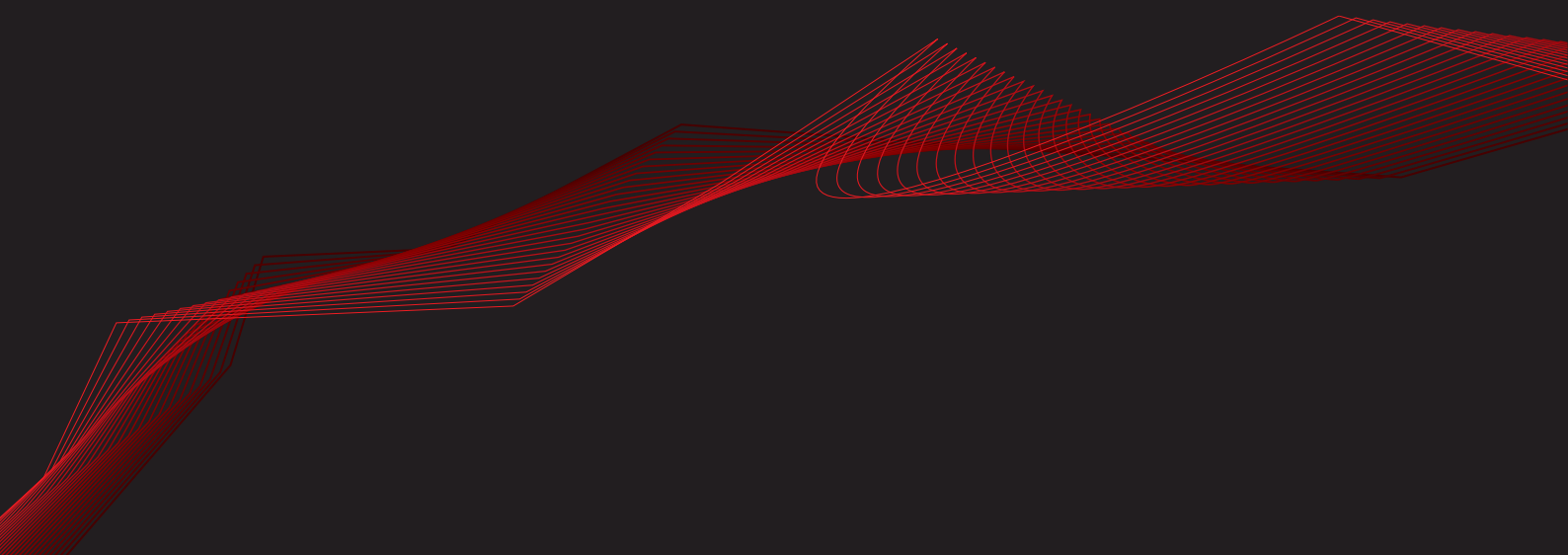

NGK SPARK PLUG EUROPE GmbH
Harkortstraße 41 • D-40880 Ratingen
Tel.: +49 (0) 2102 974-000 • Fax.: +49 (0) 2102 974-149



www.ngkntk.com

NGK | NTK
SPARK PLUGS | TECHNICAL CERAMICS
NGK SPARK PLUG CO., LTD.

EMEA // EUROPE-MIDDLE EAST-AFRICA